

(19) World Intellectual Property Organization
International Bureau



(43) International Publication Date
29 December 2011 (29.12.2011)

PCT

(10) International Publication Number
WO 2011/162788 A1

(51) International Patent Classification:
B67D 3/04 (2006.01) *B65D 47/28* (2006.01)

(21) International Application Number:
PCT/US2010/054973

(22) International Filing Date:
1 November 2010 (01.11.2010)

(25) Filing Language: English

(26) Publication Language: English

(30) Priority Data:
61/257,297 2 November 2009 (02.11.2009) US

(71) Applicant (for all designated States except US): **ILLINOIS TOOL WORKS INC.** [US/US]; 3600 West Lake Avenue, Glenview, Illinois 60026 (US).

(72) Inventors; and

(75) Inventors/Applicants (for US only): **HAUNER, David R.** [US/US]; c/o Illinois Tool Works Inc., 3600 West Lake Avenue, Glenview, Illinois 60026 (US). **WRIGLEY, Andrew N.** [NZ/US]; c/o Illinois Tool Works Inc., 3600 West Lake Avenue, Glenview, Illinois 60026 (US). **KOO, Yeong Heng** [SG/US]; c/o Illinois Tool Works Inc., 3600 West Lake Avenue, Glenview, Illinois 60026 (US).

(74) Agent: **HAUPTMAN, Benjamin J.**; 1700 Diagonal Road, Suite 300, Alexandria, Virginia 22314 (US).

(81) Designated States (unless otherwise indicated, for every kind of national protection available): AE, AG, AL, AM, AO, AT, AU, AZ, BA, BB, BG, BH, BR, BW, BY, BZ, CA, CH, CL, CN, CO, CR, CU, CZ, DE, DK, DM, DO, DZ, EC, EE, EG, ES, FI, GB, GD, GE, GH, GM, GT, HN, HR, HU, ID, IL, IN, IS, JP, KE, KG, KM, KN, KP, KR, KZ, LA, LC, LK, LR, LS, LT, LU, LY, MA, MD, ME, MG, MK, MN, MW, MX, MY, MZ, NA, NG, NI, NO, NZ, OM, PE, PG, PH, PL, PT, RO, RS, RU, SC, SD, SE, SG, SK, SL, SM, ST, SV, SY, TH, TJ, TM, TN, TR, TT, TZ, UA, UG, US, UZ, VC, VN, ZA, ZM, ZW.

(84) Designated States (unless otherwise indicated, for every kind of regional protection available): ARIPO (BW, GH, GM, KE, LR, LS, MW, MZ, NA, SD, SL, SZ, TZ, UG, ZM, ZW), Eurasian (AM, AZ, BY, KG, KZ, MD, RU, TJ, TM), European (AL, AT, BE, BG, CH, CY, CZ, DE, DK, EE, ES, FI, FR, GB, GR, HR, HU, IE, IS, IT, LT, LU, LV, MC, MK, MT, NL, NO, PL, PT, RO, RS, SE, SI, SK, SM, TR), OAPI (BF, BJ, CF, CG, CI, CM, GA, GN, GQ, GW, ML, MR, NE, SN, TD, TG).

Published:

— with international search report (Art. 21(3))

(54) Title: TAP ASSEMBLY

Figure 7

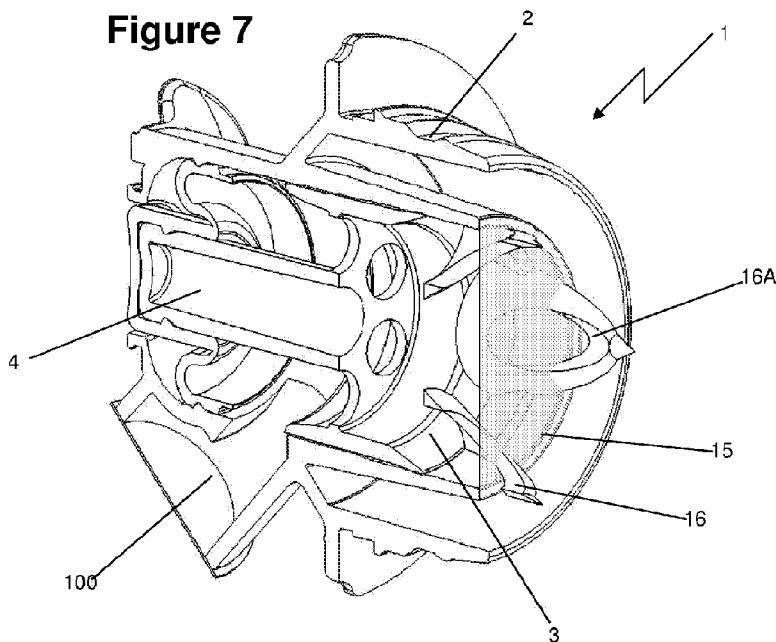

(57) Abstract: Tap assembly (1) configured to resist release of the tap when an internal vacuum is applied to the tap and to maintain aseptic conditions of fluid within an attached fluid container before first use of the tap. The tap assembly (1) having an actuation member (4A) configured to cover at least a portion of a bore (3) within a body (2); a cover configured to substantially enclose and abut a proximal portion of the actuation member (4A) to prevent actuation of the actuation member by engaging with the body; and a piercer element positioned on an end of the actuation member proximal to a sterility membrane (15) sealed over the bore and including at least one projection (16) to pierce the sterility membrane when the actuation member is actuated during first use of the tap assembly.

WO 2011/162788 A1

TAP ASSEMBLY**CROSS REFERENCES TO RELATED APPLICATIONS**

The present application is based on the provisional specification filed on November 2, 2009 in relation to US Patent Application NO. 61/257,297.

5 BACKGROUND TO THE INVENTION

A disadvantage with known fluid dispensing taps (such as that disclosed in WO2007054797) is release of the tap due to a pressure differential between the inside of the tap attached to a fluid container and the outside atmospheric pressure. Sterility of manufactured taps (for use in the storage and dispensing of
10 sterile fluids such as fruit juices) is obtained during the tap manufacture using processes such as steam autoclaving at temperatures above 100°C. Such treatment can frequently result in an internal vacuum being created. This can result in inadvertent actuation of the tap and unwanted and potentially hazardous spillage of fluid from the tap. One solution to this problem is to increase the force required
15 to release the tap by the user by increasing tolerances between a tap body and an actuation member of the tap or by biasing actuation of the tap. However this can be inconvenient or potentially hazardous to the user.

A further disadvantage with known taps is the risk of reaction of oxygen sensitive fluids, such as wine, with oxygen during transportation and/or storage of fluid within
20 the fluid container to which the tap is attached before use of the tap. Such reaction can spoil the fluid and reduce shelf-life.

One solution to this problem is purging of the tap and contents of the container to which the tap is attached with nitrogen to reduce the oxygen content of the stored

fluid to a level lower than normal air levels (approximately 21 %) to reduce the efficiency of aerobic microbial growth. However such treatment can be expensive.

It is an object of the present invention to address the foregoing problems or at least to provide the public with a useful choice.

- 5 It is acknowledged that the term 'comprise' may, under varying jurisdictions, be attributed with either an exclusive or an inclusive meaning. For the purpose of this specification, and unless otherwise noted, the term 'comprise' shall have an inclusive meaning - i.e. that it will be taken to mean an inclusion of not only the listed components it directly references, but also other non-specified components
- 10 or elements. This rationale will also be used when the term 'comprised' or 'comprising' is used in relation to one or more steps in a method or process.

Further aspects and advantages of the present invention will become apparent from the ensuing description which is given by way of example only.

SUMMARY OF THE INVENTION

- 15 According to one aspect of the present invention there is provided a tap assembly, comprising:

- a body having a bore formed therein;
- an actuation member configured to cover at least a portion of the bore;
- a cover configured to substantially enclose and abut a proximal portion of

20 the actuation member wherein the cover prevents actuation of the actuation member by engaging with at least one first engagement portion formed on the body;

- a sterility membrane sealingly positioned over an end of the bore; and

- a piercer configured to pierce the sterility membrane when the actuation member is actuated for the first time.

Preferably, the cover comprises a tamper evident indicator comprising a removable portion attached to the cover at at least one weakened join.

- 5 More preferably, the removable cover also comprises a pull-tab.

In this way the cover portion is configured to separate the removable portion of the cover from the body to expose the actuation member when a user breaks the at least one weakened join via the pull-tab.

Preferably, the actuation member comprises a button.

- 10 Preferably, the first engagement portion is a lip formed on the body which is configured to engage with a corresponding groove formed in the cover.

More preferably, the cover comprises a second engagement portion in the form of a groove formed in the actuation member which is configured to engage with a corresponding lip formed on the cover.

- 15 More preferably, the cover also comprises an annular band to sealingly engage with the body of the tap assembly after engagement of the annular bead with the engagement portion.

In this way the internal spaces between the cover and the actuation member and between the actuation member and the body are kept under aseptic conditions.

- 20 More preferably, the tap assembly also comprises at least one projection positioned on an end of the actuation member proximal to the sterility membrane.

In this way actuation of the actuation member causes the projection to pierce the sterility membrane to facilitate the flow of fluid between the fluid container and the

tap assembly.

Preferably, the at least one projection is 3 to 5 projections.

More preferably, one of the projections is positioned proximal of the other projections with respect to the sterility membrane.

- 5 In this way, the proximal projection provides an initial point of entry into the sterility membrane and minimises the force required to pierce the sterility membrane.

Preferably, the at least one projection comprises at least one fluid passageway to facilitate the flow of fluid between the bore and the tap assembly after entry of the at least one projection into the sterility membrane.

- 10 Preferably, the at least one projection comprises at least one serration configured to maintain the projection in place relative to the sterility membrane after entry of the projection into the sterility membrane.

Preferably, the at least one projection is configured to pull away the cut sterility membrane from the intended fluid flow path after withdrawal of the at least one

- 15 projection from the sterility membrane.

According to another aspect of the present invention there is provided a tap assembly, comprising:

- a body having a bore formed therein;
- an actuation member configured to cover at least a portion of the bore;
- 20 • a cover configured to substantially enclose and abut a proximal portion of the actuation member wherein the cover prevents actuation of the actuation member by engaging with at least one first engagement portion formed on the body and wherein the cover also comprises a tamper evident indicator

comprising a removable portion attached to the cover at at least one weakened joint;

- a sterility membrane sealingly positioned over an end of the bore; and
- a piercer configured to pierce the sterility membrane when the actuation member is actuated for the first time.

According to another aspect of the present invention there is provided tap assembly, comprising:

- a body having a bore formed therein;
- an actuation member configured to cover at least a portion of the bore;
- a cover configured to substantially enclose and abut a proximal portion of the actuation member wherein the cover prevents actuation of the actuation member by engaging with at least one first engagement portion formed on the body and wherein the cover also comprises a tamper evident indicator comprising a removable portion attached to the cover at at least one weakened joint;
- a sterility membrane sealingly positioned over an end of the bore; and
- a piercer configured to pierce the sterility membrane when the actuation member is actuated for the first time wherein the piercer comprises at least one projection positioned on an end of the actuation member proximal to the sterility membrane and wherein the at least one projection comprises at least one fluid passageway to facilitate a flow of fluid within the bore and from the tap assembly after entry of the at least one projection into the sterility membrane.

BRIEF DESCRIPTION OF DRAWINGS

Further aspects of the present invention will become apparent from the following description which is given by way of example only and with reference to the accompanying figures in which:

- 5 Figure 1 shows a perspective view of a preferred embodiment of the present invention in the form of a tap assembly;
- Figure 2 shows a side section view of the embodiment shown in Figure 1;
- Figures 3A-D show perspective views of the method of operation of the cover of the embodiment shown in Figure 1;
- 10 Figure 4 show a perspective view of the rear end of the embodiment shown in Figure 1 with projections held within the body of the tap;
- Figure 5 shows a sectional perspective view of the embodiment shown in Figure 4;
- 15 Figure 6 shows a perspective view of the rear end of the embodiment shown in Figure 4 with projections extending through a pierced sterility membrane;
- Figure 7 shows a sectional perspective view of the embodiment shown in Figure 6; and
- 20 Figure 8 shows a perspective view of a preferred embodiment of the projections shown in Figure 4.

DETAILED DESCRIPTION OF THE INVENTION

Referring to Figures 1 and 2, a preferred form of the invention in the form of a tap

assembly generally indicated by arrow 1. The tap assembly 1 comprises a body 2 having a bore 3 formed therein (best seen in Figure 2) for flowable material such as fluids to flow through the tap assembly 1 from a connected fluid container (not shown) and exit the body 2 at an outlet 100 (as shown in Figure 1). Typically the
5 body 2 is formed in a plastics material by injection moulding. The tap assembly 1 also comprises an actuation member in the form of button 4A on the end of a push rod 4 to control movement of the push rod 4 which is configured to cover the bore 3 and thereby control the flow of fluid through the outlet 100. The button 4A is connected to the body 2 at seal 5 (as shown in Figure 2) via a second engagement
10 portion in the form of annular groove 4B on button 4A engaging with corresponding annular bead 5A on seal 5. In this way aseptic conditions are maintained inside the tap assembly 1 during actuation of the button 4A.

A pair of wing-like projections 6 extends from the body 2 near the button 4A to provide convenient surfaces, transverse to the body, for an operator to grip with
15 their index and middle fingers while depressing the button 4A with their thumb.

The tap assembly 1 also comprises a cover in the form of a cap 7 which encloses and abuts the button 4A to prevent actuation of the button 4A. Cap 7 is fitted by clip-fit engagement with annular lip 8 on body 2. The cap 7 attaches to a first engagement portion in the form of lip 8 of the body 2 at groove 9 (best seen in
20 Figure 3D) which aseptically seals to the body 2 via a seal surface 10. In this way actuation of the button 4A is prevented by an internal pressure differential, such as a vacuum within the tap assembly 1. In addition the cap 7 connects to the upper periphery of the button 4A by clip-fit engagement of annular bead 11 with retainer groove 200 of cap 7 which retains the button-valve 4A with respect to the cap 7.

25 The cap 7 has a pull tab 12 to facilitate a user gripping the cap 7 (best seen in Figures 3A-D). In the preferred embodiment shown the pull-tab 12 comprising ring

12A connected to the cap 7 at lug 12B (as shown in Figures 3A to 3C). Indicative markings 12C on the pull-tab 12 indicate the need to remove the cap 7 before operation of the tap assembly 1. The pull tab 12 is connected to cap 7 via breakaway flap 13. The breakaway flap 13 is connected to the rest of the cap 7 by two weakened joins 14 extending substantially the profile of the cap 7 but ending proximal to the base 7A of the cap 7 (best seen in Figure 3A).

Figures 3A to C show the method of removal of the cap 7 from the body 2 of the tap assembly 1. In use a user 500 grips the ring 12A of the pull-tab 12 and pulls forward and away from the container (not shown) in the direction of arrow A (as shown in Figures 3A). The pull-tab 12 (and connected breakaway flap 13) is then pulled upward to tear the weakened joins 14 (as shown in Figure 3B). As the pull-tab 12 is pulled further upwards in the direction of arrow C the breakaway flap 13 continues to tear away from the remainder of the cap 7 at the weakened joins 14 (as shown in Figures 3C). The cap 7 then is pulled away from the body 3 of the tap assembly 1 in one piece which removes the breakaway flap 13 from part of the periphery of the cap 7 and allows the cap 7 to flex as required to remove bead 11 from groove 200 on button 4A. In this way the cap 7 provides a tamper evident feature to a user.

As shown in figures 4 to 7 the tap assembly 1 may also comprises a pierce-able sterility membrane 15 attached over the end of the bore 3. The sterility membrane 15 may be made of any suitable material which provides a barrier to the exchange of fluids between a fluid container (not shown) and the bore 3 (which improves the quality of oxygen sensitive fluids such as wine to improve the shelf life of the fluid during transport and storage and before use of the fluid container, such as a "bag-in-the box"), and is attached to the end of the bore 3 by any suitable process known to those skilled in the art, such as heat sealing. Such a sterility membrane 15 can also provide a further barrier to microorganisms.

If a sterility membrane is used, the push-rod 4 of the tap assembly 1 also incorporates three projections 16 positioned on an end of the push-rod 4 and proximal to the sterility membrane 15. Actuation of the push-rod 4 via the button 4A causes piercing of the sterility membrane 15 by the projections 16 and resultant
5 flow of fluid from the attached fluid container (not shown) once the projections 16 are withdrawn by release of the button 4.

Optionally one of the projections (16A in Figures 8 and 9) is positioned forward of the other projections 16 with the result that actuation of the push-rod 4 causes piercing of the sterility membrane 15 by the projection 16A first (as shown in figures
10 6 and 7). In this way, projection 16A provides an initial point of entry into the sterility membrane 15 and minimises the force required to pierce the sterility membrane 15 by the push-rod 4.

A person skilled in the art will appreciate that the shape of the projections 16 may be varied without departing from the scope of the present invention. Each
15 projection 16 comprises a shear wall 16A, a tapered surface 16B, a piercing point 16C and an aperture 16D (best seen in Figure 8). The combination of these features function as fluid entry ports 16E for fluid flow after the projections 16 have pierced the sterility membrane 15. This shape prevents occlusion of the side entry ports 16E by flaps of the sterility membrane 15 after piercing. In addition, the shape
20 of the projections is configured to pull away the cut sterility membrane 15 from the intended fluid flow path in the bore 3 in the event of withdrawal of the projections 16 from the pierced sterility membrane 15.

The base 17 may be connected to the push-rod 4 or may form an extension of the push-rod 4. Each projection can optionally include at least one serration (not
25 shown) configured to maintain the projections 16 in place relative to the sterility membrane 15 after entry of the projections 16 into the sterility membrane 15 which

aids in the cutting efficiency of the projections 16.

Thus preferred embodiments of the present invention have a number of advantages over the prior art which include:

- improved security of inadvertent release of the tap;
- 5 • improved storage of oxygen sensitive fluids;
- improved aseptic capability; and
- tamper proof indication.

Aspects of the present invention have been described by way of example only and it should be appreciated that modifications and additions may be made thereto
10 without departing from the scope thereof as defined in the appended claims.

What is claimed is:

1. A tap assembly, comprising:
 - a body having a bore formed therein;
 - an actuation member configured to cover at least a portion of the bore;
 - a cover configured to substantially enclose and abut a proximal portion of the actuation member wherein the cover prevents actuation of the actuation member by engaging with at least one first engagement portion formed on the body;
 - a sterility membrane sealingly positioned over an end of the bore; and
 - a piercer configured to pierce the sterility membrane when the actuation member is actuated for the first time.
2. A tap assembly as claimed in claim 1 wherein the cover comprises a tamper evident indicator comprising a removable portion attached to the cover at at least one weakened joint.
3. A tap assembly as claimed in claim 2 wherein the removable portion comprises a pull-tab.
4. A tap assembly as claimed in claim 1 wherein the actuation member comprises a button.
5. A tap assembly as claimed in claim 1 wherein the first engagement portion is a lip formed on the body which is configured to engage with a corresponding groove formed in the cover.
6. A tap assembly as claimed in claim 1 wherein the tap assembly comprises a

second engagement portion in the form of a groove formed in the actuation member which is configured to engage with a corresponding lip formed on the cover.

7. A tap assembly as claimed in claim 1 wherein the cover also comprises an annular bead to sealingly engage with the body of the tap assembly after engagement of the annular bead with the engagement portion.
8. A tap assembly as claimed in claim 1 wherein the piercer comprises at least one projection positioned on an end of the actuation member proximal to the sterility membrane.
9. A tap assembly as claimed in claim 8 wherein the at least one projection is 3 to 5 projections.
10. A tap assembly as claimed in claim 9 wherein one of the projections is positioned proximal of the other projections with respect to the sterility membrane.
11. A tap assembly as claimed in claim 8 wherein the at least one projection comprises at least one fluid passageway to facilitate the flow of fluid between the bore and the tap assembly after entry of the at least one projection into the sterility membrane.
12. A tap assembly as claimed in claim 8 wherein the at least one projection comprises at least one serration configured to maintain the projection in place relative to the sterility membrane after entry of the projection into the sterility membrane.
13. A tap assembly as claimed in claim 8 wherein the at least one projection is configured to pull away the cut sterility membrane from the intended fluid flow

path after withdrawal of the at least one projection from the sterility membrane.

14. A tap assembly, comprising:

- a body having a bore formed therein;
- an actuation member configured to cover at least a portion of the bore;
- a cover configured to substantially enclose and abut a proximal portion of the actuation member wherein the cover prevents actuation of the actuation member by engaging with at least one first engagement portion formed on the body and wherein the cover also comprises a tamper evident indicator comprising a removable portion attached to the cover at at least one weakened joint;
- a sterility membrane sealingly positioned over an end of the bore; and
- a piercer configured to pierce the sterility membrane when the actuation member is actuated for the first time.

15. A tap assembly, comprising:

- a body having a bore formed therein;
- an actuation member configured to cover at least a portion of the bore;
- a cover configured to substantially enclose and abut a proximal portion of the actuation member wherein the cover prevents actuation of the actuation member by engaging with at least one first engagement portion formed on the body and wherein the cover also comprises a tamper evident indicator comprising a removable portion attached to the cover at least one weakened joint;

- a sterility membrane sealingly positioned over an end of the bore; and
- a piercer configured to pierce the sterility membrane when the actuation member is actuated for the first time wherein the piercer comprises at least one projection positioned on an end of the actuation member proximal to the sterility membrane and wherein the at least one projection comprises at least one fluid passageway to facilitate a flow of fluid within the bore and from the tap assembly after entry of the at least one projection into the sterility membrane.

1/8

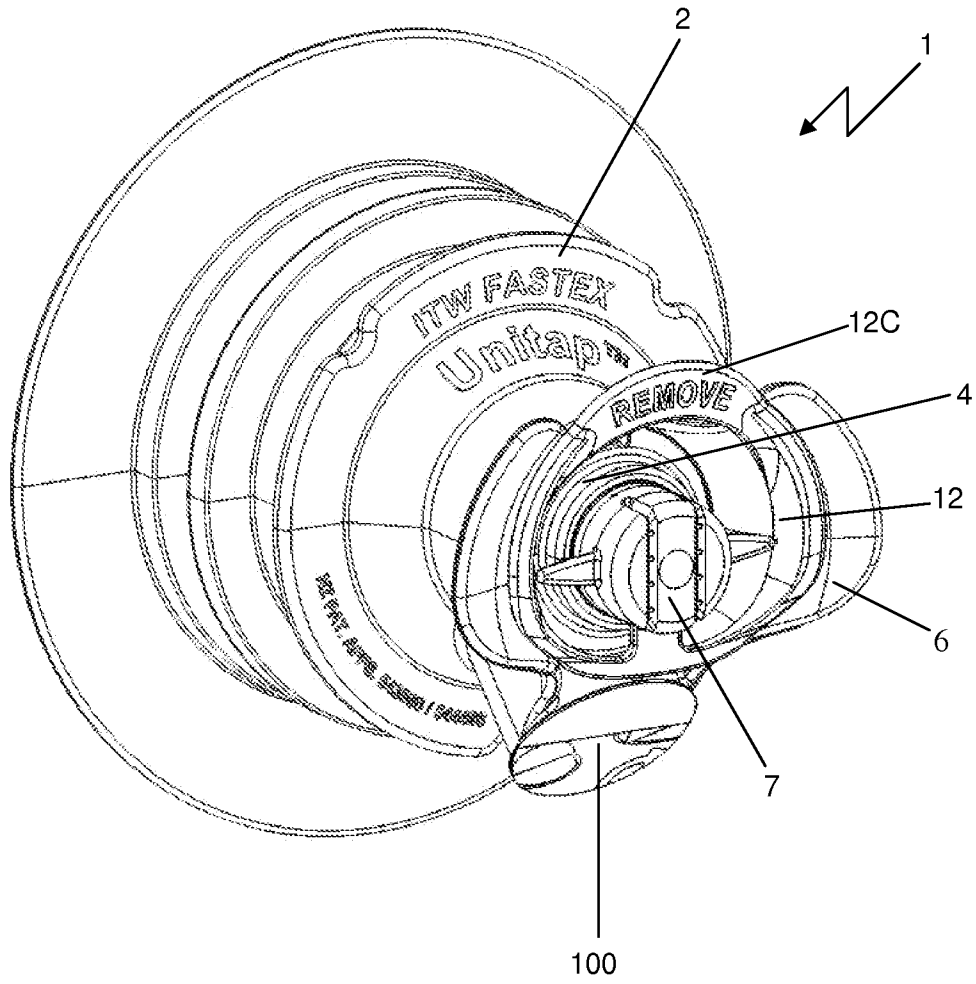

Figure 1

2/8

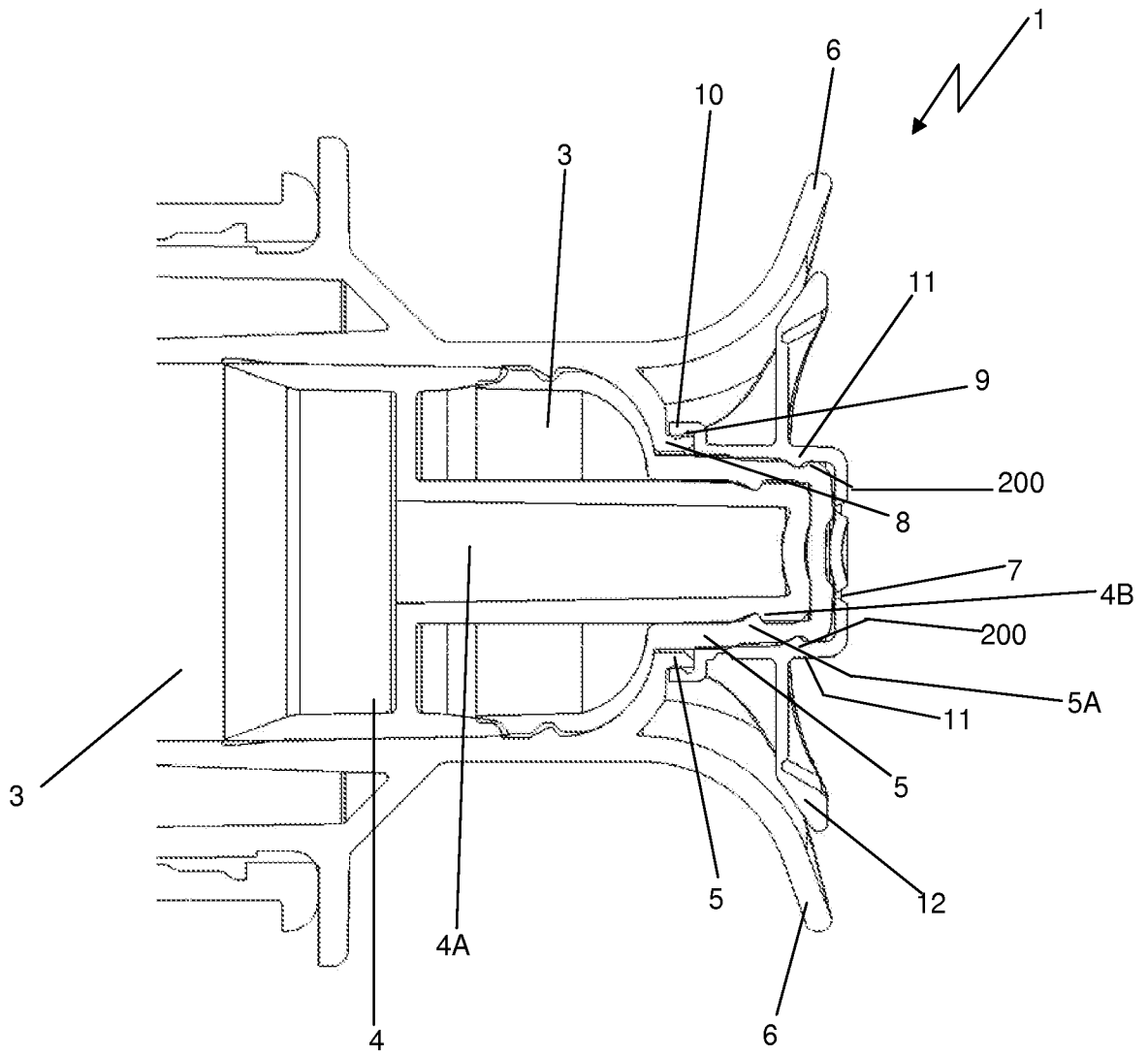
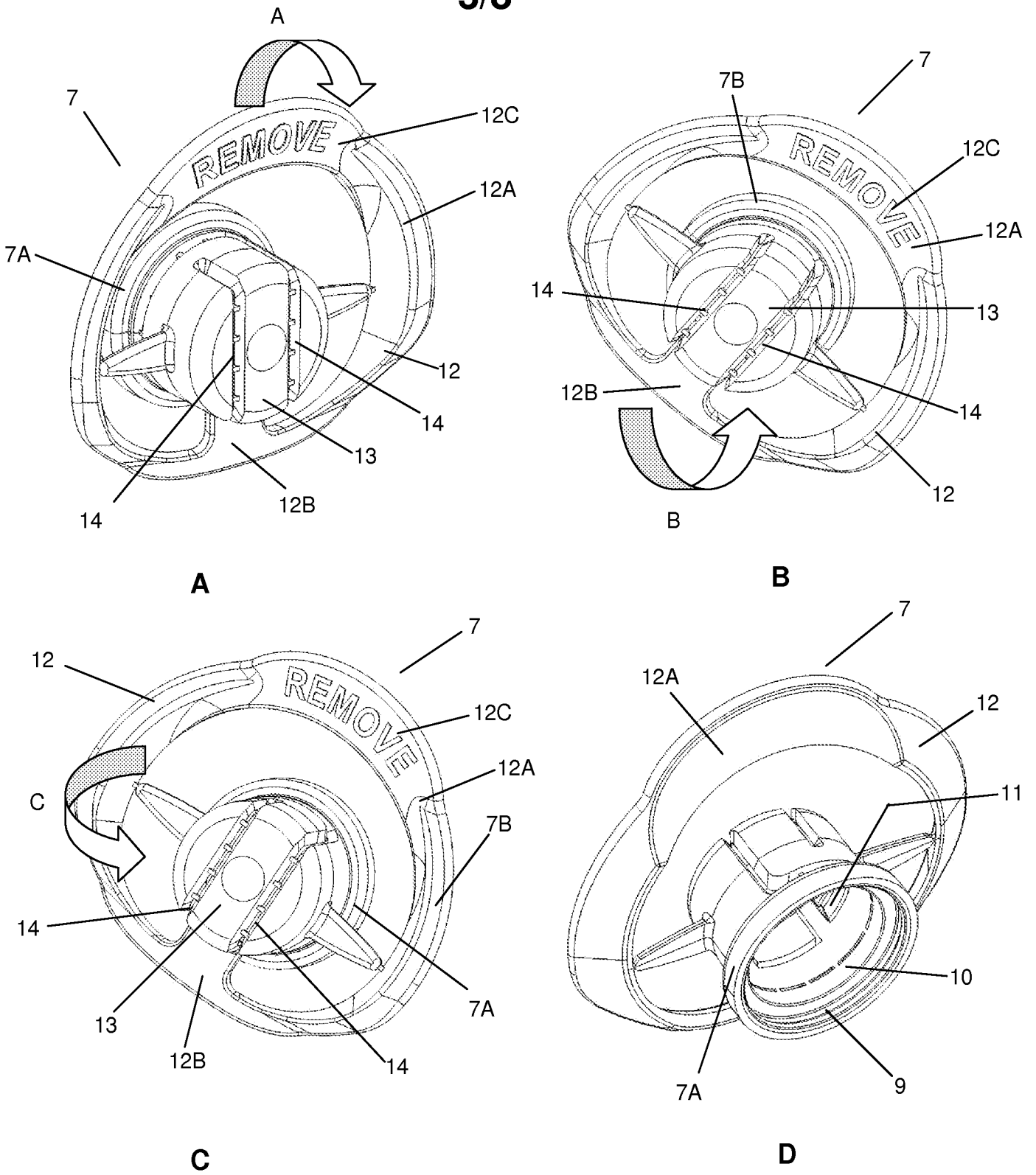

Figure 2

3/8



Figures 3A-D

4/8

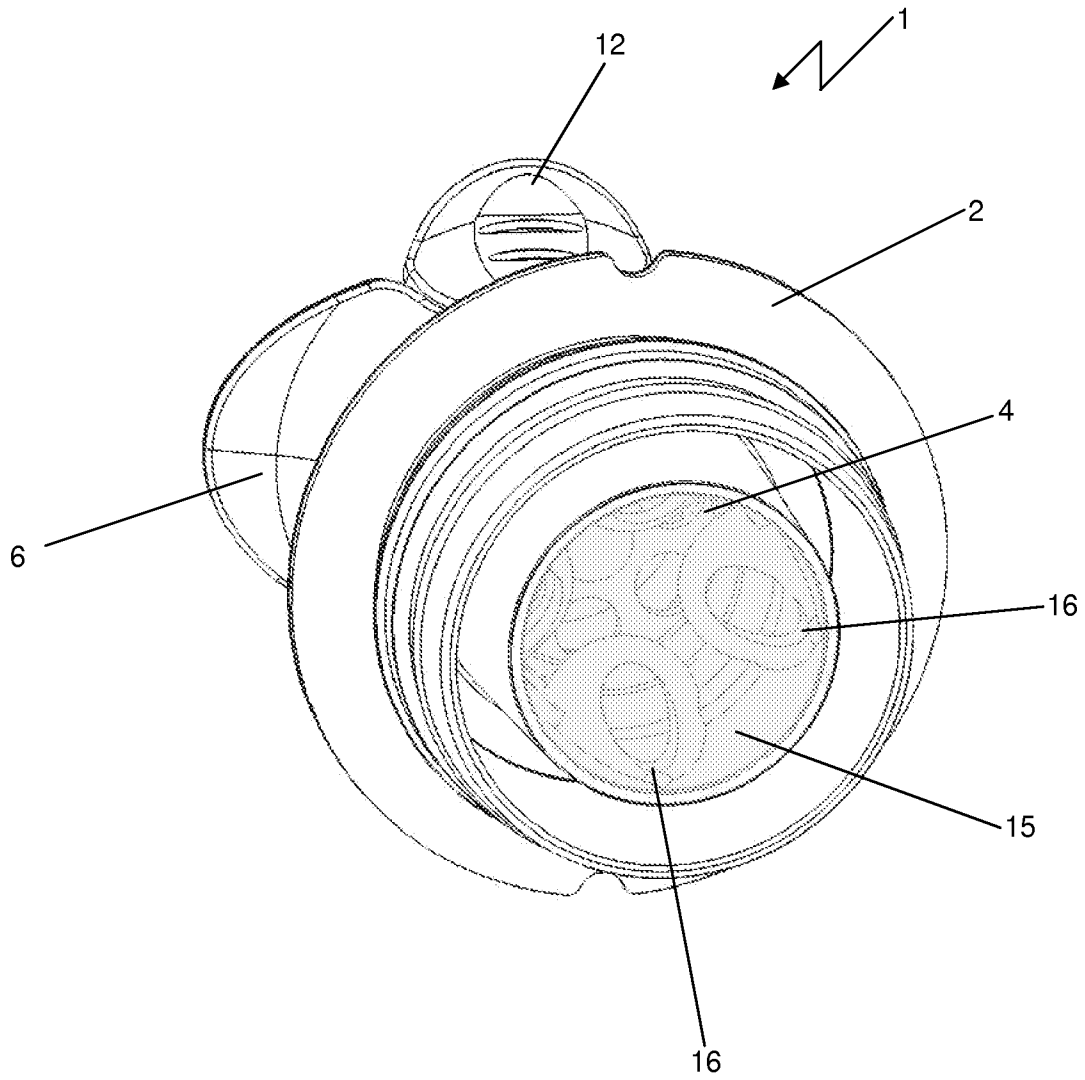

Figure 4

5/8

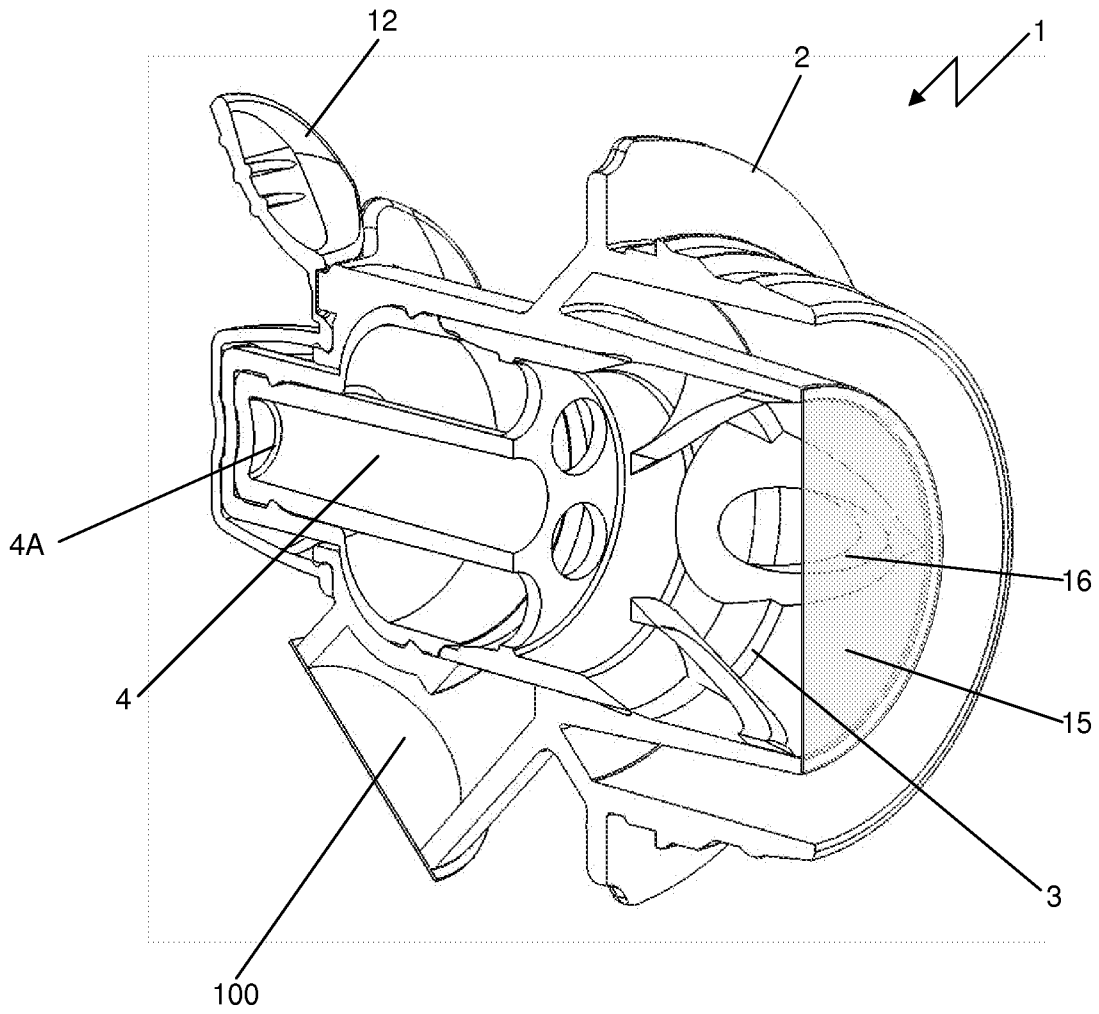

Figure 5

6/8

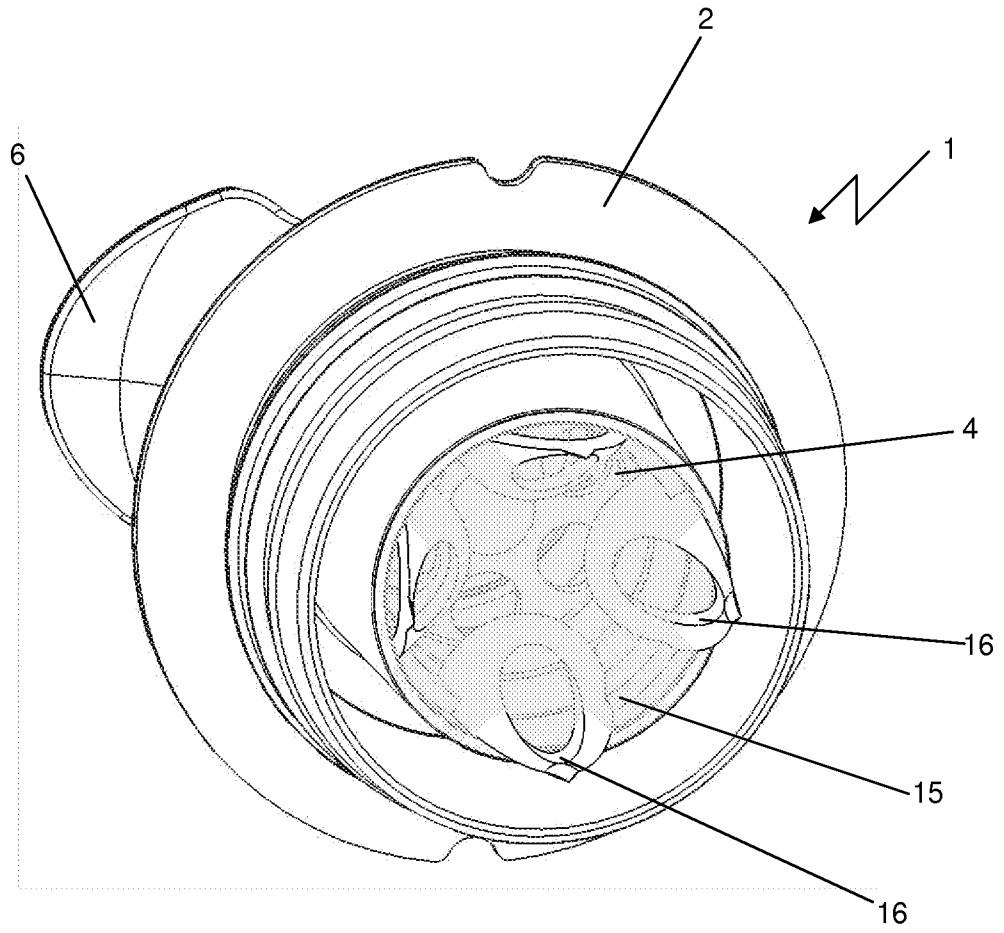

Figure 6

7/8

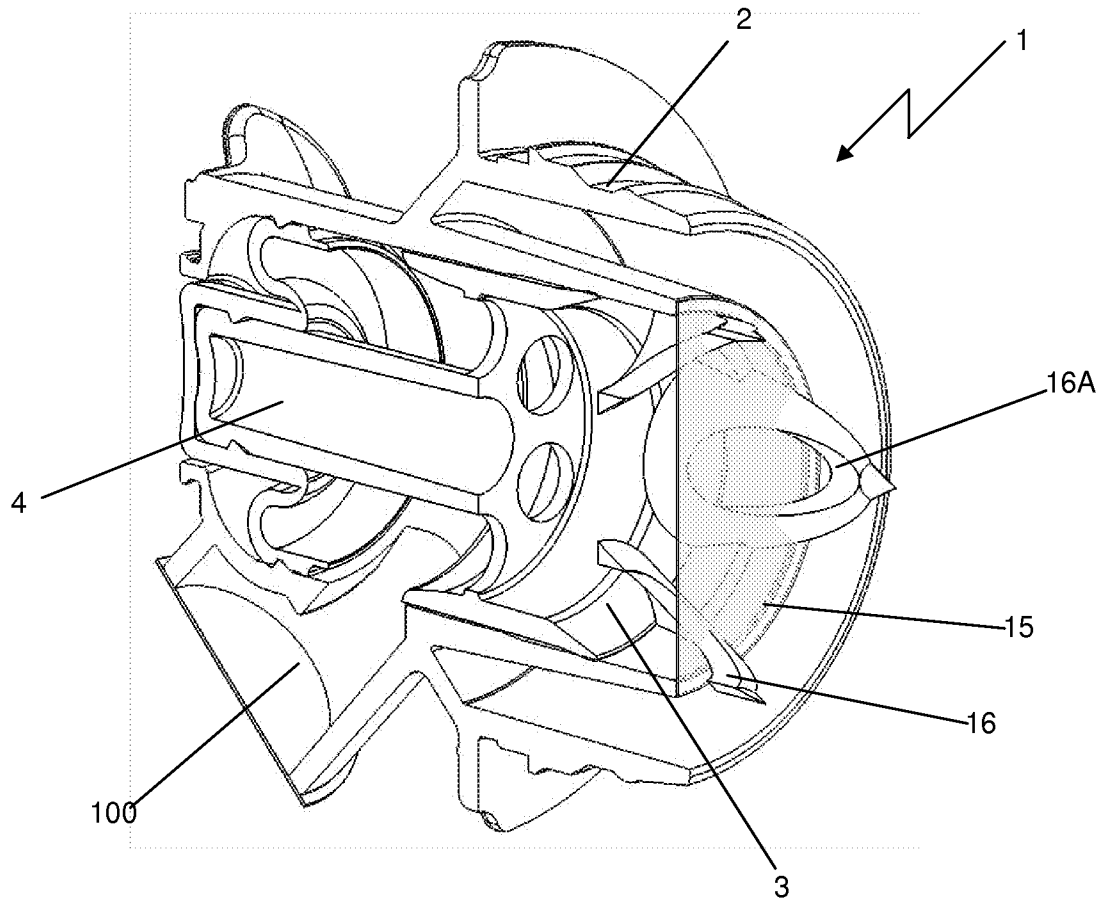

Figure 7

INTERNATIONAL SEARCH REPORT

International application No
PCT/US2010/054973

A. CLASSIFICATION OF SUBJECT MATTER
INV. B67D3/04 B65D47/28
ADD.
According to International Patent Classification (IPC) or to both national classification and IPC

B. FIELDS SEARCHED
Minimum documentation searched (classification system followed by classification symbols)
B65D B67D B67B

Documentation searched other than minimum documentation to the extent that such documents are included in the fields searched

Electronic data base consulted during the international search (name of data base and, where practical, search terms used)
EPO-Internal, WPI Data

C. DOCUMENTS CONSIDERED TO BE RELEVANT

Category*	Citation of document, with indication, where appropriate, of the relevant passages	Relevant to claim No.
Y	WO 2007/054797 A1 (ITW NEW ZEALAND LTD [NZ]; WRIGLEY ANDREW NICHOLSON [NZ]; KOO YEONG-HEN) 18 May 2007 (2007-05-18) cited in the application the whole document	1-15
Y	FR 2 619 612 A1 (DUFRENE ALAIN [FR]; NAAR RAYMOND [FR]; RAMONDOU BERNARD [FR]) 24 February 1989 (1989-02-24) the whole document	1-7,14, 15
Y	EP 0 148 971 A2 (DIEMOULDERS PTY LTD [AU]) 24 July 1985 (1985-07-24) * abstract; figures 3,5,6,8,10,11,14,15	8,11
	----- -/--	

Further documents are listed in the continuation of Box C.

See patent family annex.

* Special categories of cited documents :

<p>"A" document defining the general state of the art which is not considered to be of particular relevance</p> <p>"E" earlier document but published on or after the international filing date</p> <p>"L" document which may throw doubts on priority claim(s) or which is cited to establish the publication date of another citation or other special reason (as specified)</p> <p>"O" document referring to an oral disclosure, use, exhibition or other means</p> <p>"P" document published prior to the international filing date but later than the priority date claimed</p>	<p>"T" later document published after the international filing date or priority date and not in conflict with the application but cited to understand the principle or theory underlying the invention</p> <p>"X" document of particular relevance; the claimed invention cannot be considered novel or cannot be considered to involve an inventive step when the document is taken alone</p> <p>"Y" document of particular relevance; the claimed invention cannot be considered to involve an inventive step when the document is combined with one or more other such documents, such combination being obvious to a person skilled in the art.</p> <p>"&" document member of the same patent family</p>
--------------------------------------------------------------------------------------------------------------------------------------------------------------------------------------------------------------------------------------------------------------------------------------------------------------------------------------------------------------------------------------------------------------------------------------------------------------------------------------------------------------------------------------------------------------------------------------	------------------------------------------------------------------------------------------------------------------------------------------------------------------------------------------------------------------------------------------------------------------------------------------------------------------------------------------------------------------------------------------------------------------------------------------------------------------------------------------------------------------------------------------------------------------------------------------------------------------------------------------------------------------------------------------------------------------

Date of the actual completion of the international search 19 January 2011	Date of mailing of the international search report 02/02/2011
----------------------------------------------------------------------------------	----------------------------------------------------------------------

Name and mailing address of the ISA/ European Patent Office, P.B. 5818 Patentlaan 2 NL - 2280 HV Rijswijk Tel. (+31-70) 340-2040, Fax: (+31-70) 340-3016	Authorized officer Ferrien, Yann
----------------------------------------------------------------------------------------------------------------------------------------------------------------------	-----------------------------------------

INTERNATIONAL SEARCH REPORT

International application No
PCT/US2010/054973

C(Continuation). DOCUMENTS CONSIDERED TO BE RELEVANT

Category*	Citation of document, with indication, where appropriate, of the relevant passages	Relevant to claim No.
Y	EP 0 304 972 A1 (LYNES HOLDING SA [LU]) 1 March 1989 (1989-03-01) * abstract; figures 2-3 column 3, line 22 - line 33 -----	9,10,12, 13
A	EP 0 043 698 A1 (WRIGHTCEL LTD [AU]) 13 January 1982 (1982-01-13) * abstract; figures 1-3 -----	8,10
A	GB 2 082 152 A (A C I OPERATIONS) 3 March 1982 (1982-03-03) * abstract; figures 4-11 -----	8,13

INTERNATIONAL SEARCH REPORT

Information on patent family members

International application No
PCT/US2010/054973

Patent document cited in search report	Publication date	Publication date	Patent family member(s)	Patent family member(s)	Publication date
WO 2007054797	A1	18-05-2007	AT	454325 T	15-01-2010
			AU	2006313505 A1	18-05-2007
			EP	1951592 A1	06-08-2008
			ES	2339163 T3	17-05-2010
			JP	2009523100 T	18-06-2009
			US	2008283790 A1	20-11-2008
			-----	-----	-----
FR 2619612	A1	24-02-1989	NONE		
EP 0148971	A2	24-07-1985	AR	227075 A1	15-09-1982
			BR	8107952 A	22-06-1982
			CA	1158615 A1	13-12-1983
			DE	3173915 D1	03-04-1986
			DK	533381 A	05-06-1982
			EP	0053891 A1	16-06-1982
			ES	270895 U	16-12-1983
			FI	813848 A	05-06-1982
			NO	814133 A	07-06-1982
			NZ	199161 A	30-08-1985
			PT	74084 A	01-01-1982
			SE	8107222 A	05-06-1982
			SE	8604729 A	05-11-1986
			US	4469249 A	04-09-1984
			US	4624392 A	25-11-1986
-----	-----	-----	-----	-----	
EP 0304972	A1	01-03-1989	BE	1000760 A6	28-03-1989
			CA	1299142 C	21-04-1992
			DE	3863720 D1	22-08-1991
			GR	3002574 T3	25-01-1993
			JP	1045266 A	17-02-1989
			JP	2648499 B2	27-08-1997
			US	4884705 A	05-12-1989
-----	-----	-----	-----	-----	
EP 0043698	A1	13-01-1982	DE	3166460 D1	08-11-1984
-----	-----	-----	-----	-----	
GB 2082152	A	03-03-1982	DE	3124373 A1	15-07-1982
			ES	8203298 A1	01-07-1982
			FR	2490613 A1	26-03-1982
			IT	1168134 B	20-05-1987
-----	-----	-----	-----	-----	