

(19) World Intellectual Property  
Organization  
International Bureau



(43) International Publication Date  
22 December 2005 (22.12.2005)

PCT

(10) International Publication Number  
**WO 2005/120981 A2**

- (51) International Patent Classification<sup>7</sup>: **B65D 75/58** (74) Agent: FANZINI, Valeriano; c/o Bugnion S.p.A., Via Goito, 18, I-40126 Bologna (IT).
- (21) International Application Number: PCT/IB2005/051908 (81) Designated States (unless otherwise indicated, for every kind of national protection available): AE, AG, AL, AM, AT, AU, AZ, BA, BB, BG, BR, BW, BY, BZ, CA, CH, CN, CO, CR, CU, CZ, DE, DK, DM, DZ, EC, EE, EG, ES, FI, GB, GD, GE, GH, GM, HR, HU, ID, IL, IN, IS, JP, KE, KG, KM, KP, KR, KZ, LC, LK, LR, LS, LT, LU, LV, MA, MD, MG, MK, MN, MW, MX, MZ, NA, NG, NI, NO, NZ, OM, PG, PH, PL, PT, RO, RU, SC, SD, SE, SG, SK, SL, SM, SY, TJ, TM, TN, TR, TT, TZ, UA, UG, US, UZ, VC, VN, YU, ZA, ZM, ZW.
- (22) International Filing Date: 9 June 2005 (09.06.2005)
- (25) Filing Language: Italian
- (26) Publication Language: English
- (30) Priority Data: MI2004A001170 10 June 2004 (10.06.2004) IT
- (71) Applicant (for all designated States except US): **BORDI CARLO S.R.L.** [IT/IT]; Via Ungaretti Giuseppe, 3, I-29012 Caorso (IT).
- (72) Inventor; and
- (75) Inventor/Applicant (for US only): **PERDONI, Nora** [IT/IT]; Via Trebbiola, 27, I-29100 Piacenza (IT).
- (84) Designated States (unless otherwise indicated, for every kind of regional protection available): ARIPO (BW, GH, GM, KE, LS, MW, MZ, NA, SD, SL, SZ, TZ, UG, ZM, ZW), Eurasian (AM, AZ, BY, KG, KZ, MD, RU, TJ, TM), European (AT, BE, BG, CH, CY, CZ, DE, DK, EE, ES, FI, FR, GB, GR, HU, IE, IS, IT, LT, LU, MC, NL, PL, PT, RO,

[Continued on next page]

(54) Title: IMPROVED BAG

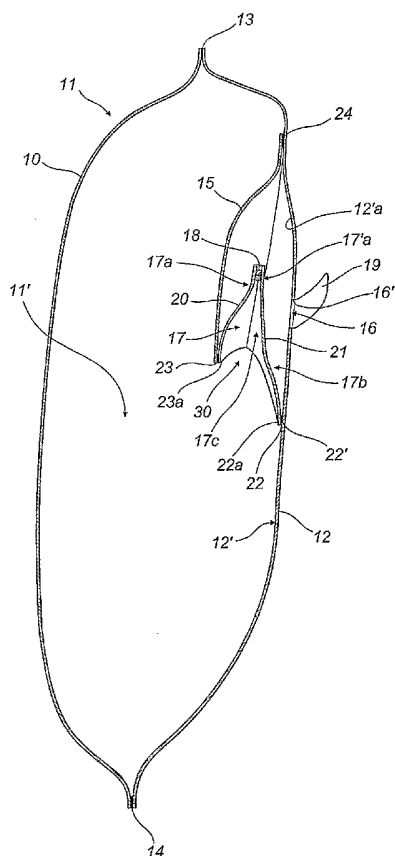

(57) Abstract: A reclosable bag has walls made from plastic film and is provided with a facilitated opening area that forms an outlet opening (16) from which a front end of a tubular element (17) can be pulled out; said front end forming a spout that can be closed with a zip. The back of the tubular element (17) is connected to the wall that is provided with the facilitated opening area and surrounds the outlet opening (16) so that the bag can be closed again using the zip to seal it after the facilitated opening area has been opened.

WO 2005/120981 A2



SE, SI, SK, TR), OAPI (BF, BJ, CF, CG, CI, CM, GA, GN, GQ, GW, ML, MR, NE, SN, TD, TG).

*For two-letter codes and other abbreviations, refer to the "Guidance Notes on Codes and Abbreviations" appearing at the beginning of each regular issue of the PCT Gazette.*

**Published:**

— *without international search report and to be republished upon receipt of that report*

IMPROVED BAGDescription5 Technical Field

The present invention relates to a bag for containing a product.

The bag is made preferably from at least one sheet of plastic film and is particularly suitable for containing a food  
10 product such as, for example, food, in granular or similar form) for dogs or other pets.

Background Arts

Bags of the kind with a product outlet opening made in one  
15 wall of the bag have been known for some time in the packaging trade. With these prior art bags, it is difficult to control the flow of the product as it is poured out of the bag, with the result that the product comes out haphazardly and is often spilt outside the container or area it was supposed to be poured into.  
20 To avoid this problem, users of bags of this kind tend to hold the bag unnaturally close to the container they want to pour the product into, and without always managing to avoid spilling the product. Indeed, holding the bag too close in this way hides the target container or area from view, with the result that either  
25 too much product is poured out or too little, making it necessary, in the latter case, to repeat the operation several times.

Bags that can be re-closed (typically made of plastic) are also known. These enable the product to be stored inside the bag after opening when the contents of the bag are not used up all at  
30 once. This problem is felt particularly strongly in the food packaging industry because food products go bad very quickly when they are exposed to the atmosphere and will keep much longer if the bags that contain them are well sealed.

To meet these packaging demands, prior art proposes bags of  
35 various kinds with a first opening area and a zip that enables the bag to be re-closed after it has been opened for the first time. In one prior art bag of this kind, the first opening area consists of a weakened portion in the respective plastic wall of the bag

which is designed to be torn when the bag is opened for the first time. The zip is usually sealed to the inside faces of the bag walls. The zip typically consists of two interlocking strips of plastic that enable the bag to be hermetically sealed again after  
5 it has been opened. For this purpose, the two strips of the zip are applied to two opposite inside faces of the bag in such a way that the bag can be re-closed after it has been opened for the first time. Bags of this kind are relatively complicated to make.

Applying the strips to two opposite inside faces of the bag  
10 walls unduly complicates the bag forming process and increases production costs. The strips must be applied in such a way that they are properly aligned after the bag is formed. To do this, the zip must be applied during the bag forming process making the packaging process extremely complicated and requiring the use of  
15 sophisticated, high-cost forming machines.

To overcome these problems, zips consisting of two parts that can be applied simultaneously to the same bag wall have been proposed. Each of the two parts of the zip has a strip that projects laterally from the zip closing area. More specifically,  
20 the two strips project from the zip closing line in opposite directions, thus forming two portions on the same bag wall designed to be joined to each other. The bag wall along the zip closing line has a weakened portion that can be torn more easily when the bag is opened to form an outlet through which the product  
25 can be taken out of the bag.

Thus, the two parts of the zip can be applied to the plastic film before the film is fed to the bag forming machine. This considerably simplifies the bag forming process and makes it possible to use less sophisticated packaging machinery.

30 These bags, however, are not free of disadvantages either.

In particular, the outlet created when the bag is opened for the first time opens in a plane that is substantially perpendicular to the plane that contains the bag wall precisely because of the way the strips forming the zip are applied to the  
35 bag wall above and below the outlet opening. This makes it awkward to pour the product out of the bag because the bag wall tends to return to the flat state. In addition, the weight of the product

(for example, in granular form) acting on the inside wall of the bag, both above and below the outlet opening, tends to close the outlet, thus obstructing the opening and making it more difficult for the product to come out of the bag. Moreover, zip closures of this kind cannot guarantee an effective durable seal once the bag has been opened. The zip is applied directly to the bag wall at two different heights. It is therefore quite easy to accidentally open the bag by mistakenly knocking the bag wall against something in the vicinity of the zip. A bag accidentally opened in this way might even go unnoticed for a relatively long period of time, thus allowing the quality of the product it contains (for example a food product) to deteriorate. Furthermore, the single bag wall to which the zip is applied in prior art bags of this kind is wider than the zip closure itself and it is therefore difficult to impart a desired direction to the product being poured out of it, thus creating the same problems as those described above.

#### Summary of the Invention

It has been provided a bag for containing a product, in particular a food product, preferably in granular form; the bag having a body, made preferably from at least one sheet of plastic film, defining an internal space for holding the product and having an outlet opening through which the product comes out; the bag being characterised in that it comprises means for channelling the product out of it.

This minimises unwanted spilling of the product, making it much easier to control the flow of the product as it is being poured out of the bag by the user.

#### Brief Description of the Drawings

The technical characteristics and advantageous aspects of the invention are apparent from the detailed description which follows, with reference to the accompanying drawings, which illustrate a preferred embodiment of the invention provided merely by way of example without restricting the scope of the inventive concept, and in which:

- Figure 1 is a lateral cross section of a bag made in

accordance with the present invention;

- Figure 2 is a cross section of a part of the bag illustrated in Figure 1;

5 - Figure 3 is a front view of a bag according to the present invention in the open condition;

- Figure 4 shows the inside wall of the bag illustrated in the drawings listed above;

- Figure 5 is a detail view showing the tubular element in a bag according to the invention;

10 - Figure 6 is a front view of a second embodiment of the tubular element in the bag according to the invention, the wall to which the tubular element is connected being drawn with a dashed line;

15 - Figure 7 is a front perspective view of the second preferred embodiment of the tubular element in the bag according to the invention, in the open condition;

- Figure 8 is a detail view, similar to that Figure 5, of a third embodiment of the tubular element in the bag according to the invention;

20 - Figure 9 is a front perspective view of a fourth preferred embodiment of the tubular element in the bag according to the invention, in the open condition;

25 - Figure 10 is a longitudinal cross section of the fourth preferred embodiment of the tubular element in the bag according to the invention;

- Figure 11 is a longitudinal cross section of a fifth preferred embodiment of the tubular element in the bag according to the invention;

30 - Figure 12 is an exploded perspective view of a sixth preferred embodiment of the tubular element in the bag according to the invention;

35 - Figure 13 is a perspective assembly view of the sixth preferred embodiment of the tubular element in the bag according to the invention, the wall to which the tubular element is connected being drawn with a dashed line;

- Figure 14 is a front perspective view of the sixth preferred embodiment of the tubular element in the bag according

to the invention, in the extracted condition.

Description of the Preferred Embodiments of the Invention

5           Figures 1 to 5 illustrate a first preferred embodiment 11 of  
the bag according to the invention. The bag 11 is made from a  
sheet of plastic film and might be used to hold a food product,  
such as a product in granular form. In particular, the bag 11  
might contain a food product for pets. The bag might contain up to  
several kilograms of product which is usually not used up all at  
10           once when the bag is opened for the first time. It is therefore  
very useful for the bag to be made in such a way that it can be  
re-closed after opening so that the product it contains can be  
kept as long as possible if it is not all used up when the bag is  
opened.

15           The bag 11 is closed in customary manner at the top by a  
transversal seal 13 and at the bottom by a transversal seal 14.  
The bag, if made from a folded web of plastic film, may also  
comprise a lateral seal, not shown in the drawings, and, being of  
customary type, not relevant to this invention. The bag, for  
20           example, might be made by a vertical form/fill/seal machine of  
well-known type used to form generic bags, including bags that  
cannot be re-closed.

          As may be inferred in particular from Figure 1, which  
schematically illustrates a full bag, the bag according to the  
25           invention comprises a front wall 12, a rear wall 10 and, in  
certain cases, side walls, which may be concertina shaped,  
together defining an internal space 11' for holding the product.  
The product is not illustrated in the accompanying drawings.

          The wall 12 of the bag 11 has a facilitated opening area 19  
30           that allows the formation of an outlet opening 16 through which  
the product can be poured out. As may be inferred from the  
drawings, the facilitated opening area consists of a tear tab 19  
made of film and attached to the front wall 12 of the bag at a  
weakened film portion made according to known processes.  
35           Initially, the tab 19 closes the bag wall 12 and, when the bag is  
opened for the first time, is torn away to form an elongated  
opening 16 in the wall 12. Figure 1 shows the bag in the half open

condition, while the tab 19 is being torn in order to make the opening 16.

The facilitated opening area might also consist of a plain line of weakened film that can be torn open by pulling a string that is suitably positioned in the bag according to known processes.

As illustrated in particular in Figure 3, the opening 16 is made in a central area of the respective wall 12 and is shorter in length than the bag wall 12 is wide.

Means 17 are advantageously provided to channel the product out of the bag.

As illustrated, the means for channelling the product out of the bag are advantageously embodied by a tubular element 17 which comprises a spout 17' through which the product can be poured out of the bag and which is situated at the front end portion 17a of the tubular element 17 and an inlet 30 by which the product can be directed into the channelling means and which is located at the opposite, rear end 17b of the tubular element.

This tubular element 17 may be advantageously used to dispense the product (for example, dog food in granular form) from the bag.

Advantageously, the front end portion 17a of the channelling means extends to the product outlet opening 16 and preferably, as illustrated, passes through the opening 16.

Thus, a channelling portion is formed which extends in a direction substantially perpendicular to the front wall 12 and which enables the direction of product flow to be more easily controlled as the product is poured out of the bag into a desired area.

More specifically, the front end portion 17a of the means 17 for channelling the product out of the bag can be pulled out through the opening 16.

As illustrated, the means 17 for channelling the product out of the bag extend into the bag by a certain length, remaining close to the front wall 12, with the rear end 17b of the channelling means being positioned well below the opening 16.

Thus, the product to be poured out of the bag advantageously

starts being guided while it is still inside the bag.

The tubular element 17 thus forms a channel 17" which places the inside of the bag in communication with the outside.

5 More specifically, the first section 17b of the channel extends upwardly so that the product is channelled in a direction substantially parallel to the respective wall 12, at least for the first rear section, thereby applying a particularly advantageous guiding and retaining action on the product. Thus, there is less risk of the product falling out of the bag accidentally when the  
10 bag is tipped over to start pouring.

During use, the channel also has a second, perpendicular or transversal section 17a positioned at an angle to the first section 17b.

15 The channelling means comprise closing means that can be opened and re-closed.

In this regard, the front end of the tubular element 17 forms a spout 17' that can be closed with a zip 18. The spout, as well illustrated Figure 3, protrudes from the outlet opening (or slot) 16 made in the bag wall 12 to allow the product to be poured  
20 out. The zip 18 is located on the inside walls of the spout and is made according to known processes. It might, for example, comprise a rib protruding from a wall 20 of the spout and designed to engage with a groove consisting of two parallel ribs protruding from an opposite wall 21 of the spout.

25 As shown in the drawings, the part of the channelling means with the zip 18 is straight and is just a little shorter than the slot 16 made in the wall 12. This makes it easier to pull the front end of the tubular element out of the bag while using the full length of the slot 16 to pour out the product.

30 As illustrated, one part 22a of the edge of the inlet 30 to the channelling means 17 extends further towards the bottom of the bag than the other part 23a of the edge of the inlet 30.

The part 22a of the edge that extends further towards the bottom of the bag is the part of the edge that is closer to the  
35 bag wall 12.

This forms a protruding channel portion 21a on which the product can advantageously rest and can more easily enter the

channelling means.

As illustrated, the entire edge 22a, 23a of the inlet 30 to the channelling means extends below the bag opening 16.

5 As shown in the drawings, the inlet 30 to the channelling means is wider than the outlet of the spout 17' but less wide than the respective bag wall 12.

10 The lateral edges 17c, 17d of the channelling means converge towards the front of the channelling means themselves. This creates a "funnel" effect which guides the product towards a central part of the bag and from there the product is channelled out of the bag.

Means are also provided for attaching the channelling means 17 to the bag.

15 In a particularly advantageous manner, the means for attaching the channelling means 17 to the respective bag wall run all the way around the outlet opening 16 so that the product can come out of the bag only through the channelling means.

20 More specifically, the means for attaching the channelling means 17 to the respective bag wall comprise a respective surface 22 forming part of the channelling means 17 and facing the inside surface 12' of the respective wall 12 it is joined to.

The surface 22 by which the channelling means 17 are attached to the wall 12 under the outlet opening 16 of the bag is defined by a portion 22 at the rear edge of the channelling means.

25 As shown in the drawings, the means for attaching the channelling means 17 to the respective bag wall comprise a second surface 23 forming part of the channelling means 17 and being defined by a portion 23 at the rear edge of the channelling means themselves.

30 The second surface 23 for attaching the channelling means 17 extends below the opening 16 but above the first attachment surface 22.

35 In another preferred embodiment not illustrated in the accompanying drawings, the second surface 23 for attaching the channelling means 17 might be joined to the inside surface of the opposite wall 10 either directly or by means of a patch or other additional element.

Advantageously, the second surface 23 for attaching the channelling means 17 is joined to a respective joining patch 15.

As illustrated, the joining patch 15 is connected to the inside surface of the bag wall 12 above, on one side of and below  
5 the opening 16.

In fact, the joining patch 15 has a boundary 24 with an upper edge 24a, opposite lateral edges 24b, 24c and a lower edge comprising lateral sections 24d, 24e for attachment to the bag, whilst a middle section 24' of the lower edge attaches the edge 23  
10 of the channelling means which faces the inside of the bag.

As illustrated, the patch surrounds the opening 16 and is quadrangular.

In short, the back of the tubular element 17 communicates with the inside of the bag 11 through an inlet 30 whose edge is sealed along a first section 22 to the inside face 12' of the bag  
15 wall 12. The edge of the inlet 30 is also sealed to the bag face on the other side of the slot 16, advantageously by means of the film patch 15 to which a second section 23 of the tubular element is sealed. The section 23 describes a closed path in conjunction  
20 with the first section 22 by which the tubular element 17 is joined to the bag wall 12 (see Figure 5).

In other terms, the patch 15 is located inside the bag 11 and forms a chamber that houses the tubular element 17 in such manner that the channel formed by the tubular element 17 is the  
25 only way of accessing the inside of the bag after the tab 19 has been removed. For this purpose, the patch 15 is attached to the inside wall of the bag by a seal 24 which, in turn, forms a closed path in conjunction with the above mentioned section of the edge 23 (refer to Figure 5). In this way, when the zip 18 is closed,  
30 the inside of the bag is hermetically sealed.

As illustrated, the front end of the channelling means 17 extends above the facilitated opening area 16 for a certain length and, in particular, this length is slightly greater than the  
length of the closing means 18.

Advantageously, retaining means are provided to keep the front end of the channelling means inside the bag after the outlet  
35 16 has been opened.

The retaining means that keep the front end of the channelling means inside the bag comprise the portion 12'a of the bag wall 12 located above the outlet 16 and designed to come into contact with and retain the front face 17'a of the front portion 17a of the channelling means when the latter are inside the bag and the outlet 16 is open.

As illustrated in particular in Figure 1, inside the bag, at the outlet 16, means are provided for housing the front portion 17a of the channelling means 17. The means for housing the front portion 17a of the channelling means consist of a wide chamber formed above the outlet 16.

The means for housing the front portion 17a of the channelling means are formed between the patch and the respective bag wall 12 and, more specifically, between the top of the patch 15 and the opposite portion of the wall 12.

The channelling means front portion 17a with the zip on it extends above the top of the facilitated opening area in such a way that the zip remains entirely above the top 16' of the facilitated opening area.

Figure 1 shows a cross section of a bag when it is opened for the first time. In this condition, the tubular element 17 is positioned inside the bag. The tear tab 19 is removed from the bag manually to form an opening 16 in the bag wall.

At this point, as shown in Figure 2, the end of the tubular element 17 can be pulled out through the opening 16 to give the bag user access to the zip 18.

Under these conditions, the zip 18 can be opened to form a dispensing channel through which the product can be poured out of the bag. In this connection, refer to Figure 3 which shows a front view of the bag 11 after the end of the tubular element 17 has been pulled out through the opening 16 and opened to allow the product to be poured out of the bag.

Notice that the tubular element provides extremely convenient means of directing the flow of the product (for example in granular form) while it is poured out of the bag. Once the desired amount of product has been poured out, the zip 18 can be closed, thus effectively sealing the inside of the bag thanks to

the presence of the patch 15. After closing the zip 18, the tubular element 17 can be pushed back into the bag to make it return to its original position before the bag was opened. Thus, the zip 18 does not remain exposed outside the bag 11 but is in a protected position inside the bag so it is practically impossible to open it by mistake (for example, by accidentally knocking it against the outside wall of the bag). Moreover, inside the bag, the zip is kept well clear of the bag wall.

Figure 4 shows a sheet of film 12 (usually from a flat web) that forms the wall of the finished bag 11. The patch 15 and the tubular element 17 are applied to the sheet 12 before the bag is formed.

Notice, at the back of the tubular element 17, the inlet 30 whose edge is sealed to the sheet of film 12 along the section 22 and to the patch 15 along the section 23. As mentioned above, the section 22 and the section 23 describe a closed path. In one embodiment of the invention, the tubular element 17 is made from two sheets of film 20 and 21, sealed along their edges to form a generic tube (see also Figure 5). In particular, the sheet 20 is sealed to the patch 15, whilst the sheet 21 is sealed to the inside face of the bag wall 12.

As mentioned above, the patch 15 is sealed to the tubular element 17 and also to the sheet 12 along the line 24. The sealed line 24 and the sealed line 22 form a closed path which runs all the way around the opening 16. This feature, as mentioned above, makes the tubular element 17 the only way to access the inside of the bag. It should be stressed that the patch 15 and the tubular element 17 can advantageously be applied to the film sheet 12 before the start of the bag forming process, that is to say, before the sheet of film 12 is fed into the bag forming machine.

The patch 15 and the tubular element 17 might advantageously be sealed to each other before being applied to the film sheet 12 and sealed as one to the film sheet 12.

These features greatly simplify the product packaging process and, consequently, the machinery required to form the bag. As mentioned above, the bag might be formed by any known type of vertical form/fill/seal machine especially suitable for packaging

products in granular form. However, a horizontal form/fill/seal machine might do the job equally well.

Figure 5 is a detail view showing an embodiment of the tubular element 17 to be used to make a bag according to the invention. This tubular element 17 consists of two sheets of plastic film 20 and 21, joined at the edges along sealed lines 40 and 41. In one embodiment of the invention, the sheet 21 might be larger than the sheet 20 so as to extend a little beyond the latter's lower edge, as shown in Figure 5. This would make it easier to seal the tubular element 17 to the bag wall when the sheet 20 is already applied to the patch 15.

Notice also that the two sheets 20 and 21 might be suitably shaped to be wider at the back end corresponding to the inlet 30. Thus, the tubular element is wider at the back, making it easier for the product inside the bag to be channelled into the inlet 30 towards the bag spout with the zip 18.

Notice also, with reference to Figure 1, that the patch 15 is not necessarily a separate part sealed to the tubular element 17, but the two might be made as a single part, in which case the seal 23 would be substituted by fold in the plastic film.

As illustrated, in the first preferred embodiment of the bag described above, the lower or inside end edge of the tubular element, that is to say, of the channelling means, forms an open inlet 30 even before the bag itself is opened.

In the second embodiment, illustrated in Figures 6 and 7, the tubular element 117 is made from a rectangular zipped profile 60 consisting of two superposed sheets of film joined at the top by a zip 18. By making two lateral hot cuts 61 and 62 in the profile 60, it is possible to form the two sides of the tubular element 117. The width of the tube is defined by the hot cuts so that the tube can be pulled out through the opening 16 in the bag wall 12 (dashed line) as shown in Figure 6. The tubular element 117 is then applied to the bag wall in the same way as in the first embodiment, described above, using a patch 115.

In other terms, as illustrated, the longitudinal cuts 61 and 62 extend only partly into the folded body 60, going in from the top of the latter. Along the cuts 60 and 61 there are sealed

longitudinal edges that form the sides of the tube 117. At the bottom end there is a large inlet opening 130 and, at the top end, a spout 117', shown open in Figure 7, having the same inside diameter as the tube 117.

5           As illustrated, the patch 115 in this embodiment is substantially equal in width to the body 60. A strip 124a at the top edge of the patch 115 is attached to the inside face of the wall 12, together with short upper side strips 124c and 124d of the patch 115 and lower side 122c, 122d of the tubular body 60, on  
10 the extension of the strips 124c, 124d.

          Another strip 122b at the bottom of the tubular body 60 is connected to the inside face of the bag wall 12, whilst lower side strips, not illustrated in detail, of the patch 115 may be connected to the tubular body 60 in the vicinity of the strips  
15 122c and 122d which connect the body 60 directly to the wall 12.

          Figure 8 illustrates a third embodiment 217 of the product channelling means, consisting, in this particular case, of a tubular channelling element having substantially straight sides converging towards the outlet. Said sides are sealed along  
20 straight lines 240 and 241 converging from the inlet 30 towards the spout 17' at the front and laterally connecting the sheets 220 and 221 forming the tubular element in this embodiment.

          In this way, the product to be poured of the bag can be channelled more effectively. In Figure 8, the parts that are similar to those of the first preferred embodiment are denoted by  
25 the same reference numerals and, for brevity, are not described in detail again. In practice, in the third embodiment, the tubular element 217 is applied to the bag between the plastic film patch 15 and the front bag wall 12 in exactly the same position and in exactly the same way as the tubular element 17 of the first  
30 embodiment described above.

          Figures 9 and 10 illustrate a fourth embodiment 317 of the channelling means. In Figures 9 and 10, the parts that are similar to those of the embodiments already described are denoted by the  
35 same reference numerals and, for brevity, are not described in detail again. In practice, in the fourth preferred embodiment, the tubular channelling element 317 has a first surface 322 joining

the front of it to the inside face of the wall 12, whilst a second surface 323 joining the part of the channelling element 317 facing the inside of the bag to the patch 315 extends at substantially the same level as the first surface 322 joining it to the front wall 12, both these surfaces remaining below the opening 17.

As illustrated, in this fourth preferred embodiment, the patch 315, being generally T-shaped, differs in shape from the patches of the embodiments described above. As shown, the patch 315 of this embodiment comprises an outline with an upper edge 324a and opposite lateral edges. In particular, each lateral edge of the patch 315 has a first upper section 324b and a second lower section 324c - the latter being indented towards the centre of it and relative to the first section - both sections extending in a direction that is substantially vertical or parallel to the sides of the bag.

More specifically, the first upper section 324b is attached to the inside face of the wall 12, whilst the second, indented section 324c is attached to the rear, inward facing end 21 of the tubular element 317.

The first upper section 324b and the second indented section 324c are joined to each other by an intermediate, substantially horizontal section 324d, which is parallel to the upper and lower ends of the bag and which is attached to the inside face of the wall 12.

Further, as illustrated, the tubular element 317 has lateral seals which give it its tubular shape, only one of the lateral seals of the tubular element is shown in Figure 9, the one labelled 317b. The tubular element also has, on its portion 20, a lower seal 322 which attaches it to the inside face of the wall 12, the seal 323 being located, as shown in Figure 9, between the inside portion 21 of the tubular element and the patch 315.

Thus less plastic film is required to make the patch 315, with obvious advantages in terms of savings on material.

The reference numerals 317' and 330 in the drawings respectively denote the spout and the inlet of the channelling means.

In the fourth preferred embodiment, a part of the

channelling means extends in a direction parallel to the bag wall 12. Therefore, the channel does not lead directly out of the bag but advantageously causes the product to follow a curved path, which more effectively controls the flow of product as it moves  
5 towards the outlet opening. This is the most effective solution to the problem of pouring too much product out of the bag all at once.

Figure 11 illustrates a fifth embodiment 417 of the means for channelling the product out of the bag. In Figure 11, the  
10 parts that are similar to those of the embodiments already described are denoted by the same reference numerals and, for brevity, are not described in detail again.

As illustrated, in the fifth preferred embodiment, the  
15 second joining surface 423 of the flange 421 of the channelling element 417 is connected directly to the inside face 12' of the wall 12 at a point above the opening 16, whilst the first joining surface 422 of the flange 420 of the channelling element 417 connects the other flange 420 of the channelling element 417 directly to the inside face 12' of the wall 12 at a point below  
20 the opening 16.

When the bag is reclosed after being opened, the front end 417a of the tubular element 417 is folded down and is retained between the central or lower part of the lower flange 420 and the opposite inside face of the wall 12, extending under the opening  
25 16.

In the fifth preferred embodiment the invention contemplates the provision of sealing means designed to be opened when the bag is opened for the first time.

Said sealing means comprise a patch 415 that extends at the  
30 back of the channelling means, running all the way around the latter and removably connected, along its edges, to the inside surface of the wall 12.

In particular, as illustrated, the sealing patch 415 is connected at the top and bottom to the part of the flanges 420 and  
35 421 facing the inside of the bag by respective tearable seals 415a, 415b or peel-off closures.

In another preferred embodiment that is not illustrated in

the accompanying drawings, the sealing means are defined by the patch itself, which constitutes means for attaching the channelling means to the bag. In practice, with reference to the embodiment shown in Figure 10, the patch 15 might be extended  
5 downwardly past the lower edge 322, 323 of the channelling means and attached directly to the inside face of the wall 12 below the channelling means themselves. The downwardly extended part of the patch 15 attached to the wall 12 can then be provided with a tear-off or peel-off seal that can be easily removed in order to access  
10 the inside of the bag.

Figures 12 to 14 illustrate a sixth embodiment 517 of the means for channelling the product out of the bag. In Figure 12, the parts that are similar to those of the embodiments already described are denoted by the same reference numerals and, for  
15 brevity, are not described in detail again.

The sixth preferred embodiment comprises a tubular element 517 that does not have a zip or any other form of closure on it.

The tubular element 517 is made by joining two sheets 520a, 521a, preferably of plastic film, with respective longitudinal  
20 portions 520' and 521' lying in the same plane and aligned with each other, and respective transversal portions 520" and 521", facing each other and joined along their side lateral portions 540, 541 to form a central tubular zone delimited by the central end flap 520 of the upper sheet 520a and by the central end flap  
25 521 of the lower sheet 521a.

As illustrated, the channelling means are attached to the respective wall by joining an upper strip 524a of the sheet 520a and a lower strip 524b of the sheet 521a to the inside face of the wall 12. Lateral strips 524c', 524c" and 524d', 524d", which are  
30 aligned with each other and form part of the longitudinal portions 520' and 521', are also attached to the inside face of the wall 12.

As illustrated, the channelling means 517 are preferably fixed to the bag wall in such a way that the inlet 530 is below  
35 the outlet opening 16 and the spout 517' extends above the outlet opening 16. Alternatively, the inlet 530 might be positioned above the outlet opening 16 and the spout 517' below it.

Partial closure of the tubular element 517 after removing the tear tab to open the bag for the first time and pouring some of the product out can advantageously be accomplished, providing a sufficiently good seal in certain situations, by folding the front end 517a of the tubular element onto itself and pushing the tubular element 517 back into the bag where it remains trapped in the folded condition between the longitudinal portion 520' of the upper sheet, or between the longitudinal portion 521' of the lower sheet, and the corresponding inside surface of the bag wall 12. If necessary, a partial closure of this kind can be accomplished without actually folding the front end 517a of the tubular element 517 onto itself.

As shown in Figure 14, to pull the tubular element out through the opening 16, the sealed lateral areas 540, 541 which keep the tubular element 517 against inside face of the wall 12 must be pulled apart slightly at the sides of the opening 16.

The tubular element of this embodiment is extremely simple to make. The spout 517' protruding from the front end can be obtained without any effort by elastically deforming the lateral seals 540, 541 of the transversal portions of the sheets.

In another embodiment that is not illustrated, the channelling means are substantially the same as those of the sixth preferred embodiment just described but without the lateral seals 540 and 541 and the tubular channelling element consists of two lips 520 and 521, separated from each other at the sides and extending perpendicularly from respective longitudinal sheets 520' and 521' which are internally sealed to the wall 12 in the same way as that already described.

First of all, it is provided a re-closable bag that can be made according to a simple process that does not require complex packaging machinery. Indeed, the tubular element that provides the spout which can be re-closed after opening and from which the product can be dispensed from the bag, can be applied to the film web before the web is fed to the form/fill/seal machine which uses the web to make the bag.

Further, the bag according to the invention is extremely handy: the tubular element is easy to pull out after the bag has

been opened and allows the product (for example in granular form) to be poured out of the bag while easily controlling its quantity and direction of flow.

5 Lastly, the re-closable bag provided by the invention optimises product storage life and minimises the risk of accidentally opening the zip once the bag has been opened. The tubular element with the zip on it can be pushed back into the bag through the opening made in the bag wall when the bag is opened for the first time. This protects the zip against accidental  
10 knocks that might cause it to open by mistake. Notice that the part of the tube to which the zip is applied is connected to the outside walls of the bag along a relatively long section of the tube, so that even a knock against the bag wall will not in most cases re-open the zip accidentally. In other terms, shocks due to  
15 rough handling of the bag will not usually be propagated to the zip inside the bag. It is evident that the embodiments described above are examples of how the innovative principles of the invention can be applied and must in no way be construed as restricting the spirit of the invention as claimed herein.

20 For example, the tubular element might be made in different shapes, not necessarily like the ones described above. The outlet opening made when the bag is opened for the first time might also have other shapes, not necessarily the long, slot-like shape described above.

25 It will also be understood that, although the bag according to the invention is designed in particular to contain a product in granular form, its use for other kinds of products, for example a product in pieces or in powder form or a paste or a liquid or semi-liquid product, might also be imagined.

30 Therefore, the invention can be adapted and modified in several ways without thereby departing from the scope of the inventive concept. Moreover, all of the details of the invention may be substituted by technically equivalent elements.

Claims

1. A bag for containing a product, in particular a food product, preferably in granular form; the bag having a body, made preferably from at least one sheet of plastic film, defining an internal space (11') for holding the product and having an outlet opening (16) through which the product comes out; the bag being  
5 characterised in that it comprises means (17) for channelling the product out of it.

2. The bag according to claim 1, characterised in that the  
10 means for channelling the product out of the bag consist of a tubular element (17).

3. The bag according to any of the foregoing claims, characterised in that the product channelling means (17) present a  
15 spout used for pouring the product out of the bag and located at the front end of the channelling means.

4. The bag according to any of the foregoing claims, characterised in that the product channelling means (17) present  
20 an inlet used for guiding the product into the channelling means and located at the rear end of the tubular element.

5. The bag according to any of the foregoing claims, characterised in that the front end of the channelling means  
25 extends to the product outlet opening (16).

6. The bag according to any of the foregoing claims, characterised in that the bag body has at least one front wall and  
one rear wall.

30

7. The bag according to any of the foregoing claims, characterised in that the bag body has a facilitated opening area that forms an outlet opening (16) in the respective bag wall.

8. The bag according to any of the foregoing claims, characterised in that the product channelling means (17) comprise a front end portion (17a) that extends outside the bag through the opening (16).

5

9. The bag according to any of the foregoing claims, characterised in that the product channelling means (17) comprise a front end portion (17a) that can be pulled out of the bag through the opening (16).

10

10. The bag according to any of the foregoing claims, characterised in that at least the rear end portion (17b) of the means (17) for channelling the product out of the bag is located inside the bag.

15

11. The bag according to any of the foregoing claims, characterised in that the means (17) for channelling the product out of the bag extends for a certain length inside the bag.

20

12. The bag according to any of the foregoing claims, characterised in that the means (17) for channelling the product out of the bag remain close to the wall (12) in which the outlet opening (16) is made.

25

13. The bag according to any of the foregoing claims, characterised in that the channelling means (17) extend in a direction substantially parallel to the respective bag wall (12).

30

14. The bag according to any of the foregoing claims, characterised in that, during use, the channelling means (17) have a first section (17b) and a second section (17a) transversal to the first section.

35

15. The bag according to any of the foregoing claims or according to the preamble to claim 1, characterised in that the channelling means have closing means that can be opened and re-closed.

16. The bag according to claim 15, characterised in that the closing means consist of a zip.
- 5 17. The bag according to claim 15 or 16, characterised in that the closing means are provided at the spout (17') of the channelling means.
- 10 18. The bag according to any of the foregoing claims, characterised in that the inlet (30) to the channelling means have an edge (22, 23) with a part (22) that extends further towards the bottom of the bag.
- 15 19. The bag according to claim 18, characterised in that the part (22) that extends further towards the bottom of the bag is the part of the edge located at the respective bag wall (12).
- 20 20. The bag according to any of the foregoing claims, characterised in that the inlet (30) to the channelling means have an edge (22, 23) that extends entirely under the bag opening (16).
- 25 21. The bag according to any of the foregoing claims, characterised in that the inlet (30) to the channelling means is wider than the spout (17') at the outlet end.
- 30 22. The bag according to any of the foregoing claims, characterised in that the channelling means have sides (17c, 17d) that converge towards the front end of the channelling means.
- 35 23. The bag according to any of the foregoing claims from 1 to 20, characterised in that the inlet (30) and the spout (17') are substantially equal in width.
24. The bag according to claim 23, characterised in that the channelling means have sides (17c, 17d) that are substantially parallel to each other.

25. The bag according to any of the foregoing claims, characterised in that the inlet (30) to the channelling means is narrower than the respective bag wall (12).
- 5 26. The bag according to any of the foregoing claims, characterised in that it comprises means for connecting the channelling means to the bag.
- 10 27. The bag according to claim 26, characterised in that the means for connecting the channelling means (17) run all the way around the opening (16) so that the product can come out of the bag only through the channelling means.
- 15 28. The bag according to claim 26 or 27, characterised in that the means for connecting the channelling means (17) comprise a respective surface (22) forming part of the channelling means (17) and positioned face to face and in contact with the inside surface (12') of the respective wall (12) it is joined to.
- 20 29. The bag according to claim 28, characterised in that the surface (22) for joining the channelling means (17) is attached to the respective wall (12) below the bag opening (16).
- 25 30. The bag according to claim 28 or 29, characterised in that the surface by which the channelling means (17) are attached to the wall (12) is defined by a portion (22) at the rear edge of the channelling means.
- 30 31. The bag according to any of the foregoing claims from 26 to 30, characterised in that the means for connecting the channelling means (17) to the respective bag wall comprise a second surface (23) of the channelling means (17).
- 35 32. The bag according to claim 31, characterised in that the second surface (23) for joining the channelling means (17) is defined by a portion (23) of the rear edge of the channelling means.

33. The bag according to claim 31 or 32, characterised in that the second surface (23) for joining the channelling means (17) extends below the bag opening (16).

5

34. The bag according to any of the foregoing claims from 31 to 33, characterised in that the second surface (23) for joining the channelling means (17) extends above the first joining surface (22).

10

35. The bag according to any of the foregoing claims from 31 to 33, characterised in that the second surface (323) for joining the channelling means (317) extends at substantially the same level as the first joining surface (322).

15

36. The bag according to any of the foregoing claims from 31 to 34, characterised in that the second surface (423) for joining the channelling means (417) is connected directly to the inside surface (412') of the respective bag wall (412) at a point above the opening (16).

20

37. The bag according to any of the foregoing claims from 31 to 36, characterised in that the second surface for joining the channelling means is connected to the inside surface of the opposite wall (10).

25

38. The bag according to any of the foregoing claims or according to the preamble to claim 1, characterised in that it comprises a patch (15) that extends at the opening (17).

30

39. The bag according to claim 38, characterised in that the patch (15) constitutes means for attaching a respective joining surface (23) of the channelling means (17).

35

40. The bag according to claim 39, characterised in that the second surface (23) for joining the channelling means (17) is attached to a respective joining patch (15).

41. The bag according to any of the foregoing claims from 38 to 40, characterised in that the joining patch (15) is connected to the inside surface of the respective bag wall (12) at a point  
5 above the opening (16).

42. The bag according to any of the foregoing claims from 38 to 41, characterised in that the joining patch (15) is connected to the inside surface of the respective bag wall (12) at a point on  
10 one side of the opening (16).

43. The bag according to any of the foregoing claims from 38 to 42, characterised in that the joining patch (15) is connected to the inside surface of the respective bag wall (12) at a point  
15 below the opening (16).

44. The bag according to claim 43, characterised in that the joining patch (15) is connected to the inside surface of the respective bag wall (12) below the opening (16) at a point on one  
20 side of the channelling means (17).

45. The bag according to any of the foregoing claims from 38 to 44, characterised in that the patch surrounds the opening (16).

25 46. The bag according to any of the foregoing claims from 38 to 45, characterised in that the patch (15) has at least one portion extending past the edge of the channelling means.

30 47. The bag according to any of the foregoing claims, characterised in that the channelling means comprise two sheets of plastic film (20, 21) sealed along opposite edges to form a generic tube.

35 48. The bag according to claim 47, characterised in that the edge section (22) joined to the respective bag wall (12) lies on the first sheet (21) of the two sheets that form the channelling means (17).

49. The bag according to claim 47 or 48, characterised in that the first sheet (21) that forms the channelling means protrudes from the second at the back of the tubular element, thereby forming a flap which is attached to the inside face of the bag wall (12).

50. The bag according to any of the foregoing claims, characterised in that the outlet opening (16) is elongated and extends in a straight line.

51. The bag according to any of the foregoing claims, characterised in that the front portion (17a) of the channelling means is narrower than the outlet opening (16) is long.

52. The bag according to any of the foregoing claims, characterised in that the front portion (17a) of the channelling means with the re-closable spout is just a little narrower than the outlet opening (16) is long.

53. The bag according to any of the foregoing claims, characterised in that the back of the channelling means is wider than the outlet opening (16) is long.

54. The bag according to any of the foregoing claims, characterised in that the facilitated opening area comprises a film tear tab connected to the bag wall by a weakened film portion.

55. The bag according to any of the foregoing claims from 15 to 54, characterised in that the closing means comprise a part which protrudes from one of the two sheets (20, 21) forming the channelling means (17) and which is designed to engage with a second part that protrudes from the other of the two sheets (20, 21) forming the channelling means.

56. The bag according to any of the foregoing claims, characterised in that the front end of the channelling means (17) extends for a certain length above the facilitated opening area (16).
- 5
57. The bag according to any of the foregoing claims, characterised in that the front end of the tubular element extends above the facilitated opening area for a certain length that greater than the length of the closing means (18).
- 10
58. The bag according to any of the foregoing claims, characterised in that it comprises retaining means for keeping the front end of the channelling means inside the bag.
- 15
59. The bag according to claim 58, characterised in that the retaining means for keeping the front end of the channelling means inside the bag comprise a portion (12'a) of the respective bag wall (12) above the opening (16).
- 20
60. The bag according to claim 58, characterised in that the retaining means for keeping the front end of the channelling means inside the bag comprise the portion (12'b) of the respective bag wall (12) below the opening (16).
- 25
61. The bag according to any of the foregoing claims, characterised in that inside the bag, at the outlet opening (16), means are provided for housing the front portion (17a) of the channelling means (17).
- 30
62. The bag according to claim 61, characterised in that the means for housing the channelling means (17a) consist of a large chamber.
- 35
63. The bag according to claim 61 or 62, characterised in that the means for housing the channelling means (17a) are located above the opening (16).

64. The bag according to claim 61 or 62, characterised in that the means for housing the channelling means (17a) are located below the opening (16).

5 65. The bag according to any of the foregoing claims from 61 to 64, characterised in that the means for housing the channelling means (17a) are located between the patch and the respective bag wall (12).

10 66. The bag according to any of the foregoing claims from 61 or 65, characterised in that the housing means are located between the front surface of the intermediate, rear part of the channelling means and the respective bag wall (12).

15 67. The bag according to any of the foregoing claims, characterised in that the channelling means have substantially straight sides (217c, 217d) that converge towards the outlet.

20 68. The bag according to any of the foregoing claims or according to the preamble to claim 1, characterised in that it comprises means (415) for sealing the bag.

25 69. The bag according to claim 68, characterised in that the sealing means extend in such a way as to seal off the inside of the bag from the outlet opening (16).

30 70. The bag according to claim 68 or 69, characterised in that the sealing means comprise a patch (415) extending at the back of the channelling means and running all the way around the latter.

35 71. The bag according to any of the foregoing claims from 68 to 70, characterised in that the sealing means (415) are removably connected to the inside surface of the respective bag wall (12) at a point near the channelling means (417).

72. The bag according to any of the foregoing claims from 68 to 71, characterised in that the sealing means comprise a patch (415) that is held to the closing means (417) of the bag.

5 73. The bag according to any of the foregoing claims from 68 to 72, characterised in that the sealing means comprise a patch that constitutes means for attaching the channelling means to the bag.

10 74. The bag according to any of the foregoing claims, characterised in that channelling means (117) are made from a profile (60) consisting of two superposed sheets of film joined at the top by a zip (61, 62) or other closing means.

15 75. The bag according to any of the foregoing claims, characterised in that the channelling means (117) are obtained by making two lateral cuts (61, 62) in a pair of sheets placed over each other.

1/6

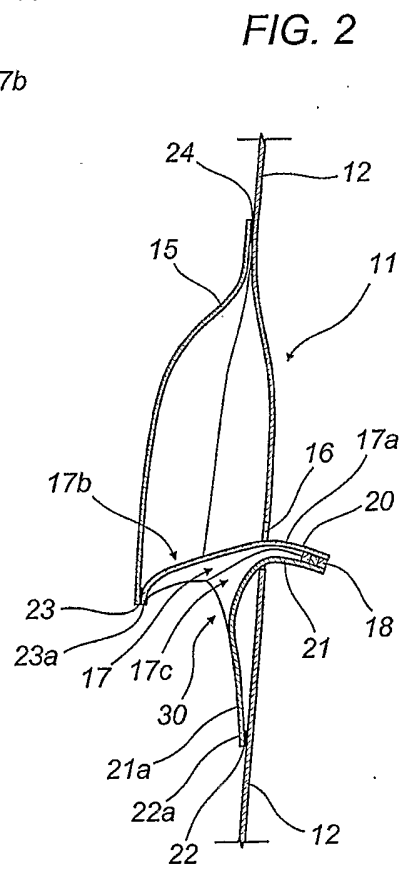
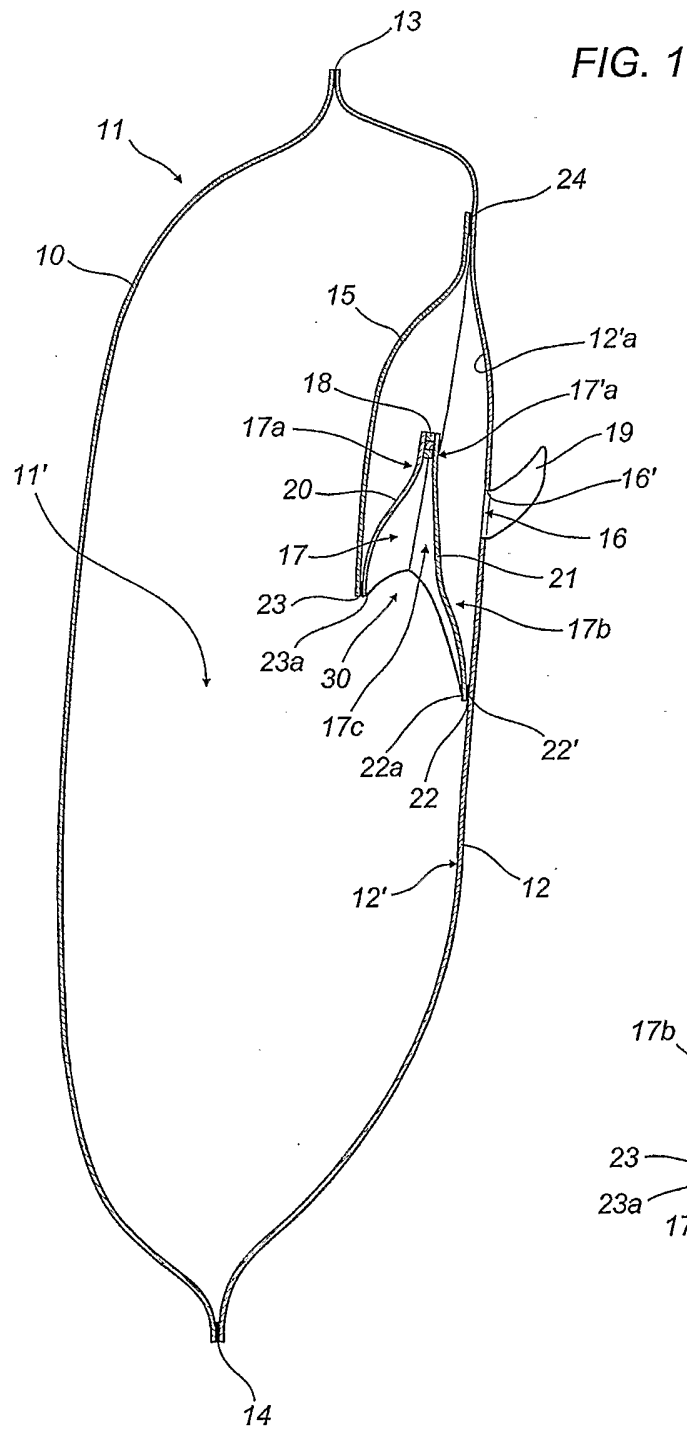

2/6

FIG. 3

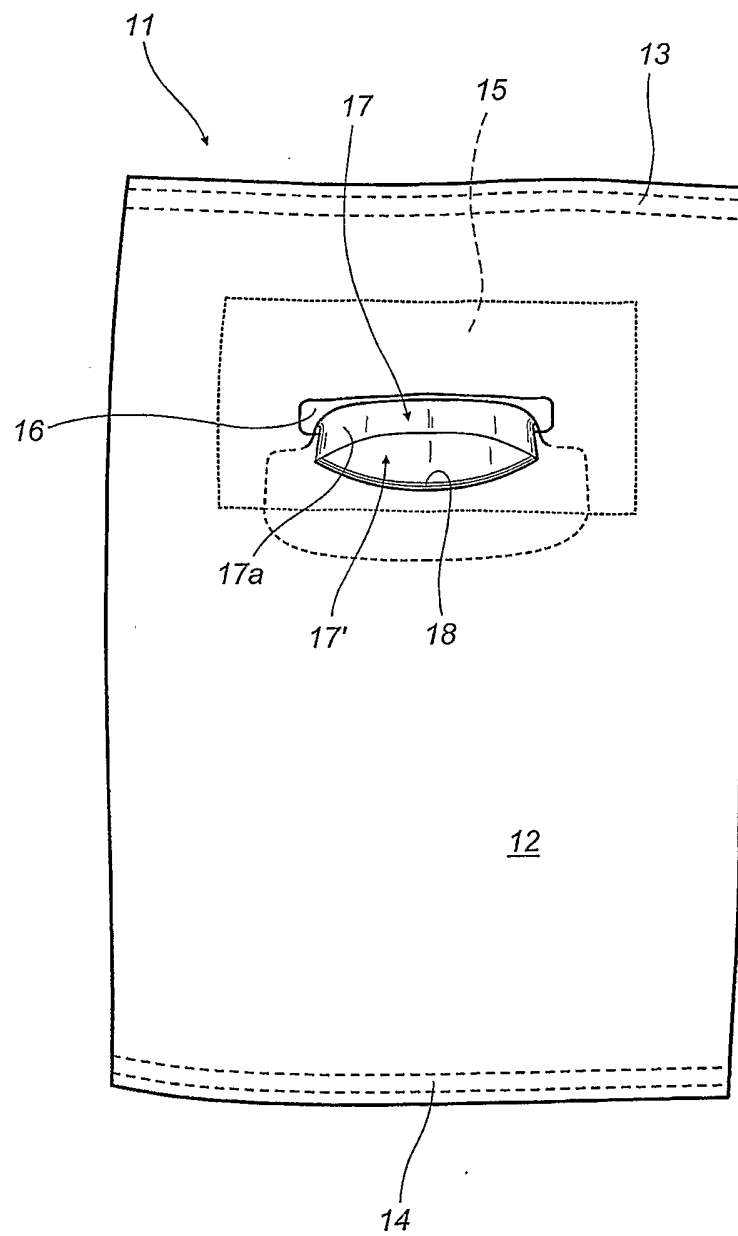

FIG. 4

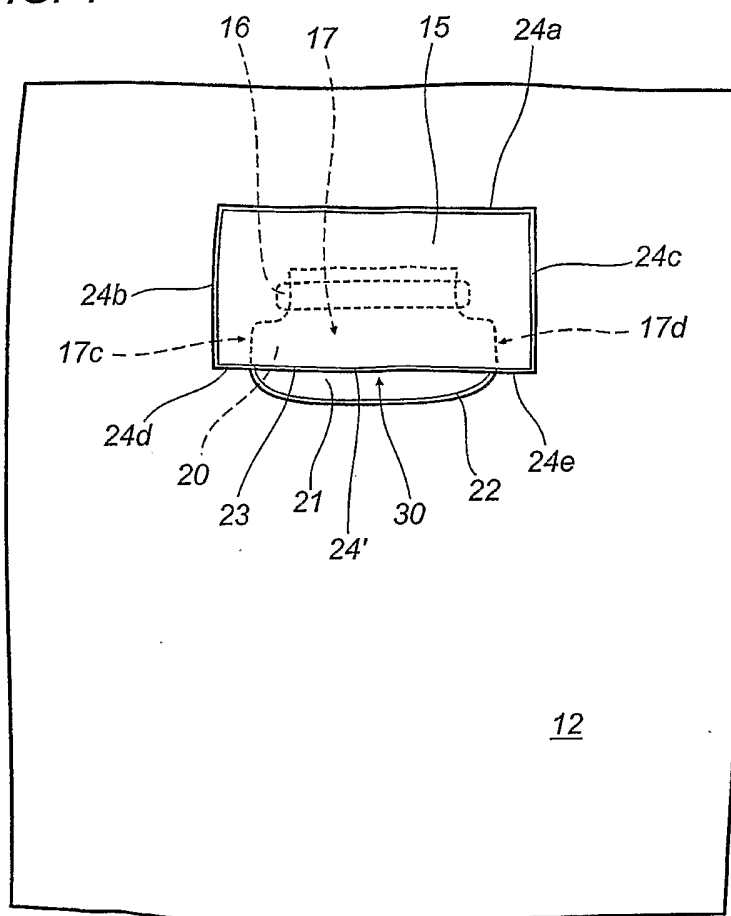

FIG. 5

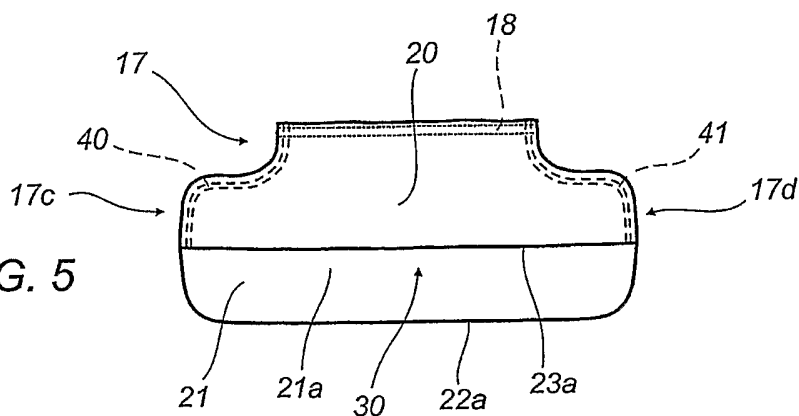

FIG. 6

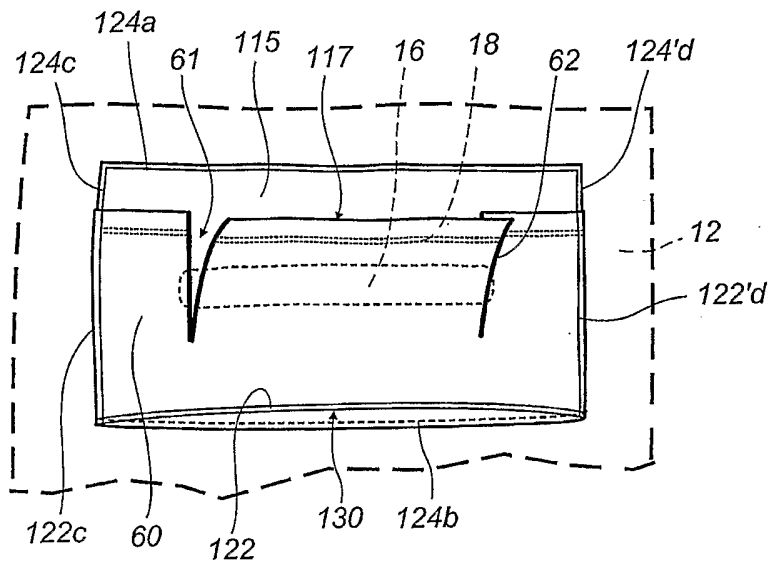

FIG. 7

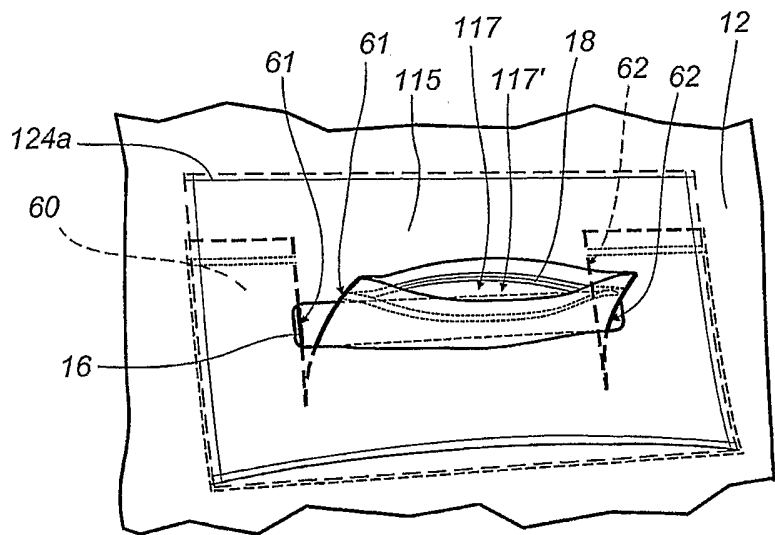
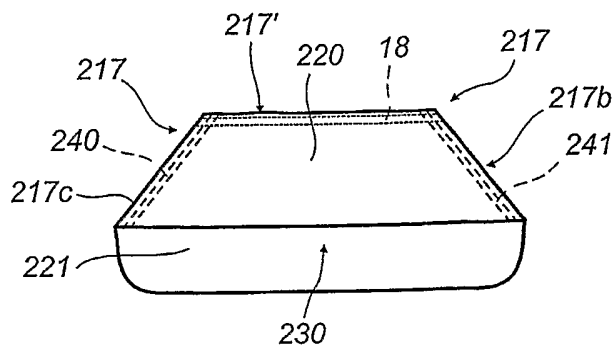

FIG. 8



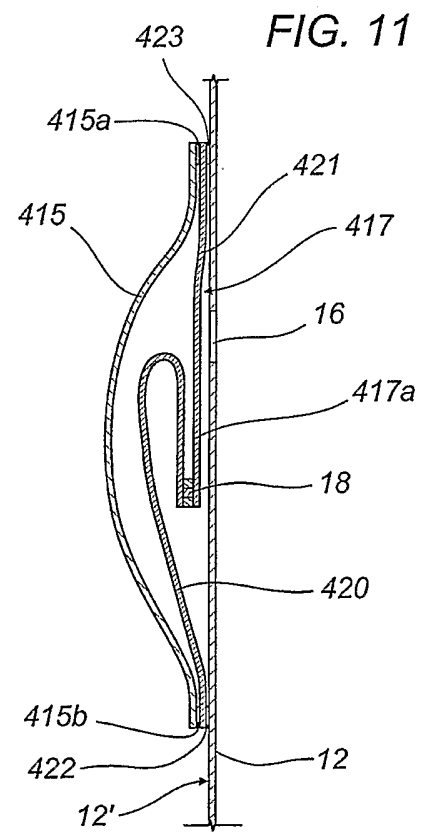
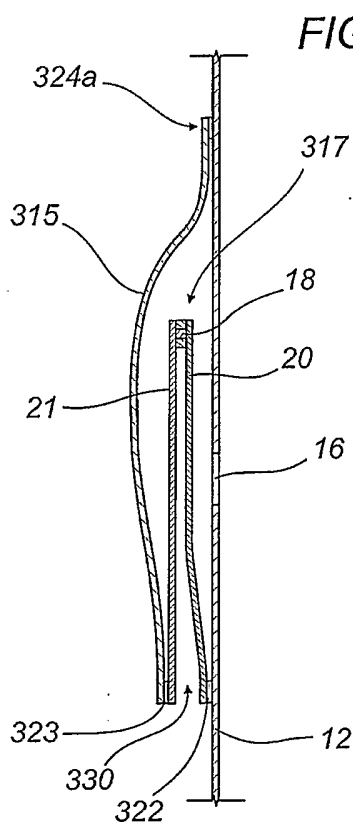
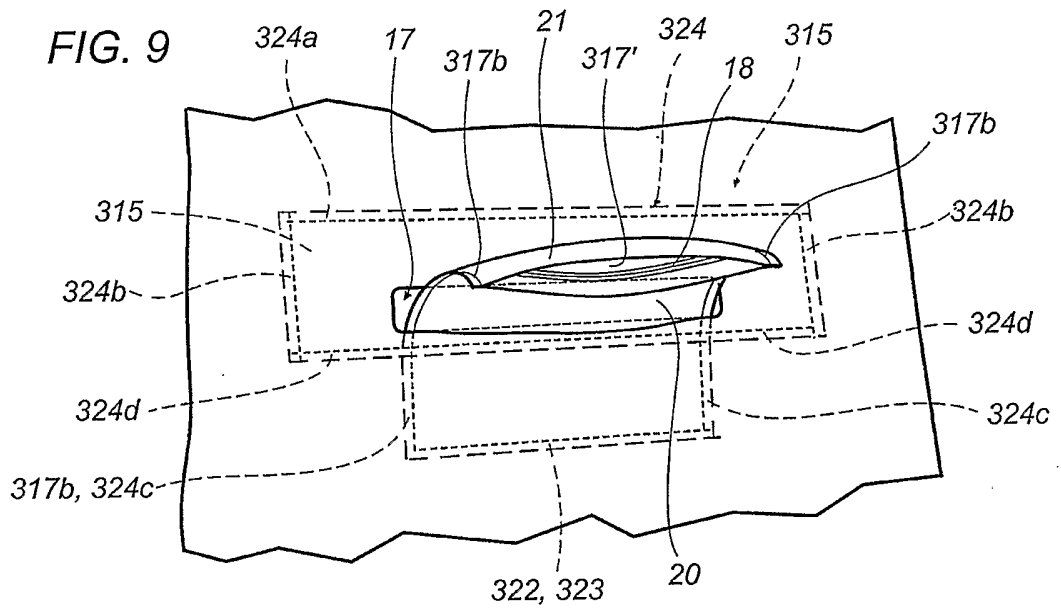

FIG. 12

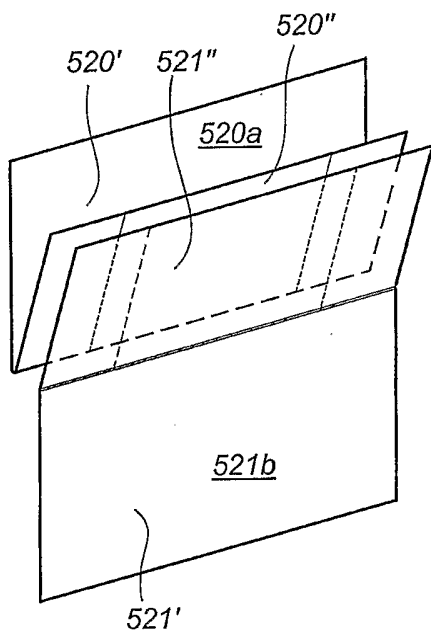

FIG. 13

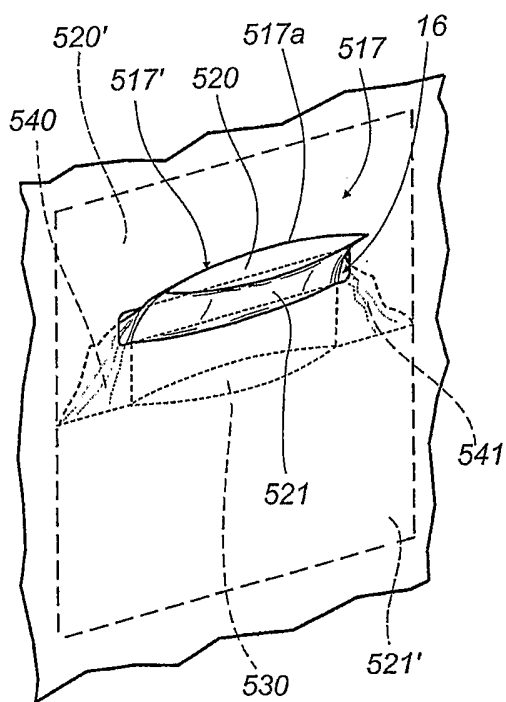
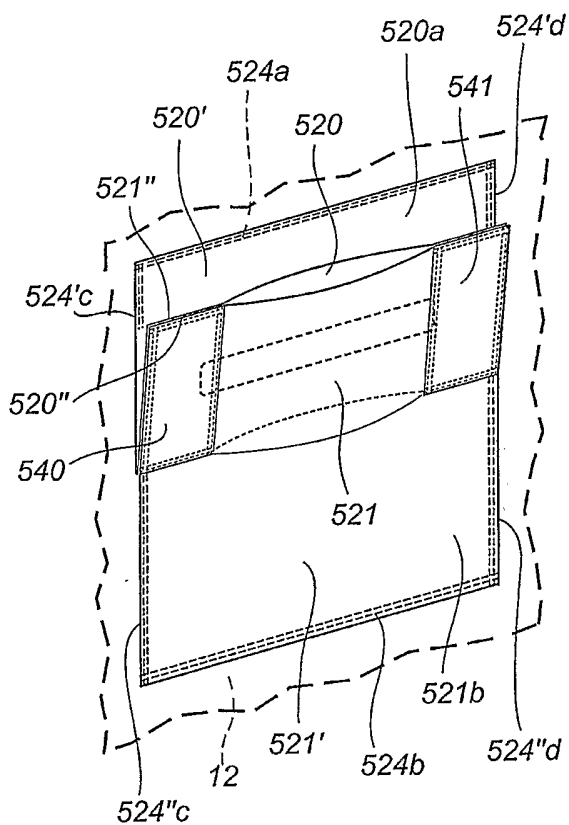

FIG. 14