

(19) World Intellectual Property Organization
International Bureau



(10) International Publication Number
WO 2010/003136 A1

(43) International Publication Date
7 January 2010 (07.01.2010)

(51) International Patent Classification:
F02M 11/06 (2006.01)

(21) International Application Number:
PCT/US2009/049640

(22) International Filing Date:
2 July 2009 (02.07.2009)

(25) Filing Language: English

(26) Publication Language: English

(30) Priority Data:
61/078,281 3 July 2008 (03.07.2008) US

(71) Applicant (for all designated States except US): **FUEL SAVING TECHNOLOGIES, LLC** [US/US]; 1011 Hoa Street, Honolulu, HI 96825 (US).

(72) Inventors; and

(75) Inventors/Applicants (for US only): **YU, Jeffrey, N.** [US/US]; 1011 Hoa Street, Honolulu, HI 96825 (US). **HILL, James, W.** [US/US]; 18191 Von Karman Avenue, Suite 500, Irvine, CA 92612 (US).

(74) Agent: **HILL, James, W.**; McDermot Will & Emery LLP, 18191 Von Karman, Suite 500, Irvine, CA 92612 (US).

(81) Designated States (unless otherwise indicated, for every kind of national protection available): AE, AG, AL, AM, AO, AT, AU, AZ, BA, BB, BG, BH, BR, BW, BY, BZ, CA, CH, CL, CN, CO, CR, CU, CZ, DE, DK, DM, DO, DZ, EC, EE, EG, ES, FI, GB, GD, GE, GH, GM, GT, HN, HR, HU, ID, IL, IN, IS, JP, KE, KG, KM, KN, KP, KR, KZ, LA, LC, LK, LR, LS, LT, LU, LY, MA, MD, ME, MG, MK, MN, MW, MX, MY, MZ, NA, NG, NI, NO, NZ, OM, PE, PG, PH, PL, PT, RO, RS, RU, SC, SD, SE, SG, SK, SL, SM, ST, SV, SY, TJ, TM, TN, TR, TT, TZ, UA, UG, US, UZ, VC, VN, ZA, ZM, ZW.

(84) Designated States (unless otherwise indicated, for every kind of regional protection available): ARIPO (BW, GH, GM, KE, LS, MW, MZ, NA, SD, SL, SZ, TZ, UG, ZM, ZW), Eurasian (AM, AZ, BY, KG, KZ, MD, RU, TJ, TM), European (AT, BE, BG, CH, CY, CZ, DE, DK, EE, ES, FI, FR, GB, GR, HR, HU, IE, IS, IT, LT, LU, LV, MC, MK, MT, NL, NO, PL, PT, RO, SE, SI, SK, SM, TR), OAPI (BF, BJ, CF, CG, CI, CM, GA, GN, GQ, GW, ML, MR, NE, SN, TD, TG).

Published:

— with international search report (Art. 21(3))

(54) Title: FUEL CONSERVATION SYSTEMS AND METHODS

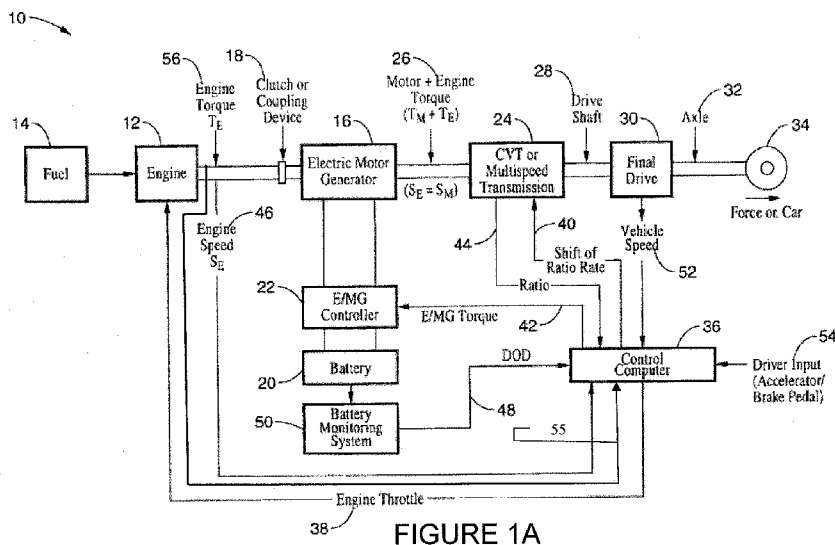

(57) Abstract: Methods and systems are described for conserving fuel used by an engine. In some embodiments a control module processes a user-provided input, as a first function, into a second function. The second function can be used to direct the engine with a directive output power. The directive output power may have regions equal to, greater than, and/or less than what the power output would be if the engine were controlled using the user-provided input.

WO 2010/003136 A1

079979-0013

PATENT

FUEL CONSERVATION SYSTEMS AND METHODS

Cross References to Related Applications

[0001] The present application claims the benefit of U.S. Provisional Patent Application Serial No. 61/078,281, entitled "FUEL CONSERVATION SYSTEMS AND METHODS," filed on July 3, 2008, which is hereby incorporated by reference in its entirety for all purposes.

Field of the Invention

[0002] Embodiments of the inventions generally relate to engines and, in particular, fuel conservation systems and methods for engines.

Background of the Invention

[0003] Fossil fuels allow for production and delivery of food and products worldwide. From cargo ships to diesel locomotives, tractor-trailers, and the everyday automobile, the world runs on combustible gas, and typically fossil fuel. As nations move toward securing prosperity for their people, as attempts are made for an increased standard of living, as machines of industry continue to produce articles of need and want, the market for oil steadily grows. Gas prices will continue to rise if demand depletes oil reserves. A rise in fuel costs comes with staggering consequences, including a corresponding rise in the cost to make and deliver food and products. Many rational observers argue that the safety, security, and well-being of entire generations hangs at a precipice of near-total reliance upon fossil fuels.

[0004] Internal combustion engines depend upon the availability of fossil fuels. The first internal combustion engine was perhaps contemplated by Al-Jazari in 1206. In *The Book of Knowledge of Ingenious Mechanical Devices*, he described a reciprocating pump and crankshaft device. Leonardo da Vinci described a compressionless engine in the 16th century. A patent for an internal combustion engine for industrial applications was

granted to Samuel Brown in 1823. A modern search of patents and patent applications reveals a proliferation of interest in the field of internal combustion engines, yet another metric useful for describing the demands that are pressing in from all sides, causing the price of gas to reach astronomical heights.

Summary of the Invention

[0005] In accordance with certain embodiments, a fuel conservation system and method for internal combustion engines is provided. In certain embodiments the fuel conservation system and method may apply to a cruise control module, a programmable logic controller, and/or an engine control unit. Certain embodiments may dampen and/or cut fuel delivery to an internal combustion engine. In certain embodiments an electric motor may substantially maintain a horsepower or torque output of an internal combustion engine when reducing, moderating, tapering, oscillating, cycling, cutting and/or dampening fuel delivery to an internal combustion engine. Certain embodiments may be selectively tunable, and may include a feedback loop to display information relative to the possibility of and/or achievement of fuel savings. Certain embodiments of the inventions may include a user-selectable override, causing the internal combustion engine to make available, on demand from a user, the greatest amount of output power possible from the engine.

[0006] In a certain embodiment, a method is provided for conserving fuel used by an engine. The method includes receiving as an input to an engine power module a first function comprising a user-specified power output of an engine over a time duration. In certain embodiments, the input may come from an accelerator pedal or throttle position. In certain embodiments, the time duration may be instantaneous. The method includes processing the first function into a second function comprising a directive power output of the engine over the time duration. The second function has at least one region of equal or increased engine power output relative to the user-specified engine power output, and the second function also has at least one region of decreased engine power output relative to the user-specified engine power output, so that, if the engine outputs power equal to the directive power output of the engine over the time duration, the engine consumes less fuel than the engine would have consumed if the engine outputted power equal to the user-specified power output of the engine over the time duration. The method includes

outputting, to an engine control module, the second function, such that the engine outputs power according to the directive power output of the engine over the time duration.

[0007] In a certain embodiment, the method includes displaying to a user an indication of a possibility or achievement of fuel savings by the engine if the engine outputs power according to the directive power output of the engine. In a certain embodiment, the method includes providing an actuator that permits the user to override the fuel savings. In a certain embodiment, the method includes the aspect of the input to the engine power module including a cruise-control setting by a user. In a certain embodiment, the method includes the aspect of the user-specified power output of the engine being based on a cruise-control setting by a user. In a certain embodiment, the method includes supplementing an output of the engine with output generated by an electric motor while the engine outputs power according to the directive power output of the engine. In a certain embodiment, the method includes supplementing a power output of the engine with power from an electric motor while the engine outputs power according to the directive power output of the engine. In a certain embodiment, the method includes processing the second function for smoothness. In a certain embodiment, the method includes supplementing a power output of the engine with power from a motor different from the engine while the engine outputs power according to the directive power output of the engine. In a certain embodiment, the processing of the first function into the second function includes application of a transform T , such that $F_2(n) = T F_1(n)$, where F_2 is the second function; F_1 is the first function; n is an ordered index number of an n th discrete sample, where $n \in \{0, 1, 2, \dots, \infty\}$; and wherein T comprises $(ke^{-2\pi i \Omega (n-d)} - Z)$, where k is a constant; e is an exponential; i is the imaginary number $\sqrt{-1}$; Ω is a frequency of cycles per sample interval (e.g., the time interval between the n th and the $n+1$ th sample); Z is a constant; and d is a delay constant.

[0008] In a certain embodiment, an engine control system includes means for receiving, as an input, a first function comprising a user-specified power output of an engine over a time duration. In some embodiments, the system includes means for processing the first function into a second function comprising a directive power output of the engine over the time duration. The system includes the second function having at least one region of equal or increased engine power output relative to the user-specified engine power output, and at least one region of decreased engine power output relative to the user-specified

engine power output, such that, if the engine outputs power equal to the directive power output of the engine over the time duration, the engine consumes less fuel than the engine would have consumed if the engine outputted power equal to the user-specified power output of the engine over the time duration. The system includes means for outputting, to an engine control module, the second function, such that the engine outputs power according to the directive power output of the engine over the time duration.

[0009] In a certain embodiment, the system includes means for informing the user of a possibility or achievement of fuel saving by the engine if the engine outputs power according to the directive power output of the engine. In a certain embodiment, the system includes means for supplementing an output of the engine with output generated by a motor different from the engine during outputting of the second function. In a certain embodiment, the motor comprises an electric motor. In a certain embodiment, the system includes the aspect that the input comprises a cruise-control setting by a user. In a certain embodiment, the system includes the aspect that the user-specified power output of the engine is based on a cruise-control setting by a user. In a certain embodiment, the system includes means for outputting the second function for a duration of time greater than a duration of time that the input is input to the means for receiving. In a certain embodiment, the system includes means for processing the second function for smoothness. In a certain embodiment, the system includes means for supplementing an output of the engine with output generated by a motor different from the engine during outputting of the second function. In a certain embodiment the system includes an electric motor. In a certain embodiment, the means for processing the first function into the second function comprises application of a transform T , such that $F_2(n) = T F_1(n)$, where F_2 is the second function; F_1 is the first function; and n is an ordered index number of an n th discrete sample, where $n \in \{0, 1, 2, \dots, \infty\}$; and wherein T comprises $(ke^{-2\pi i \Omega (n-d)} - Z)$, where k is a constant; e is an exponential; i is the imaginary number $\sqrt{-1}$; Ω is a frequency in cycles per sample interval; Z is a constant; and d is a delay constant.

[0010] In a certain embodiment, an engine control system includes a processing module that couples to an engine, the processing module configured to receive a first function comprising a user-specified power output of the engine over a time duration, and to process the first function into a second function comprising a directive power output of the engine over the time duration. The second function has at least one region of equal or

increased engine power output and at least one region of decreased engine power output, relative to the user-specified engine power output, such that, if the engine outputs power equal to the directive power output of the engine over the time duration, the engine consumes less fuel than the engine would have consumed if the engine outputted power equal to the user-specified power output of the engine over the time duration. The system includes providing the second function to an engine control module, such that the engine outputs power according to the directive power output of the engine over the time duration.

[0011] In a certain embodiment, the system includes an information module configured to inform a user of a possibility or achievement of fuel saving by the engine if the engine outputs power according to the directive power output of the engine. In a certain embodiment, the system includes an override switch configured to allow a user to select an override of the fuel savings. In a certain embodiment, the system includes the aspect that the user-specified power output of the engine is based on a cruise-control setting by a user. In a certain embodiment, the system includes the aspect that the second function is processed for smoothness. In a certain embodiment, the system includes a generator that supplements an output of the engine. In a certain embodiment, the generator comprises an electrical generator. In a certain embodiment, the generator comprises a motor. In a certain embodiment, the processing the first function into the second function includes application of a transform T , such that $F2(n) = T F1(n)$, where $F2$ is the second function; $F1$ is the first function; and n is an ordered index number of an n th discrete sample, where $n \in \{0, 1, 2, \dots, \infty\}$; and wherein T comprises $(ke^{-2\pi i \Omega (n-d)} - Z)$, where k is a constant; e is an exponential; i is the imaginary number $\sqrt{-1}$; Ω is a frequency in cycles per sample interval; Z is a constant; and d is a delay constant.

[0012] In a certain embodiment, a method is provided for conserving fuel used by an engine. The method includes receiving as an input to an engine power module a first function comprising a user-specified power output of an engine over a time duration. The method includes using a computer-executable instruction to process the first function into a second function comprising a directive power output of the engine over the time duration. The second function has at least one region of equal or increased engine power output relative to the user-specified engine power output, and the second function also has at least one region of decreased engine power output relative to the user-specified engine

power output, so that, if the engine outputs power equal to the directive power output of the engine over the time duration, the engine consumes less fuel than the engine would have consumed if the engine outputted power equal to the user-specified power output of the engine over the time duration. The method includes outputting, to an engine control module, the second function, such that the engine outputs power according to the directive power output of the engine over the time duration.

[0013] In a certain embodiment, an engine control system includes a processing module that couples to an engine, the processing module configured to receive a first function comprising a user-specified power output of the engine over a time duration, and uses a computer-executable instruction to process the first function into a second function comprising a directive power output of the engine over the time duration. The second function has at least one region of equal or increased engine power output and at least one region of decreased engine power output, relative to the user-specified engine power output, such that, if the engine outputs power equal to the directive power output of the engine over the time duration, the engine consumes less fuel than the engine would have consumed if the engine outputted power equal to the user-specified power output of the engine over the time duration. The system includes providing the second function to an engine control module, such that the engine outputs power according to the directive power output of the engine over the time duration.

[0014] In the following description, reference is made to the accompanying attachment that forms a part thereof, and in which are shown by way of illustration specific embodiments in which the inventions may be practiced. It is to be understood that other embodiments may be utilized and changes may be made without departing from the scope of the present inventions.

Brief Description of Drawings

[0015] The inventions, both to their organization and manner of operation, may be further understood by reference to the drawings that include Figures 1 through 7B taken in connection with the following descriptions:

[0016] Figure 1A is a schematic illustration of a certain embodiment;

[0017] Figure 1B is a schematic illustration of a certain embodiment;

[0018] Figure 2 is a graph that is useful for describing certain embodiments including efficiency against engine speed;

[0019] Figure 3 is a block diagram useful for describing certain embodiments;

[0020] Figure 4A is a graph that is useful for describing certain embodiments;

[0021] Figure 4B is a graph that is useful for describing certain embodiments;

[0022] Figure 5 is a graph that is useful for describing certain embodiments including the application of a directive power output over time in comparison to a user-supplied input;

[0023] Figure 6A is a graph that is useful for describing certain embodiments including application of a directive power output over time in comparison to a user-supplied input;

[0024] Figure 6B is a graph that is useful for describing certain embodiments including application of a directive power output over time in comparison to a user-supplied input;

[0025] Figure 7A is a graph that is useful for describing certain embodiments including application of a directive power output over time in comparison to a user-supplied input; and

[0026] Figure 7B is a graph that is useful for describing certain embodiments including application of a directive power output over time in comparison to a user-supplied input.

Detailed Description of the Invention

[0027] The following description of illustrative non-limiting embodiments discloses specific configurations and components. However, the embodiments are merely examples of the present inventions, and thus, the specific features described below are merely used to describe such embodiments to provide an overall understanding of the inventions. One skilled in the art readily recognizes that the present inventions are not limited to the specific embodiments described below. Furthermore, certain descriptions of various configurations and components of the present inventions that are known to one skilled in the art are omitted for the sake of clarity and brevity. Further, while the term

“embodiment” may be used to describe certain aspects of the inventions, the term “embodiment” should not be construed to mean that those aspects discussed apply merely to that embodiment, but that all aspects or some aspects of the disclosed inventions may apply to all embodiments, or some embodiments.

[0028] Figure 1A is a block diagram of a certain embodiment of the present inventions including internal combustion engine system 10. In certain embodiments the system 10 may include both a hybrid-electrical portion and an internal combustion engine portion. The system 10 is configured for low fuel consumption and emissions. As shown in the figure, internal combustion engine 12 is powered by a fuel supply 14. While an electric motor generator (EMG) 16 is shown as coupled to engine 12, certain embodiments do not require EMG 16, and in those embodiments engine 12 is coupled to CVT or multispeed transmission 24. In certain embodiments, electric motors such as EMG 16 may be coupled into a drive system such as system 10 in different ways. For example, electric motors may be directly coupled to wheels 34 in accordance with certain embodiments.

[0029] In certain embodiments, engine 12 is coupled to at least one of EMG 16 and CVT / multispeed transmission 24 with either a clutch 18 or other coupling device, such as a torque converter. EMG 16 is powered by battery 20 (that may include a capacitor), and battery energy is controlled with E/MG controller 22. E/MG controller 22 controls the extent of power output torque T_m generated by EMG 16. At certain points along a torque T_e power curve (for instance, one of the power curves shown in Figure 2 as C1- C1, C2 – C2, or C3 – C3), E/MG controller 22 controls EMG 16, as instructed by control computer 36 via E/MG torque signal 42, to either produce additional electrical motor torque T_m , to reduce a total amount of electrical motor torque T_m , or to stop producing electrical motor torque T_m .

[0030] In certain embodiments, control computer 36 comprises a processing module, and as such may be implemented in either of software means or hardware means. For example, control computer 36 may be a programmable logic controller, a computer comprised of chips and circuits along with firmware and/or software, or an integrated chip containing software instructions for performing the processing described herein. In either example the control computer 36 is in communicative connection with internal combustion engine system 10, as one of skill in the art would comprehend and as described herein.

[0031] In certain embodiments, EMG 16 may be coupled to a continuously variable transmission (CVT) or multispeed transmission 24 which receives, at its input, at least one of engine 12 torque (T_e) and electric motor 16 torque (T_m) 26. CVT 24 turns a drive shaft 28. Drive shaft 28 is coupled to final drive 30 which turns axle 32 and which is coupled to wheels 34. Thus, at least one of T_e and T_m causes the wheels 34 to turn. Control computer 36 sets control parameters and monitors the overall operation of the system 10, including control of fuel 14 to the engine 12 via engine throttle control signal 38. While “throttle” typically indicates a carburetor device, one of skill in the art would understand that any controlled input could be used to deliver fuel 14 to engine 12, such as fuel injection, microspray, and/or ultrasonic atomizing. In certain embodiments, fuel 14 may be any type of combustible fuel including a liquid such as gasoline, gasohol, bio-fuel, or a compressed gas, such as hydrogen, propane, or methane.

[0032] Control parameters within control of control computer 36 may include, in addition to engine throttle control signal 38, shift of ratio rate (rate of change ratio) 40 for the CVT or multispeed transmission 24, and E/MG torque parameters 42 for E/MG controller 22. Operational characteristics that may be monitored include ratio 44 of the CVT or multispeed transmission 24, engine speed (S_e) 46, depth of discharge (DOD) 48 for the battery, as provided by battery monitoring system 50, vehicle speed 52, and driver input 54 (e.g., accelerator/brake pedal motion). Battery monitoring system 50 may be a computer, or may be controlled by a programmable logic controller (PLC), or other monitoring/control device as may be selected by one of skill in the art.

[0033] In certain embodiments, CVT 24 may smooth engine oscillations. For example, when engine 12 has variations in RPMs that are significant enough to be felt by a driver, CVT 24 may change its shift of ratio rate to compensate. That is, the CVT 24 may change its shift of ratio rate so that the variation in engine RPM speed is either not felt or is felt less by a driver.

[0034] In certain embodiments, driver input 54 includes at least a first function that comprises a directive power torque T_e output over a time duration. Driver input 54 need not be provided by a human driver, but nonetheless may be an input such as a depressed acceleration pedal or brake pedal, or it may be an input from a cruise control module, or a pre-determined input, or a patterned input that may be based upon a recent history of the internal combustion engine system 10, or an expected usage pattern. The input 54 is

provided to control computer 36. Engine torque (T_e) 56 is measured at control computer 36 via engine torque feedback loop 55. Engine torque T_e is a function of force applied to a crankshaft of engine 12 and as felt at clutch or coupling device 18.

[0035] In certain embodiments, control computer 36 is configured to have access to a memory (either internal or external to control computer 36) that includes knowledge of engine 12 parameters. Engine 12 parameters includes at least knowledge of expected torque T_e for engine 12 including knowledge of T_e along a power curve and selected or selectable zones of efficiency within the power curve. Engine 12 parameters may include further knowledge, such as cubic inches of chamber space available for ignition of fuel 14, type of required or suggested fuel 14, shape of the ignition chambers, compression ratios of ignition chambers, friction coefficients, and optimum thermal dynamics.

[0036] Figure 1B illustrates engine 12, EMG 16, battery 20 and CVT / multispeed transmission 24 according to some embodiments. EMG 16 may comprise one or more alternators and one or more electric motors. Battery 20 may comprise one or more batteries and one or more capacitors. The alternator of EMG 16 may convert the mechanical energy produced by engine 12 into electrical energy. This electrical energy may charge the battery and/or the capacitor. The capacitor can be useful because the battery may not always be able to charge sufficiently fast enough, especially when a lot of electrical energy (e.g., current) is produced. In such a case, the electrical energy may be lost, thus causing general efficiency to decrease and also causing the loss of energy which could have been applied to supplementing fuel energy from fuel consumption. According to certain embodiments, having one or more capacitors may mitigate this problem. The capacitor may charge and discharge very quickly compared to the battery. The charge from the capacitor may be used later to charge the battery or may be used to power an electric motor (e.g., EMG 16) which may supplement the engine's output. For example, the capacitor may be about one to two Farads. Multiple capacitors may be used. In some embodiments, the battery may be in parallel to the capacitor. In some embodiments, the battery may be in series with the capacitor. The stored electrical energy from battery 20 may be applied to the electric motor.

[0037] Figure 2 is a graph illustrating maximum efficiency for various internal combustion engines along power curves C1 - C1, C2 - C2, and C3 - C3. Efficiency is shown along the y axis, and speed is shown along the x axis. Each of power curves C1 -

C1, C2 - C2, and C3 - C3 are examples of different internal combustion engines and their relative efficiencies in view of torque and revolving speed S_e . Each internal combustion engine has an initial speed and torque output that begins at zero. Speed S_e increases as a result of the amount of force (T_e) applied to a crankshaft. The amount of force (T_e) begins at a low point, hits a peak, and then descends across a spectrum of speed. That is, at a speed S_e just above zero and progressing towards a faster revolving engine speed, force T_e initially approaches and then reaches maximum efficiency as shown by points A1, A2, and A3 for respective power curves, C1 - C1, C2 - C2, and C3 - C3. Prior to reaching points A1, A2, and A3, the internal combustion engine reaches a zone of efficiency at points A1_i, A2_i, and A3_i, respectively.

[0038] A zone of efficiency for many vehicles with internal combustion engines includes a revolving speed S_e that equates to a vehicle speed of about 45 to 60 miles per hour. As one of skill in the art would understand, vehicle speed in terms of miles per hour depends upon many factors in addition to torque T_e and revolving speed S_e , such as weight of the vehicle and load (if any) in addition to vehicle weight, aerodynamics, transmission ratio, and incline or decline of path traveled.

[0039] Individual zones of efficiency A1_i - A1_{ii}, A2_i - A2_{ii}, and A3_i - A3_{ii} reach a maximum point of efficiency A1, A2, and A3, respectively, and then as revolving speed S_e continues to increase, overall efficiency at points A1_{ii}, A2_{ii}, and A3_{ii}, has reached a point of diminishing returns - that is, any increase in fuel 14 provided to engine 12 past points A1_{ii}, A2_{ii}, and A3_{ii} results in less and less torque T_e as far as gains in revolutions per minute, or speed S_e is concerned. There may be multiple zones of efficiency for individual power curves, for example, a preferred zone, a secondary zone, and a tertiary zone. For purposes of clarity, Figure 2 illustrates a preferred zone of efficiency, for example, A1_i - A1_{ii}, as an aspect of certain embodiments.

[0040] According to some embodiments, efficiency may be represented as:

$$\text{Efficiency} = \frac{\text{Output}}{\text{Input}} = \frac{\text{Work}}{\text{Work} + \text{Energy}_{\text{Loss}}}$$

[0041] Thus, efficiency may be determined in terms of the ratio between the amount of energy going to work and the amount of energy going to work plus any energy that is lost. Energy loss may come from a variety of sources, for example, heat loss and loss of

electrical energy because of inefficiencies with battery charging. In certain embodiments, efficiency can be improved by reducing the energy loss.

[0042] As noted previously, input 54 shown in Figure 1A includes a user-specified power output as a first function for engine 12 over a time duration. By way of example, a user-specified power output may be provided when a user depresses an accelerator pedal or engages a cruise control module. Control computer 36 takes the first function and processes the first function into a second function. The second function comprises a directive power output T_e of engine 12 for a time duration and the second function may be delivered to engine 12 via engine throttle signal 38. The second function may include both a region of equal or increased power output and a region of decreased power output in relation to the first function. That is, the second function represents a modified version of the first function after having undergone further processing.

[0043] For example, in a certain embodiment, the second function is derived from the first function after having been processed with an algorithm, for instance:

[0044] $P_d = (F_{2reg1} + F_{2reg2} \approx F_1)$, where

[0045] P_d = directive power output;

[0046] F_{2reg1} = a region of equal or increased engine power output relative to a user-specified power output F_1 ($F_{2reg1} \geq F_1$); and

[0047] F_{2reg2} = a region of decreased engine power output relative to the user-specified power output F_1 ($F_{2reg2} < F_1$).

[0048] In a certain embodiment, a driver depresses a gas pedal. The depressed gas pedal provides an input 54 to control computer 36. (Input 54 may be another input, such as a cruise control input.) Control computer 36 is aware of engine speed S_e 46 and also has access to a memory (not shown in Figure 1A) that is either internal or external to computer 36. The memory includes at least knowledge of expected torque T_e for engine 12 including knowledge of T_e along a power curve and selected or selectable zones of efficiency within the power curve. For example, in certain embodiments, the memory includes knowledge of power curve $C1 - C1$ and a preferred zone of efficiency $A1_i -$

A1_{ii}. Control computer 36 also receives as an input the feedback loop signal 55 for engine torque T_e .

[0049] With knowledge of the information of the engine's (element 12's) power curve C1 – C1, the preferred zone of efficiency A1_i – A1_{ii}, and with the engine torque T_e signal 56, control computer 36 is configured to process driver input 54, and to produce a second function from driver input 54. The second function includes a region where engine power T_e may be equal or increased when revolving speed S_e is presently less than point A1_{ii} on power curve C1 – C1. The second function also includes a region of decreased power where engine revolving speed S_e is presently greater than point A1_{ii} on power curve C1 – C1. During a region of equal or increased power, control computer 36 may instruct engine 12 using engine throttle signal 38 to provide additional quantities of fuel 14 to an internal combustion chamber. During a region of decreased power, control computer 36 may instruct engine 12 using engine throttle signal 38 to lessen quantities of fuel 14 to an internal combustion chamber.

[0050] In certain embodiments, control computer 36 is configured to oscillate fuel delivery instructions to engine 12 multiple times over a time duration. For example, the control computer 36 may swing back and forth between instructing engine 12 to provide additional quantities of fuel 14, and instructing engine 12 to lessen quantities of fuel 14 to an internal combustion chamber. During such fuel oscillation, when the engine torque T_e and engine speed S_e is below point A1_{ii}, and the driver input (or other signal such as a cruise control input) 54 indicates, for example, a depressed acceleration pedal, the instruction to provide additional quantities of fuel 14 will occur over a greater duration during a specified time duration than will the instruction to lessen quantities of fuel 14.

[0051] In some embodiments, the overall result during such fuel oscillation is that less fuel is consumed during a time duration than if the engine either had proceeded with a wide-open throttle, or had proceeded with only continuing periods of additional and unrestricted fuel consumption. In some embodiments, the overall result during such fuel oscillation is that less fuel is consumed during a time duration than in a drive system without system 10. In certain embodiments, oscillation of the fuel delivery as described above is imperceptible to a driver because the fuel quantities can be very finely controlled by the control computer 36, can be smoothed, and can be compensated for by an output from an additional motor, or by varying the ratio on a CVT / multispeed transmission 24.

In certain embodiments, oscillation of the fuel delivery as described above is imperceptible to a driver because the instruction to lessen, dampen, or cut fuel quantities occurs during a short time period, for example, 50 milliseconds, while the instruction to provide additional quantities of fuel occurs during a longer time period, for example, 250 milliseconds. In certain embodiments, oscillation of the fuel delivery as described above includes a ramp-up period of about 5 – 7 seconds while the engine 12 is coming up to speed, followed by oscillations where the instruction to provide additional quantities of fuel occurs during a period of about 1 - 2 seconds, followed by the instruction to lessen, dampen, or cut fuel quantities that occurs during a time period of about 3 - 4 seconds, in reiterative fashion.

[0052] In certain embodiments, the above-noted fuel oscillation is stopped during periods of ‘hard’ acceleration. For example, when a user depresses a gas pedal beyond a certain threshold and/or at a speed that exceeds a certain threshold, the system may in that case cease to apply the second function so that a user may apply as much throttle with as much corresponding torque or power as is needed or desired.

[0053] In certain embodiments, when the engine torque T_e and engine speed S_e is above point $A1_{ii}$ and the driver input signal (or other input such as a cruise control signal) 54 indicates a depressed acceleration pedal (or other condition or pattern), the instruction to provide additional quantities of fuel 14 will occur over a lesser duration during a specified time duration than the instruction to lessen quantities of fuel 14. In some embodiments, the overall result during such fuel oscillation is that less fuel is consumed during a time duration than if the engine either had proceeded with a wide-open throttle, or had proceeded with only continuing periods of additional and unrestricted fuel consumption. In some embodiments, the overall result during such fuel oscillation is that less fuel is consumed during a time duration than in a drive system without system 10.

[0054] In certain embodiments, when the engine torque T_e and engine speed S_e is above point $A1_{ii}$, the internal combustion engine system 10 is configured to bring operation of the engine 12 back to within the zone of efficiency $A1_i - A1_{ii}$. That is, when engine torque T_e and engine speed S_e is above point $A1_{ii}$, and there fails to be a driver input signal (or other input signal such as a cruise control signal) 54 indicating a depressed acceleration pedal (or other condition or pattern indicating a required torque above point $A1_{ii}$), the instruction to provide additional quantities of fuel 14 will approximate a fuel

quantity for mere minimal operation of engine 12, and will occur over a lesser duration during a specified time duration than the instruction to lessen quantities of fuel 14.

[0055] In certain embodiments, EMG 16 is configured to be instructed by control computer 36 via E/MG torque signal 42 to supplement the torque T_e of engine 12 with electrical motor torque T_m . For example, when torque T_e and Speed S_e for engine 12 has reached point $A1_{ii}$ in Figure 2, and control computer 36 receives driver input 54 (which may be from the driver depressing the gas pedal, from a cruise control unit, or may be derived from a usage history of the internal combustion engine system 10) indicating greater speed is desired, control computer is configured to instruct E/MG controller 22 via E/MG torque signal 42 to increase the amount of electrical motor torque T_m such that the engine 12 never leaves zone of efficiency $A1_i - A1_{ii}$, while still providing a combined electrical motor torque T_m and engine torque T_e that exceeds that of point $A1_{ii}$. In this situation, the EMG 16 and engine 12 may be able to contribute to the movement of the vehicle independently.

[0056] In certain embodiments, EMG 16 is configured to be instructed by control computer 36 via E/MG torque signal 42 to provide a majority of torque power to CVT or multispeed transmission 24. For example, when torque T_e and speed S_e of engine 12 is either below point $A1_i$ or above point $A1_{ii}$ on power curve $C1 - C1$, control computer 36 may instruct E/MG controller 22 through E/MG control signal 42 to have EMG 16 produce some, most, or approximately all of the torque energy felt at CVT / multispeed transmission 24. Then, once engine 12 is operating within zone of efficiency $A1_i - A1_{ii}$, control computer 36 may instruct E/MG 22 via E/MG control signal 42 to lessen the amount of T_m torque produced, to cease producing T_m torque, and/or to convert some of T_e torque to electrical charging energy to charge battery 20 (battery 20 may include a capacitor).

[0057] In certain embodiments, battery 20 is at least partially configured to be charged from an alternator powered by engine 12. In certain embodiments, battery 20 is configured to be charged by electric motor generator 16 converting some or all of torque energy T_e (or engine output in general) to electrical charging energy. For instance, when battery monitoring system 50 notes a need to charge battery 20, depth of discharge (DOD) signal 48 notifies control computer 36. Control computer 36 notes the need to charge battery 20, and during opportune moments (such as when a combined torque

output of both T_e and T_m is not necessary) E/MG controller 22 instructs electric motor generator 16 to convert a portion of T_e from engine 12 to electrical charging energy. The electrical charging energy is then fed to battery / capacitor 20 for charging. Similarly, a certain embodiment provides for recouping energy created by braking or other deceleration to charge the battery / capacitor 20.

[0058] In certain embodiments, control computer 36 is configured to process the first function 54 (that is, the driver input, cruise control input, or other input 54) approximately contemporaneously with reception of the first function at control computer 36. In certain embodiments, control computer 36 is configured to process the first function substantially extemporaneously based on a history of the first function over time. For example, control computer 36 may take an instantaneous (e.g., one second) snapshot of first function / driver input 54. During that instant, the driver of the vehicle being run by internal combustion engine system 10 may have just begun accelerating on a freeway on-ramp to enable a merge into on-coming traffic. This may be aided by various sensors in the vehicle such as acceleration or yaw sensors.

[0059] Because the snapshot indicates that the driver desires acceleration, control computer 36 may process the first function / driver input signal 54 and then extemporaneously apply the second function (discussed above) derived from the first function (discussed above) for a certain duration of time, for example, for five seconds, based upon the one second reception of the first function. During that five seconds, control computer 36 may control and manipulate the internal combustion engine system 10 in the manner discussed in relation to Figures 1 and 2, above, to achieve a savings in fuel 14.

[0060] In certain embodiments, a feedback loop is provided that is configured to provide a display of information of possible fuel savings and/or the achievement of fuel savings. In certain embodiments, a user is provided with a kill switch (for instance, switch 311 described in relation to Figure 3) that is configured to withhold the second function from being applied to the engine 12, thereby allowing engine 12 to reach a wide-open throttle across any engine revolving speed S_e . In certain embodiments as described above, a hard acceleration request from a user may also allow engine 12 to reach a wide-open throttle by withholding the second function.

[0061] Efficiency is examined herein as a function of power. Although power is discussed, other parameters could be used for implementation of the second function to produce a directive power output. The following non-exclusive list provides examples of such parameters: engine power output, torque, horsepower, proportional air-fuel mixture, rate of fuel injection, engine timing, throttle setting, the speed or velocity of a fuel pump, the rate of exhaust, and alterations in the ignition of the fuel, among others.

[0062] Those skilled in the art will readily appreciate that the control methods, policies and/or algorithms of certain embodiments may be implemented on any conventional computer system under processor control using conventional programming techniques in any of hardware, software, or firmware. Further, those skilled in the art will readily appreciate that the control methods, policies and/or algorithms of certain embodiments may be implemented on any internal combustion engine, jet engine, motor boat engine, diesel engine, hybrid combustion-electric engine, and the like.

[0063] Figure 3 is a block diagram useful for describing certain embodiments, including a method of conserving fuel for an engine. Block 301 represents providing a first function comprising a user-specified output of an engine over a time period to an engine power module, for example, the first function as discussed in relation to Figure 2. Block 303 represents processing (or extrapolating) the first function into a second function comprising a directive power output over a time duration. In certain embodiments, the second function may comprise at least one region of equal or increased engine power output relative to the user-specified engine power output, and also at least one region of decreased engine power output relative to the user-specified engine power output. An example of a second function is that as discussed in relation to Figure 2. As shown in that figure, the second function may comprise a directive power output T_e of engine 12 for a time duration and the second function may be delivered to engine 12 via engine throttle signal 38. The second function may include a region of equal or increased power output and a region of decreased power output in relation to the first function. That is, in certain embodiments the second function represents a modified version (or extrapolation) of the first function after having undergone further processing.

[0064] Block 305 illustrates the inclusion, in certain embodiments, of a kill switch 311, or a user-provided input 311, that overrides potential fuel savings and allows up to a maximum torque such as that provided by a wide-open throttle. In a certain embodiment

comprising the features of block 305, a display may provide information regarding present fuel savings (or the possibility of fuel savings). A user may determine that at that particular moment the engine needs to provide maximum output (e.g., power, torque) and/or speed, and therefore engages switch 311. In certain embodiments, switch 311 may be a threshold on an accelerator pedal, whereupon if the user depresses the pedal past the threshold in terms of either how quick the pedal is depressed and/or how far the pedal is depressed, the switch is engaged. Switch 311 provides an input to a processing module, such as processing module 36 shown in Figure 1A, and when the user has determined to override any fuel savings or potential fuel savings, processing module 36 allows the engine to be operated by the user in an unconstrained fashion, that is, to be used for possibly maximum output and/or speed. In other words, the operator is allowed to operate the engine without the directive power output of the second function being applied.

[0065] In certain embodiments, the function represented by switch 311 is a ‘true’ off switch. That is, once the switch 311 is engaged, the operator is allowed to operate the engine without the directive power output of the second function being applied until the operator re-engages the switch 311. In certain embodiments, once the switch 311 is engaged by an operator (and not re-engaged during a course of driving by the operator), the switch is re-engaged by the vehicle automatically upon the engine 12 being turned off and then back on. In certain embodiments, when a user-provided input indicates a high demand for vehicle speed (such as by a user ‘flooring’ a gas pedal), the switch 311 causes a directive engine power output (for instance, that output illustrated by the dashed line in Figure 5) to cease oscillations above and below the user-specified engine power output (for instance, that output illustrated by the solid line in Figure 5). In certain embodiments, switch 311 is an engagement switch, i.e., when a user turns the vehicle on, the second function is not automatically implemented but is implemented once a user engages switch 311.

[0066] Block 307 represents a certain embodiment, where a user may be provided with fuel savings information, and based on that information the user may decide to not engage kill switch 311 while nonetheless engaging an acceleration pedal, thereby informing, for instance, processing module 36 that additional torque output is desired while either maintaining or increasing a fuel savings. In such an instance, processing module 36 may

instruct an electric torque generator (such as electric motor generator 16 shown in Figure 1A) to supplement the torque generated by the engine.

[0067] Block 309 represents at least a couple of scenarios. First, in a certain embodiment, the processing module 36 may determine that the user is desiring less torque and/or speed, as provided by the first input discussed in relation to Figure 2. In that instance, processing module 36 may lessen fuel to the engine to achieve a fuel savings. In another scenario for a certain embodiment represented by block 309, a user may provide an input to processing module 36 by means of a cruise control, or by simply maintaining a present speed for a certain period (such as five seconds), and based on that input the processing module 36 may determine that an electric torque generator (such as electric motor generator 16) may increase its output to maintain a consistent torque or speed as experienced by a user, while still lessening fuel to the engine to achieve a fuel savings. Finally, in a certain embodiment represented by block 309, the processing module 36 may determine that a user-specified increase, such as a depressed accelerator pedal, falls within a range whereby the electric generator is capable of increasing total torque output while diminishing the torque output of the engine by lessening fuel, thereby achieving a fuel savings.

[0068] Figure 4A is a graph that illustrates some embodiments including the use of torque / output power / acceleration as a determinant of efficiency in view of a period of acceleration over time. As shown in the figure, prior to point 401 the directive engine power output (shown by the dashed line) oscillates both above and below the user-specified engine power output (shown by the solid line). Between points 401 and 404 lies time frame 405. During time frame 405 the directive power output comprises a region of both increased and decreased engine power output relative to the user-specified engine power output. For example, time frame 406 comprises a directed engine power output that is, substantially, greater than the user-specified engine power output.

[0069] Further, the time between points 401 and 402 reflects a region of decreased directive engine power output relative to the user-specified engine power output. Point 403 reflects a peak oscillation of the directive engine power output. Area 411 represents a region where, based on the user accelerating beyond a particular threshold, the system may allow a user to operate the engine without the directive power output of the second function being applied, for instance, in cases of urgency where a user needs a

substantially wide-open throttle. In certain embodiments under these circumstances, a user depresses a gas pedal beyond a threshold. By going beyond the threshold (either a physical threshold, such as past a physical point, or a virtual threshold, such as beyond a particular speed), the system allows the operator to use the vehicle without the directive power output of the second function being applied.

[0070] Mathematics may be used to describe certain embodiments including the situation where a user is either constantly accelerating a vehicle or maintaining a steady velocity. Consider the user-specified input to be a first function, F_1 . Further consider that n as an index for the number of a particular discrete sample in an integer series (e.g., 0, 1, 2, ... n) equals a number, and that T is a transform to apply to the first function to arrive at a second function, F_2 , that comprises a directive power output. In certain embodiments F_2 may comprise the directive power output illustrated by the dotted lines in any of Figures 4A, 4B, 5, 6A, 6B, 7A, or 7B. This may be shown as expressed below.

$$F_2(n) = T F_1(n)$$

[0071] Further consider that in some embodiments the transform T comprises $(ke^{-2\pi i \Omega (n-d)} - Z)$, where T may be equal to a constant k times an exponential function, e , where e is an inverse of a natural log that, along with its exponent, makes the second function oscillate. Additional variables shown include the imaginary number i , and omega (Ω) as a representation of frequency in cycles per sample interval. The variable d is a constant and is an integer that may include zero (e.g., 0, 1, 2, ... d). If d is a positive integer, it provides a true time delay. If d is negative, it provides a non-causal product because $F_2(n)$ depends on future samples (e.g., $n + 1$ or $n + 2$). The variable Z is a constant that provides an offset for the final directive power output. When Z is positive, the offset moves 'down' with respect to efficiency (or other parameter along the y axis). When Z is negative, the offset moves 'up.' Note that Z could be zero. Note that in some embodiments d is optionally implemented as a delay, and that the offset provided by Z may be used to provide, on average, less power output than the user-specified function, F_1 . In some embodiments, $d = 0$.

[0072] The graph of Figure 4A may also be explained mathematically for a certain embodiment comprising the situation where a user is constantly accelerating a vehicle. Consider that in some embodiments the first function comprises a straight line segment of

slope S representing constant acceleration. In some embodiments, slope S of the user-specified output over time is shown by the solid line in Figure 4A. This may be expressed as shown below.

$$F_1(n) = Sn$$

[0073] In view of some embodiments where a user is constantly accelerating a vehicle as described above, the derived second function may be expressed as provided below.

$$F_2(n) = TSn = (ke^{-2\pi i \Omega (n-d)} - Z) Sn$$

[0074] Note that the variable n may equal one or more distinct time periods $t_0 \dots t_n$ (shown on the graph of Figure 4A as Time 1 through Time 15). Also note that n is a discrete integer. In certain embodiments the above-featured processing algorithm may be used during any instance of acceleration or deceleration. Furthermore, note that while the y axis of the graph of Figure 4A (in addition to subsequent graphs as shown in later figures) represents power, the y axis may represent other quantities, such as fuel consumption, engine revolutions per minute, or velocity of the vehicle.

[0075] Figure 4B is a graph that illustrates some embodiments similar to Figure 4A. As shown in Figure 4B, the directive engine power output (shown by the dashed line) oscillates between being substantially equal to the user-specified function, and being below the user-specified engine power output (shown by the solid line).

[0076] The graphs of Figures 5, 6A, 6B, 7A, and/or 7B may be explained mathematically for certain embodiments implementing a cruise control or like device for producing substantially constant velocity. An algorithm for a cruise control device, as provided below, is similar to that algorithm described above, but comprises a constant C . Constant C represents, for example, a substantially constant input of the user-supplied function F_1 shown by the solid lines in Figures 5, 6A, 6B, 7A and 7B. In certain embodiments F_2 may comprise the directive power output illustrated by the dotted lines in Figures 5, 6A, 6B, 7A, and 7B. The first function in this embodiment may be described as shown below.

$$F_1(n) = C$$

[0077] In this embodiment, the derived second function may be expressed as shown below.

$$F_2(n) = T C = (k e^{-2\pi i \Omega (n-d)} - Z) C$$

[0078] In certain embodiments the above-featured processing algorithms may be used to extrapolate a particular predictive driving behavior. For instance, the transform T may be used to analyze ten discrete and equal time periods of a few hundred milliseconds each. A result of the transform may then be determined by a controller or a processor, and embodiments of the subject technology may then apply the second function, F_2 , for a certain period of time, for instance, five seconds, with a rolling window of continued application of the second function. That is, the above-noted transform may be repeatedly applied on a rolling basis until a known end event, such as a user applying a brake pedal, applying a switch, pressing the accelerator pedal past a physical threshold or past a speed threshold, or another event.

[0079] Figure 5 is a graph that illustrates some embodiments including the use of torque / output power / acceleration as a determinant of efficiency in view of a substantially steady velocity that is maintained (or anticipated to be maintained), for example, during application of a cruise control input as a first, user-supplied function. As shown in the figure, the directive engine power output (shown by the dashed line) oscillates both above and below the user-specified engine power output (shown by the solid line). At point in time 9, a user has provided a cruise control input that is intended to maintain the speed / velocity of the vehicle. After point 9 the directive power output comprises a region of both increased and decreased engine power output relative to the user-specified engine power output and includes oscillations equal to, above and below the user-supplied function.

[0080] The graph of Figure 5 after point 9 may also be explained mathematically for a certain embodiment as a function of power and time. For instance, assume that at point 9, a directive power function, F_d , applies to both power (p) and time (t). The controller 36 (from Figure 1A, for example) applies the directive power function F_d as a function of both (p) and (t), and extrapolates a projected directive power output over a certain time period. For example, assuming that each time period reflected in Figure 5 is a discrete moment, for example, 1 second, and that a representative power output is located at each

discrete moment in time, then $F_d(p1, t1) = F_d(100 \text{ watts}, 1 \text{ second})$, and $F_d(p2, t2) = F_d(150 \text{ watts}, 1 \text{ second})$, etc . . . through $F_d(p_n, t_n) . . .$, then the controller 36 in certain embodiments, extrapolates a future directive power output for a future time period, for example, 4 seconds. For instance, in certain embodiments, the controller 36 has measured the user-provided input as a first function, and based on a continuity of that input for a certain period (for example, 2 seconds) with a steady engine revolving speed and substantially constant velocity (for instance, as provided by a cruise control input), the controller 36 extrapolates that the velocity will be maintained for at least 1 cycle, which in the example shown in Figure 5 represents 4 seconds, or the time frame from time periods 9 to 13.

[0081] The extrapolation shown in Figure 5, as monitored and controlled by controller 36, continues past point 13 based on the fact that the user-provided input indicates, as viewed from a short, historical perspective (for example, a second) that the engine revolving speed and the vehicle velocity should continue in status quo fashion for a set future length of time. Although watts are described above, one of skill in the art would comprehend that other qualifiers could be used, such as power out divided by power in, or foot/lbs, or another measure of power.

[0082] In certain embodiments where the controller 36 receives a first function that comprising a user-specified power output of the engine 12 over time, the first function may be a cruise control setting for velocity that is derivable into a power output of the engine over time. Further, either of the first or second functions discussed above may be derived from either of a series of data points over time, or a single data point over time. If the function is derived from a single data point over time, it may be a constant data point, or it may be a data point that changes over time, for example, a cruise control may provide a single data point that remains constant or changes over time, or it may provide multiple data points that remain constant or change over time. The vehicle may experience varying loads due to variations in terrain or wind.

[0083] Figure 6A is a graph that illustrates some embodiments including the use of torque / output power / acceleration as a determinant of efficiency in view of a substantially steady velocity that is maintained (or anticipated to be maintained), for example, during application of a cruise control input as a first, user-supplied function. As shown in the figure, the directive engine power output (shown by the dashed line) oscillates between

being substantially equal to the user-specified function, and being below the user-specified engine power output (shown by the solid line). Figure 6A also reflects certain embodiments where the directive power output has been smoothed, for instance with a binomial, Savitzky-Golay, moving, or other averaging process or algorithm that may make it difficult or even impossible for a user to detect that the directive power output is oscillating. An example using the moving average would simply replace each data value along the time line of the directive engine power output with the average of neighboring values. To avoid an unintended shift in the data, the neighboring values should be averaged using the same methodology.

[0084] Figure 6B is a graph that illustrates some embodiments similar to Figure 6A. As shown in Figure 6B, the constant C of the user-supplied function F_1 is lower than the constant C as illustrated in Figure 6A. In certain embodiments, the momentum of a vehicle may be capitalized to maintain the vehicle at a desired velocity without having to utilize additional energy. This may be referred to as coasting. For example, the valleys of the directive engine power output may represent instances when the vehicle is coasting to save on fuel consumption and yet, maintain a steady velocity (e.g., from cruise control). Less fuel may be consumed because more time may be spent in a zone of efficiency for the engine. Furthermore, coasting may result in a reduced power input, which may translate into a decreased heat output of the engine resulting in a more efficient engine (e.g., less energy in the form of heat is lost). In such a case, air conditioning and other cooling requirements may be decreased or relaxed and may increase driver comfort. In certain embodiments, electrical energy from the electric motor may be applied to keep the vehicle at a desired velocity when the vehicle is consuming reduced fuel energy (e.g., during a valley of the directive engine power output).

[0085] Figure 7A is a graph that illustrates certain embodiments where the directive power output has been smoothed, for instance as described in relation to Figure 6A, but wherein the directive power output is instructed to oscillate between slightly above the user-specified function to below the user-specified function. Figure 7B is a graph that illustrates some embodiments similar to Figure 7A. As shown in Figure 7B, the constant C of the user-supplied function F_1 is lower than the constant C as illustrated in Figure 7A. For example, Figure 7B may illustrate an example where the vehicle may be traveling at a

desired steady velocity. In some embodiments, the engine speed may be operating below a zone of efficiency. The directive engine power output may be controlled such that the engine speed can be increased above what would be needed to achieve the desired velocity (e.g., during a peak of the directive engine power output) to reach the zone of efficiency. Then the excess energy generated can be stored in and/or used to charge battery 20 (including the capacitor). When the directive engine power output is modulated such that the power output is decreased (e.g., during a valley of the directive engine power output), electrical energy from the battery 20 may be used (e.g., through the electric motor) to maintain the desired velocity of the vehicle. The changes in engine speed may be perceptible to a user. According to certain embodiments, electrical energy may be used to dampen or balance the modulation of the directive engine power output such that the modulation is not as perceptible to a user via supplemental output from an electric motor. In certain embodiments, the modulation of the directive engine power output may represent a repetition of acceleration followed by coasting to maintain the desired steady velocity. In some embodiments, electrical energy from an electric motor may not be needed to achieve the desired velocity.

[0086] In some embodiments, the subject technology may be applicable to a vehicle traveling at low velocities (e.g., city driving speeds below about 35 miles per hour). In some embodiments, the subject technology may be applicable to a vehicle traveling at high velocities (e.g., highway driving speeds above about 35 miles per hour). In some embodiments, other energy (e.g., electrical energy from an electric motor) may be used to supplement fuel energy at either low or high velocities.

[0087] In certain embodiments, with respect to references to power and torque as used herein, power may be used instead of torque and vice versa. Those of skill in the art would understand that motors and/or engines may generate both torque and power as outputs. Thus, the reference to output, as used herein, may comprise torque and/or power. According to certain embodiments, the subject technology may be practiced with either torque as an output or power as an output, without departing from the scope of the present invention. In some embodiments, torque may refer to the force used to rotate an object (e.g., tendency of force to rotate an object about an axis, fulcrum, or pivot). In some embodiments, power may refer to the work per unit time (e.g., rate at which work is

performed, energy is transmitted, or the amount of energy needed or expended for a given unit of time).

[0088] Although the description above contains many specificities, these should not be construed as limiting the scope of the inventions but as merely providing illustrations of some of the presently preferred embodiments. Therefore, it will be appreciated that the scope of the present inventions fully encompasses other embodiments which may become obvious to those skilled in the art, and that the scope of the present inventions are accordingly to be limited by nothing other than the appended claims, in which reference to an element in the singular is not intended to mean "one and only one" unless explicitly so stated, but rather "one or more." All structural, chemical, and functional equivalents to the elements of the above-described preferred embodiment that are known to those of ordinary skill in the art are expressly incorporated herein by reference and are intended to be encompassed by the present claims. Moreover, it is not necessary for a device or method to address each and every problem sought to be solved by the inventions, for it to be encompassed by the present claims. Furthermore, no element, component, or method step in the present disclosure is intended to be dedicated to the public regardless of whether the element, component, or method step is explicitly recited in the claims. No claim element herein is to be construed under the provisions of 35 U.S.C. 112, sixth paragraph, unless the element is expressly recited using the phrase "means for."

[0089] It is understood that any specific order or hierarchy or steps in the processes disclosed herein are merely exemplary illustrations and approaches. Based upon design preferences, it is understood that any specific order or hierarchy of steps in the process may be re-arranged. Some of the steps may be performed simultaneously.

[0090] The previous description is provided to enable persons of ordinary skill in the art to practice the various aspects described herein. Various modifications to these aspects will be readily apparent to those skilled in the art, and the general principles defined herein may be applied to other aspects. Thus, the claims are not intended to be limited to the aspects shown herein, but are to be accorded the full scope consistent with the claim language. Headings and subheadings, if any, are used for convenience only and do not limit the inventions. All structural and functional equivalents to the elements of the various aspects described throughout the disclosure that are known or later come to be

known to those of ordinary skill in the art are intended to be encompassed by the inventions.

WHAT IS CLAIMED IS:

1. A method, of conserving fuel used by an engine, comprising:
 - receiving as an input to an engine power module a first function comprising a user-specified power output of an engine over a time duration;
 - processing the first function into a second function comprising a directive power output of the engine over the time duration;
 - wherein the second function has at least one region of equal or increased engine power output relative to the user-specified engine power output;
 - wherein the second function has at least one region of decreased engine power output relative to the user-specified engine power output;
 - wherein, if the engine outputs power equal to the directive power output of the engine over the time duration, the engine consumes less fuel than the engine would have consumed if the engine outputted power equal to the user-specified power output of the engine over the time duration; and
 - outputting, to an engine control module, the second function, such that the engine outputs power according to the directive power output of the engine over the time duration.
2. The method of claim 1, further comprising displaying to a user an indication of a possibility or achievement of fuel savings by the engine if the engine outputs power according to the directive power output of the engine.
3. The method of claim 2, further comprising providing an actuator that permits the user to override the fuel savings.
4. The method of claim 1, wherein the input to the engine power module comprises a cruise-control setting by a user.
5. The method of claim 1, wherein the user-specified power output of the engine is based on a cruise-control setting by a user.
6. The method of claim 1, further comprising supplementing an output of the engine with output generated by an electric motor while the engine outputs power according to the directive power output of the engine.
7. The method of claim 1, further comprising supplementing a power output of the engine with power from a motor different from the engine while the engine outputs power according to the directive power output of the engine.

8. The method of claim 7, wherein the motor comprises an electric motor.
9. The method of claim 1, further comprising processing the second function for smoothness.
10. The method of claim 1, wherein the processing of the first function into the second function comprises application of a transform T, such that $F_2(n) = T F_1(n)$, where
 F_2 is the second function;
 F_1 is the first function; and
 n is an ordered index number of an n th discrete sample, where
 $n \in \{0, 1, 2, \dots, \infty\}$; and
 wherein T comprises $(ke^{-2\pi i \Omega (n-d)} - Z)$, where
 k is a constant;
 e is an exponential;
 i is the imaginary number $\sqrt{-1}$;
 Ω is a frequency in cycles per sample interval;
 Z is a constant; and
 d is a delay constant.
11. An engine control system, comprising:
 means for receiving, as an input, a first function comprising a user-specified power output of an engine over a time duration;
 means for processing the first function into a second function comprising a directive power output of the engine over the time duration;
 wherein the second function has at least one region of equal or increased engine power output relative to the user-specified engine power output;
 wherein the second function has at least one region of decreased engine power output relative to the user-specified engine power output;
 wherein, if the engine outputs power equal to the directive power output of the engine over the time duration, the engine consumes less fuel than the engine would have consumed if the engine outputted power equal to the user-specified power output of the engine over the time duration; and
 means for outputting, to an engine control module, the second function, such that the engine outputs power according to the directive power output of the engine over the time duration.

12. The engine control system of claim 11, further comprising means for informing the user of a possibility or achievement of fuel saving by the engine if the engine outputs power according to the directive power output of the engine.

13. The engine control system of claim 11, further comprising means for supplementing an output of the engine with output generated by a motor different from the engine during outputting of the second function.

14. The engine control system of claim 13, wherein the motor comprises an electric motor.

15. The engine control system of claim 11, wherein the input comprises a cruise-control setting by a user.

16. The engine control system of claim 11, wherein the user-specified power output of the engine is based on a cruise-control setting by a user.

17. The engine control system of claim 11, further comprising means for outputting the second function for a duration of time greater than a duration of time that the input is input to the means for receiving.

18. The engine control system of claim 11, further comprising means for processing the second function for smoothness.

19. The engine control system of claim 11, wherein the means for processing the first function into the second function comprises application of a transform T, such that $F_2(n) = T F_1(n)$, where

F_2 is the second function;

F_1 is the first function; and

n is an ordered index number of an n th discrete sample, where

$n \in \{0, 1, 2, \dots, \infty\}$; and

wherein T comprises $(ke^{-2\pi i \Omega (n-d)} - Z)$, where

k is a constant;

e is an exponential;

i is the imaginary number $\sqrt{-1}$;

Ω is a frequency in cycles per sample interval;

Z is a constant; and

d is a delay constant.

20. An engine control system, comprising:

a processing module that couples to an engine, the processing module configured to:

receive a first function comprising a user-specified power output of the engine over a time duration;

process the first function into a second function comprising a directive power output of the engine over the time duration, wherein the second function has at least one region of equal or increased engine power output and at least one region of decreased engine power output, relative to the user-specified engine power output; and

wherein, if the engine outputs power equal to the directive power output of the engine over the time duration, the engine consumes less fuel than the engine would have consumed if the engine outputted power equal to the user-specified power output of the engine over the time duration; and

output the second function to an engine control module, such that the engine outputs power according to the directive power output of the engine over the time duration.

21. The engine control system of claim 20, further comprising an information module configured to inform a user of a possibility or achievement of fuel saving by the engine if the engine outputs power according to the directive power output of the engine.

22. The engine control system of claim 20, further comprising an override switch configured to allow a user to select an override of the fuel savings.

23. The engine control system of claim 20, further comprising a generator that supplements an output of the engine.

24. The engine control system of claim 23, wherein the generator comprises an electrical generator.

25. The engine control system of claim 20, wherein the user-specified power output of the engine is based on a cruise-control setting by a user.

26. The engine control system of claim 20, wherein the second function is processed for smoothness.

27. The engine control system of claim 20, wherein the processing of the first function into the second function comprises application of a transform T, such that $F_2(n) = T F_1(n)$, where

F_2 is the second function;

F_1 is the first function; and

n is an ordered index number of an n th discrete sample, where

$n \in \{0, 1, 2, \dots, \infty\}$; and

wherein T comprises $(ke^{-2\pi i \Omega (n-d)} - Z)$, where

k is a constant;

e is an exponential;

i is the imaginary number $\sqrt{-1}$;

Ω is a frequency in cycles per sample interval;

Z is a constant; and

d is a delay constant.

28. A method, of conserving fuel used by an engine, comprising:
 receiving as an input to an engine power module a first function comprising a user-specified power output of an engine over a time duration;
 using a computer-executable instruction, processing the first function into a second function comprising a directive power output of the engine over the time duration;

wherein the second function has at least one region of equal or increased engine power output relative to the user-specified engine power output;

wherein the second function has at least one region of decreased engine power output relative to the user-specified engine power output;

wherein, if the engine outputs power equal to the directive power output of the engine over the time duration, the engine consumes less fuel than the engine would have consumed if the engine outputted power equal to the user-specified power output of the engine over the time duration; and

outputting, to an engine control module, the second function, such that the engine outputs power according to the directive power output of the engine over the time duration.

29. An engine control system, comprising:

a processing module that couples to an engine, the processing module configured to:

receive a first function comprising a user-specified power output of the engine over a time duration;

using a computer-executable instruction, process the first function into a second function comprising a directive power output of the engine over the time duration, wherein the second function has at least one region of equal or increased engine power output and at least one region of decreased engine power output, relative to the user-specified engine power output; and

wherein, if the engine outputs power equal to the directive power output of the engine over the time duration, the engine consumes less fuel than the engine would have consumed if the engine outputted power equal to the user-specified power output of the engine over the time duration; and

output the second function to an engine control module, such that the engine outputs power according to the directive power output of the engine over the time duration.

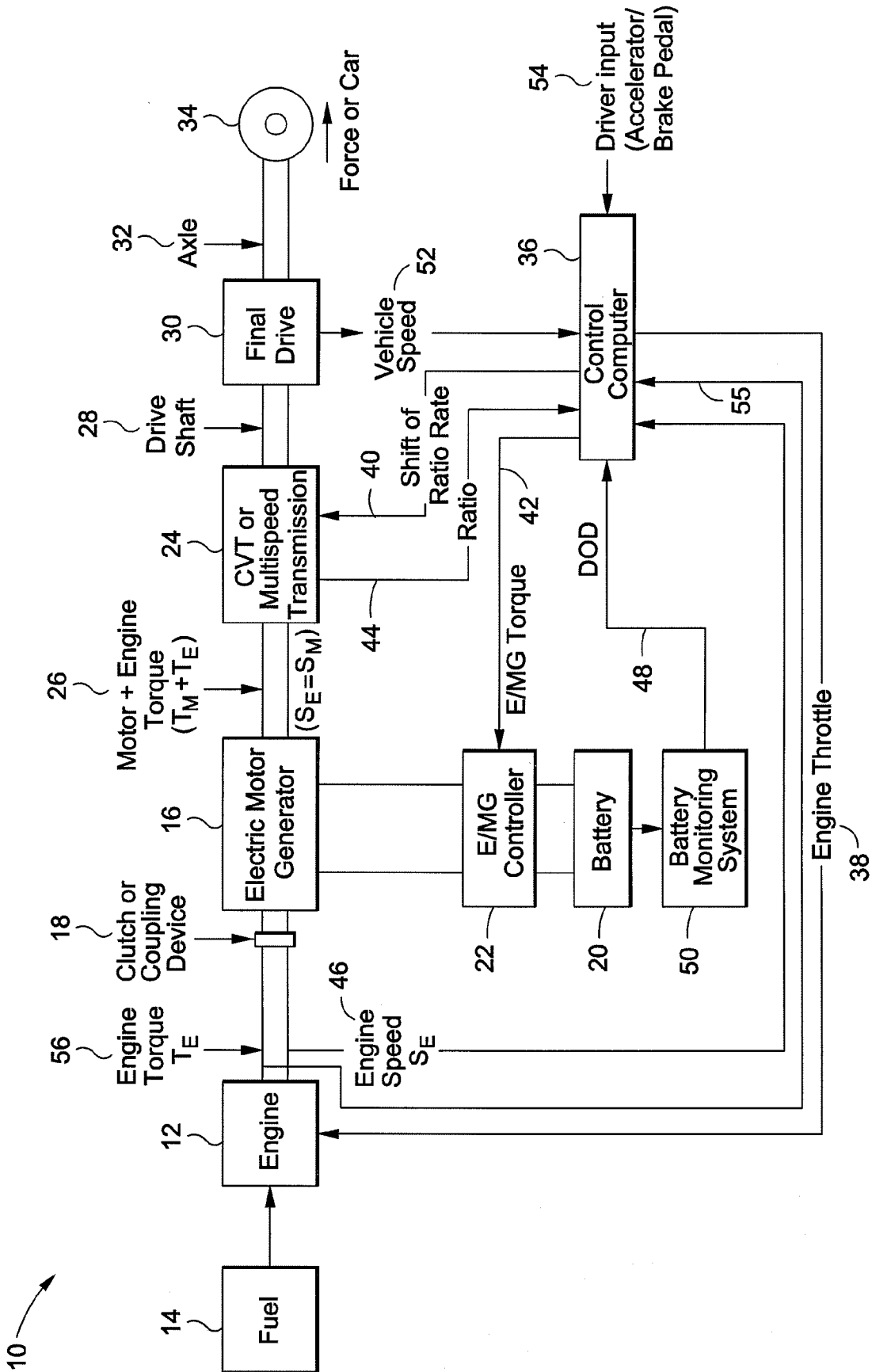

FIG. 1A

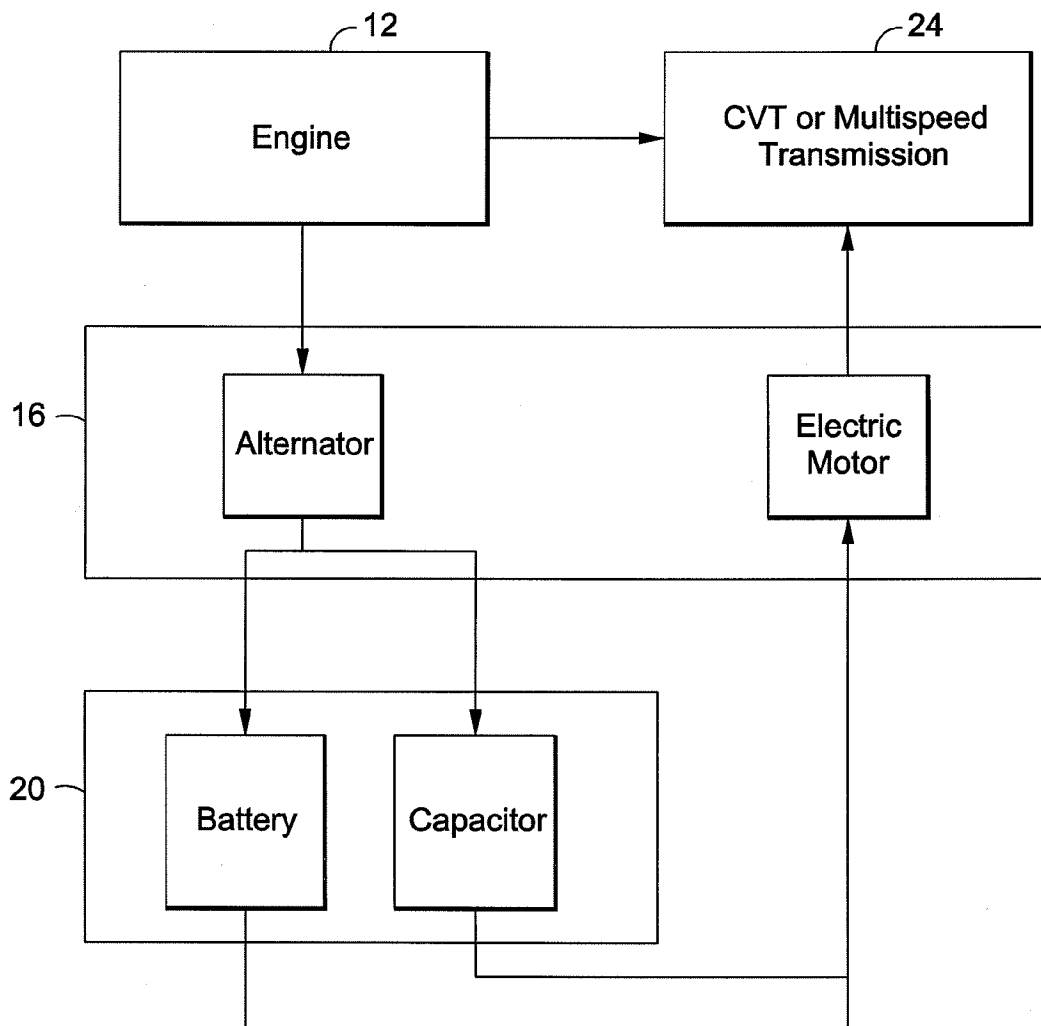

FIG. 1B

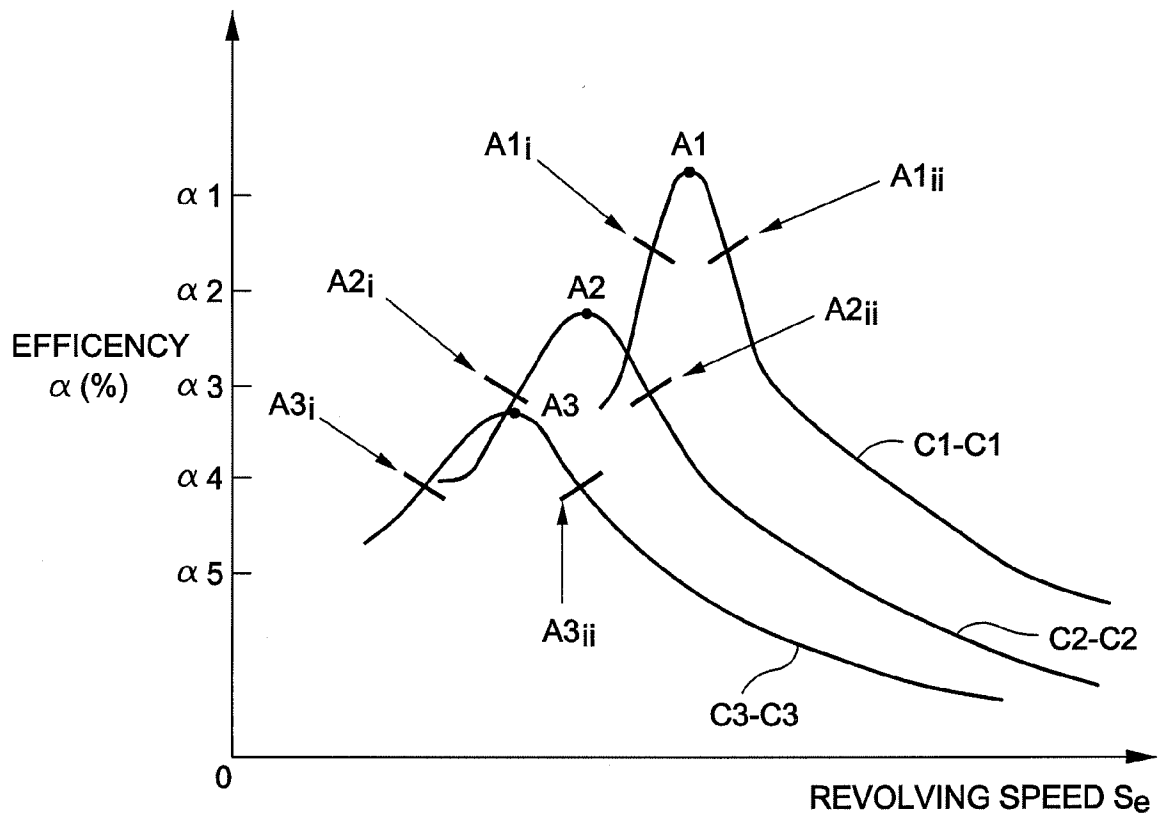

FIG. 2

4/11

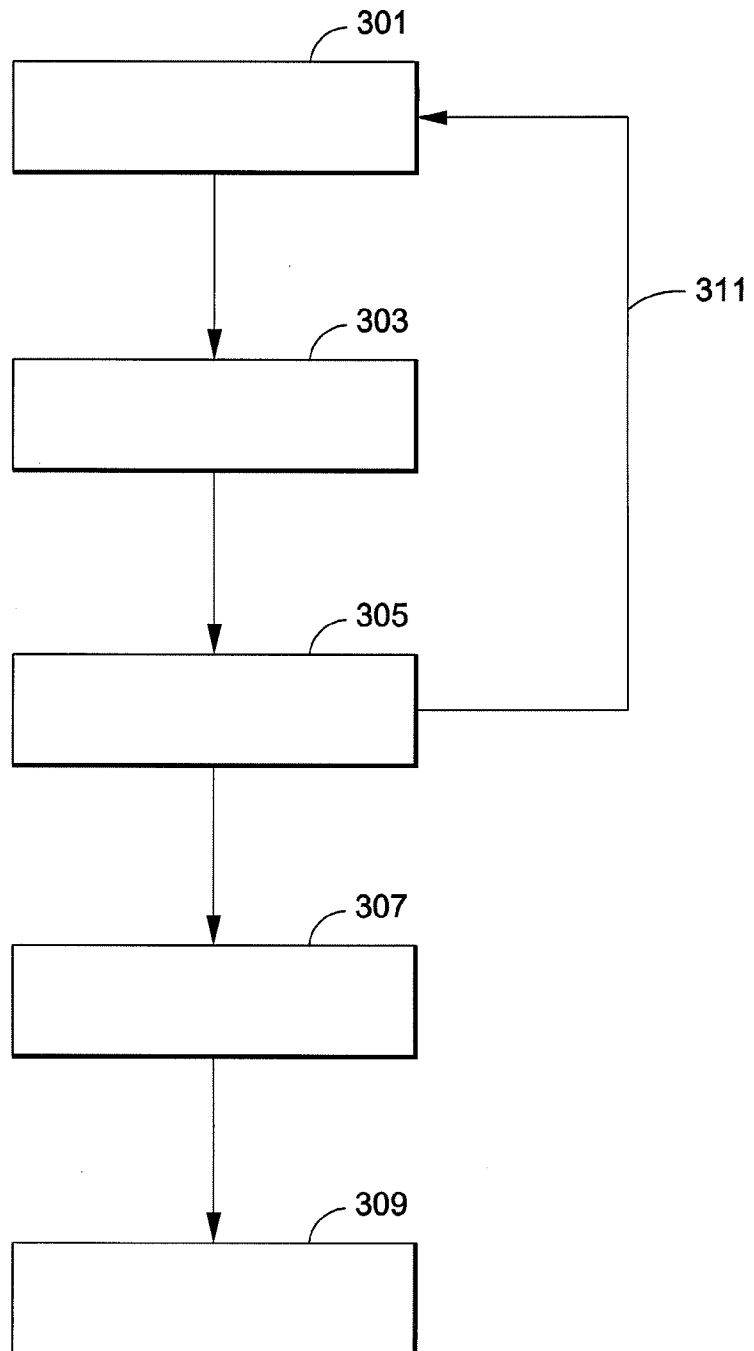

FIG. 3

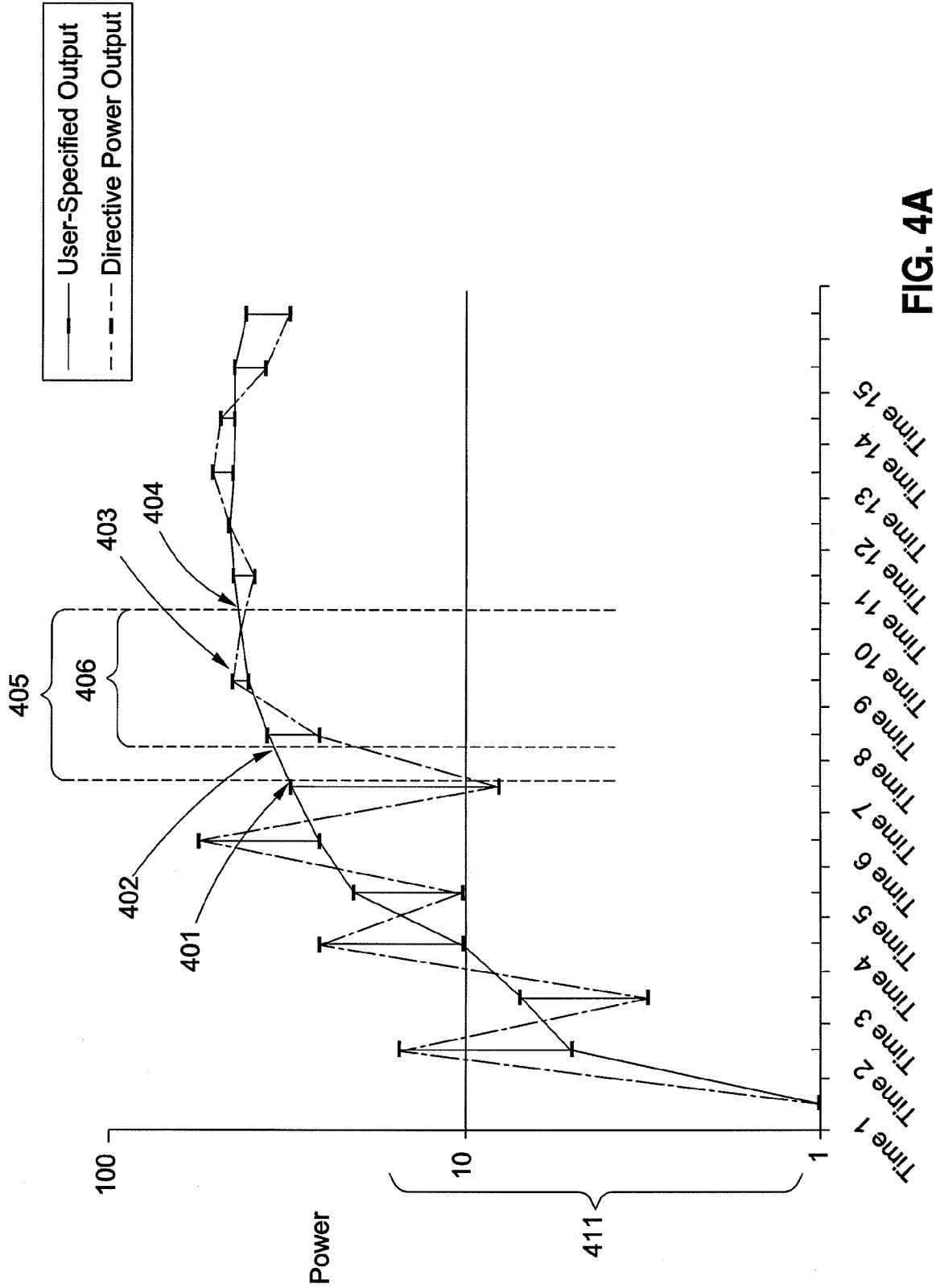

FIG. 4A

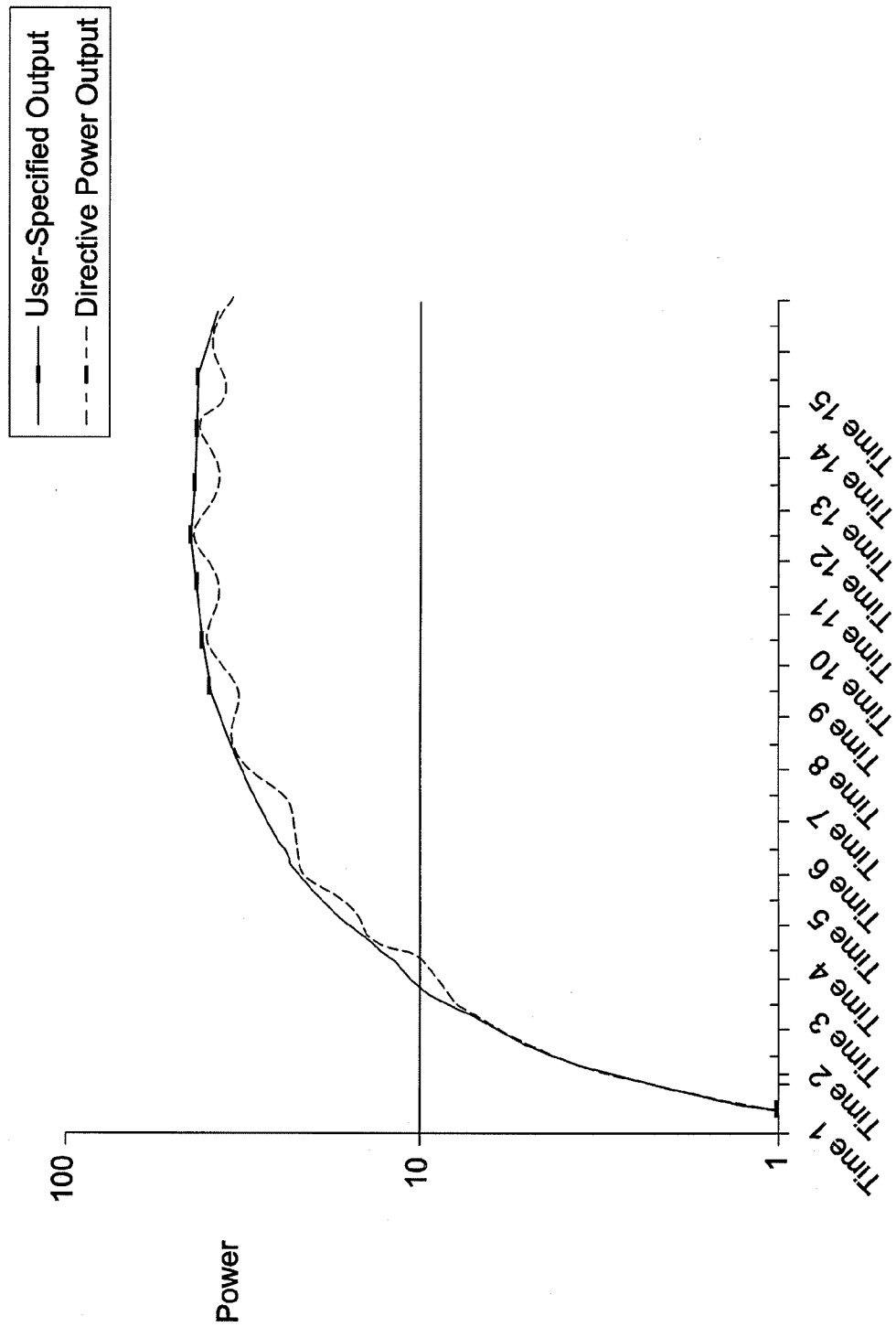

FIG. 4B

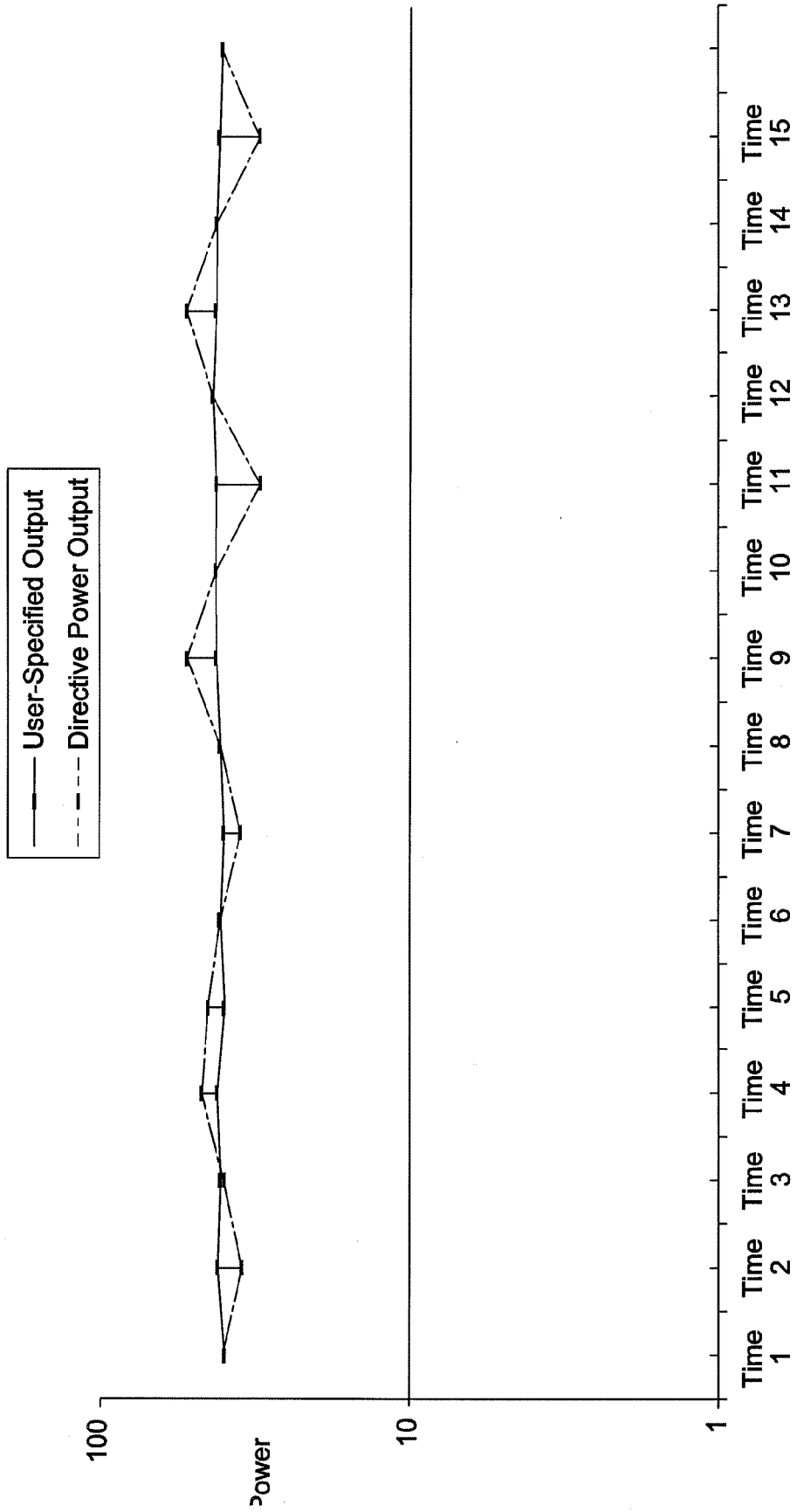

FIG. 5

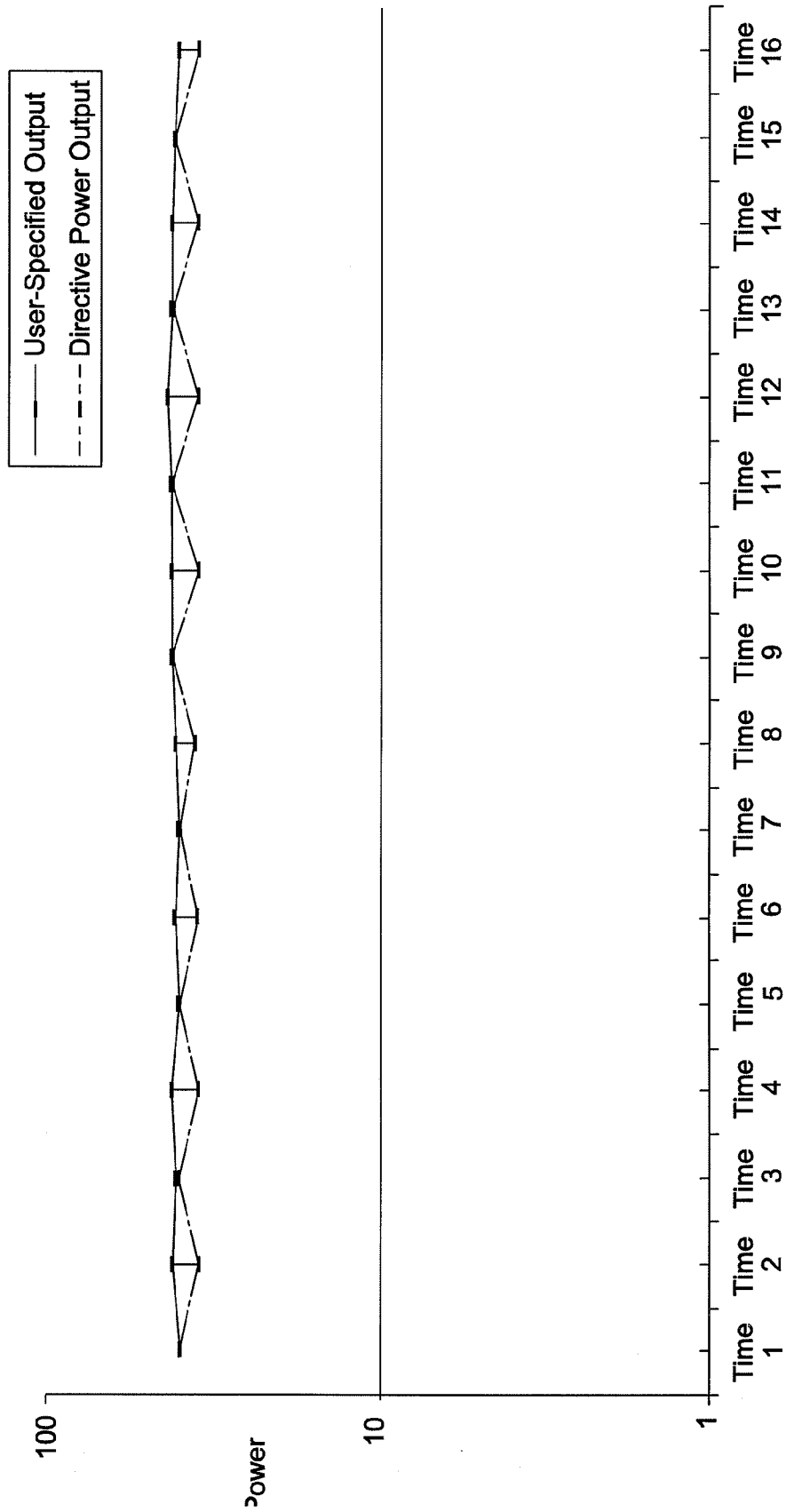

FIG. 6A

9/11

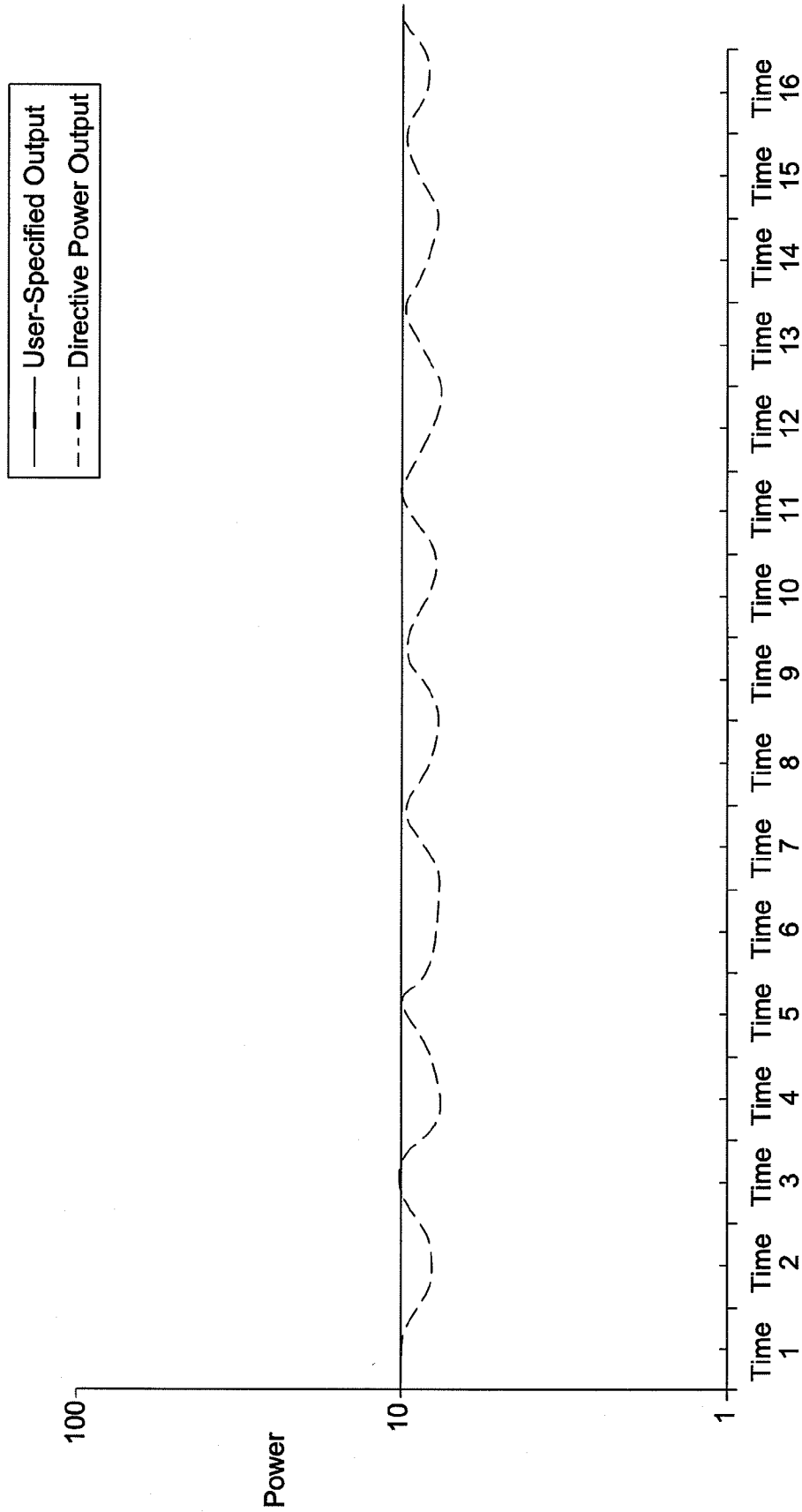

FIG. 6B

10/11

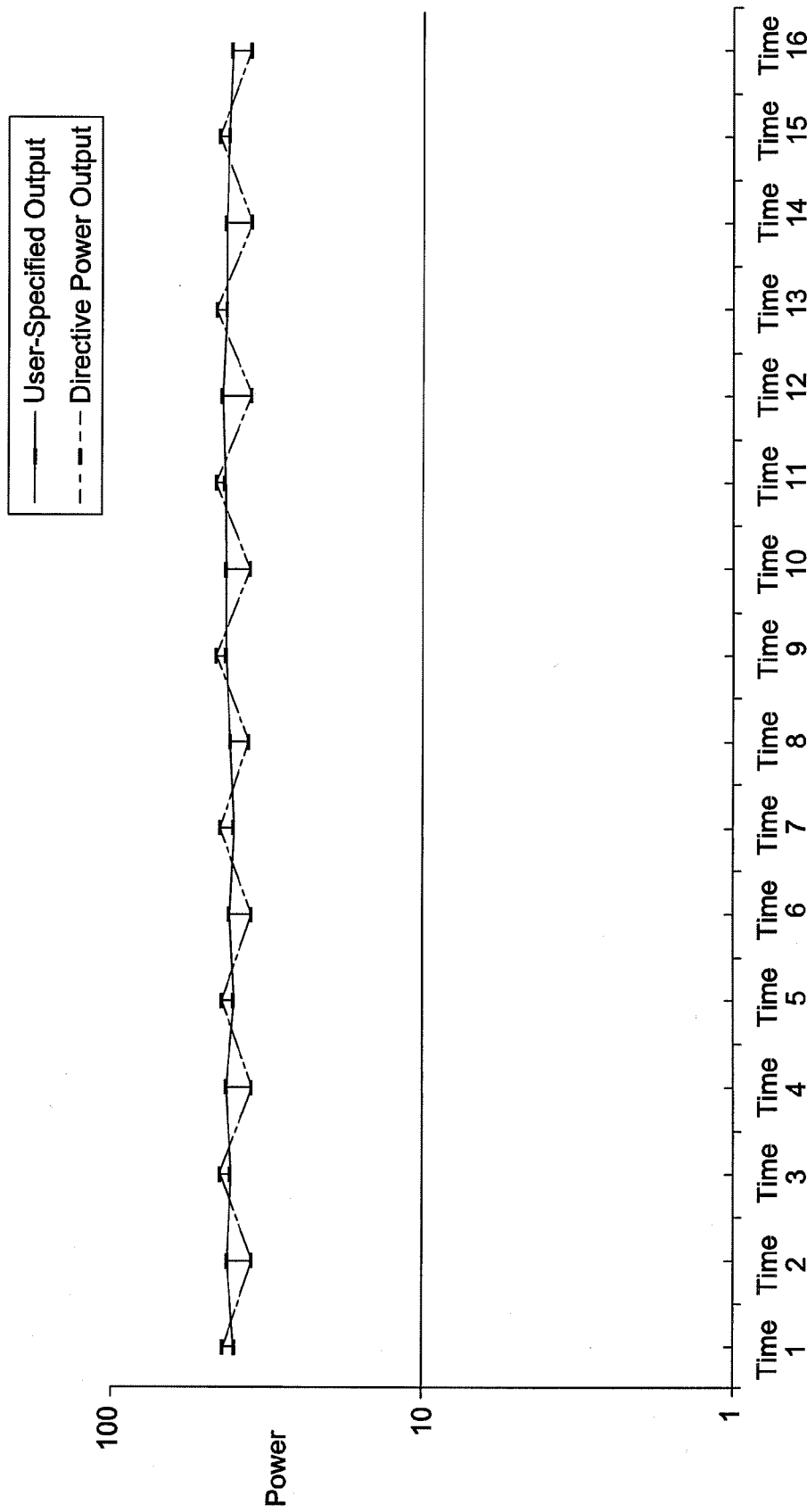

FIG. 7A

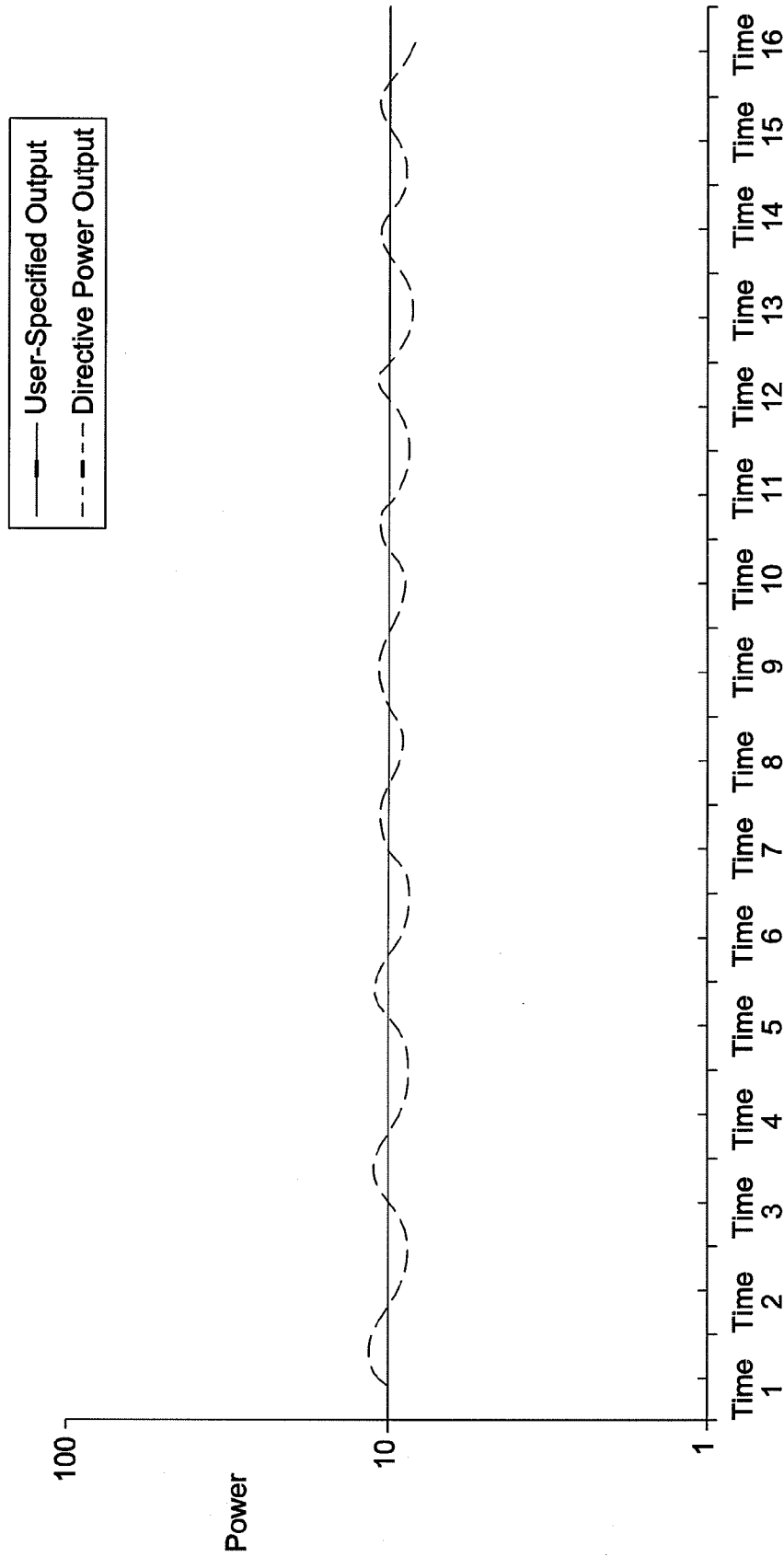

FIG. 7B

INTERNATIONAL SEARCH REPORT

International application No.
PCT/US2009/049640

A. CLASSIFICATION OF SUBJECT MATTER
 IPC(8) - F02M 11/06 (2009.01)
 USPC - 290/40C
 According to International Patent Classification (IPC) or to both national classification and IPC

B. FIELDS SEARCHED
 Minimum documentation searched (classification system followed by classification symbols)
 IPC(8) - F02M 11/06 (2009.01)
 USPC - 290/40C

Documentation searched other than minimum documentation to the extent that such documents are included in the fields searched

Electronic data base consulted during the international search (name of data base and, where practicable, search terms used)
 PatBase, Google Patents

C. DOCUMENTS CONSIDERED TO BE RELEVANT

| Category* | Citation of document, with indication, where appropriate, of the relevant passages | Relevant to claim No. |
|-----------|--|-----------------------|
| X --- | US 6,809,429 B1 (FRANK) 26 October 2004 (26.10.2004) entire document | 1, 4-11, 13-20, 23-29 |
| Y | | 2, 3, 12, 21, 22 |
| Y | US 5,841,201 A (TABATA et al) 24 November 1998 (24.11.1998) entire document | 2, 3, 12, 21, 22 |
| A | US 6,945,905 B2 (TAMAI et al) 20 September 2005 (20.09.2005) entire document | 1-29 |

Further documents are listed in the continuation of Box C.

* Special categories of cited documents:

| | |
|---|--|
| "A" document defining the general state of the art which is not considered to be of particular relevance | "T" later document published after the international filing date or priority date and not in conflict with the application but cited to understand the principle or theory underlying the invention |
| "E" earlier application or patent but published on or after the international filing date | "X" document of particular relevance; the claimed invention cannot be considered novel or cannot be considered to involve an inventive step when the document is taken alone |
| "L" document which may throw doubts on priority claim(s) or which is cited to establish the publication date of another citation or other special reason (as specified) | "Y" document of particular relevance; the claimed invention cannot be considered to involve an inventive step when the document is combined with one or more other such documents, such combination being obvious to a person skilled in the art |
| "O" document referring to an oral disclosure, use, exhibition or other means | "&" document member of the same patent family |
| "P" document published prior to the international filing date but later than the priority date claimed | |

| | |
|---|---|
| Date of the actual completion of the international search 14 August 2009 | Date of mailing of the international search report 27 AUG 2009 |
| Name and mailing address of the ISA/US Mail Stop PCT, Attn: ISA/US, Commissioner for Patents P.O. Box 1450, Alexandria, Virginia 22313-1450 Facsimile No. 571-273-3201 | Authorized officer: Blaine R. Copenheaver PCT Helpdesk: 571-272-4300 PCT OSP: 571-272-7774 |