

(19) World Intellectual Property Organization
International Bureau



(43) International Publication Date
18 August 2011 (18.08.2011)

PCT

(10) International Publication Number
WO 2011/100537 A1

- (51) International Patent Classification:
E21B 17/22 (2006.01)
- (21) International Application Number:
PCT/US2011/024510
- (22) International Filing Date:
11 February 2011 (11.02.2011)
- (25) Filing Language: English
- (26) Publication Language: English
- (30) Priority Data:
61/304,703 15 February 2010 (15.02.2010) US
13/025,438 11 February 2011 (11.02.2011) US
- (71) Applicant (for all designated States except US):
FRANK'S INTERNATIONAL, INC. [US/US]; 10260
Westheimer Road, Suite 700, Houston, TX 77042 (US).
- (72) Inventors; and
- (75) Inventors/Applicants (for US only): BUYTAERT, Jean,
P. [FR/US]; 7541 FM 1195, Mineral Wells, TX 76067
(US). MCDANIEL, Troy [US/US]; 144 Sanders Rd.,
Weatherford, TX 76087 (US).
- (74) Agent: EHRlich, Henry, L.; Winstead PC, PO Box
50784, Dallas, TX 75201 (US).
- (81) Designated States (unless otherwise indicated, for every
kind of national protection available): AE, AG, AL, AM,
AO, AT, AU, AZ, BA, BB, BG, BH, BR, BW, BY, BZ,
CA, CH, CL, CN, CO, CR, CU, CZ, DE, DK, DM, DO,
DZ, EC, EE, EG, ES, FI, GB, GD, GE, GH, GM, GT,
HN, HR, HU, ID, IL, IN, IS, JP, KE, KG, KM, KN, KP,
KR, KZ, LA, LC, LK, LR, LS, LT, LU, LY, MA, MD,
ME, MG, MK, MN, MW, MX, MY, MZ, NA, NG, NI,
NO, NZ, OM, PE, PG, PH, PL, PT, RO, RS, RU, SC, SD,
SE, SG, SK, SL, SM, ST, SV, SY, TH, TJ, TM, TN, TR,
TT, TZ, UA, UG, US, UZ, VC, VN, ZA, ZM, ZW.
- (84) Designated States (unless otherwise indicated, for every
kind of regional protection available): ARIPO (BW, GH,
GM, KE, LR, LS, MW, MZ, NA, SD, SL, SZ, TZ, UG,
ZM, ZW), Eurasian (AM, AZ, BY, KG, KZ, MD, RU, TJ,
TM), European (AL, AT, BE, BG, CH, CY, CZ, DE, DK,
EE, ES, FI, FR, GB, GR, HR, HU, IE, IS, IT, LT, LU,
LV, MC, MK, MT, NL, NO, PL, PT, RO, RS, SE, SI, SK,
SM, TR), OAPI (BF, BJ, CF, CG, CI, CM, GA, GN, GQ,
GW, ML, MR, NE, SN, TD, TG).

[Continued on next page]

(54) Title: DEVICE AND METHOD FOR AFFECTING THE FLOW OF FLUID IN A WELLBORE

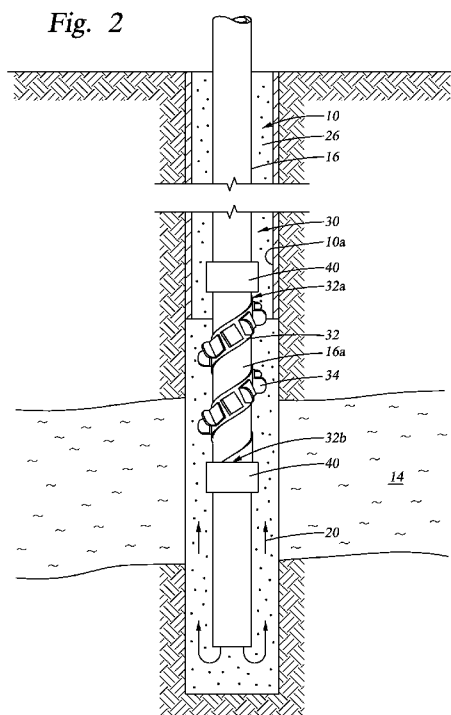

(57) Abstract: An apparatus to alter the flow of a fluid (e.g., drilling fluid, mud, cement, etc.) in a wellbore for example by creating turbulence in the flowing fluid. In one embodiment the apparatus includes a plurality of blade members extending outward from an elongated member. The elongated member is attached to the exterior surface of a tubular that is then positioned in a wellbore. The apparatus passively altering the flow of a fluid in the wellbore.

WO 2011/100537 A1

Published:

— with international search report (Art. 21(3))

**DEVICE AND METHOD FOR AFFECTING THE FLOW OF FLUID IN A
WELLBORE**

BACKGROUND

[0001] This section provides background information to facilitate a better understanding of the various aspects of the invention. It should be understood that the statements in this section of this document are to be read in this light, and not as admissions of prior art.

[0002] Wellbore operations commonly require circulating a fluid (e.g., drilling fluid, mud, cement, etc.) down a tubular disposed in the wellbore and at least partial back up the wellbore toward the surface. For example, during drilling operations a drilling fluid (e.g., mud) is circulated to suspend and carry the drilling cuttings to the surface. Mud is typically pumped down through the inner flow bore of the drill string, out through a drill bit at the bottom of the borehole, and back up through the annulus formed between the drill string and the wellbore wall. It is also common for the drilling fluid to be utilized to power a drilling motor disposed in the bottomhole assembly ("BHA") of the drill string. In vertical wellbores, the velocity vector of the flowing fluid counters the gravity vector. When the velocity vector opposes the gravity vector, the cuttings are easily suspended and lifted from the wellbore. In high-angle wellbores (e.g., deviated, horizontal) the velocity vector of the flowing fluid deviates from vertical while the gravity vector remains vertical. In these wellbores the cuttings tend to settle out of the circulating fluid, e.g., on the low side of the wellbore, forming cutting beds in the wellbore. These cutting beds often result in stuck pipe.

[0003] It is common to cement a tubular (e.g., casing, liner) in at least a portion of the wellbore to complete the well. Aside from completions, cementing operations are performed, for example, but not limited to, for remedial actions (e.g., squeezes), plugging sections of wells, setting bridge plugs and plugging and abandoning wells. Cementing operations are relatively expensive operations within themselves and incomplete and/or unsuccessful cementing operations can result in lost time, lost equipment, and from time to time loss of production or injection capabilities. An unsuccessful cementing operation can result, for example, from an insufficient volume of cement slurry used, too short of setting time and/or a poor distribution of the cement slurry around the tubular. One characteristic of a successful cementing operation may be creating a substantially homogeneous seal (e.g., cement layer) around the tubular.

SUMMARY

[0004] According to one or more aspects of the invention, an apparatus comprises a tubular having an exterior surface; an elongated member disposed on the exterior surface, wherein a first end of the elongated member is attached to the tubular at a first position and a second end of the elongated member is attached to the tubular at a second position spaced axially away from the first position; and a plurality of blade members extending radially away from the elongated member and the tubular, wherein the blade members are adapted to induce turbulence in a fluid flowing across the exterior surface of the tubular.

[0005] A method, according to one or more aspects of the invention, comprises providing an elongated member having a first end, a second end and a plurality of blade members extending radially away from the elongated member; positioning the elongated member on a tubular, wherein the first end and the second end are spaced axially apart on the tubular and the plurality of blade members extend radially away from the elongated member and the tubular; and disposing the tubular in a wellbore.

[0006] A method for affecting the flow of a fluid in a wellbore according to one or more aspects of the invention comprises providing an apparatus comprising an elongated member having a plurality of blade members extending radially from the elongated member; disposing a bottom surface of the elongated member on a tubular; attaching a first end of the elongated member at a first fixed position on the tubular; moving a second end of the elongated member angularly relative to the longitudinal axis of the tubular to a second fixed position spaced axially from the first fixed position; attaching the second end of the elongated member to the tubular at the second fixed position; and deploying the tubular and connected apparatus in a wellbore.

[0007] The foregoing has outlined some of the features and technical advantages of the invention in order that the detailed description of the invention that follows may be better understood. Additional features and advantages of the invention will be described hereinafter which form the subject of the claims of the invention.

BRIEF DESCRIPTION OF THE DRAWINGS

[0008] The invention is best understood from the following detailed description when read with the accompanying figures. It is emphasized that, in accordance with standard practice in the industry, various features are not drawn to scale. In fact, the dimensions of various features may be arbitrarily increased or reduced for clarity of discussion.

[0009] **Figure 1** is a schematic view of an apparatus according to one or more aspects of the invention disposed in a wellbore.

[0010] **Figure 2** is a schematic view of another embodiment of an apparatus according to one or more aspects of the invention disposed in a wellbore.

[0011] **Figure 3** is a schematic, perspective view of an apparatus according to one or more aspects of the invention depicting blade members attached to an elongated base member.

[0012] **Figure 4** is a schematic view another embodiment of an apparatus according to one or more aspects of the invention depicting blade members having a lateral leg disposed below an elongated member.

[0013] **Figures 5A-5F** are schematic views depicting examples of profiles of blade members according to one or more aspects of the invention.

[0014] **Figure 6** is a schematic view of an embodiment of an apparatus according to one or more aspects of the invention disposed on a tubular.

[0015] **Figure 7** is a schematic view of another embodiment of an apparatus according to one or more aspects of the invention disposed on a tubular.

[0016] **Figures 8A and 8B** are schematic depictions of one or more aspects the apparatus of the invention.

[0017] **Figure 9** is a schematic view of another embodiment of an apparatus according to one or more aspects of the invention.

[0018] **Figure 10** is a schematic view of another embodiment of an apparatus according to one or more aspects of the invention.

DETAILED DESCRIPTION

[0019] It is to be understood that the following disclosure provides many different embodiments, or examples, for implementing different features of various embodiments. Specific examples of components and arrangements are described below to simplify the invention. These are, of course, merely examples and are not intended to be limiting. In addition, the invention may repeat reference numerals and/or letters in the various examples. This repetition is for the purpose of simplicity and clarity and does not in itself dictate a relationship between the various embodiments and/or configurations discussed.

[0020] As used herein, the terms "up" and "down"; "upper" and "lower"; "top" and "bottom"; and other like terms indicating relative positions to a given point or element are utilized to more clearly describe some elements. Commonly, these terms relate to a reference point as the surface from which drilling operations are initiated as being the top point and the total depth of the well being the lowest point, whether the well (e.g., wellbore, borehole) is vertical, horizontal or slanted relative to the surface. The terms "pipe," "tubular," "tubular member," "tubular string," "casing," "liner," tubing," "drill pipe," "drill string" and other like terms can be used interchangeably. The terms may be used in combination with "joint" to mean a single unitary length; a "stand" to mean one or more, and typically two or three, interconnected joints; or a "string" meaning two or more interconnected joints.

[0021] In this disclosure, "fluidically coupled" or "fluidically connected" and similar terms may be used to describe bodies that are connected in such a way that fluid pressure may be transmitted between and/or among the connected items. The term "in fluid communication" is used to describe bodies that are connected in such a way that fluid can flow between and/or among the connected items. It is noted that fluidically coupled may include certain arrangements where fluid may not flow between the items, but the fluid pressure may nonetheless be transmitted. Thus, fluid communication is a subset of fluidically coupled.

[0022] Figure 1 is a schematic of an apparatus according to one or more aspects of the invention. Figure 1 generally depicts a wellbore 10 being drilled from a surface 12, e.g., from a rig (not shown), into a subterranean formation 14. A tubular 16 (e.g., drillpipe, coil tubing, etc.) having a drill bit 18 connected at the end of the tubular distal from surface 12 is depicted drilling wellbore 10. Fluid 20 (e.g., drilling fluid, mud) is depicted as being

circulated from a reservoir 22 (e.g., tank, pit) via a pump 24, down the interior bore of the tubular and is discharged at drill bit 18 and circulated back to surface 12 through the annulus 26 formed between the tubular and the wellbore 10 wall 10a in this depiction. Fluid 20 is utilized, at least in part, for carrying drill cuttings 28 (e.g., debris) to surface 12. A common problem encountered while drilling, in particular drilling non-vertical sections, is that cuttings 28 drop out of the fluid 20 stream flowing in annulus 26 and form cutting beds, e.g., in the low side of wellbore 10. The formation of cutting beds, e.g., being an obstruction in the annulus, can result in the tubular becoming stuck in the wellbore and limit the length (e.g., total depth) and/or deviation from vertical that a wellbore can achieve.

[0023] According to one or more aspects of the invention, an apparatus 30 is positioned on and/or about a portion (e.g., tubular joint, sub, drill collar, motor, etc.) of the tubular. Apparatus 30 includes an elongated base member 32 (e.g., band, strap, etc.) connected to the tubular. For example, at least the opposing ends of the base member are attached to tubular 16. A plurality of spaced apart blade members 34 extend radially outward (e.g., away) from base member 32 and tubular 16 into annulus 26 and the flow fluid 20.

[0024] Depicted in Figure 1, apparatus 30 is disposed proximate to drill bit 18, for example, along the bottomhole assembly ("BHA") 36. Apparatus 30 may be utilized with a rotating tubular (e.g., rotary drilling) and non-rotating portions such as a system utilizing a mud motor. In the depicted example, apparatus 30 is disposed between opposing stabilizers 38. Substantially rigid standoffs (e.g., stabilizers 38) may be utilized to limit the contact of apparatus 30 with the wall of the wellbore to prevent the blade members from contacting the wall and/or being damaged, e.g., crushed. Base member 32 and blade members 34 may be constructed of the same or different types of material (e.g., metal, composites, elastomers). It may be desired for apparatus 30 or at least for blade members 34 to be constructed of a drillable material.

[0025] According to one or more aspects of the invention, apparatus 30 passively induces turbulence in the flow of fluid 20 which may promote maintaining cuttings 28 in the flowing fluid 20 increasing the removal of cuttings 28. Apparatus 30 provides beneficial turbulence in fluid 20 and helps reduce the equivalent circulating density ("ECD") of fluid 20. The effective density exerted by a circulating fluid against the formation that takes into account the pressure drop in the annulus above the point being considered. The ECD is calculated as:

$d + P/[0.052*D]$; wherein "d" is the mud weight (e.g., pounds/gallon), "D" is the true vertical depth (e.g., feet) from the surface to the point considered, and "P" is the pressure drop in the annulus between depth D and the surface (e.g., psi). The ECD is an important parameter in avoiding kicks and losses, particularly in wells that have a narrow window between the fracture gradient and the pore-pressure gradient of the formation.

[0026] Figure 2 is a schematic of an apparatus 30 according to one or more aspects of the invention disposed in a wellbore 10. Figure 2 depicts a cementing operation being performed in wellbore 10. Wellbore 10 is depicted as a vertical wellbore, however, methods of the invention may be performed in vertical and non-vertical wellbores. In this example, a tubular 16, or at least a portion of a tubular, is being cemented in wellbore 10. In this example, fluid 20 is cement (e.g., cement slurry) which is pumped into the well through the interior bore of tubular 16, discharged into wellbore 10 and pumped to a desired level in annulus 26 formed in this example between tubular 16 and the wall 10a of wellbore 10.

[0027] Apparatus 30 is connected to tubular 16 and comprises an elongated base member 32 disposed along the exterior surface 16a of a portion of tubular 16 having a plurality of spaced apart blade members 34 extending radially away from tubular 16 into annulus 26 and the flowing fluid 20. According to one or more aspects of the invention, apparatus 30 is adapted to alter the flow of fluid 20 and to induce turbulence in fluid 20. Depicted in Figure 2, the opposing ends 32a, 32b, (e.g., first and second ends) of base member 32 are attached to tubular 16 to secure apparatus 30 at least axially relative to a position on the tubular. In Figure 2, apparatus 30 is attached to tubular 16 at ends 32a, 32b by members 40 (e.g., stop collars as are known in the art). According to one or more aspects of the invention, base member 32 may not be attached to tubular 16 between first and second ends 32a, 32b thereby permitting some movement of blade members 34 in fluid 20.

[0028] Apparatus 30 may be attached to tubular 16 between devices such as stabilizers or centralizers or as depicted in Figure 1. The configuration depicted in Figure 2 may facilitate scraping of the mud cake from wall 10a and promote a better cement bond.

[0029] Figure 3 is a schematic, perspective view of an apparatus 30 according to one or more aspects of the invention. Depicted apparatus 30 comprises an elongated planar base member 32 having a top surface 32c and a bottom surface 32d. In this example, a hole 42 is formed at first end 32a and second end, 32b for attaching apparatus 30 directly to tubular 16 and/or to a

member 40 (e.g., Figure 2), for example by a bolt, screw, rivet, etc. Depicted blade members 34 are axially spaced apart along base member 32 and extend radially away from top surface 32c and away from bottom surface 32d which is adapted to be disposed against tubular 16 as illustrated in Figures 1 and 2. Blade members 34 (e.g., deflectors) may be formed as a unitary portion (e.g., molding) of base member 32 (see Figure 6) or as a separate member from base member 32. Blade members 34 may be individual members having a lateral leg 34a and a radial leg 34b. Apparatus 30 depicted in Figure 6 is constructed as a unitary piece (e.g., molding, etc.) wherein blade members 34 extend radially away from base member 32. In Figure 3, lateral leg 34a is disposed on top surface 32c of base member 32 so that radial leg 34b extends away from surface 32c. Blade members 34 may be attached to base member 32 in various manners including bolting, welding, adhesives, vulcanization, crimping, riveting, screws, molding and the like. In some embodiments, blade members 34 may be moveably attached to base member 32 for example to rotate (e.g., swivel) relative to base member 32. Movement may be limited to a selected range of movement. Depicted in Figure 3, blade members 34 are attached to base member 32 via a connector 44 depicted as a rivet. Connector 44 may rigidly, e.g., preventing movement, attach blade members 34 and base member 32 or provide a moveable attachment of blade members 34 to base member 32.

[0030] Figure 4 is a schematic of an embodiment of apparatus 30 according to one or more aspects of the invention. In this example, base member 32 and blade members 34 are separate members. Lateral legs 34a are depicted disposed below base member 32 and extending along bottom surface 32b. Radial legs 34b extend from lateral legs 34a through slots 46 in base member 32. Blade members 34 are again depicted attached to base member 32 via connectors 44. One or more of blade members 34 may be rigidly (e.g., fixedly) attached to base member 32 (e.g., stationary relative to base member 32) and/or moveably (e.g., swivelingly, pivotedly, rotatingly) attached.

[0031] Figures 5A through 5F are schematic illustrations of examples of blade members 34 according to one or more aspects of the invention. As described above, blade members 34 may be formed as a unitary portion of base member 32 (e.g., molding) as depicted in Figure 6 for example. In Figures 5A-5F, blade members 34 are illustrated as individual members for purposes of illustration. According to one or more aspects of the invention, blade members 34 may be constructed to induce turbulence in fluid flow. For example, blade members 34, in particular radial legs 34b, may comprise apertures 48 and/or textured or roughened edges 50.

The profile of radial leg 34b may take various shapes, but not limited to those which are depicted in Figures 5A to 5F.

[0032] Figure 6 is a schematic of an apparatus 30 according to one or more aspects of the invention. Apparatus 30 is depicted disposed in a spiral pattern about tubular 16. Base member 32 is disposed on exterior surface 16a of tubular 16. First and second ends 32a, 32b are spaced axially apart relative to tubular 16. In this embodiment, ends 32a, 32b are physically attached to tubular 16 for example by connector 52 disposed for example with hole 42 (Figure 3). Connector 52 may include or represent, without limitation, one or more of a bolt, screw, weld, adhesive (e.g., epoxy) or the like. Depicted in Figure 6, connectors 52 are bolt type members attaching ends 32a, 32b to tubular 16 in a manner limiting or preventing axial movement along tubular 16 but allowing rotational movement (e.g., non-axial, pivoting, swiveling, rotating) relative to tubular 16 and connector 52. A rotational type connection at end 32a and/or end 32b, according to one or more aspects of the invention, facilitates movement of apparatus 30 (e.g., blade members 34) in response to fluid flow and/or movement of tubular 16.

[0033] Figure 6 depicts blade members 34 as planar members extending outwardly from base member 32 and tubular 16. Blade members 34 may be attached to base member 32 (e.g., welded) or may be of a unitary construction (e.g., same piece of material) as base member 32 (e.g., molded). Blade members 34 (e.g., radial legs) may be oriented in various manners relative to base 32 and/or tubular 16. For example, some or all of the blade members 34 may be oriented substantially parallel to one another or at non-perpendicular angles between adjacent blade members. Blade members 34 may be oriented parallel to the longitudinal axis of tubular 16 or at a non-perpendicular angle from the longitudinal axis of tubular 16 as depicted in Figure 6. Blade members 34 may be oriented parallel to the longitudinal axis of base member 32 or at a non-perpendicular angle from the longitudinal axis of base member 32.

[0034] Figure 7 is a schematic view of an apparatus 30 according to one or more aspects of the invention. In this example, ends 32a, 32b of apparatus 30 are attached (e.g., secured) to tubular 16 by members 40 (e.g., stop collars). As described above, end 32a and/or end 32b may be attached to tubular 16 in a manner permitting non-axial movement (e.g., pivoting, swiveling, rotating) or rigidly attached to restrict or eliminate axial and non-axial movement.

[0035] Apparatus 30 may be disposed on tubular 16 in various patterns depicted in the Figures and not depicted. As will be understood by one skilled in the art with access to this disclosure, apparatus 30 may be disposed in a spiral (e.g., helical) pattern around a portion of tubular 16, partially circling tubular 16 and with base member 32 aligned parallel with the longitudinal axis of tubular 16.

[0036] Figures 8A and 8B are conceptual schematics illustrating the positioning of an apparatus with a tubular according to one or more aspects of the invention. The tubular is conceptually represented by longitudinal axis 16X. Base member 32 is depicted disposed on the tubular and extending between members 40a and 40b (e.g., stop collars) for purposes of attaching the opposing ends of base member 32 to the tubular. In Figure 8A, base member 32 is depicted disposed on the tubular extending substantially parallel to longitudinal axis 16X and the vertical (y-axis) plane of longitudinal axis 16X. As such, first end 32a is attached at a first fixed position 54 (e.g., relative to the tubular) by a connector 52a and second end 32b is attached at a second fixed position 56 denoted by connector 52b. In this embodiment, first end 32a and second end 32b are angularly aligned at 0 degrees (e.g., relative to one another and the tubular) for purposes of description.

[0037] In Figure 8B, first end 32a may be moveably attached (e.g., non-axially moveable) to the tubular at a first fixed position 54 (e.g., via connector 52 and member 40a). Second end 32b of base member 32 may then be angularly rotated relative to the tubular (e.g., longitudinal axis 16X) and the first fixed position 54 to the desired second fixed position 56. In the depicted embodiment, the angular movement of second end 32b to second fixed position 56 relative to first fixed position 54 disposes base member 32 (and the blade members) in a spiral configuration relative to the tubular. Second end 32b may be rigidly or non-axially moveably attached at the second position depicted by connector 52b and member 40b. A non-axially moveable attachment between member 40b and end 32b at connector 52b facilitates non-axial movement and an axially fixed attachment of end 32b to the tubular. Member 40b may be attached to the tubular in a manner to secure end 32b at second fixed position 56.

[0038] Figure 9 is a schematic view of another embodiment of an apparatus 30 according to one or more aspects of the invention. In this embodiment, apparatus 30 is attached to tubular 16 via an adhesive 60 (e.g., epoxy) indicated by the dashed lines. Apparatus 30 can be

attached at its opposing ends 32a, 32b to tubular 16 without securing base member 32 to tubular 60 along the portion between ends 32a, 32b in a manner such that blade members 34 are moveable relative to tubular 16. In some embodiments, apparatus 30 may be attached (e.g., secured) substantially along its length to tubular 16 as depicted in Figure 9. Apparatus 30 depicted in Figure 9 comprises a unitary apparatus wherein blade members 34 are formed as a unitary portion of base member 32.

[0039] Figure 10 is a schematic view of another embodiment of an apparatus 30 according to one or more aspects of the invention. Apparatus 30 depicted in Figure 10 is attached to tubular 16 at its opposing ends 32a, 32b by an adhesive 60 indicated by the dashed lines. Figure 10 illustrates apparatus 30 (e.g., base member 32) held in a fixed position relative to tubular 16, via device 62, at least for a time period in which adhesive 60 is setting up. Device 62 may comprise any device adapted to hold apparatus 30 with tubular 16 for the desired period of time. For example, device 62 may be a clamp or an adhesive tape. The holding device 62 may be removed prior to running apparatus 30 into the wellbore. In some embodiments it may be desired to leave holding device in place when apparatus 30 is run into the wellbore. For example, with reference to Figure 1, apparatus 30 may be positioned between rigid offset wellbore offset devices such as stabilizers 38, thus providing protection to holding device 62 and/or apparatus 30 as it is being run into the wellbore.

[0040] The foregoing outlines features of several embodiments so that those skilled in the art may better understand the aspects of the invention. Those skilled in the art should appreciate that they may readily use the invention as a basis for designing or modifying other processes and structures for carrying out the same purposes and/or achieving the same advantages of the embodiments introduced herein. Those skilled in the art should also realize that such equivalent constructions do not depart from the spirit and scope of the invention, and that they may make various changes, substitutions and alterations herein without departing from the spirit and scope of the invention. The scope of the invention should be determined only by the language of the claims that follow. The term "comprising" within the claims is intended to mean "including at least" such that the recited listing of elements in a claim are an open group. The terms "a," "an" and other singular terms are intended to include the plural forms thereof unless specifically excluded.

WHAT IS CLAIMED IS:

1. An apparatus comprising:
a tubular having an exterior surface;
an elongated member disposed on the exterior surface, wherein a first end of the elongated member is attached to the tubular at a first position and a second end of the elongated member is attached to the tubular at a second position spaced axially away from the first position; and
a plurality of blade members extend radially away from the elongated member and the tubular, wherein the blade members are adapted to induce turbulence in a fluid flowing across the exterior surface of the tubular.
2. The apparatus of claim 1, wherein the plurality of blade members are rotationally attached to the elongated member.
3. The apparatus of claim 1, wherein the plurality of blade members are moveably attached to the elongated member.
4. The apparatus of claim 1, wherein at least the first end is rotationally attached to the tubular.
5. The apparatus of claim 1, wherein at least the first end is moveably attached to the tubular.

6. The apparatus of claim 1, wherein at least the first end is rotationally attached to the tubular and the plurality of blade members are rotationally attached to the elongated member.
7. The apparatus of claim 1, wherein at least the first end is moveably attached to the tubular and the plurality of blade members are moveably attached to the elongated member.
8. The apparatus of claim 1, wherein the elongated member is disposed in an axially spiraling configuration along a portion of the tubular.
9. The apparatus of claim 1, wherein the elongated member is disposed between substantially rigid stand-off members.
10. The apparatus of claim 1, wherein at least a first end of the elongated member is attached to the tubular by an adhesive.
11. A method comprising:
 - providing an elongated member having a first end, a second end and a plurality of blade members extending radially away from the elongated member;
 - positioning the elongated member on a tubular, wherein the first end and the second end are spaced axially apart on the tubular and the plurality of blade members extend radially away from the elongated member and the tubular; and
 - disposing the tubular in a wellbore.

12. The method of claim 11, wherein positioning comprises attaching the first end and the second end of the elongated member to the tubular.
13. The method of claim 12, wherein attaching comprising using an adhesive.
14. The method of claim 11, wherein positioning comprises attaching the first end and the second end of the elongated member to the tubular, wherein at least one of the first end and the second end is rotationally moveable relative to the tubular.
15. The method of claim 11, wherein positioning comprises attaching the first end and the second end of the elongated member to the tubular, wherein at least one of the first end and the second end is moveable relative to the tubular.
16. The method of claim 11, further comprising:
flowing a fluid across the plurality of blade members; and
inducing turbulence in the fluid in response to flowing across the blade members.
17. The method of claim 11, further comprising:
flowing a fluid across the plurality of blade members, the fluid comprising one
selected from the group of a drilling fluid and a cement slurry; and
inducing turbulence in the fluid in response to flowing across the blade members.

18. The method of claim 11, further comprising:
circulating a fluid through the wellbore, the circulating fluid flowing across the
plurality of blade members inducing turbulence in the circulating fluid; and
removing debris from the wellbore in response to the turbulence induced in the
circulating fluid.
19. The method of claim 11, wherein positioning comprises attaching the first end and the
second end of the elongated member to the tubular, wherein at least one of the first
end and the second end is rotationally moveable relative to the tubular; and further
comprising:
circulating a fluid through the wellbore, the circulating fluid flowing across the
plurality of blade members inducing turbulence in the circulating fluid; and
removing debris from the wellbore in response to the turbulence induced in the
circulating fluid.
20. The method of claim 11, wherein positioning comprises attaching at least the first end
of the elongated member to the tubular with an adhesive.
21. A method for affecting the flow of a fluid in a wellbore, comprising:
providing an apparatus comprising an elongated member having a plurality of radially
extending blade members;
disposing a bottom surface of the elongated member on a tubular;
attaching a first end of the elongated member at a first fixed position on the tubular;

moving a second end of the elongated member angularly relative to the longitudinal axis of the tubular to a second fixed position spaced axially from the first fixed position;

attaching the second end of the elongated member to the tubular at the second fixed position; and

deploying the tubular and connected apparatus in a wellbore.

22. The method of claim 21, wherein the elongated member and the plurality of blade members are of a unitary construction.
23. The method of claim 21, wherein the each of the plurality of blade members is an individual member attached to the elongated member.
24. The method of claim 21, wherein the plurality of blade members comprise a lateral leg positioned along the bottom surface of the elongated member and a radial leg extending through the elongated member.
25. The method of claim 21, further comprising positioning the elongated member between stand-off members attached to the tubular.
26. The method of claim 21, further comprising:
flowing a fluid across the plurality of blade members, the fluid comprising one selected from the group of a drilling fluid and a cement slurry; and
inducing turbulence in the fluid in response to flowing across the blade members.

27. The method of claim 21, further comprising:
circulating a fluid through the wellbore, the circulating fluid flowing across the
plurality of blade members inducing turbulence in the circulating fluid; and
removing debris from the wellbore in response to the turbulence induced in the
circulating fluid.
28. The method of claim 21, further comprising:
flowing a fluid across the plurality of blade members, the fluid comprising one
selected from the group of a drilling fluid and a cement slurry;
inducing turbulence in the fluid in response to flowing across the blade members; and
rotating the apparatus and the tubular while flowing the fluid across the plurality of
blade members.
29. The method of claim 21, further comprising:
discharging a cement slurry into the wellbore from the tubular;
pumping the cement slurry across the plurality of blade members to a desired level in
the wellbore; and
inducing turbulence in the cement slurry in response to pumping the cement slurry
across the plurality of blade members.
30. The method of claim 21, wherein attaching the first end to the tubular comprises using
an adhesive.

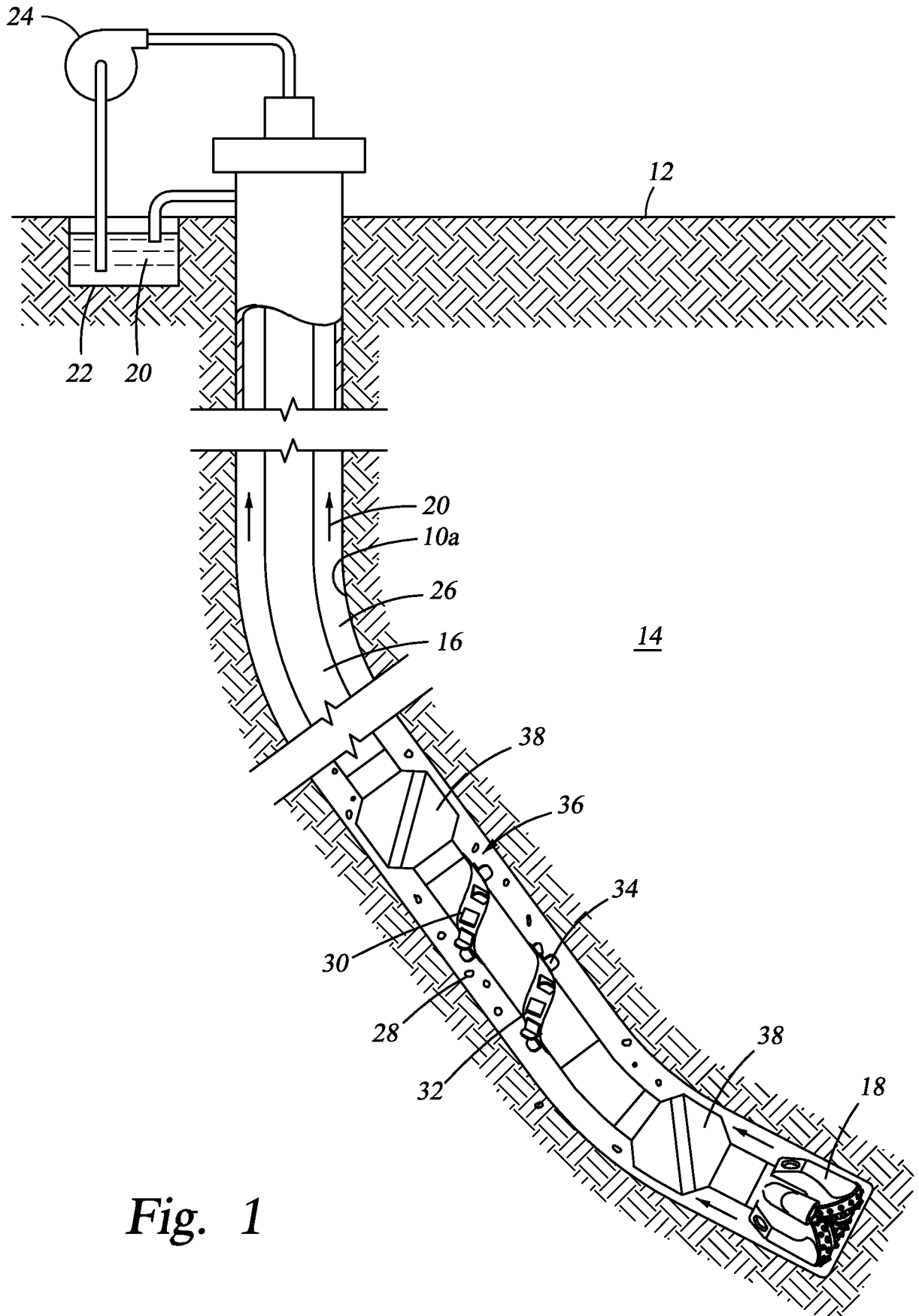

Fig. 1

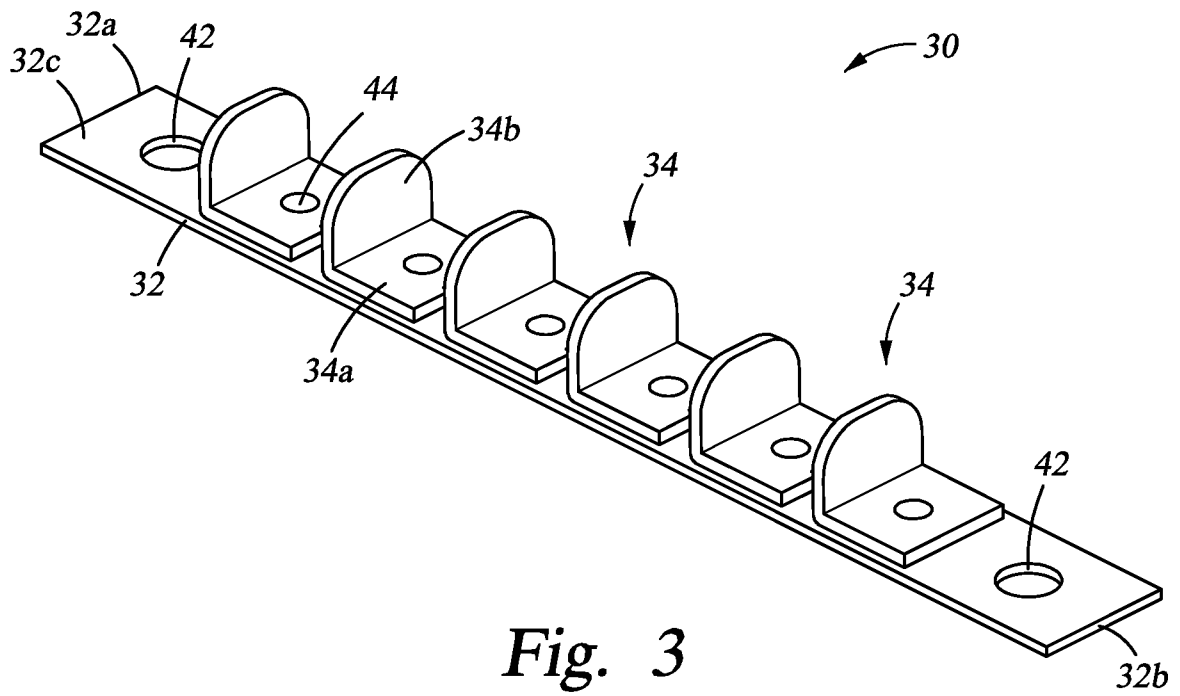

Fig. 3

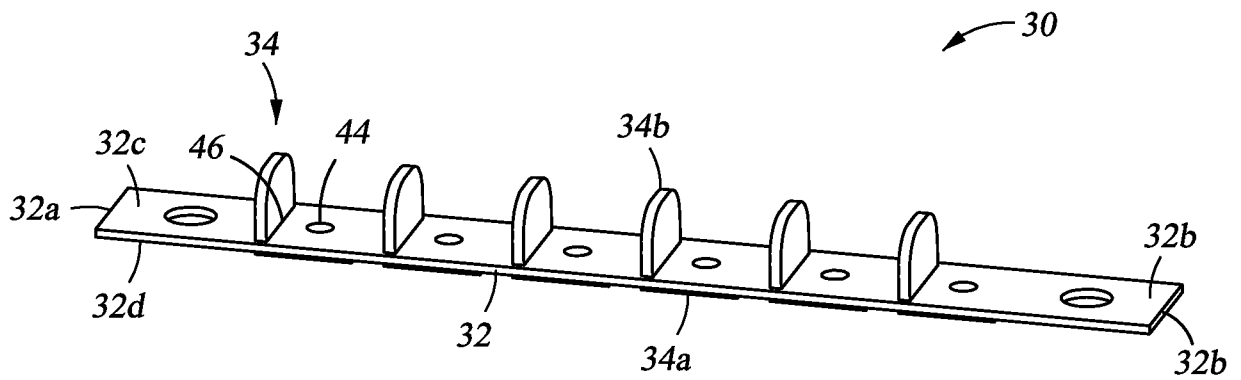

Fig. 4

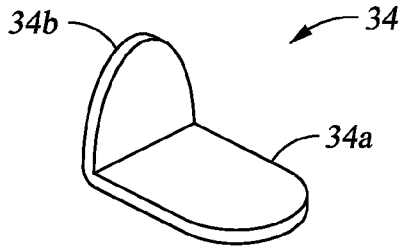

Fig. 5A

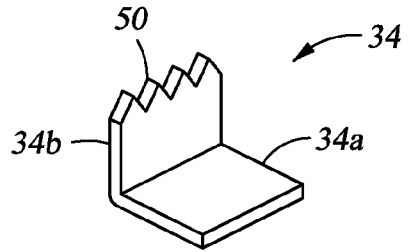

Fig. 5D

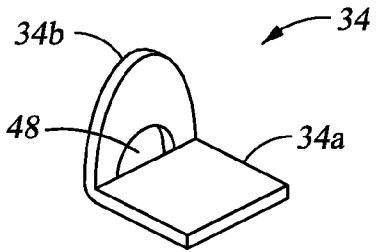

Fig. 5B

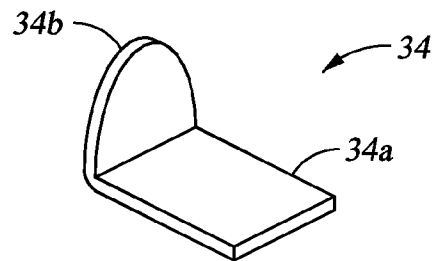

Fig. 5E

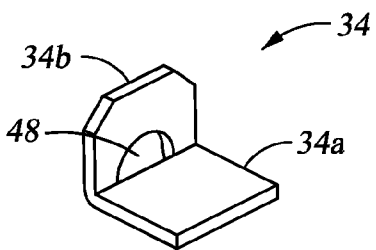

Fig. 5C

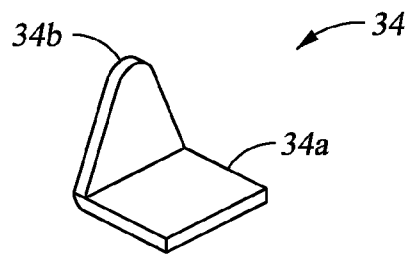

Fig. 5F

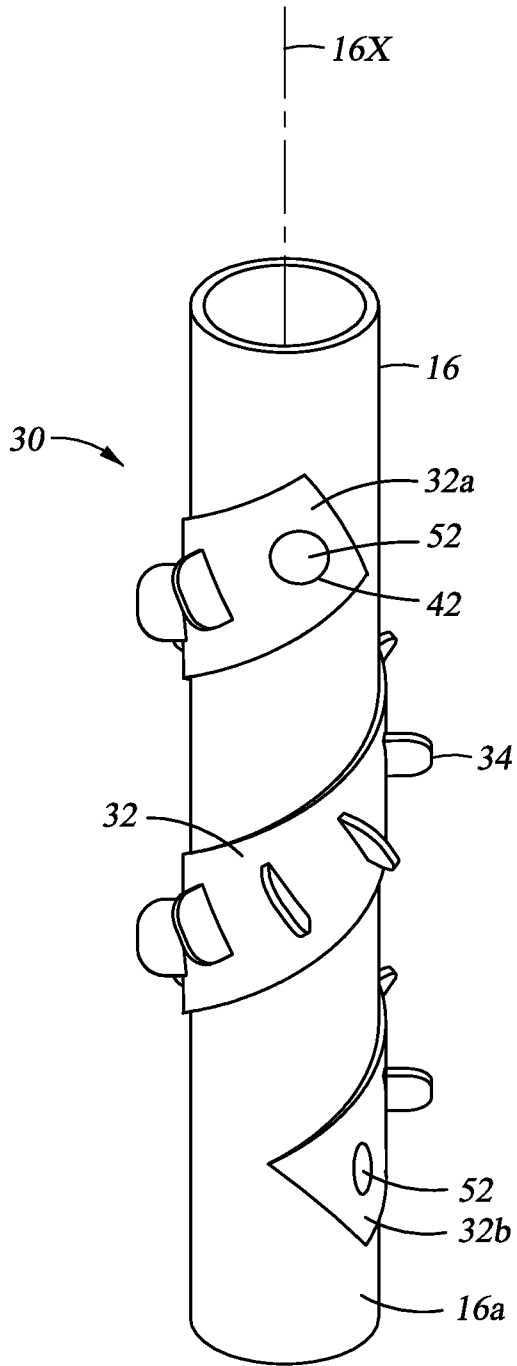

Fig. 6

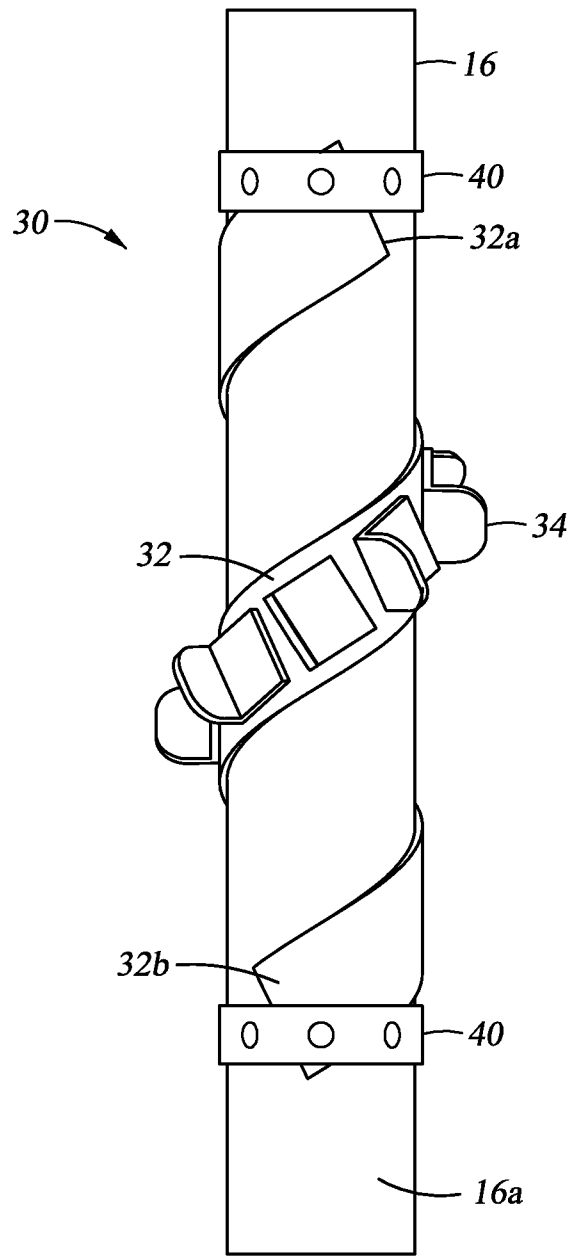

Fig. 7

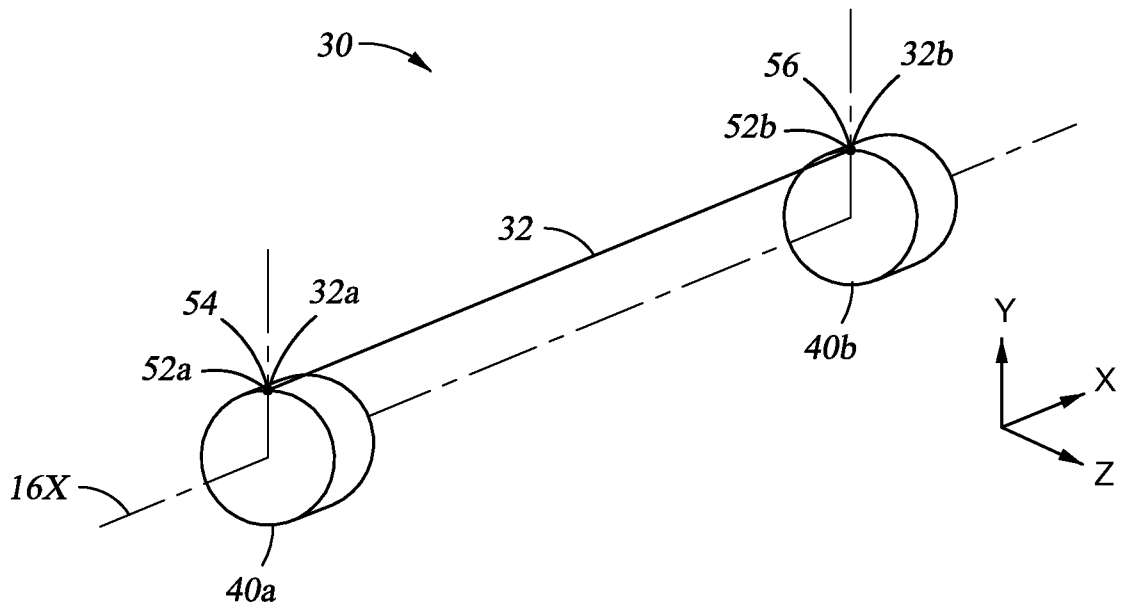

Fig. 8A

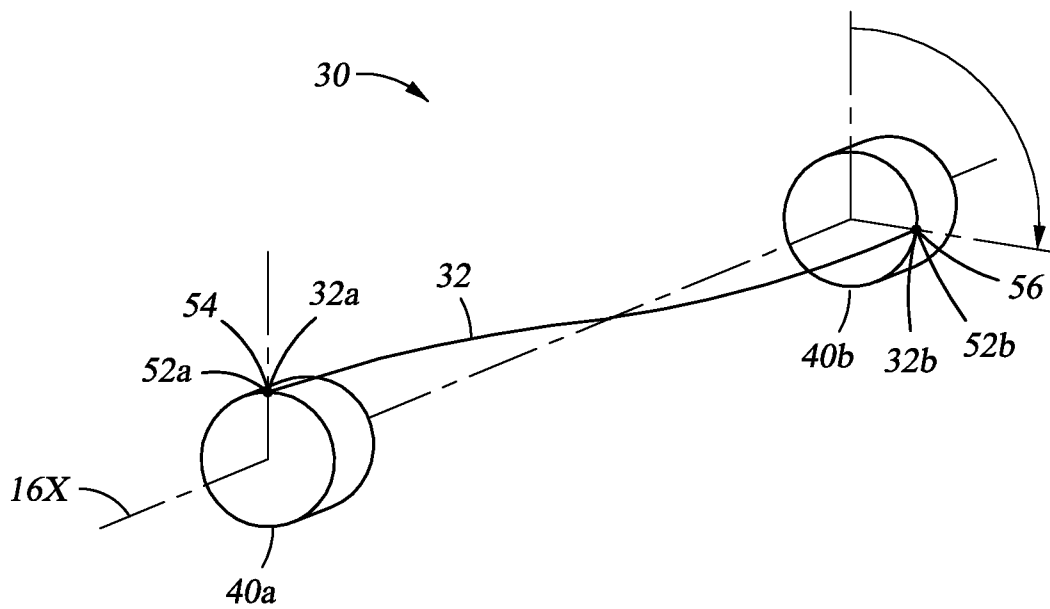

Fig. 8B

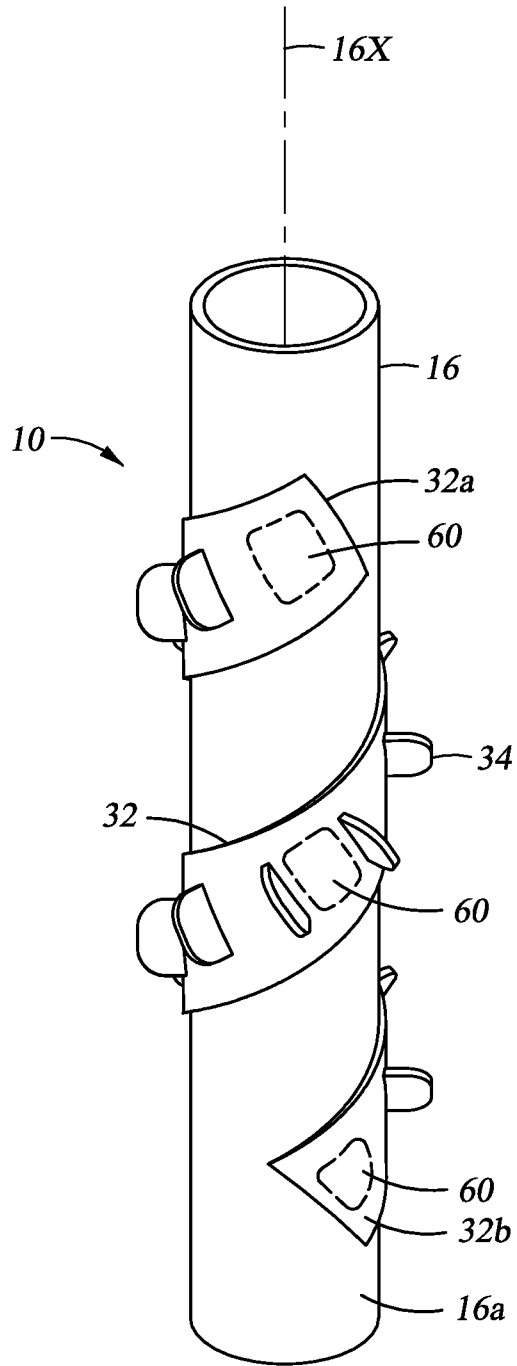

Fig. 9

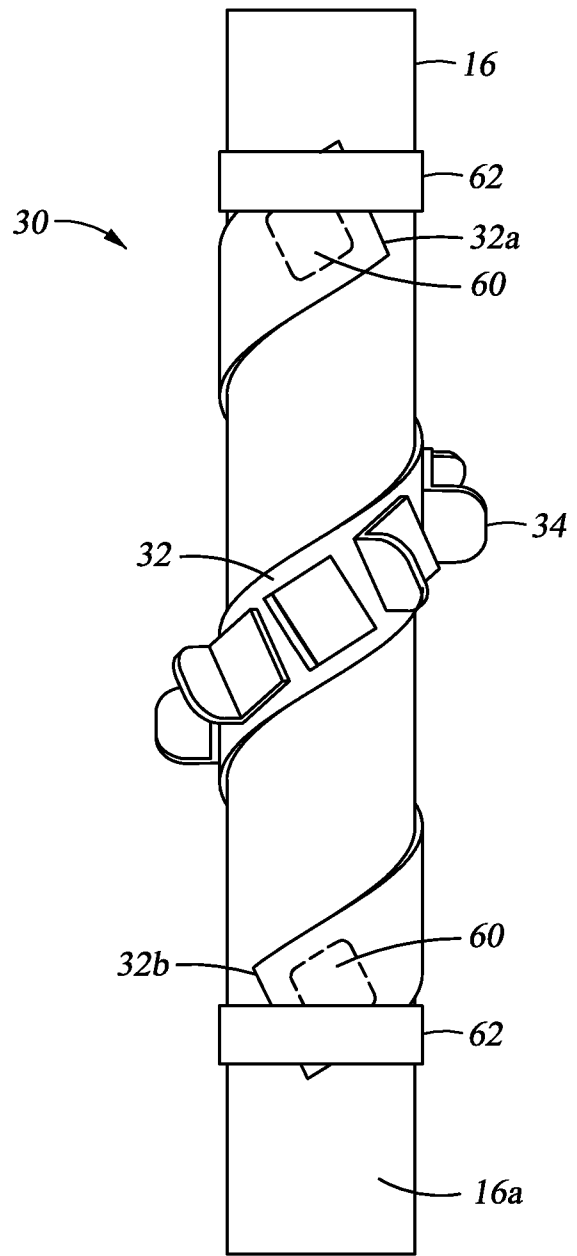

Fig. 10

INTERNATIONAL SEARCH REPORT

International application No.

PCT/US2011/024510

A. CLASSIFICATION OF SUBJECT MATTER IPC(8) - E21B 17/22 (2011.01) USPC - 166/241.6 According to International Patent Classification (IPC) or to both national classification and IPC																												
B. FIELDS SEARCHED Minimum documentation searched (classification system followed by classification symbols) IPC(8) - E21B 17/22 (2011.01) USPC - 166/241.6 Documentation searched other than minimum documentation to the extent that such documents are included in the fields searched IPC(8) - E21B 17/16 (2011.01) USPC - 166/241.7 Electronic data base consulted during the international search (name of data base and, where practicable, search terms used) MicroPatent, Google																												
C. DOCUMENTS CONSIDERED TO BE RELEVANT																												
<table border="1"> <thead> <tr> <th>Category*</th> <th>Citation of document, with indication, where appropriate, of the relevant passages</th> <th>Relevant to claim No.</th> </tr> </thead> <tbody> <tr> <td>X -- Y</td> <td>US 4,984,633 A (LANGER et al) 15 January 1991 (15.01.1991) entire document</td> <td>1, 11, 12, 16-18 ----- 2-10,13-15, 19-30</td> </tr> <tr> <td>Y</td> <td>US 4,818,888 A (LENOIR, III) 04 April 1989 (04.04.1989) entire document</td> <td>2, 3, 6, 7</td> </tr> <tr> <td>Y</td> <td>US RE 33,660 (JELSMA) 13 August 1991 (13.08.1991) entire document</td> <td>4-7, 14, 15, 19</td> </tr> <tr> <td>Y</td> <td>US 7,159,668 B2 (HERRERA) 09 January 2007 (09.01.2007) entire document</td> <td>9, 25, 28</td> </tr> <tr> <td>Y</td> <td>US 4,658,896 A (MILAM) 21 April 1987 (21.04.1987) entire document</td> <td>10, 13, 20, 30</td> </tr> <tr> <td>Y</td> <td>US 3,982,590 A (HARRIMAN) 28 September 1976 (28.09.1976) entire document</td> <td>8, 21-30</td> </tr> <tr> <td>Y</td> <td>US 2,537,797 A (SIMPELAAR) 09 January 1951 (09.01.1951) entire document</td> <td>22</td> </tr> <tr> <td>Y</td> <td>US 3,777,819 A (DELANO) 11 December 1973 (11.12.1973) entire document</td> <td>28</td> </tr> </tbody> </table>	Category*	Citation of document, with indication, where appropriate, of the relevant passages	Relevant to claim No.	X -- Y	US 4,984,633 A (LANGER et al) 15 January 1991 (15.01.1991) entire document	1, 11, 12, 16-18 ----- 2-10,13-15, 19-30	Y	US 4,818,888 A (LENOIR, III) 04 April 1989 (04.04.1989) entire document	2, 3, 6, 7	Y	US RE 33,660 (JELSMA) 13 August 1991 (13.08.1991) entire document	4-7, 14, 15, 19	Y	US 7,159,668 B2 (HERRERA) 09 January 2007 (09.01.2007) entire document	9, 25, 28	Y	US 4,658,896 A (MILAM) 21 April 1987 (21.04.1987) entire document	10, 13, 20, 30	Y	US 3,982,590 A (HARRIMAN) 28 September 1976 (28.09.1976) entire document	8, 21-30	Y	US 2,537,797 A (SIMPELAAR) 09 January 1951 (09.01.1951) entire document	22	Y	US 3,777,819 A (DELANO) 11 December 1973 (11.12.1973) entire document	28	<input type="checkbox"/> Further documents are listed in the continuation of Box C. <input type="checkbox"/>
Category*	Citation of document, with indication, where appropriate, of the relevant passages	Relevant to claim No.																										
X -- Y	US 4,984,633 A (LANGER et al) 15 January 1991 (15.01.1991) entire document	1, 11, 12, 16-18 ----- 2-10,13-15, 19-30																										
Y	US 4,818,888 A (LENOIR, III) 04 April 1989 (04.04.1989) entire document	2, 3, 6, 7																										
Y	US RE 33,660 (JELSMA) 13 August 1991 (13.08.1991) entire document	4-7, 14, 15, 19																										
Y	US 7,159,668 B2 (HERRERA) 09 January 2007 (09.01.2007) entire document	9, 25, 28																										
Y	US 4,658,896 A (MILAM) 21 April 1987 (21.04.1987) entire document	10, 13, 20, 30																										
Y	US 3,982,590 A (HARRIMAN) 28 September 1976 (28.09.1976) entire document	8, 21-30																										
Y	US 2,537,797 A (SIMPELAAR) 09 January 1951 (09.01.1951) entire document	22																										
Y	US 3,777,819 A (DELANO) 11 December 1973 (11.12.1973) entire document	28																										
<table border="0"> <tr> <td>* Special categories of cited documents:</td> <td>"T" later document published after the international filing date or priority date and not in conflict with the application but cited to understand the principle or theory underlying the invention</td> </tr> <tr> <td>"A" document defining the general state of the art which is not considered to be of particular relevance</td> <td>"X" document of particular relevance; the claimed invention cannot be considered novel or cannot be considered to involve an inventive step when the document is taken alone</td> </tr> <tr> <td>"E" earlier application or patent but published on or after the international filing date</td> <td>"Y" document of particular relevance; the claimed invention cannot be considered to involve an inventive step when the document is combined with one or more other such documents, such combination being obvious to a person skilled in the art</td> </tr> <tr> <td>"L" document which may throw doubts on priority claim(s) or which is cited to establish the publication date of another citation or other special reason (as specified)</td> <td>"&" document member of the same patent family</td> </tr> <tr> <td>"O" document referring to an oral disclosure, use, exhibition or other means</td> <td></td> </tr> <tr> <td>"P" document published prior to the international filing date but later than the priority date claimed</td> <td></td> </tr> </table>		* Special categories of cited documents:	"T" later document published after the international filing date or priority date and not in conflict with the application but cited to understand the principle or theory underlying the invention	"A" document defining the general state of the art which is not considered to be of particular relevance	"X" document of particular relevance; the claimed invention cannot be considered novel or cannot be considered to involve an inventive step when the document is taken alone	"E" earlier application or patent but published on or after the international filing date	"Y" document of particular relevance; the claimed invention cannot be considered to involve an inventive step when the document is combined with one or more other such documents, such combination being obvious to a person skilled in the art	"L" document which may throw doubts on priority claim(s) or which is cited to establish the publication date of another citation or other special reason (as specified)	"&" document member of the same patent family	"O" document referring to an oral disclosure, use, exhibition or other means		"P" document published prior to the international filing date but later than the priority date claimed																
* Special categories of cited documents:	"T" later document published after the international filing date or priority date and not in conflict with the application but cited to understand the principle or theory underlying the invention																											
"A" document defining the general state of the art which is not considered to be of particular relevance	"X" document of particular relevance; the claimed invention cannot be considered novel or cannot be considered to involve an inventive step when the document is taken alone																											
"E" earlier application or patent but published on or after the international filing date	"Y" document of particular relevance; the claimed invention cannot be considered to involve an inventive step when the document is combined with one or more other such documents, such combination being obvious to a person skilled in the art																											
"L" document which may throw doubts on priority claim(s) or which is cited to establish the publication date of another citation or other special reason (as specified)	"&" document member of the same patent family																											
"O" document referring to an oral disclosure, use, exhibition or other means																												
"P" document published prior to the international filing date but later than the priority date claimed																												
Date of the actual completion of the international search 24 March 2011	Date of mailing of the international search report 04 APR 2011																											
Name and mailing address of the ISA/US Mail Stop PCT, Attn: ISA/US, Commissioner for Patents P.O. Box 1450, Alexandria, Virginia 22313-1450 Facsimile No. 571-273-3201	Authorized officer: Blaine R. Copenheaver PCT Helpdesk: 571-272-4300 PCT OSP: 571-272-7774																											