

[54] CLIP MEANS FOR MOUNTING PLASTIC OR METAL FACING MATERIAL ON BUILDING BLOCK STRUCTURES

627,314 10/1961 Italy..... 52/630

[75] Inventor: Jack E. Gaston, Lancaster, Pa.

Primary Examiner—Ernest R. Purser
Assistant Examiner—William Randolph

[73] Assignee: Armstrong Cork Company, Lancaster, Pa.

[22] Filed: Dec. 10, 1973

[21] Appl. No.: 422,997

[52] U.S. Cl. 52/283; 52/478; 52/546; 52/562; 52/587

[51] Int. Cl.² E04B 1/00

[58] Field of Search 52/287, 288, 478, 546, 52/551, 568, 760

[57] ABSTRACT

Clips, adapted to be mounted in spaced relationship in the mortar joints of a block wall as it is being erected are described. The clips may each have a flat top portion with a depending front flange, an inwardly positioned depending flange having an outwardly extending edge, and a depending rear flange appropriately spaced away from the interior flange, to allow the rear portion of the clip to be hooked onto a building block with the interior flange in contact with the face thereof or, alternatively, the rear depending flange may be eliminated and the back portions of the tops of a plurality of clips may be attached to a mortar joint reinforcing member in appropriately spaced relationship.

Use of these clips in this manner enables standard or slightly modified facing material to be mounted in locked-in-place, overlapping relationship on the wall without requiring the use of other fastening means such as nails or screws.

[56] References Cited

UNITED STATES PATENTS

1,571,996	2/1926	Braddock.....	52/300
2,100,624	11/1937	Beckwith.....	52/760 X
2,490,663	12/1949	VanUum.....	52/509
3,405,485	10/1968	Edwards.....	52/300
3,651,610	3/1972	Donahue.....	52/546
3,730,466	5/1973	Swanquist.....	52/714

FOREIGN PATENTS OR APPLICATIONS

584,533	1/1947	United Kingdom.....	52/287
---------	--------	---------------------	--------

4 Claims, 9 Drawing Figures

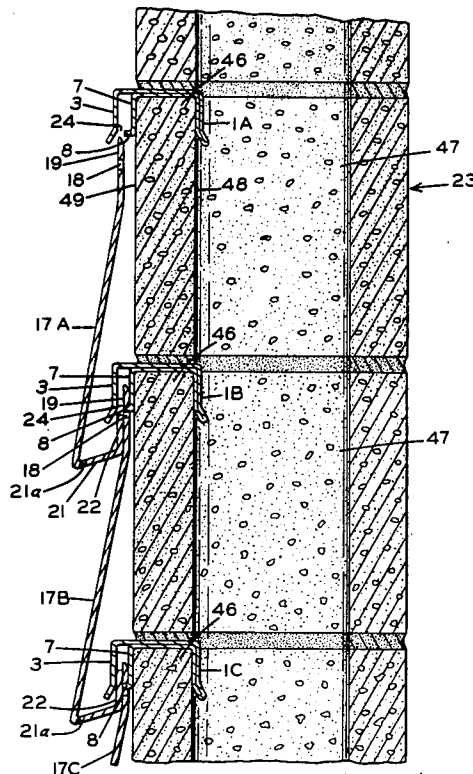

Fig. I

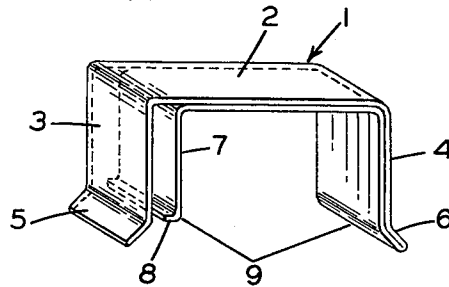

Fig. II

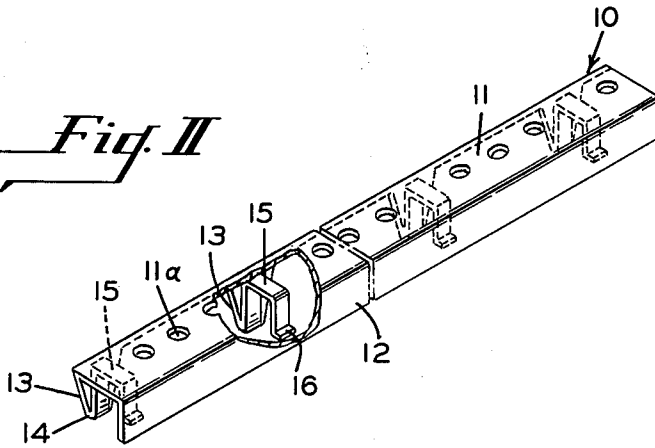

Fig. III

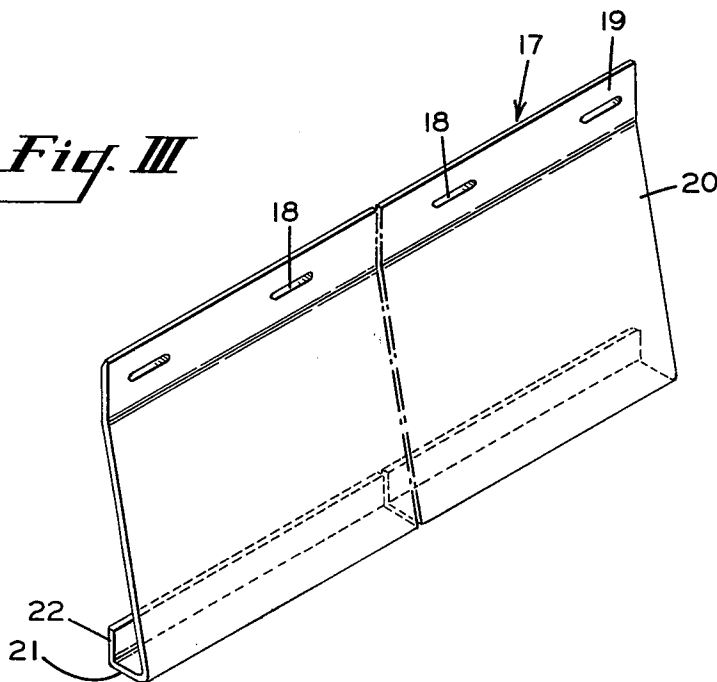

Fig. IV

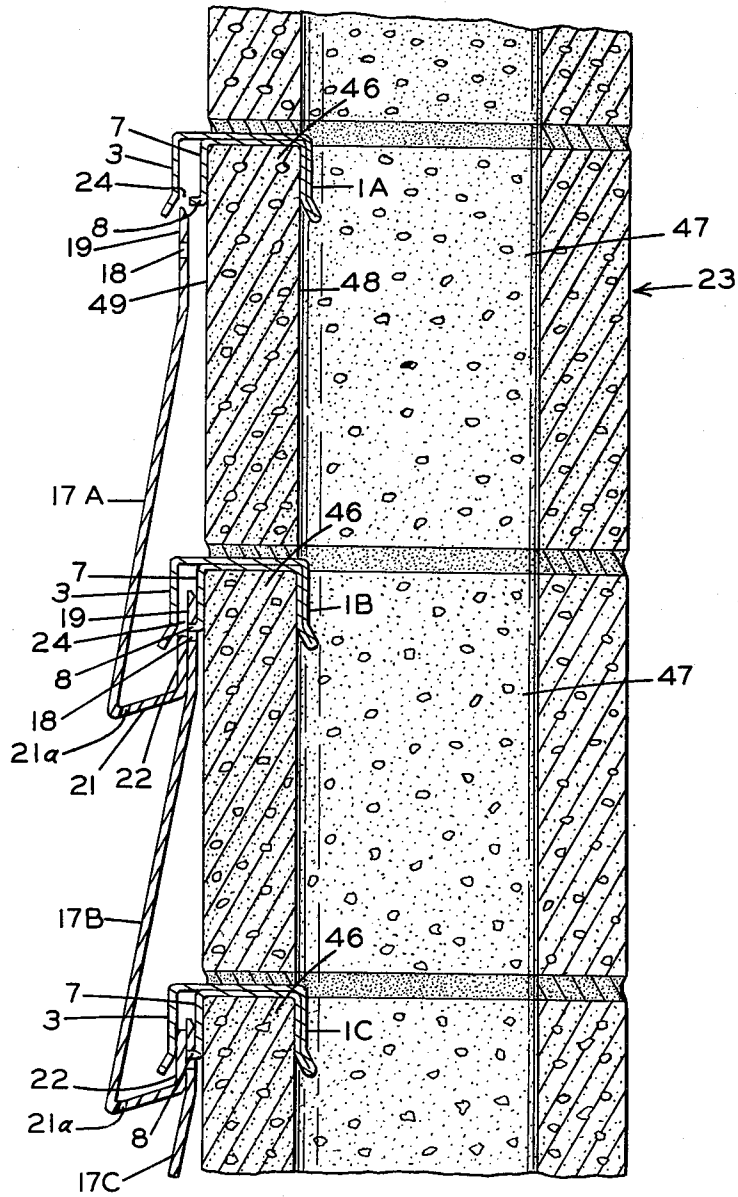

Fig. V

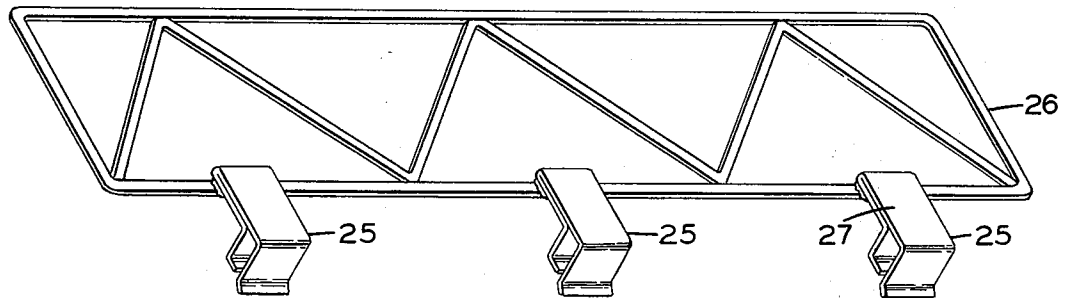
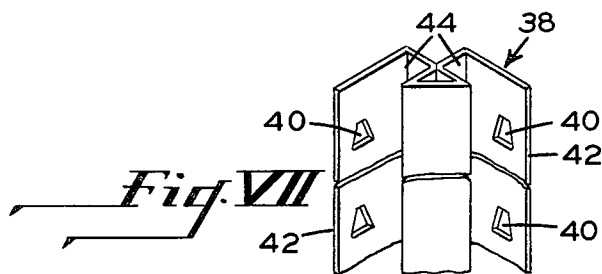
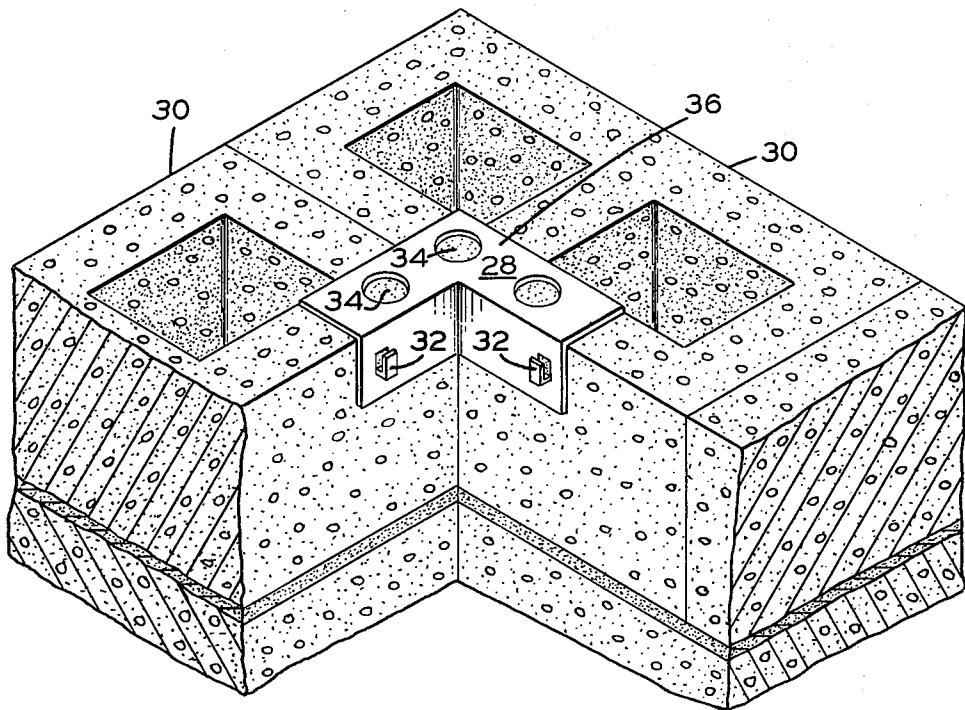

Fig. VI



CLIP MEANS FOR MOUNTING PLASTIC OR METAL FACING MATERIAL ON BUILDING BLOCK STRUCTURES

BACKGROUND OF THE INVENTION

1. Field of the Invention

The invention relates generally to clip means for applying plastic or metal facing material over building block structures. More specifically, this invention relates to clips which are adapted to be embedded in the mortar joints of a wall or the like as it is being erected to provide combined locking support and outward spacing and retention features for siding units mounted thereon.

2. Description of the Prior Art

The low cost, ease of construction and other practical benefits of concrete block structures have long been recognized. The aesthetic, outward appearance and weather-resistant qualities of such a structure, however, leaves much to be desired. Attempts to improve the outward appearance of such structures have included shaping the exterior faces of the blocks differently, incorporation of a separate decorative facing as the block was being pressed during the manufacture thereof, post-block formation application of a sprayed, dipped, or roller-applied plastic facing, and making the blocks wider at the base than at the top, so that when installed, the bottom front edge of the block would extend out over the top front edge of the next lower block to create a kind of clapboard siding effect. These methods, however, did not provide the weatherproof, aesthetically desirable features necessary to make such a structure readily acceptable for quality homes and other structures.

Lately, metal siding and plastic (usually poly vinyl chloride, normally termed "vinyl") siding have become well accepted as desirable exterior finishes for old or new frame houses. Erection techniques for these exterior surfacing materials, however, depend on having wooden studs or old but sound clapboard as a base. When installing these materials on masonry walls or old walls, furring strips are required or fastening elements must be driven into the walls.

Plastic and metal siding units are relatively thin and, even though they may be installed in overlapping relationship, if special mounting means are not used to achieve accentuated butt lines thereon, from a relatively short distance away the individual units are practically indistinguishable.

It is also desirable in the use of metal and plastic siding units to provide mounting means which are not only concealed, but which will readily allow movement of the siding due to thermal variations, to avoid buckling or bulging of the units between fastening means.

One prior method for providing a siding construction in which the siding units are made from relatively thin materials but in which the butt lines of the siding units are accentuated and deep shadow effects are obtained is disclosed in U.S. Pat. No. 2,740,166. In accordance with this invention, a spacer member is hooked over the top edge of a lower siding member and extends outwardly therefrom to space away the overlapping bottom edge of the next higher siding member through which a nail is driven above the spacing member to secure the siding to a base.

U.S. Pat. No. 3,458,962, while relating primarily to a means specifically designed to prevent a fastening

means therefor from being driven too hard into a supporting means, also discloses an overlapping and interlocked siding construction which employs thin plastic or metal materials and achieves an accentuated deep butt line effect.

U.S. Pat. No. 2,320,480 relates to a building structure, such as a wall, wherein specifically designed structural blocks are provided with face plates which are held flush with the front surface thereof by means of metal clips which are hooked onto the blocks at the location of one of the vertical holes therein. An inclined portion on each of the metal clips is received between similarly inclined top and bottom portions of adjacent face plates, and a stirrup-shaped bottom portion on each clip embraces a bottom portion of an upper face plate to lock it in position. This arrangement requires that the clips and face plates be installed on each row of blocks before the next row of blocks is laid due to the fact that if a clip-containing wall were assembled prior to installation of the face plates, the face plates could not be installed thereon. In the usual wall construction wherein conventionally shaped concrete blocks are laid with mortar between adjacent blocks, such a process would be extremely impractical, costly, and time-consuming. In addition, a wall structure is obtained wherein portions of the clips are visible, and wherein there is no accentuation of the butt line of the facing.

SUMMARY OF THE INVENTION

This invention relates to improved clip means that are adapted to be embedded in the mortar joints of a block wall structure as it is being constructed. By use of the improved clip means of this invention, plastic or thin metal siding courses may subsequently be mounted and secured on a building block structure in locked-in-place, overlapping relationship with the butt edges thereof spaced outwardly from the wall to provide the depth and shadow appearance normally associated with the outward appearance of a more expensive wood, metal or vinyl-surfaced residential structure.

The clips of this invention may be provided as individual pieces or as a strip of several clips properly spaced and attached to a length of heavy wire or a light strip of metal. They may also be formed as an integral part of an elongated metal panel, or the clips may be provided as an attachment to mesh or other "shaped wire" or thin metal mortar joint reinforcement strips.

In its simplest form, this invention comprises a metal clip in the general shape of a flat-topped inverted U with an interior depending tab or flange having an outwardly extending edge portion. The clips are primarily adapted for use in mounting thin metal or plastic siding on masonry building blocks having vertical openings spaced a predetermined distance from their faces. However, by merely increasing appropriately the distance between the rear flange and the depending interiorly positioned flange, or by utilizing one of the modifications of the clip means of this invention, the clips may be used to similarly mount the siding on building blocks which may or may not have vertical openings therein. For example, the rear depending flange of the above-described clip may be eliminated and the clip mounted on the wall by either carefully embedding the rear of the top portion of the clip in a mortar joint thereof or by mounting the rear portions of a number of clips in properly spaced relationship on a mortar joint reinforcing member prior to its installation in a mortar joint. The latter arrangement would allow the installa-

tion of a plurality of clips on the wall simultaneously. It is further obvious that, although the clip means of this invention is primarily adapted for use in the mortar joints of structures formed of building blocks, the clips may be modified for use on other than block structures and/or used on block structures by mounting them thereon in a manner not involving their installation in the mortar joints. For example, by eliminating the depending rear flange of the clip and bending the back top portion up or down into vertical alignment with the interior depending flange, the clip could then be mounted on a wall by known fastening means such as nails, screws, etc.

In using the generally inverted U-shaped clips with the interior depending flange, in connection with the usual concrete building block structures, the clips are snapped or hooked onto the upper edge portions of the face of the blocks at the location of the vertical holes therein with the rear flange of the clip in engagement with the adjacent inner wall of the opening in the block and with the interior depending tab or flange of the clip in engagement with the outer face of the block, whereby, a friction-fit is obtained which prevents dislodgment of the clips when covering blocks are put into place. One clip per block is installed in the same position on each block and provides uniformly spaced top and bottom anchoring points for plastic or metal siding along the length of the wall at each mortar line. The outwardly extending edge of the interior depending tab or flange is adapted to be inserted in one of a longitudinal series of elongated spaced openings provided in the top portion of a siding member having a rearwardly-facing hook-shaped butt portion, to support the member on the tab or flange edge. The front flange of the flat topped inverted U-shaped clip is positioned outwardly in spaced relation to the outwardly extending edge portion of the interior depending tab and the space therebetween is adapted to receive the upturned flange of the rearwardly-facing, hook-shaped butt portion of a next higher siding member, secure it against in-and-out movement with respect to the wall, and hold it in overlapped relationship to the top portion of the lower panel, thereby locking the top portion of the next lower siding member on the edge of the interior depending flange.

In using another embodiment of the clip means of this invention wherein a series of modified clips are attached in properly spaced relationship to a mortar joint reinforcing member, the joint reinforcing member and the rear portion of the clips attached thereto are embedded in the horizontal mortar joints between each horizontal row of blocks as the wall is being constructed. The portions of the clips protruding from the mortar joints will then operate in the same manner and for the same purpose as previously described in connection with the individual clips. In addition to the obvious advantage of the mortar joint reinforcing member, this embodiment enables a plurality of properly spaced clips to be mounted on a structure simultaneously.

The primary object of this invention is to provide a simple and effective clip means which will make possible the erection of a relatively inexpensive exterior for block structures which in turn will result in an outward appearance hardly discernible from that of wood clapboard siding.

The present invention is an improvement over prior siding mounting means in that, by this invention a hid-

den clip means is provided for mounting thin metal or plastic siding on building block structures, whereby, no furring strips or nailing is required; a complete clip-containing wall may be constructed prior to installation of the siding; the clip structure and the top edge of a siding panel mounted thereon coact with the upstanding flange of the butt portion of a next higher, overlapping siding panel to provide the panels with a supporting, spacing and locking arrangement; conventionally shaped concrete blocks may be used for the wall structure; buckling due to thermal variations is avoided; and, the outward desirable appearance of wood clapboard siding, or other acceptable surfacing, such as shingles or shakes, is achieved.

The present invention will be more fully understood and the objects and advantages thereof will become apparent when reference is made to the more detailed description of the preferred embodiment of the invention which follows and through the accompanying drawings in which:

BRIEF DESCRIPTION OF THE DRAWINGS

FIG. I is an oblique view of one of the individual clips of this invention;

FIG. II is an isometric view showing another embodiment of the clip structure of this invention (with the central portion broken away) wherein a spaced series of integral clip portions are formed on the rear portion of an elongated, rectangularly shaped panel having a vertically depending front flange;

FIG. III is an isometric view of a siding panel (with the central portion broken away) adapted to be used in conjunction with the clip structure of this invention;

FIG. IV is a sectional view of a portion of a block wall with clips in place thereon; facing panels mounted in locked overlapping relationship thereon; and, a panel in position just prior to being mounted on the clips;

FIG. V is an isometric view showing a series of properly spaced modified clips of this invention mounted on a mortar joint reinforcing member;

FIG. VI is an isometric view, partially in section, of a portion of an inside corner of a block wall with corner clips mounted thereon;

FIG. VII is an isometric view, partially broken away, of a corner trim strip adapted to be mounted on the inside corner clips shown in FIG. VI;

FIG. VIII is an isometric view of a portion of an outside corner of a block wall with corner clips mounted thereon; and

FIG. IX is an isometric view, partially broken away, of an outside corner trim strip adapted to be mounted on the clips shown in FIG. VIII.

DESCRIPTION OF THE PREFERRED EMBODIMENT

Referring to the drawings, there is shown in FIG. I a clip 1, which is preferably formed from sheet metal into the general shape of an inverted U having a flat, rectangularly shaped top portion 2, vertically depending front and rear flange portions 3 and 4 having lip or edge portions 5 and 6, respectively, extending outwardly and downwardly therefrom, and an interiorly positioned depending flange 7 having a horizontal edge portion 8 which extends outwardly a distance about equal to the thickness of the siding to be mounted thereon. As shown in FIG. I, the interior flange 7 with its horizontal edge portion 8 may be formed as an integral part of the clip 1 by bending a continuation of the rear flange 4

5

back upon itself, then outwardly in parallel contacting relationship with the top portion 2 and then downwardly at right angles thereto and outwardly at right angles to form the edge portion 8. It will be understood, however, that the interior flange 7 with edge portion 8 may be formed as a separate piece and then attached to the inner surface of the clip 1 as by welding, for example, in which case the inner bent-back portions of the clip would be eliminated.

Interior flange 7 is positioned away from rear flange 4 a distance predetermined to provide a good friction fit when the hook-shaped portion 9 of the clip 1 is fitted over the outer wall thickness of a building block with the rear flange 4 inserted into one of the cavities thereof in contact with the adjacent inner wall surface. The dimensions of this space will be different for the various types of blocks such as concrete blocks, ceramic tile blocks, terra-cotta tile, or for different widths of concrete blocks (4-inch, 8-inch, 12-inch, etc.). Clips may be made to fit each type of block. The lip or edge portions 5 and 6 on front and rear flanges 3 and 4 of clip 1 make installation of the clips easier but they are not an absolute requirement. Edge portion 8 of flange 7 extends outwardly in an amount about equal to the thickness of the siding to be mounted thereon and is also located in properly spaced relation to the inner surface of front flange 3 to allow the top edge of a panel having fastener-receiving apertures therein to be inserted therebetween and hooked onto the edge 8, the remaining space between edge 8 and the inner surface of flange 3 being adapted to receive the upstanding flange of a hook-shaped butt edge of a panel of a next higher course thereby locking the first panel on the edge portion 8 of flange 7 with the butt edge of the upper panel being held in contacting, overlapping relation to the first panel by means of the flange 3.

The embodiment of the clip structure 10 as shown by FIG. II comprises an elongated panel having a flat, rectangularly shaped top surface 11 with openings 11a therein to provide better anchoring in a mortar joint, an integral vertically depending front flange 12 and integral multiple spaced vertically depending back flange portions 13 having reduced-in-width portions 14, each being bent inwardly and back upon itself and formed into a hook or stirrup-shaped portion 15 having an outwardly extending horizontal edge portion 16 terminating in spaced relation to the inner surface of the front flange 12. This structure makes it possible to mount a plurality of clips on a wall structure simultaneously in properly spaced relationship and, in addition, provides increased support for facing panels mounted on the clips along the lengths thereof while holding them firmly in spaced, overlapping relation with the wall and the top portion of a next lower course of panels mounted on the edge portions 16 of clip structure 10.

One form of siding adapted to be used in conjunction with the clip means of this invention, as shown in FIG. III of the drawings, comprises a thin metal or plastic panel 17 having a series of spaced, horizontally aligned fastener receiving openings 18 in the vertical top edge portion 19 thereof. It is important that openings 18 be greater in length than edges 8 of clips 1 are wide to provide for dimensional change of the panels with temperature and to reduce the precision required in mounting the clips. The main body portion 20 of the panel 17 extends downwardly and outwardly at a slight angle to the vertical top portion 19 and terminates in a butt edge having a rearwardly-facing hook portion 21 with an up-

6

standing flange 22 thereon. These panels may be smooth and plain (in various colors) on the exposed face or embossed with wood grain, shake or shingle patterns, or other design effects, also in color if desired.

FIG. IV illustrates the manner in which a clip structure such as that shown in FIG. I may be mounted on a conventional concrete block wall 23 to support thin metal or plastic siding panels 17 A, B and C in locked, overlapping relationship thereon. As shown in this view, a facing panel 17C is mounted on the horizontal edge portion 8 of the interior depending flange 7 of the lowermost clip 1C. Panel 17C is locked in place on edge 8 of flange 7 of clip 1C by means of the upstanding flange 22 of the next higher panel 17B which is positioned between the edge 8 of flange 7 and the inner surface of depending front flange 3 of clip 1C. Edge portion 8 of the interior flange 7 of the next higher clip 1B supports the vertical top portion 19 of panel 17B by being inserted in the opening 18 therein. Panel 17A is shown just prior to being clipped into place with the top 19 of the panel about to enter the space 24 between flange 3 and edge 8 of interiorly depending flange 7 of clip 1A so that the fastener receiving opening 18 may be placed over the edge 8 of interiorly depending flange 7 of the clip 1A. With the same upward motion, the upstanding vertical flange 22 of the hook portion 21 of panel 17A will be pressed into the space 24 between flange 3 and edge 8 of the interiorly depending flange 7 of clip 1B to anchor the top of panel 17B and the bottom of panel 17A in place. Drainage openings 21a may be provided in hook-shaped butt edge 21 of the facing panels to allow escape of any moisture that may accumulate on their inner surfaces.

Advantageously, the metal or plastic facing members may be mounted on the block wall structure by utilizing a combination of the modified clip structure 25 and mortar joint reinforcing member 26 as shown in FIG. V. The modified clip structure 25 of FIG. V is identical with that of the clip 1 as shown in FIG. I except that the back flange 4 of clip 1 has been eliminated and the rearwardly extending portion 27 of the clip 25 is secured to the front portion of the mortar joint reinforcing member 26. The mortar joint reinforcing member 26 may be made of shaped wire, mesh, thin metal, or the like. A series of the clips 25 would be mounted in properly spaced relationship on the mortar joint reinforcing member 26 as shown, thus enabling a number of clips to be mounted on the blocks simultaneously.

When using the herein described system for covering block walls, it is necessary to provide another type of special clip in every second or third course of blocks at the inside and outside corners to support the corner trim strips. Special corner clips 28 and 29 are shown in FIGS. VI and VIII of the drawings. As shown in FIGS. VI and VIII, corner clips 28 and 29 are mounted on the corner blocks 30 and 31 and will be embedded in the mortar joints of the wall at the inside and outside corners thereof to provide hook elements 32 and 33 every 16 inches or 24 inches along the vertical distance of such corners. Openings 34 and 35 are provided in the flat top surface 36 and 37 of each of the members 28 and 29 to allow mortar to pass therethrough and thus provide better anchoring of the clips 28 and 29 in the mortar joints.

FIGS. VII and IX show corner trim units 38 and 39 having fastener receiving apertures 40 and 41 in flanges 42 and 43, respectively, thereof. The apertures 40 and 41 in flanges 42 and 43 of the corner trim units 38 and

39 are adapted to fit over hook elements 32 and 33 on corner clips 28 and 29. Spaces 44 and 45 are provided in corner trim units 38 and 39 into which the ends of facing panels 17 are fitted when the corners are reached. The corner trim units 38 and 39 are installed

prior to the installation of facing strips 17. In constructing a block wall having an outer facing of thin metal or plastic panels 17 mounted thereon in locked and overlapping relationship by means of a plurality of appropriately placed and spaced clips 1, after a conventional block foundation has been formed, and if individual clips are used, the hook-shaped portion 9 of the clip 1 (FIG. I) is hooked over the top front edge portion 46 (FIG. IV) of each of the blocks of a first horizontal course of the blocks of the block wall 23 with back flange portion 4 of clip 1 extending into the opening 47 of the blocks of wall 23 and in contact with adjacent inner wall surface 48 of the opening 47. Interiorly depending flange 7 of clip 1 will then lie in contact with the outer face 49 of the block wall 23 and horizontal edge 8 on interior flange 7 extends outwardly therefrom and terminates in spaced relation to the inner surface of front flange 3. Mortar is then applied to the top surface of each of the first horizontal course of blocks of the wall 23 and flat top portion 2 of each clip 1. Corner clips 28 and 29 for the inside and outside corners are fitted in place as the wall is built; however, they are installed at the corners only every second or third row of blocks to provide 16-inch or 24-inch spacing vertically between the anchoring points. A second row of blocks is then laid onto the first row having a plurality of the clips embedded in the mortar thereon and the process above described is repeated to form the clip-containing block wall.

When the walls are ready for the installation of the siding, the corner trim units 38 or 39 (depending on whether an inside of outside corner is involved) are put into place first. The siding panels 17 are then installed by starting at an inside or outside corner of the lowest row of blocks to be covered, and the end of the first of the panels 17 is properly fitted into the space 44 or 45 of trim units 38 or 39. Panel 17 is then installed on the clips mounted on the wall by placing the top edge 19 of panel 17 in the space between the horizontal edge portion 8 of the interior depending flange 7 and the inner surface of depending front flange 3 of clip 1 mounted in the mortar joint at the top of the row of blocks to be covered. At the same time, the upstanding flange 22 of the butt edge portion 21 of the panel 17 is placed in the space 24 between the horizontal edge portion 8 of the interior depending flange 7 and the inner surface of depending front flange 3 of a clip located in the mortar joint at the bottom of the lowest row of blocks to be covered. The panel 17 is then pushed upwardly to hook the openings 18 in the top edge 19 thereof onto the edge 8 of interior flange 7. This upward movement of panel 17 simultaneously moves upstanding flange 22 of the butt portion 21 of panel 17 into position between the edge 8 of interior flange 7 and the depending front flange 3 of the clip mounted in the mortar joint at the bottom of the row of blocks being covered.

The next panel in the horizontal row of panels is mounted on the clips in a similar manner. Upon reaching the next corner, the last panel in the horizontal row is cut to the proper length and installed using the same procedure as that used to install the first panel.

A next higher row or course of panels would be installed in the manner just described. The upstanding

flange 22 of the butt portion 21 of a panel 17 of an upper course of panels would then, being positioned between the edge 8 of interior flange 7, with the top edge 19 of a next lower panel mounted thereon, and the inner surface of front flange 3 of the clip, serve to lock the top edge of the lower panel on the edge 8 of flange 7 of the clip. By this arrangement, the butt portion 21 of panel 17 is thus held firmly in overlapped relation to the mortar lines of the blocks and to the top and bottom portions of upper and lower panels and, the butt portion of each panel is held against any in-and-out movement, and in spaced-away relation to the block structure, thereby creating a weatherproof wall facing on a concrete block structure which has the appearance of a wood siding exterior such as that used on much more costly conventionally constructed residential houses, garages, and the like. The metal or plastic facing material used may be made from thin sheets of such material shaped to resemble wood ship-lapped siding (or shakes or shingles) and similar to such facing units now on the market, modified where necessary, to incorporate the special slots, flanges, and other features of such units as described in the specification.

The paneled wall structure constructed according to this invention is simple to erect, speedy in construction, because the entire clip-containing wall can be erected prior to installing the paneling, and installation of the paneling itself does not require any expertise to achieve an outstanding job in appearance as well as durability and weatherproofing.

What is claimed is:

1. A facing means for walls of a building structure comprising in combination, a plurality of clips mounted in spaced relation on a wall, each of said clips having a flat top portion extending outwardly from said wall, means integral with and extending from the rear of said top portion adapted to be fastened to said wall, a front flange depending vertically from said top portion in spaced relation to said wall, and at least one depending wall-contacting flange positioned inwardly from said front flange and having an outwardly extending edge portion which terminates in spaced relation to said front flange, a plurality of thin material siding panels mounted on said clips, each of said siding panels having a substantially vertical top edge portion with horizontally aligned, elongated, spaced fastener apertures therein, a main body portion extending downwardly and outwardly at a slight angle from said top portion and a rearwardly facing hook-shaped butt edge portion which terminates in an upstanding flange, said siding panels being mounted on said clips by means of the fastener apertures in the top edge of a siding panel being positioned over the outwardly extending edge of the inwardly positioned flanges of the clips, said upstanding flange of the hook-shaped butt edge portion of a next higher course of panels being positioned in the space between said top edge of a siding panel mounted on said outwardly extending edges of the inwardly positioned flanges of the clips and the inner surface of the front flanges thereof whereby said front flange, and the outwardly extending edge of the inwardly positioned flange of the clip, the top edge of a siding panel mounted thereon and the upstanding flange of the butt portion of a next higher panel coact to hold the siding panels in locked-in-place, overlapped relation on the wall.

2. A facing means for walls of a building structure according to claim 1 wherein said walls are formed of

9

building blocks and said facing means includes a plurality of corner clips mounted in vertically-aligned, spaced relation in the mortar joints between upper and lower courses of blocks of an inside corner of said building structure, each of said clips comprising two metal pieces, each having a flat top surface and a flat side surface extending at right angles to each other, said two metal pieces being joined to have an included angle of 90° between said flat side surfaces, each of said flat side surfaces having at least one lug struck outwardly therefrom adjacent the outer edge thereof, trim means adapted to be mounted on said corner clips to receive the ends of siding panels mounted on said wall and provide a decorative finish to the wall facing means.

3. A facing means for walls of a building structure according to claim 2 wherein said walls are formed of building blocks and said facing means includes a plurality of corner clips mounted in vertically-aligned, spaced relation in the mortar joints between upper and lower courses of blocks of an outside corner of said building structure, each of said clips comprising two metal pieces, each having a flat top surface and a flat side surface extending at right angles to each other, said two metal pieces being joined to have an included angle of 270° between said flat side surfaces, each of said flat side surfaces having at least one lug struck outwardly therefrom adjacent the outer edge thereof, trim means adapted to be mounted on said corner clips to receive

10

the ends of siding panels mounted on said wall and provide a decorative finish to the wall facing means.

4. In combination, clip and mortar joint reinforcing means for mounting overlapping, thin siding members having fastener-receiving openings in their top edge portions and also having rearwardly facing hook-shaped butt edges, on a wall structure formed of building blocks, said means comprising:

- a. a plurality of clips, each having a substantially flat top portion with front and rear edges;
- b. a first flange integral with and extending vertically downward from the front edge of the top portion of each of the clips;
- c. a second flange depending vertically from the top portion of each of the clips and positioned rearwardly in spaced relation to said first flange, said second flange having a forwardly extending edge portion directed toward said front flange and terminating in spaced relation thereto;
- d. A substantially flat elongated rectangularly shaped mortar joint reinforcing member having a longitudinal front edge portion, the rear edges of the plurality of clips being mounted in longitudinally spaced relation to each other on the front edge portion of said mortar joint reinforcing member, whereby, a plurality of clips can be simultaneously mounted in properly spaced relation in a mortar joint of a block wall structure.

* * * * *

5

10

15

20

25

30

35

40

45

50

55

60

65

UNITED STATES PATENT OFFICE
CERTIFICATE OF CORRECTION

PATENT NO. : 3,918,227
DATED : November 11, 1975
INVENTOR(S) : Jack E. Gaston

It is certified that error appears in the above-identified patent and that said Letters Patent are hereby corrected as shown below:

Column 9, line 17, the words "claim 2" should read --claim 1--.

Signed and Sealed this

twenty-third Day of March 1976

[SEAL]

Attest:

RUTH C. MASON
Attesting Officer

C. MARSHALL DANN
Commissioner of Patents and Trademarks