

M. A. ZÜRCHER.
RAILWAY CAR.

No. 405,292.

Patented June 18, 1889.

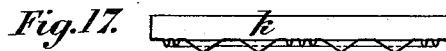
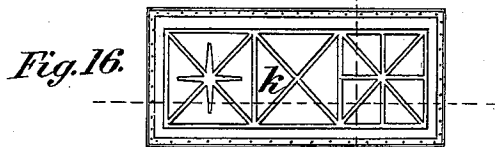
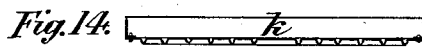
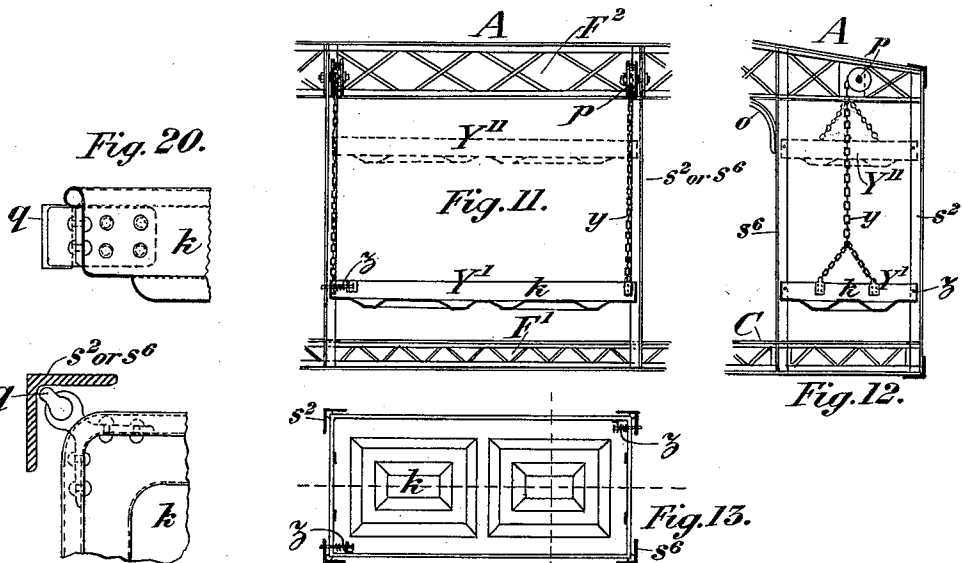
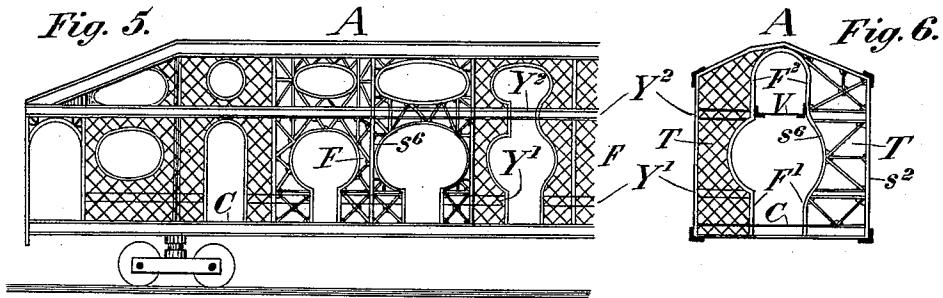

Witnesses.

L. V. Hawwood
A. E. McKechnie

Inventor.

Max A. Zürcher
By his Attorneys

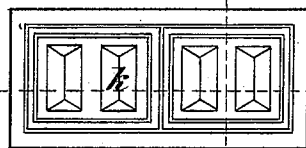

Fig. 19.

Wiedersheim & Kintner

(No Model.)

3 Sheets—Sheet 3.

M. A. ZÜRCHER.
RAILWAY CAR.

No. 405,292.

Patented June 18, 1889.

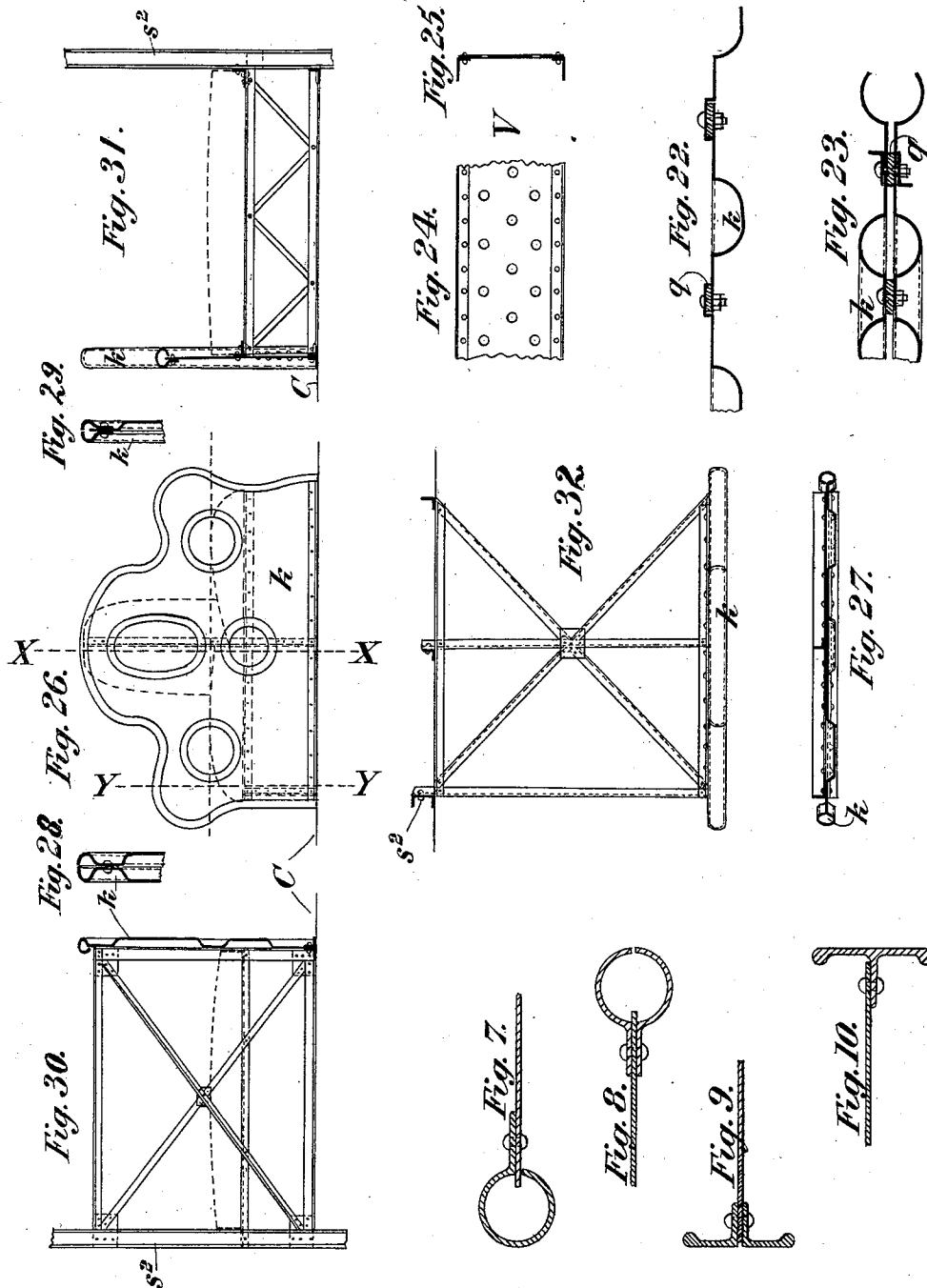

Witnesses.

L. V. Harwood
A. E. McKeehuir

Inventor.

Max A. Zürcher
By his Attorneys
Wiedersheim & Kintner

UNITED STATES PATENT OFFICE.

MAX A. ZÜRCHER, OF MONTREAL, CANADA.

RAILWAY-CAR.

SPECIFICATION forming part of Letters Patent No. 405,292, dated June 18, 1889.

Application filed March 16, 1889. Serial No. 303,592. (No model.)

To all whom it may concern:

Be it known that I, MAX A. ZÜRCHER, a citizen of the United States, temporarily residing at Montreal, in the Province of Quebec and Dominion of Canada, have invented a new and useful Improvement in Railway-Cars, of which the following is a specification.

My invention relates particularly to improvements in the frame-work and interior construction of what is known in the art as "sleeping and passenger railway-cars," and is directed to improvements upon the statically-constructed cars disclosed by me in a prior patent granted by the United States on the 5th day of June, 1888, and bearing No. 384,225, and certain improvements thereon disclosed in applications filed by me on the 25th day of May, 1888, Serial No. 275,121, and the 6th day of July, 1888, Serial No. 279,221, and the 21st day of July, 1888, Serial No. 280,671. In the aforesaid patent and prior applications I have disclosed and claimed specific forms of statically-constructed railway-cars having increased strength and various other advantages, particularly pointed out in said patent and applications.

The present application relates, therefore, to the adaptation of such specially-constructed forms of car-frames to passenger traffic and to certain details of construction, hereinafter pointed out, whereby I am enabled to devise a car for traffic of this nature which has special advantages in point of strength, comfort, and carrying capacity.

The objects of the present invention are, first, to provide a statically-constructed car-frame with interior statically-constructed compartments adapted to maintain sleeping-berths in vertical tiers, the sustaining-frames for said sleeping-berths being integrally connected to the statically-constructed framework of the car or forming part or parts thereof, thereby giving increased strength; second, to devise a statically-constructed sleeping-car which shall have tiers of berths arranged vertically above each other, in combination with an elevated passage-way affording easy access to the upper row or rows of berths; third, to devise simple and efficient means for elevating and lowering the berths in their respective compartments; fourth, to give increased carrying capacity for sleeping-cars by

providing an increased number of sleeping-berths and means of access thereto, and, fifth, to make cars of this nature absolutely fire-proof and of such material as shall also give increased strength and security. I accomplish these objects by the construction and arrangements hereinafter described, but particularly pointed out in the claims which follow this specification.

My invention will be better understood by referring to the accompanying drawings, in which like letters of reference represent like parts wherever used.

Figure 1 represents a longitudinal vertical section of a part of one of my improved cars having increased central depth. Figs. 2 and 3 represent vertical transverse sections taken through Fig. 1, and Fig. 4 represents a sectional horizontal plan view of the interior lateral trusses used in the construction of the passage-way V and fixed-berth framework. Fig. 5 represents a vertical longitudinal sectional view similar to Fig. 1 of a part of a car constructed in accordance with my improvements, but without the increased central depth shown in Fig. 1. Fig. 6 represents a vertical transverse section taken through Fig. 5. Figs. 7, 8, 9, and 10 are detail views showing the forms of construction of the interior girder-work, having rounded corners to avoid the objectionable features of sharp or angular corners in the interior of the car. Fig. 11 is a detail longitudinal sectional view taken through one of the berth-apartments, and Fig. 12 is a partial transverse vertical section of the same. Figs. 13, 16, and 19 are plan views of one of the berths, showing in the first instance the corner sustaining-posts s^2 and s^6 thereof; and Figs. 14 and 17 are vertical longitudinal sections of the berth, while Figs. 15 and 18 are transverse sections of said berth. Figs. 20 and 21 are detail views of a corner of one of the berths, showing also the sustaining frame or posts therefor in section for the latter figure. Fig. 22 is a sectional view showing various connections of single-paneled plate; Fig. 23, the same for double-paneled plate. Fig. 24 is a partial plan view of the overhead passage-way V for affording access to the overhead berths, while Fig. 25 is a transverse sectional view thereof. Fig. 26 is an elevational view of the framework

of a pair of seats located back to back in the usual manner in cars of this nature, being of paneled plate. Fig. 27 is a sectional plan view of Fig. 26. Fig. 28 is a sectional transverse view of same, while Figs. 29 and 30 are similar views of different flange details; besides, the latter figure shows the transverse bracing at the back of the seats on the line X X of Fig. 26. Fig. 31 shows the transverse bracing on the line Y Y when used. Fig. 32 is a plan view of the same, showing the horizontal bracing under the seat-cushions.

A represents a car of either uniform or variable depth, having the general statical construction of frame-work disclosed in my prior patent and applications heretofore referred to.

F¹, F², F³, and F⁴ represent the interior longitudinal vertical girders, trusses, or struts extending the entire length or a portion thereof of the car and connected integrally with interior transverse trusses T, in the manner disclosed in said prior patent and applications.

The above-specified interior trusses F¹, F², F³, F⁴, and especially T, divide the car into sections substantially equal to the length of the sleeping-berths, as shown at 1 1, Fig. 4. These sleeping-berths Y¹, Y² and Y³ are arranged in tiers, as shown in Figs. 1, 2, 3, 5, 6, 11, and 12, above which there are means adapted to hoist or elevate them bodily, as clearly shown in Figs. 11 and 12. The shells of the berths Y¹, &c., holding the bedding are preferably provided with wire rope *y*, attached to their ends, as shown in Figs. 11, 12, and 13, and connected with mechanism *p*, located overhead for raising and lowering them into position, the posts *s*² and *s*⁶ acting as guideways and constituting an integral part of the frame-work of the statically-constructed car. The berth-shell *k* is made of thin ductile metallic plate, being raised, paneled, or furrowed to give an ornamental configuration, and at the same time increased strength.

Sliding pins *z*, preferably held in place by springs, are adapted to fix and secure rigidly the berth-shells at any desired height, said pins being preferably connected by any well-known form of mechanism for operating them simultaneously, such devices being well known in the art. Each corner of the berths is provided with a rubber or equivalent elastic medium *g*, for acting as a guide in the slide-ways or angle-posts *s*² and *s*⁶, and at the same time preventing undue concussion, the berths being allowed to hang suspended freely by the wire rope *y* and secured by catches *z*.

The lower berths or seats are braced and counterbraced, as clearly shown in Figs. 30, 31, and 32, and all of said parts are integrally connected to the statically-constructed exterior and interior frame-work of the car, so as to form an integral part thereof.

C represents the floor of the entire car, which in Fig. 1 is shown as having increased central depth, so that the lower portion of the

truss F¹, supporting said floor, lies in close proximity to the road-bed. The lower berths are attached to the lower trusses F¹ in the usual manner, and are of ordinary construction so far as relates to their adaptation to the function of berths or seats. Each single seat may be a whole in itself, instead, as shown in Fig. 26, back to back, and its back may be reversible or adjustable, and at the same time form a statically-constructed frame-work. This frame-work may be made wholly or partly out of thin ductile plate, as specified above for the berth-shells.

U is a stairway leading to the overhead passage V, which passage V is integrally connected to the vertical upright guideways or posts *s*⁶, said passage-way acting, therefore, as an additional horizontal girder with a latticed or plate web. The latter may be perforated or paneled, as desired, which serves the function not only of a passage-way, but also of a strengthening-girder. The roof-truss is not substantially different from that disclosed in my prior applications and patent above referred to, as is also the general internal structure of the car-frame.

By the arrangement shown in Fig. 1, where in the floor proper of the car is located in close proximity to the road-bed, I am enabled to devise a car which shall have a capacity for at least three or more tiers of berths, the upper berths of which are above the passage-way V, or in close proximity thereto, and may be fixed, if preferred, the seating capacity of the lower car being sufficient to seat all the passengers who might utilize the entire set of berths which I have disclosed; or, if need be, the lower set of compartments could be utilized wholly for seating purposes, while the upper portion above and in close proximity to the passage-way could be used for sleeping purposes.

In Fig. 2 I have shown two sets of berths Y²² and Y²³ as being hinged in the ordinary manner; but its fixed frame-work can be also statically constructed according to my inventions. While this type of berth might be utilized, I prefer the horizontally-supported form shown in Figs. 11 and 12, the arrangements being such that the berths can be elevated entirely out of the way from the heads of the passengers beneath.

It will of course be understood that any preferred form of mechanism for raising and lowering the berths may be utilized, such matters being wholly within the skill of those versed in the art.

To still further increase the strength of my improved car-frame, I use corner or knee braces and brackets *o* in various permissible directions without interfering with the use of the car, as clearly shown in Figs. 1, 2, 3, and 12; or they may form part of the girder-work. (See Figs. 5 and 6.)

It will also be understood that the compartment-walls may be of the open-lattice construction, as shown in the various figures,

so as give the interior of the car the appearance of a single compartment; but instead, they, or any of the walls, floor, and ceiling, may be of thin metallic plates worked into any paneled designs, as fully explained above for the berth-shells, and as shown in Figs. 22 and 23.

I do not limit myself to the specific arrangements of parts herein disclosed, as I believe myself to be the first to devise a statically-constructed single or double deck car in which several tiers of sleeping-berths are arranged, with an overhead passage-way, affording access thereto. I believe myself also to be the first to devise a sleeping-car divided into compartments in which the frame-work of the compartments, together with the supporting frame-work of the said berths, are all integrally united to the frame-work of a statically-constructed car, the arrangement being such that a maximum strength and minimum lightness are attained.

I am aware that it is old to construct sleeping-cars in which the upper tier of berths fold up into the side and top of the car; but I am not aware that any one has heretofore devised a sleeping-car in which the berths are arranged in tiers, two or more above each other, the supporting frame-work of which is integrally connected to the statically-constructed portion of the frame-work of the car proper, so that the whole structure is statically braced in all directions, said supporting frame-work thereby serving two functions.

Having thus described my invention, what I claim, and desire to secure by Letters Patent of the United States, is—

1. A railway-car frame statically constructed, having one or more sections each containing two or more sleeping-berths, one above the other, whose fixed frame-work is statically constructed to strengthen and stiffen the car-frame in various directions and integrally connected therewith, in combination with statically-trussed interior horizontal girders rigidly connected to the interior frame-work and forming an overhead passage-way V, substantially as described.

2. A railway-car frame statically constructed, having one or more sections each containing two or more sleeping-berths, one above the other, and having each a fixed frame-work forming girders in a longitudinal as well as transverse direction, all integrally connected together and to the car-frame, substantially as described.

3. A railway-car frame having one or more sections each containing two or more sleeping-berths, one above the other, having hinged folding beds working in a statically-constructed frame or girder work in a longitudinal as well as a transverse direction, this girder-work being integrally connected together and to the car-frame, substantially as described.

4. A railway-car frame forming a statically-constructed body externally and internally, in

combination with an overhead passage-way V to permit access to the upper row or rows of berths, said passage-way forming a statically-constructed interior girder to strengthen and stiffen the interior bracing, and also the whole car-body, substantially as described.

5. A railway car-frame externally statically constructed, in combination with an internal statically-constructed berth frame-work, consisting of one or more series of longitudinal interior girders or struts, each series consisting of two or more girders one above the other, and one or more transverse girders, and one or more horizontal longitudinal girders, all integrally connected together and to the exterior frame-work, substantially as described.

6. A sleeping-car berth having suitable mechanism for raising it and lowering it, and additional means for securing it at various altitudes, in combination with statically-constructed frame-work secured to the car-body and having guide-posts s^2 and s^6 , forming guideways for the berth, substantially as described.

7. A sleeping-berth for a railway-car having a frame or shell constructed of thin ductile metallic plates, having its bottom raised, furrowed, and paneled to give it increased strength with decreased weight, in combination with vertical guideways for the berth, substantially as described.

8. A railway-car frame having one or more sleeping-berths whose bedding shelves and frames are held in position by vertical guide-posts, in combination with wire ropes y , connected to drums and pulleys p , and suitable mechanism for elevating and lowering the same, substantially as described.

9. A railway-car having one or more seat-frames statically constructed and integrally connected thereto, each seat-frame consisting of paneled, furrowed and ductile metallic plates, in combination with horizontal and transverse bracing and trussing, substantially as described.

10. A statically-constructed car-frame divided into sections by transverse girders or frames substantially equal to the length of sleeping-berths, in combination with sleeping-berths adapted to assume various vertical positions in said compartments, and statically-constructed seat-frames integrally connected to the floor and the sides of the car, substantially as described.

11. A railway-car having a series of berths and seats located in fixed compartments on either side of a central aisle, in combination with an overhead passage-way, the whole forming a statically-constructed external and internal frame-work integrally connected together, and having a stairway connecting the lower frame with the overhead passage-way, substantially as described.

12. A railway-car having a series of seats arranged in separate compartments on the floor of the car about either side of an aisle, in combination with a series of berths located

in compartments above said seats, an overhead passage-way connected by a stairway to the lower floor of the car, the whole forming a statically-constructed frame-work, substantially as described.

13. In a railway-car, a series of seats located back to back on the floor of the car on opposite sides of a central aisle in separate compartments, in combination with a series of berths arranged in one or more tiers above said seats, and an overhead passage-way connected by a stairway to the lower floor, the whole forming a statically-constructed frame-work and being arranged substantially as described.

14. In a railway-car, a series of seats located on opposite sides of a central aisle on the floor of the car, in combination with a series of berths arranged in tiers above said seats, and an overhead passage-way connected by a stairway to the lower floor, said berths and seats being held in position in a series of compartments having vertical posts attached to the bottom, top, and side walls of a statically trussed car-frame, substantially as described.

15. A railway-car frame externally and internally statically constructed, containing sleeping-berths, where any or all spaces not necessary for the easy access and exit and for operating same are trussed and kneebraced in any one or various directions to increase the strength and rigidity of the car-body, substantially as described.

16. A railway-car frame externally statically constructed, in combination with an internal statically - constructed berth frame-work consisting of one or more series of ver-

tical and horizontal longitudinal interior girders or struts, each series consisting of two or more similarly-placed girders one above the other, and one or more transverse girders, all integrally connected together and to the exterior frame-work, substantially as described.

17. A railway-car frame externally statically constructed, in combination with an internal statically - constructed berth frame-work consisting of one or more series of horizontal, vertical, and inclined interior longitudinal girders or struts, each series consisting of two or more similarly-placed girders one above the other, and one or more transverse girders, all integrally connected together and to the exterior frame-work, substantially as described.

18. A railway-car having one or more statically-constructed seat-frames, each having its sides worked into the requisite shape out of thin ductile metallic plates, in combination with trussing or bracing at the back of the seat, and additional bracing or trussing under the seat-cushion adapted to support the latter, substantially as described.

19. A railway-car having one or more statically-constructed seat-frames, each having one or more stands or sides which are formed with trussing and bracing, said trussing and bracing being embodied in the back and bottom of the seat, whereby additional strength is given to the seat, substantially as described.

MAX A. ZÜRCHER.

Witnesses:

AUGUST GÉRIN,
WENDELL A. ANDERSON.