

(19) World Intellectual Property Organization
International Bureau



(43) International Publication Date
13 March 2008 (13.03.2008)

PCT

(10) International Publication Number
WO 2008/030094 A2

(51) International Patent Classification:
H05K 7/20 (2006.01) *F28D 19/04* (2006.01)

(74) Agent: HATZMANN, M., J.; Vereenigde, Johan de Witt-
laan 7, NL-2517 JR Den Haag (NL).

(21) International Application Number:
PCT/NL2007/050435

(81) Designated States (*unless otherwise indicated, for every kind of national protection available*): AE, AG, AL, AM, AT, AU, AZ, BA, BB, BG, BH, BR, BW, BY, BZ, CA, CH, CN, CO, CR, CU, CZ, DE, DK, DM, DO, DZ, EC, EE, EG, ES, FI, GB, GD, GE, GH, GM, GT, HN, HR, HU, ID, IL, IN, IS, JP, KE, KG, KM, KN, KP, KR, KZ, LA, LC, LK, LR, LS, LT, LU, LY, MA, MD, ME, MG, MK, MN, MW, MX, MY, MZ, NA, NG, NI, NO, NZ, OM, PG, PH, PL, PT, RO, RS, RU, SC, SD, SE, SG, SK, SL, SM, SV, SY, TJ, TM, TN, TR, TT, TZ, UA, UG, US, UZ, VC, VN, ZA, ZM, ZW.

(22) International Filing Date:
6 September 2007 (06.09.2007)

(25) Filing Language: Dutch

(26) Publication Language: English

(30) Priority Data:
1032450 6 September 2006 (06.09.2006) NL

(71) Applicants (*for all designated States except US*): UP-
TIME TECHNOLOGY BV [NL/NL]; Tuinlaan 90,
NL-3111 AW Schiedam (NL). LODDER, Robbert, Mees
[NL/NL]; Koningin Emmalaan 19, NL-2635 HH Den
Hoorn (NL). SCHAAP, Wolter [NL/NL]; Rijkssstraatweg,
NL-3783 AX Voorst (NL).

(84) Designated States (*unless otherwise indicated, for every kind of regional protection available*): ARIPO (BW, GH, GM, KE, LS, MW, MZ, NA, SD, SL, SZ, TZ, UG, ZM, ZW), Eurasian (AM, AZ, BY, KG, KZ, MD, RU, TJ, TM), European (AT, BE, BG, CH, CY, CZ, DE, DK, EE, ES, FI, FR, GB, GR, HU, IE, IS, IT, LT, LU, LV, MC, MT, NL, PL, PT, RO, SE, SI, SK, TR), OAPI (BF, BJ, CF, CG, CI, CM, GA, GN, GQ, GW, ML, MR, NE, SN, TD, TG).

(72) Inventors; and

(75) Inventors/Applicants (*for US only*): MATSER, Pe-
dro [NL/NL]; Zandkamp 205, NL-3828 GN Hoogland
(NL). VAN DIJK, Marcel [NL/NL]; Hoogwerfsingel 23,
NL-3202 SM Spijkensisse (NL).

Published:

— *without international search report and to be republished upon receipt of that report*

(54) Title: APPARATUS AND METHOD FOR COOLING A SPACE IN A DATA CENTER BY MEANS OF RECIRCULATION AIR

(57) Abstract: An apparatus for cooling an air humidity- and temperature-conditioned space in a data center in which ICT and/or telecom equipment is arranged. The space is cooled using air flow that recirculates in the space. The apparatus is characterized in that the air stream heated by the equipment is supplied as a first air stream to an air-to-air heat exchanger, in which the first air stream is cooled by means of a separate second air stream.



WO 2008/030094 A2

P78344PC00

Title: Apparatus and method for cooling a space in a data center by means of recirculation air

The invention relates to an apparatus and method for cooling a space in a data center using recirculation air, which space is air humidity- and temperature-conditioned and in which ICT and/or telecom equipment is arranged.

5 Data centers are generally known and usually comprise at least one space in which ICT and/or telecom equipment is arranged, such as computer, server or network equipment. For a proper operation of the equipment, a proper and stable temperature and air humidity in the space are important. A proper operating temperature for the equipment is
10 between about 20°C and about 25°C and a proper air humidity is between about 45% and about 55%. In view of the heat production of the ICT and/or telecom equipment, it is desirable to cool the space in order to keep the space at a stable temperature and air humidity. A data center is usually in
15 operation 24 hours a day, seven days a week, and so the ICT and/or telecom equipment should be cooled practically continuously. The conditioned spaces in data centers are accessible to persons, and for that purpose are ventilated.

To cool the space, it is usually provided with a raised floor under which a cold air stream is blown. Via apertures in the floor, the air stream is
20 blown into the space. At the top of the space, the heated air stream is extracted and, after cooling, the cooled air stream is again blown under the raised floor. Thus, the air stream is recirculated in the space.

The air stream is cooled by means of a cooling unit, usually a compression cooling unit in which a refrigerant is compressed. The heated
25 air stream gives off its heat to the refrigerant or to a cooling liquid functioning as intermediate medium. Usually, water is utilized as intermediate medium to carry the released heat out of the space.

The ICT and/or telecom equipment is usually placed in a system cabinet. Known system cabinets can be cooled in a vertical manner or in a horizontal manner. With cooling in a vertical manner, cold air flow is blown into the system cabinet at the bottom thereof and then, by fans, transported upwards, along the way cooling the equipment. A disadvantage is that the cold air stream heats up gradually, so that the air stream in the upper region of the system cabinet is warmer than the air stream in the lower region of the system cabinet. Due to this gradual heat-up of the air stream in the system cabinet for cooling the equipment, only a limited amount of equipment can be placed in the system cabinet, so that not the whole system cabinet can be utilized.

With cooling in a horizontal manner, the cooled air stream is passed horizontally through the equipment arranged in the system cabinet, by means of fans of the ICT and/or telecom equipment. The heated air stream leaves the system cabinet at the back. A disadvantage is that the heated air stream of one system cabinet can mix with the cooled air stream of another system cabinet. Another disadvantage of vertical cooling is that cooled air flow can mix with heated air, without cooling any equipment.

Cooling through recirculation air an air humidity- and temperature-conditioned space in a data center in which ICT and/or telecom equipment is arranged, is not done efficiently in the known manner. Usually, the air stream is cooled to a temperature that is considerably lower than the operating temperature. Furthermore, use is made of relatively complex cooling units, and cooling involves much loss. As a consequence, much energy is required and the electricity costs of a data center are high. Especially in the case of a large data center, the costs of energy consumption consequently account for a considerable part of the total operational costs of the data center. Since the refrigerant is typically a propellant, in case of leakage of the refrigerant from the cooling unit, propellant may end up in the atmosphere, causing an environmental impact. Moreover, as a

consequence of the use of water to dissipate the released heat from the space, water conduits are present in the space. These might start to leak and then constitute a danger to the ICT and/or telecom equipment arranged in the space.

5 The object of the invention is to provide an apparatus of the type mentioned in the opening paragraph hereof which, while maintaining the above-mentioned advantages, can obviate the above-mentioned disadvantages.

10 To that end, the invention provides an apparatus for cooling by means of recirculation air an air humidity- and temperature-conditioned space in a data center in which ICT and/or telecom equipment is arranged, wherein the apparatus comprises an air-to-air heat exchanger, wherein recirculation air heated by the equipment is supplied as a first air stream to the air-to-air heat exchanger, and wherein the first air stream is cooled
15 using a separate second air stream.

 By providing an air-to-air heat exchanger, no use needs to be made anymore of a complex cooling unit with refrigerant and any intermediate medium, so that cooling is done more efficiently. This can yield a considerable saving of energy and hence of costs. Also, the environmental
20 impact is reduced, because less energy is needed.

 Since no refrigerant is needed anymore, the environmental impact – resulting from leaking propellant – is also reduced.

 Preferably, the air-to-air heat exchanger is designed as a heat wheel. An advantage of the heat wheel as a heat exchange body is the
25 efficient manner of heat transfer from the first air stream to the second air stream. Moreover, moisture transport between the first and the second air stream can be minimal, so that the air humidity of the first air stream remains approximately equal. For the practically continuous cooling of the recirculation air in the space in the data center, a heat wheel can be utilized
30 in a particularly efficient manner. Further, the temperature of the cooled

first air stream can be approximately equal to the operating temperature. In a region with a comparable type of climate to the Netherlands, and when using outside air flow as a second air stream, the heat wheel, at non-stop operation, can be used for nearly 80% of the time. Only for the residual 20%
5 may the outside air stream be too warm and may limited additional cooling be needed supplemental to the cooling with the heat wheel. It is noted that within this context a heat wheel is understood to mean an air-to-air heat exchanger provided with a rotatably arranged, plate-shaped heat exchange body. The heat exchange body is preferably substantially of metal. The heat
10 exchange body then extends preferably through a partition between two air chambers through which the first and second air stream, respectively, are guided. The heat exchange body is preferably disc-shaped and may optionally be provided with perforations. Elegantly, the heat exchange body is disposed horizontally. What can thus be achieved is that the dimensions
15 of the heat exchange body require no greater construction height than the height of a conventional storey.

With the heat wheel, for a data center a sufficiently large cooling capacity can be realized, while leakage, if any, between the first and the second air stream does not entail any problems for such an application.

20 A large cooling capacity can for instance be achieved by making the heat wheel of large design or by using a plurality of smaller heat wheels. The rotary speed of a large heat wheel can be kept low for a considerable part of the time while yet sufficient cooling capacity can be achieved and leakage can be limited.

25 Preferably, the first air stream cooled by the air-to-air heat exchanger is supplied to the equipment separately from the air stream heated by the equipment. This prevents the heated first air stream from mixing with the cooling air, so that the temperature of the air stream cooled by the air-to-air heat exchanger can be approximately equal to the desired

operating temperature. This yields a further saving of energy and hence of costs.

In another advantageous embodiment, the second air stream is supplied from outside the conditioned space. This can for instance be air from another space in the data center, or outside air. By making use, for instance, of outside air, the recirculation air can be cooled in an advantageous manner.

The invention further relates to a method for cooling by means of recirculation air an air humidity- and temperature-conditioned space in a data center in which ICT and/or telecom equipment is arranged, and to the use of a heat wheel, for cooling a recirculation air of an air humidity- and temperature-conditioned space of a data center in which ICT and/or telecom equipment is arranged. Further advantageous embodiments of the invention are represented in the subclaims. The invention will be elucidated with reference to an exemplary embodiment represented in a drawing. In the drawing:

Fig. 1 shows a schematic view of a space with equipment;

Fig. 2 shows a schematic view of an air-to-air heat exchanger.

It is noted that the figures are only schematic representations of a preferred embodiment of the invention that is described by way of non-limiting exemplary embodiment. In the figures, like or corresponding parts are designated with the same reference numerals.

In Fig. 1 a conditioned space 1 in a data center is shown. In the space 1, a stable temperature and air humidity prevail. Preferably, the air humidity is between 45% and 55%. In the space 1, ICT and/or telecom equipment 2 is arranged. The equipment 2 produces heat and is therefore cooled using an air stream that recirculates in the space 1. Preferably, the operating temperature of the equipment is between 20°C and 25°C. For the purpose of the air recirculation and the cooling, the space 1 is provided with a raised floor 3.

The equipment 2 comprises for instance computer, network or server equipment and is preferably arranged in a system cabinet 14. In this exemplary embodiment, system cabinets 14 are provided with a front 4 to which a cooled first air stream is supplied and a back 5 along which a heated first air stream is removed. The equipment 2 has a front 16 facing the front 4 of the system cabinet 14, and a back 17 facing the back 5 of the system cabinet 14.

To prevent heated air flow from mixing with the cooled first air stream, the system cabinets 14 have their fronts 4 facing each other, to thereby form a 'cold corridor' 6. In this exemplary embodiment, the cold corridor 6 is closed off with sidewalls and a ceiling 7, to thereby create a closed space within the space 1, and to separate the heated first air completely from the cooled first air stream. The heated first air is cooled by means of a cooling device 8, and the cooled first air stream is thereupon blown under the raised floor 3.

The recirculation of the first air stream in the space 1 proceeds as follows. A cooled first air stream 9 is blown under the raised floor 3. Adjacent the fronts 4 of the system cabinets 14, there are apertures in the floor through which the cooled first air stream 9 is blown. The cooled first air stream 9 is supplied to the fronts 4 of the system cabinets 14 and in them is drawn to the back 5 by the fans of the equipment 2 arranged in the system cabinets 14. On the way, the equipment 2 is cooled, as a result of which the cooled first air stream heats up, and the first air stream exits at the back 5 from the system cabinets 14 as a heated first air stream 10. Upon passing through the system cabinet 14, the cooled first air stream 9 will have heated up by some 6 to 12°C, on average, thereby rendered a heated first air stream 10. The heated first air stream 10 is outside the cold corridor 6 and cannot mix with the cooled first air stream 9 because of the ceiling 7. As a consequence, no losses occur and the cooled first air stream 9 can be presented to the equipment 2 at the operating temperature of the

equipment 2, between 20°C and 25°C. The cooled first air stream 9 exiting from an exit opening 19 of the cooling device 8 is thus supplied separately via a supply duct 15 to the front 16 of the equipment 2. The heated first air stream 10 is removed from the space 1 near the ceiling via a discharge duct, not shown, and is supplied to an inlet opening 18 of the cooling device. The first air stream thus recirculates in the space 1, while in this exemplary embodiment the cooled first air stream 9 is separated from the heated first air stream 10.

The cooling device 8 is designed as an air-to-air heat exchanger 8 to which the heated first air stream 10 is supplied. In the air-to-air heat exchanger 8, the heated first air stream 10 is cooled using a separate second air stream 12. Preferably, as shown in Fig. 1, the second air stream 12 is supplied from outside the space 1. In an advantageous embodiment, the second air stream 12 is outside air. In the air-to-air heat exchanger 8, the first air stream 10 and the second air stream 12 remain separate from each other, and therefore no mixing or substantially no mixing of first and second air stream takes place.

Fig. 2 shows a schematic view of an air-to-air heat exchanger 8. The air-to-air heat exchanger 8 is provided with a plate-shaped heat exchange body 13, for instance a substantially metallic plate with small apertures through which air can move. The plate can have any shape, but is preferably rectangular or circular. The heat exchange body 13 may also be designed as a plate-shaped disc wound from corrugated metal plate. The heat exchange body 13 is rotatably arranged and moves successively through the heated first air stream 10 and the cooler second air stream 12. The heat exchange body 13 extends through a partition between two air chambers through which the first air stream 10, 11, and the second air stream 12, respectively, are guided. Optionally, brushes may be provided, which prevent air being passed through the partition along with the heat wheel, so that leakage can be limited. If desired, optionally, a mixing

chamber may be provided in the partition between the air chambers, to prevent unwanted exchange between the air streams, such as for instance moisture entry or moisture loss.

When the heat exchange body 13 moves through the heated first air stream 10, the heat exchange body 13 is heated up and the heated first air stream 10 cools down to a cooled first air stream. Next, the heated heat exchange body 13 moves through the cool incoming second air stream 12, as a result of which the second air stream 12 is heated up to a warm exiting second air stream and the heat exchange body 13 cools down.

In an advantageous embodiment, the air-to-air heat exchanger 8 is designed as a heat wheel, as shown in Fig. 2. In a heat wheel, the heat exchange body 13 is designed as a circular thin metal wheel with small apertures through which air can move. An advantage of the heat wheel is that moisture transfer between the first and second air stream can be minimal, so that the air humidity of the first air stream 9, and hence the air humidity in the space 1, remains substantially unchanged. The construction of the heat wheel will not be discussed in more detail here, since it is well known to those skilled in the art. An example of the construction of a heat wheel is described in the publication 'Hoval Rotary Heat Exchanger for Heat Recovery in Ventilation Systems' HW 60aE1 11/2002 as available on www.hoval.com of Hovalwerk AG, in particular on page 8 of the publication.

If the second air stream 12 is a stream of outside air, it can for instance be used up to an inlet temperature of 18°C for complete cooling of the heated first air stream to 22°C. Since the equipment in the space in the data center needs to be cooled substantially continuously, and since the outside air temperature including nights in countries of a climate type like the Netherlands is lower than 18°C for an average 80% of the time, the heat wheel can be deployed for cooling the data center for as much as 80% of the time without additional cooling. For the residual 20% of the time, the

temperature of the outside air stream will often be such that additional cooling is needed. Additional cooling can be realized with any other type of cooling device. In an environmentally friendly manner, additional cooling can for instance be carried out by means of soil storage, whereby air is
5 drawn from a cool underground buffer space.

Since a cooling device 8 for cooling the first air stream in a conditioned space 1 in a data center is needed virtually continuously – 24 hours a day, seven days a week – the use of an air-to-air heat exchanger, and in particular of a heat wheel, is extremely efficient, as no refrigerant
10 and cooling liquid are used. Thus, a considerable saving on energy consumption and hence on electricity costs can be achieved. Also, there is less environmental impact owing to the absence of an environmentally unsound refrigerant and owing to the lower energy consumption.

As long as a cooling demand is substantially unchanged – for instance in that the same amount of equipment 2 in the space remains
15 active – and the temperature of the second air stream 12 is practically unchanged, a flow rate of the first air stream 9 and the second air stream 12 will likewise remain substantially unchanged, since the cooling demand depends on the amount of heat being produced by the equipment 2. Upon a
20 change of the cooling demand, for instance in that more or less equipment 2 in the space 1 is active, the flow rate of the first air stream 9, 10 can be changed. If the temperature of the incoming second air stream 12 changes, for instance due to the surroundings becoming hotter or colder, also the flow rate of the second air stream 12 can be adjusted. As the flow rate of the
25 second air stream 12 can be adjusted, it can be ensured that the temperature of the cooled first air stream 9 remains substantially unchanged. So, the flow rate of the second air stream 12 depends on the difference in temperature between the second air stream 12 and the first air stream 10. The flow rate can then be controlled depending on the desired
30 temperature of the cooled first air stream, for instance 22°C. The flow rate

can for instance be controlled by adjusting the rotary speed of the heat wheel. In a type of climate as in the Netherlands, the rotary speed can be low for a large part of the time.

5 The heat wheel, when arranged horizontally, may optionally be supported to prevent bending, for instance using support rollers.

It will be clear that the invention is not limited to the exemplary embodiments represented here. For instance, the cooling device may be disposed inside the space or outside it, or – as shown in Fig. 1 – partly inside the space and partly outside. Also, the cooling device may be disposed
10 outside the data center. If the cooling device is disposed outside the space, the heated first air stream will for instance be carried to the air-to-air heat exchanger via a ceiling of the space. The additional cooling can be done in various ways, for instance by adiabatic cooling or by means of a conventional liquid cooling. Such variants will be clear to those skilled in
15 the art and are understood to be within the scope of the invention as set forth in the appended claims.

CLAIMS

1. An apparatus for cooling by means of recirculation air an air humidity- and temperature-conditioned space in a data center in which ICT and/or telecom equipment is arranged, characterized in that the apparatus comprises an air-to-air heat exchanger, wherein recirculation air heated by
5 the equipment is supplied as a first air stream to the air-to-air heat exchanger, and wherein the first air stream is cooled using a separate second air stream.
2. An apparatus according to claim 1, wherein the first air stream cooled by the air-to-air heat exchanger is supplied to the equipment
10 separately from the first air stream heated by the equipment.
3. An apparatus according to claim 1 or 2, wherein the second air stream is supplied from outside the conditioned space.
4. An apparatus according to any one of the preceding claims, wherein the second air stream is outside air.
- 15 5. An apparatus according to any one of the preceding claims, wherein the air-to-air heat exchanger is arranged outside the space.
6. An apparatus according to any one of the preceding claims, wherein the air-to-air heat exchanger is arranged outside the data center.
7. An apparatus according to any one of the preceding claims,
20 wherein the air-to-air heat exchanger comprises a plate-shaped heat exchange body which moves successively through the first air stream and the second air stream.
8. An apparatus according to claim 8, wherein the heat exchange body extends through a partition between two chambers, through which
25 chambers the first and the second air stream, respectively, are guided.

9. An apparatus according to any one of the preceding claims, wherein the cooled first air stream is introduced into the space via a floor, and the heated first air stream is removed from the space via a ceiling.

10. An apparatus according to any one of the preceding claims,
5 wherein the cooled first air stream is supplied at a front of the equipment, and the heated first air stream is removed at a back of the equipment.

11. An apparatus according to any one of the preceding claims, wherein the cooled first air stream is supplied from an exit opening via a supply duct, separately from the heated first air stream, to the front of the
10 equipment.

12. An apparatus according to any one of the preceding claims, wherein the cooling apparatus is provided with an exit opening and a supply duct connected thereto which supplies the cooled first air stream, preferably as a separate air stream, to the equipment to be cooled.

15 13. An apparatus according to any one of the preceding claims, wherein the cooling apparatus is provided with an inlet opening and a discharge duct connected thereto which discharges the heated first air stream from the space to be cooled.

14. An apparatus according to any one of the preceding claims,
20 wherein the equipment is arranged in the space in the data center with the fronts facing each other.

15. An apparatus according to claim 14, wherein the fronts of the equipment are situated in a substantially closed space in the data center to which the cooled first air stream is supplied.

25 16. An apparatus according to claim 15, wherein the heated first air stream is discharged outside the closed space, at the backs of the equipment.

17. An apparatus according to any one of the preceding claims, wherein a flow rate of the first air stream is adjustable.

18. An apparatus according to any one of the preceding claims, wherein the temperature of the cooled first air stream is greater than or equal to 20°C.
19. An apparatus according to any one of the preceding claims,
5 wherein the apparatus comprises an additional cooling for supplementing the cooling by means of the air-to-air heat exchanger.
20. An apparatus according to claim 19, wherein the additional cooling comprises a soil storage.
21. An apparatus according to claim 19, wherein the additional cooling
10 comprises a cooling in an adiabatic manner.
22. A data center, comprising an air humidity- and temperature-conditioned space where ICT and/or telecom equipment is arranged, and an apparatus which cools the space using recirculation air, the apparatus being designed according to at least one of the preceding claims.
- 15 23. A method for cooling by means of recirculation air an air humidity- and temperature-conditioned space in a data center in which ICT and/or telecom equipment is arranged, wherein an air stream heated by the equipment is supplied as a first air stream to an air-to-air heat exchanger, wherein the first air stream is cooled using a separate second air stream.
- 20 24. A method for cooling a conditioned space in a data center according to claim 23, wherein, depending on a cooling demand of the equipment, the flow rate of the recirculation air is adjusted.
- 25 25. A method for cooling a conditioned space in a data center according to any one of claims 22-24, wherein, depending on the temperature difference between the heated first air stream and the second air stream, a flow rate of the second air stream is adjusted.
26. Use of an air-to-air heat exchanger, in particular a heat wheel, for cooling recirculation air of an air humidity- and temperature-conditioned space of a data center in which ICT and/or telecom equipment is arranged.

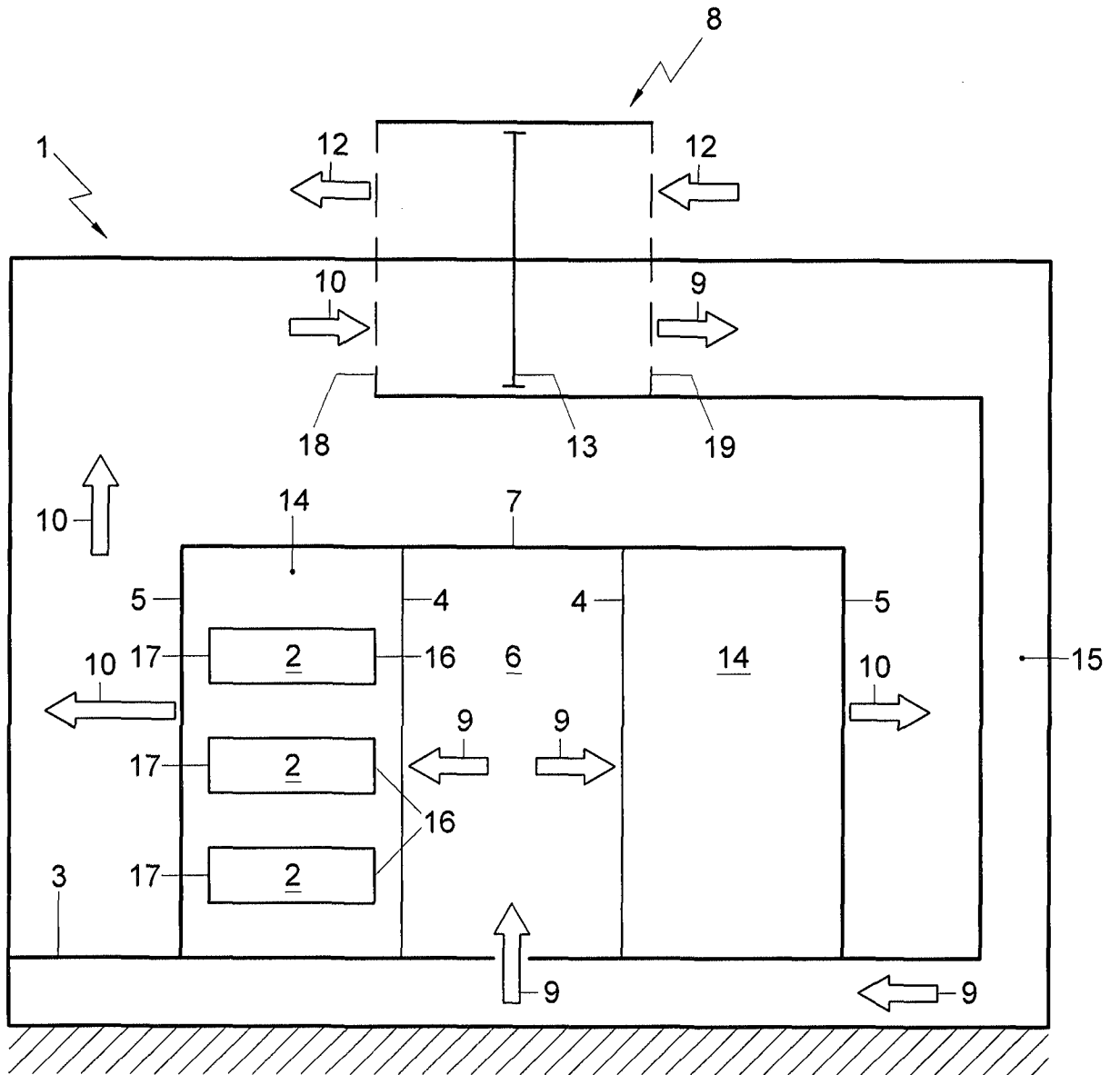

Fig. 1

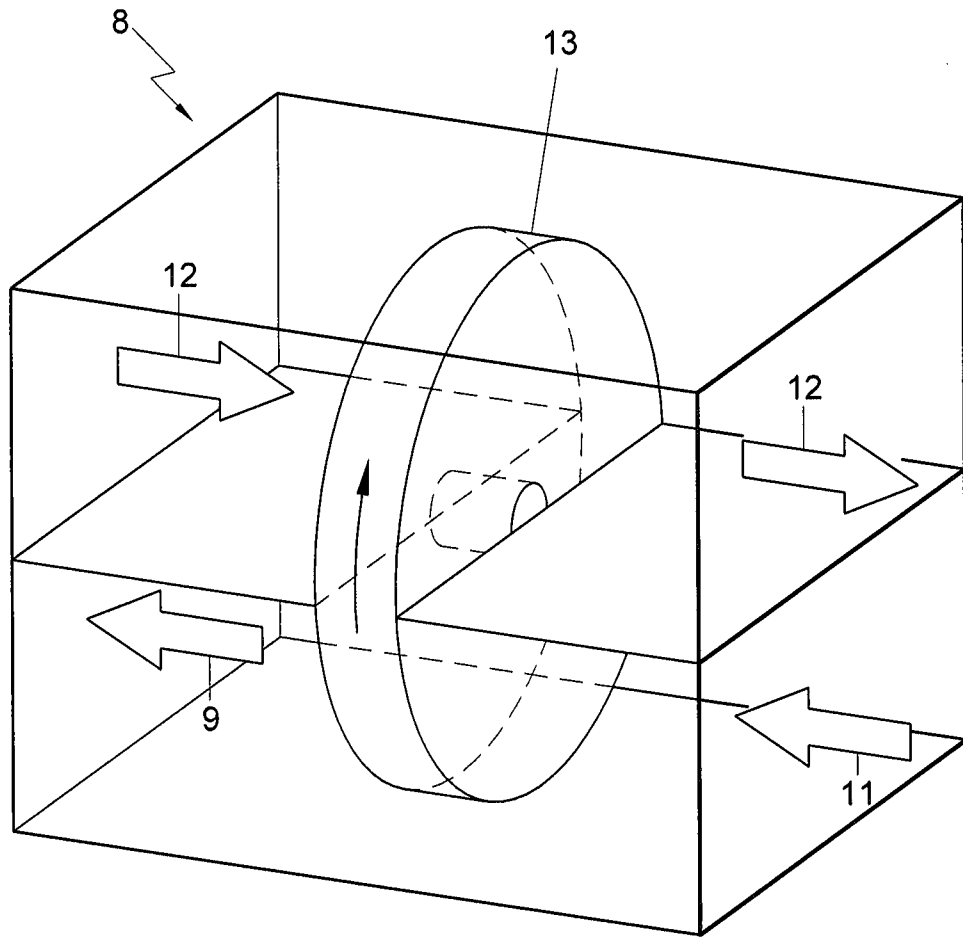

Fig. 2