

(19) **DANMARK**

(10) **DK/EP 2880746 T3**



(12) **Oversættelse af
europæisk patentskrift**

Patent- og
Varemærkestyrelsen

-
- (51) Int.Cl.: **H 02 K 5/18 (2006.01)** **H 02 K 5/20 (2006.01)** **H 02 K 9/06 (2006.01)**
H 02 K 11/33 (2016.01) **H 02 K 9/14 (2006.01)**
- (45) Oversættelsen bekendtgjort den: **2020-01-27**
- (80) Dato for Den Europæiske Patentmyndigheds bekendtgørelse om meddelelse af patentet: **2019-11-27**
- (86) Europæisk ansøgning nr.: **13739970.5**
- (86) Europæisk indleveringsdag: **2013-07-17**
- (87) Den europæiske ansøgnings publiceringsdag: **2015-06-10**
- (86) International ansøgning nr.: **EP2013065098**
- (87) Internationalt publikationsnr.: **WO2014019854**
- (30) Prioritet: **2012-08-02 DE 102012107107**
- (84) Designerede stater: **AL AT BE BG CH CY CZ DE DK EE ES FI FR GB GR HR HU IE IS IT LI LT LU LV MC MK MT NL NO PL PT RO RS SE SI SK SM TR**
- (73) Patenthaver: **EBM-Papst Mulfingen GmbH&CO. KG, Bachmühle 2, 74673 Mulfingen, Tyskland**
- (72) Opfinder: **Haag, Christian, Eberbacher Str. 6, 74673 Mulfingen, Tyskland**
WALTER, Sven, Goldbachstr. 38, 97980 Bad Mergentheim-Rengershausen, Tyskland
SUDLER, Björn, Hans-Weiher-Weg 8a, 97944 Boxberg-Schwabhausen, Tyskland
HAAF, Oliver, Georg-Adam-Reinhard-Str. 12, 74635 Kupferzell, Tyskland
- (74) Fuldmægtig i Danmark: **Chas. Hude A/S, H.C. Andersens Boulevard 33, 1780 København V, Danmark**
- (54) Benævnelse: **AKTIV AFKØLING AF EN MOTOR**
- (56) Fremdragne publikationer:
EP-A2- 2 405 561
DE-A1- 10 313 273
US-A- 2 778 958
US-A- 4 908 538
US-A1- 2011 074 235

Description

The invention relates to a motor comprising an electronics housing, a stator having a stator bushing, and a rotor, wherein the motor having the stator bushing can be mounted on a mounting wall.

Such motors are used, in particular, for driving fans and have integrated electronics, in particular commutation electronics. The maximum power range of the motors is generally limited by the maximum component temperatures of the electronics, for example of the electric power components, such as power amplifiers, or of the motor, for example of the motor winding or of the ball bearings. The service life of the motor is likewise dependent on the component temperatures that are reached during operation of the motor, with elevated temperatures shortening the service life of the motor.

The motors are mounted, in particular, on a stable mounting wall, which is part of an installation housing, for example, in which the fan is installed. In this case, the electronics housing is typically inserted into a mounting opening in the mounting wall, and the motor is mounted on the mounting wall by means of the stator bushing. A mounting of this type makes effective cooling of the motor and of the electronics more difficult because a flow around the motor and around the electronics housing in the axial direction of the motor is impeded by the mounting wall. Moreover, particularly in the case of radial fans, flow around the motor is poor or does not occur at all, due to the radial outflow of the air. In the case of axial fans, what is known as a wake area is formed in the region of the rotor bell, and this likewise has a negative impact on flow around the motor.

Similar motors are known, for example, from DE 103 13 273 A1, US 2 778 958 A, US 4 908 538 A, EP 2 405 561 A2, and US 2011/074235 A1.

The aim of the invention is to create a motor, the cooling of which is improved and the power and service life of which are increased at the same ambient temperature.

The aim is achieved by a motor according to claim 1.

Such a motor enables active and targeted cooling of temperature-critical components of the motor, in particular of the motor electronics and of the ball bearing of the stator, by means of an air volume flow generated by the air conveying element. The air volume flow is guided in targeted manner by means of the air guide element and the flow gap of the flow space to the components of the motor that are particularly to be cooled, in particular to the stator bushing and to the region of the electronics housing, and intensifies cooling as compared with passive cooling by means of convection brought about by common ambient air. Increased power and a longer service life of the motor are thereby made possible.

In a preferred embodiment of the motor, the air conveying element is configured as a radial fan wheel. The radial fan wheel draws the air volume flow in axially and blows it out radially so that the air volume flow can be generated particularly effectively and so as to flow parallel to the motor axis.

Depending on the embodiment of the motor, cooling the electronics housing may be more important than cooling the stator bushing, or in the case of a specific application or installation situation, the ambient air may have a lower temperature in the region of the electronics housing than in the region of the rotor.

In a first embodiment of the invention, the air guide element can be mounted on the mounting wall and is arranged between the mounting wall and the air conveying element, with the suction opening of the air conveying element being aligned in the direction of the mounting wall. In this case, during motor operation the air conveying element generates a negative pressure in the region of its suction opening and the region of the opposite through-flow opening of the air guide element. An air volume flow is guided by the air guide element through a channel opening arranged in the mounting wall, and through the flow gap into the flow space, and along the outer circumferential surface of the stator bushing, up to the through-flow opening of the air guide element, and is drawn in axially from the direction of the mounting wall by the air conveying element at its suction opening, and blown out radially in the region of the rotor. In this embodiment of the invention, the air volume flow to be cooled is drawn

in first in the region of the electronics housing, and thus the electronics housing is cooled particularly well, and the cooling effect is generally improved.

Alternatively, cooling the stator bushing may be more important than cooling the electronics housing, or in the case of a specific application or installation situation, the ambient air in the region of the rotor may have a lower ambient temperature than in the region of the electronics housing.

In a second embodiment of the motor, the air guide element can be mounted on the mounting wall, and the air conveying element is located within the air guide element, with the suction opening of the air conveying element being aligned facing away from the mounting wall. In this case, during motor operation the air conveying element generates a negative pressure in the region of its suction opening, and draws in the air to be cooled axially through the through-flow opening of the air guide element from the direction opposite the mounting wall in the region of the rotor, and blows it out radially into the flow space. An air volume flow is guided by means of the air guide element through the flow space and along the outer circumferential surface of the stator bushing through the flow gap, and through the channel opening in the mounting wall up to an outer circumference of the electronics housing. In the alternative embodiment of the invention, the cooling air volume flow is drawn in on the rotor side, and thus the stator bushing is cooled first particularly well, and the cooling effect is generally improved.

According to the invention, the motor comprises an air guide channel arranged on the outer circumference of the electronics housing, which channel can be mounted on the mounting wall, with the air guide channel running from a channel opening, disposed in the region of the flow space, in the mounting wall to a region to be cooled on the outer circumference of the electronics housing.

Such a configuration of the motor enables active cooling of the electronics housing even in the case of installation on a mounting wall having a mounting opening, without requiring significant modifications of existing motor types, because no modifications of the electronics housing or of the stator bushing are required. Depending upon the installation situation, it is necessary only for an additional

connection opening in the mounting wall for connecting the air guide channel and the air guide element to be provided, or for an existing opening to be enlarged or adapted, so that the air guide channel and the air guide element can be sufficiently connected to one another.

In a further embodiment of the invention, the air guide channel has an annular circumferential attachment at its end that abuts to the outer circumference of the electronics housing, which attachment is form-fitted in particular to the outer circumferential extension of the electronics housing or of the housing cooling ribs.

The attachment increases the surface area of the electronics housing that is covered by the air guide channel and is thus cooled by the air volume flow.

In a further embodiment of the invention, the air conveying element has a funnel-shaped ring collar on the side of the air guide element at the edge of the suction opening, and the air guide element has a circumferential annular groove on the side of the air conveying element at the edge of the through-flow opening, with the annular collar projecting into the annular groove, and annular collar and annular groove together forming the sealing gap. This allows improved fluidic sealing between the suction opening of the air conveying element and the through-flow opening of the air guide element.

Further details, features, and advantageous further developments of the invention arise from the exemplary embodiments described below and depicted in the drawings. The drawings show the following:

figure 1 shows a three-dimensional exploded drawing of a first embodiment of a motor according to the invention having a support structure,

figure 2 shows a side view of the first embodiment of a motor according to the invention having a support structure, with a partial cross section in the region of the air guide element and the air guide channel;

figure 3 shows a side view of a second embodiment of a motor according to the invention having a support structure, with a partial cross section in the region of the air guide element and the air guide channel.

The same components are provided with the same reference signs in all the figures.

Figure 1, figure 2, and figure 3 each show a motor according to the invention, in particular an external rotor motor. The motor comprises an electronics housing 1, a stator comprising a stator bushing 3 and a stator laminated core 4 having motor windings, and a rotor 5, in particular an external rotor. The stator bushing 3 and the electronics housing 1 are particularly made of metal. Inside the electronics housing 1 are, among other things, the motor electronics for driving and for controlling the motor, in particular the commutation electronics with electrical power components such as power amplifiers. The electronics housing 1 has housing cooling ribs 7 at its outer wall for cooling electronic components (not shown) inside the electronics housing 1. The stator bushing 3 has stator cooling ribs 8 at its outer wall, which ribs extend radially and conduct away the heat that is generated by the stator, in particular by ball bearings and motor windings (not shown) that are installed in the stator.

For mounting, the motor is mounted, in particular by means of the stator bushing 3, on a support structure 10 or on a mounting wall 11 having a mounting opening 30. In one embodiment of the invention, the mounting wall 11 may be part of a support structure 10 configured as a component of the motor so that the support structure 10 forms the mounting wall 11. Alternatively, the mounting wall 11 may result from the installation situation, e.g., as a wall of an installation housing in which the motor is mounted. The motor is mounted in the mounting opening 30 in such a way that the electronics housing 1 is located on one side of the mounting wall 11, and the stator and the rotor 5 of the motor are located on the other side of the mounting wall 11.

According to the invention, the motor has an air guide element 22a, 22b and an air conveying element 14, both of which are annular and surround the stator. The air guide element 22a, 22b has a through-flow opening 26 on the side of the rotor 5.

In the embodiment shown in figure 1 and figure 2, the diameter of the through-flow opening 26 is dimensioned, in particular, such that both the electronics housing 1 and the stator bushing 3 can be inserted through the through-flow opening 26. This enables the air guide element 22a to be installed on the mounting wall 11 independently of the motor. The air guide element 22a, 22b surrounds the stator in particular in a shell-like manner in the region of the stator bushing 3, thereby creating a circumferential flow space 35 between the air guide element 22a, 22b and an outer circumference of the stator bushing 3. The air guide element 22a, 22b and the air conveying element 14 are made in particular of plastic. During operation of the motor, the air conveying element 14 is driven via the motor. The air conveying element 14 is configured in particular as a radial fan wheel, and is mounted so as to rotate on the stator and is connected for conjoint rotation with the rotor 5. An annular opening 17 of the air conveying element 14 is thereby covered on the rotor side by the rotor 5. The air conveying element 14 has a circumferential suction opening 16, which is open in the axial direction and which is fluidically connected to a circumferential exhaust opening 18, open in the radial direction, in the interior of the air conveying element 14. The suction opening 16 of the air conveying element 14 is opposite the through-flow opening 26 of the air guide element 22a, 22b, wherein the axial suction opening 16 of the air conveying element 14 opens into the axial through-flow opening 26 of the air guide element 22a, 22b by way of a sealing gap. In this regard, it is particularly advantageous that the air conveying element 14 has a funnel-shaped annular collar 29 on the side of the air guide element 22a, 22b at the edge of a circumferential wall of the suction opening 16, and that the air guide element 22a has a circumferential annular groove 33 on the side of the air conveying element 14 at the edge of the through-flow opening 26, the annular collar 29 projecting into the annular groove 33, and annular collar 29 and annular groove 33 forming the sealing gap. This enables the transition from the air guide element to the air conveying element to be fluidically optimized. The air conveying element 14 is configured such that it generates a negative pressure at its suction opening 16 during motor operation, and blows an air volume flow out radially at its exhaust opening 18.

On the side of the electronics housing 1, a circumferential flow gap 27 is formed radially between the air guide element 22a, 22b and the outer circumferential edge of the stator bushing 3 so that the flow space 35 is open in the direction of the mounting wall 11 on the side of the electronics housing 1. In the installed state, the flow gap 27 is covered axially, at least partially, by the mounting wall 11. In the region of the flow gap 27, the mounting wall 11 has at least one axially extending channel opening 28. On the outer circumference of the electronics housing 1, at least one air guide channel 20 is arranged on the side of the mounting wall 11 that is opposite the air guide element 22a, 22b, said air guide channel extending from the channel opening 28 of the mounting wall 11 in the direction of at least one region of the electronics housing 1 that is to be cooled on the outer circumference of the electronics housing 1. The air guide channel 20 can particularly be mounted on the mounting wall 11, and is particularly made of plastic. The air guide channel 20 has an annular circumferential attachment 21 at its end that abuts to the outer circumference of the electronics housing 1, which attachment is form-fitted, in particular, to the outer circumferential extension of the electronics housing 1, in particular of the housing cooling ribs 7. As a result, the attachment 21, together with the end of the air guide channel 20, covers a region of the housing cooling ribs 7 circumferentially, and forms a plurality of cooling channels extending between the housing cooling ribs 7. In this embodiment of the motor, a selected region of the electronics housing 1, covered by the end of the air guide channel 20 is cooled in a targeted manner. This is in particular the region in which the electronic components that are particularly to be cooled are arranged in the interior of the electronics housing 1. It is also conceivable, however, for a plurality of channel openings 28 to be arranged in the mounting wall 11 in a distributed manner over the circumference of the motor in the region of the flow gap 27 so that plurality of air guide channels 20 cool the plurality of regions of the electronics housing 1.

In the first embodiment shown in figure 1 and figure 2, the air guide element 22a can be mounted on the mounting wall 11 and is arranged between the mounting wall 11 and the air conveying element 14, with the suction opening 16 of the air conveying element 14 being aligned in the direction of the mounting wall 11. During motor operation, the air conveying element 14 generates a negative pressure in the

region of its suction opening 16 and in the region of the opposite through-flow opening 26 of the air guide element 22a. An air volume flow is drawn in via the flow space 35 and the air guide channel 20. In this case, the air volume flow flows first along the housing cooling ribs 7 of the electronics housing 1, where it absorbs heat from the electronics housing 1 and from the surface of the housing cooling ribs 7. As a result, the electronics housing 1 is cooled, which cools specific electronic components to be cooled, which are arranged in the electronics housing 1. The attachment 21 of the air guide channel 20 additionally increases the size of the suction path through the housing cooling ribs 7, thereby reinforcing the cooling effect. The air volume flow then flows through the air guide channel 20 and through the channel opening 28 in the mounting wall 11, and through the flow gap 27 into the flow space 35 and along the outer circumferential surface of the stator bushing 3, up to the through-flow opening 26 of the air guide element 22a, where it is drawn in axially by the air conveying element 14 at its suction opening 16, and is blown out radially in the region of the rotor 5 from the exhaust opening 18. By way of the circumferential flow space 35 and the circumferential suction opening 16 of the air conveying element 14, the air volume flow is distributed over the circumference of the stator bushing 3 for the purpose of cooling the stator bushing 3, and in particular is guided along the stator cooling ribs 8 of the stator bushing 3, where it absorbs heat from the stator and from the surface of the stator cooling ribs 8.

In the first embodiment of the invention, the cooling air volume flow is drawn in first in the region of the electronics housing 1 or through the air guide channel 20 on the outer circumference of the electronics housing 1. As a result, the air volume flow comes into contact with the electronics housing 1 first, so the electronics housing 1 is cooled particularly well. This is particularly advantageous if the ambient air has a lower temperature on the side of the electronics housing 1 than in the region of the rotor 5.

In the second embodiment shown in figure 3, the air guide element 22b can be mounted on the mounting wall 11, and the air conveying element 14 is arranged within the air guide element 22b, with the suction opening 16 of the air conveying element 14 aligned facing away from the mounting wall 11. The air guide element 22b also

surrounds the air conveying element 14. The air conveying element 14 is rotated 180° as compared with the first embodiment. This changes the flow direction of the air volume flow. During motor operation, the air conveying element 14 generates a negative pressure in the region of its suction opening 16 and in the region of the adjacent through-flow opening 26 of the air guide element 22b, and draws the air in axially in the region of the rotor 5, and blows the air out radially through the exhaust opening 18 and into the flow space 35. As a result, excess pressure is formed in the flow space 35, causing the air volume flow to flow along the outer circumferential surface of the stator bushing 3 and particularly along the stator cooling ribs 8 through the flow gap 27 and the channel opening 28 and the air guide channel 20, wherein it absorbs heat from the stator and from the surface of the stator cooling ribs 8, and cools the components of the stator. The air volume flow exits at the end of the air guide channel 20 at the outer circumference of the electronics housing 1, and is blown between the housing cooling ribs 7, thereby additionally cooling the electronics housing 1.

In the second embodiment of the invention, the cooling air volume flow is drawn in first in the region of the rotor 5. As a result, the air volume flow comes into contact first with the stator, so the stator is cooled particularly well. This is particularly advantageous if the ambient air has a lower temperature on the side of the rotor 5 than in the region of the electronics housing 1.

The invention is not limited to the exemplary embodiments depicted and described here, but rather comprises all embodiments that have the same effect as defined in the invention, as claimed in the accompanying claims.

Patentkrav

1. Motor, der er udformet som en yderrotormotor, og som omfatter et elektronikhus (1), en monteringsvæg (11), en stator med en statorbøsning (3) og en statorlamelleret kerne (4) med motorviklinger, en rotor (5) og et ringformet lufttransportelement (14), der på en drejefast måde er forbundet med rotoren (5), hvor motoren med statorbøsningen (3) er monteret på monteringsvæggen (11), der har en monteringsåbning (30), således at elektronikhuset (1) er lokaliseret på den ene side af monteringsvæggen (11), og statoren samt rotoren (5) er lokaliseret på den anden side af monteringsvæggen (11), og hvor elektronikhuset (1) har husafkølingsribber (7) på en ydre væg, hvilken motor endvidere omfatter et ringformet lufttransportelement (22a, 22b), der uafhængigt af motoren kan monteres på monteringsvæggen (11), hvor lufttransportelementet (22a, 22b) omgiver statorbøsningen (3), og der dannes et strømningsrum (35) mellem lufttransportelementet (22a, 22b), monteringsvæggen (11) og en ydre periferi af statorbøsningen (3), hvor strømningsrummet (35) er åbent på siden af elektronikhuset (1) ved hjælp af mindst én strømningsspalte (27) i retning af monteringsvæggen (11), og hvor lufttransportelementet (14) udmunder i en rotorsidig, periferisk gennemstrømningsåbning (26) i lufttransportelementet (22a, 22b) med en periferisk sugeåbning (16), som via en tætningsspalte er åben i aksial retning, og

hvilken motor endvidere omfatter mindst én lufttransportkanal (20), der er anbragt ved en ydre periferi af elektronikhuset (1), hvilken kanal er monteret på monteringsvæggen (11), hvor lufttransportkanalen (20) strækker sig fra mindst en aksialt forløbende kanalåbning (28) i monteringsvæggen (11), som er lokaliseret i strømningsspaltens (27) område, til et område, der skal afkøles, ved den ydre periferi af elektronikhuset (1).

2. Motor ifølge krav 1,

kendetegnet ved, at

lufttransportelementet (14) er udformet som et radiale ventilatorhjul.

3. Motor ifølge krav 1 eller 2,

kendetegnet ved, at

lufttransportelementet (22a) er anbragt med henblik på at kunne monteres på monteringsvæggen (11) og mellem monteringsvæggen (11) og lufttransportelementet (14), hvor sugeåbningen (16) i lufttransportelementet (14) er rettet ind i retning af monteringsvæggen (11).

4. Motor ifølge krav 1 eller 2,

kendetegnet ved, at

lufttransportelementet (22b) kan monteres på monteringsvæggen (11), og lufttransportelementet (14) er anbragt inde i lufttransportelementet (22b), hvor sugeåbningen (16) i lufttransportelementet (14) er rettet ind, så den vender væk fra monteringsvæggen (11).

5. Motor ifølge et hvilket som helst af kravene 1 til 4,

kendetegnet ved

en bærekonstruktion (10), der danner monteringsvæggen (11), og som omfatter monteringsåbningen (30), til modtagelse af elektronikhuset (1), hvor statorbøsningen (3) og lufttransportelementet (22a, 22b) er monteret på bærekonstruktionen (10), og hvor kanalåbningen (28) er anbragt radialt mellem statorbøsningen (3) og lufttransportelementet (22a, 22b) i bærekonstruktionen (10).

6. Motor ifølge et hvilket som helst af kravene 1 eller 5,

kendetegnet ved, at

lufttransportkanalen (20) har en ringformet periferisk fastgørelse (21), der ligger an mod den ydre periferi af elektronikhuset (1), hvilken fastgørelse formmæssigt er tilpasset til det ydre periferiske forløb af elektronikhuset (1).

7. Motor ifølge et hvilket som helst af kravene 1 til 6,

kendetegnet ved, at

husafkølingsribberne (7) tildækkes omkredsmæssigt ved hjælp af lufttransportkanalen (20).

8. Motor ifølge et hvilket som helst af kravene 1 til 7,

kendetegnet ved, at

statorbøsningen (3) har statorafkølingsribber (8) på den ydre væg, hvilke ribber tildækkes omkredsmæssigt ved hjælp af lufttransportelementet (22a, 22b).

9. Motor ifølge et hvilket som helst af kravene 1 til 8,

kendetegnet ved, at

lufttransportelementet (14) har en tragtformet ringkrave (29) på siden af lufttransportelementet (22a) ved randen af sugeåbningen (16), og lufttransportelementet (22a) har en periferisk ringformet rille (33) på siden af lufttransportelementet (14) ved randen af gennemstrømningsåbningen (26), hvor den ringformede krave (29) rager ind i den ringformede rille (33), og ringformet krave (29) og ringformet rille (33) danner tætningsspalten.

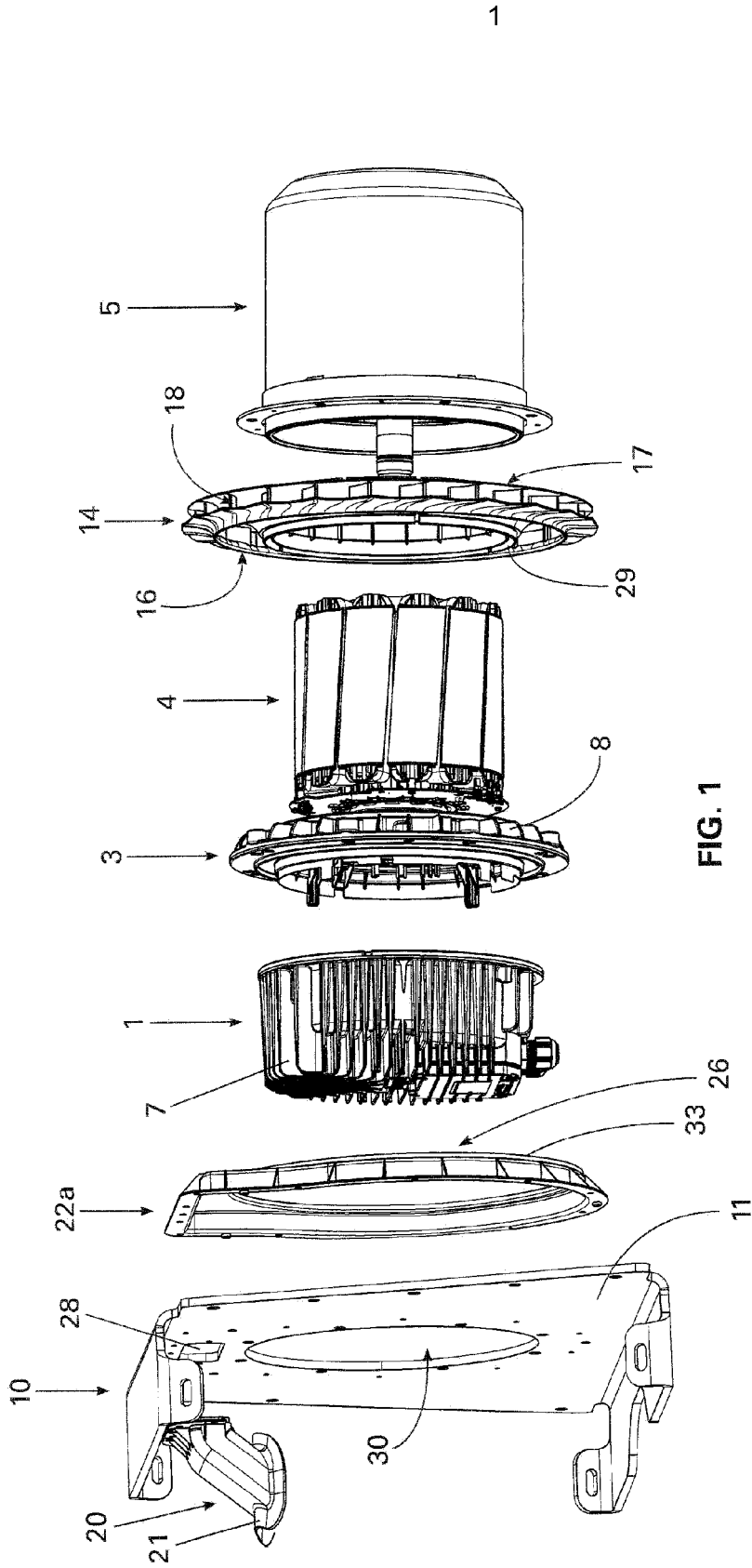

FIG. 1

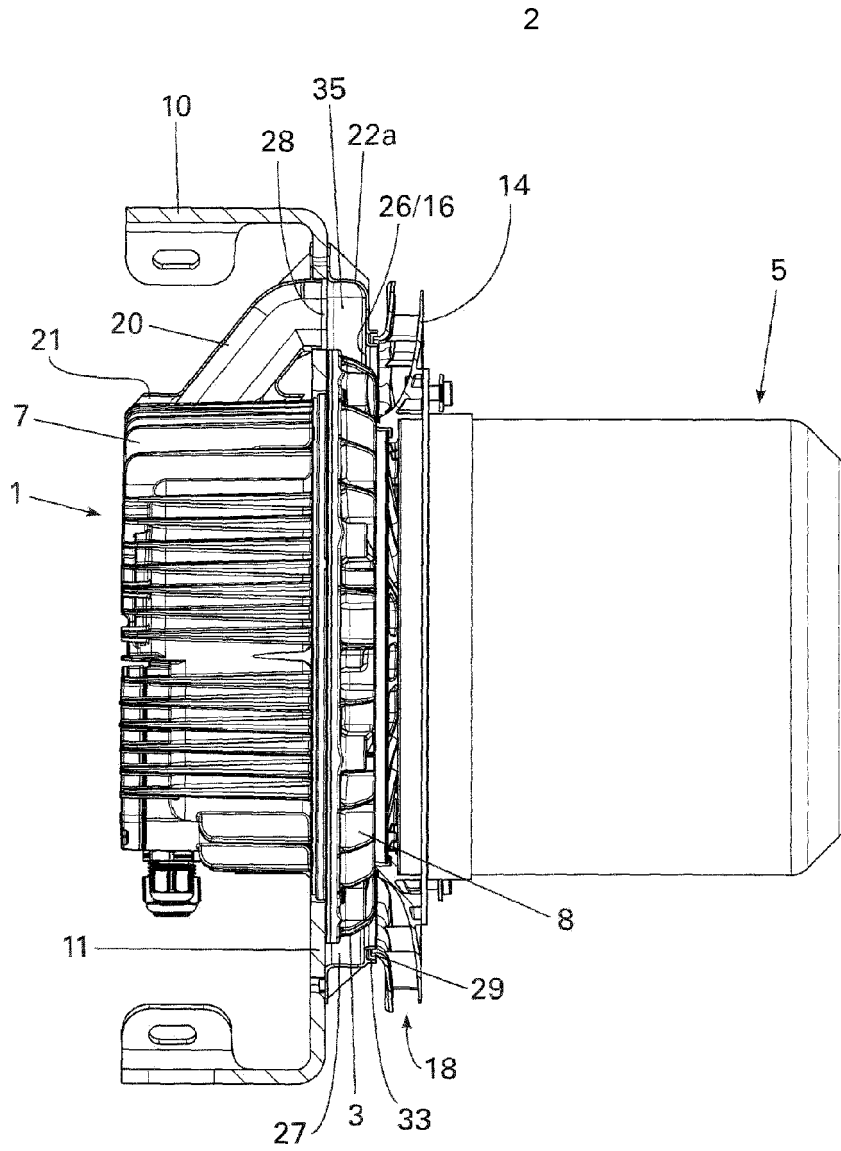

FIG. 2

