

(No Model.)

2 Sheets—Sheet 1.

R. H. BATH.
EXERCISING MACHINE.

No. 524,846.

Patented Aug. 21, 1894.

Fig. 1.

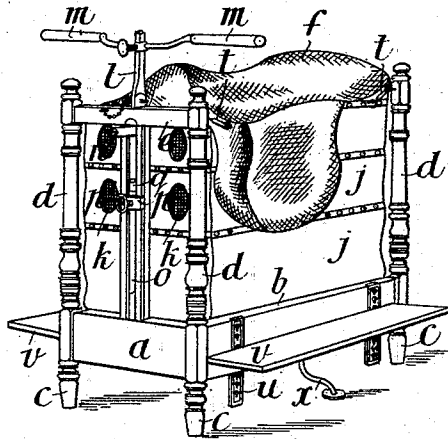

Fig. 2.

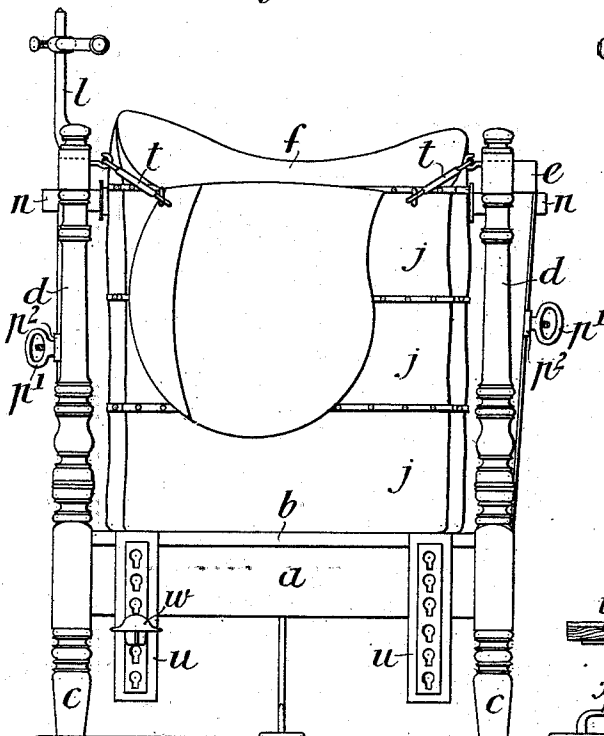
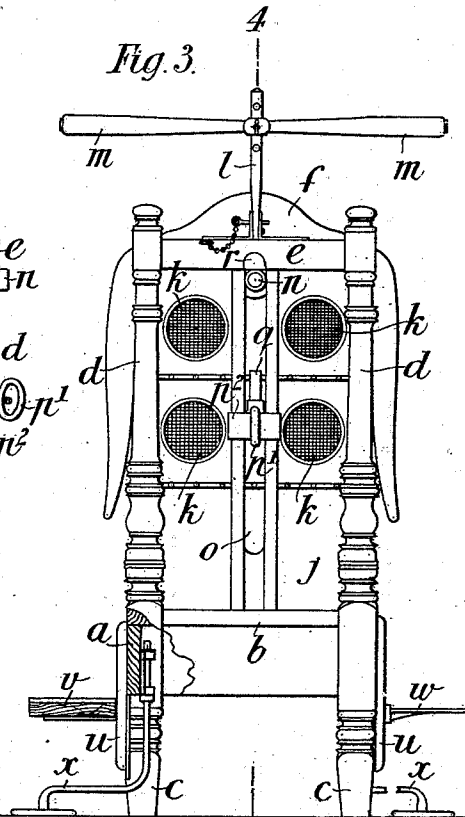

Fig. 3.



Witnesses

J. P. ...
John E. Dousfield.

4 Inventor.

R. H. Bath.

R. H. BATH.
EXERCISING MACHINE.

No. 524,846.

Patented Aug. 21, 1894.

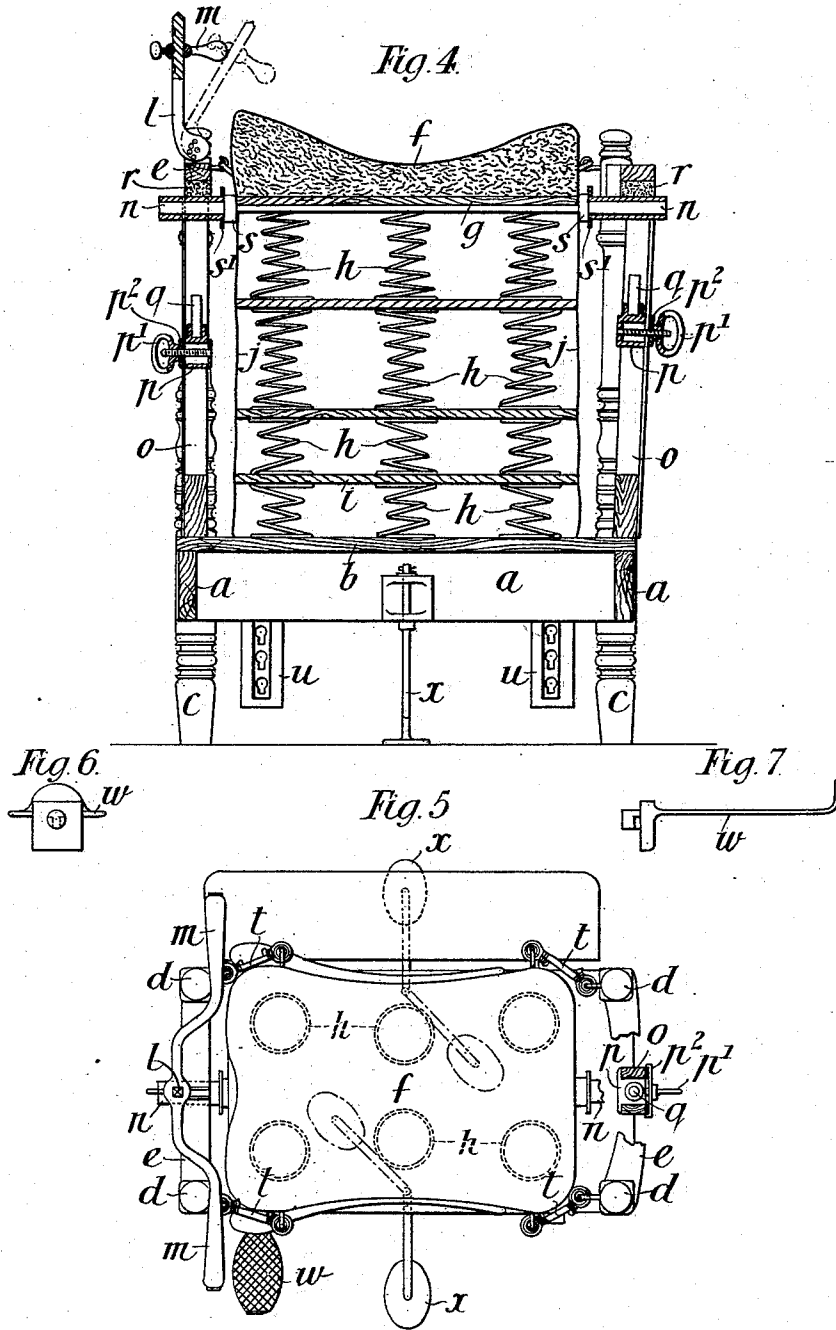

Witnesses.

G. H. H. H.
John E. Dousfield.

Inventor.

R. H. Bath.

UNITED STATES PATENT OFFICE.

RICHARD HENRY BATH, OF LONDON, ENGLAND.

EXERCISING-MACHINE.

SPECIFICATION forming part of Letters Patent No. 524,846, dated August 21, 1894.

Application filed March 28, 1894. Serial No. 505,422. (No model.)

To all whom it may concern:

Be it known that I, RICHARD HENRY BATH, a subject of the Queen of Great Britain, residing at London, England, have invented a new and useful Improved Exercising Apparatus, of which the following is a specification.

This invention relates to a novel and simple construction of apparatus to enable persons to obtain exercise similar to that obtained in horse riding.

In carrying out my invention I employ a saddle or seat mounted on springs in such a manner that the said saddle or seat can be moved up and down by the person using the apparatus, suitable guides being provided to limit the amount of play of the seat in any direction. In order to obtain the peculiar "bumping" effect obtained in horse riding, buffers are provided which are made adjustable so that the amount of bump may be regulated, and to further allow of such regulation I employ springs preferably in the form of rubber cords or bands.

Stirrups or foot-rests are attached to the apparatus to enable the person to operate the saddle or rest to obtain the required movement.

To enable my invention to be fully understood I will describe the same by reference to the accompanying drawings, in which—

Figure 1 is a perspective view of my improved exercising apparatus; and Figs. 2 and 3 are side and end elevations respectively of the said apparatus. Fig. 4 is a longitudinal section of the apparatus on the line 4—4, Fig. 3; and Fig. 5 is a plan. Figs. 6 and 7 are views of a detail hereinafter described.

a is the framing of the apparatus which supports a platform *b* and is provided with four legs *c, c* extended upward to form posts *d, d*, bars *e, e* connecting the front posts and back posts respectively near their upper ends.

f is the saddle which is carried upon a board *g* and mounted upon springs *h, h* upon the platform *b* in such a manner that when a person seated upon the saddle bumps upon the same the springs will be depressed and then react. As long springs, that is to say, continuous springs between the saddle and the platform would be liable to bulge laterally when depressed, I preferably employ short springs as shown in Fig. 4, the different sets

of short springs being separated by retaining boards *i, i*. These boards also serve for the attachment of a leather or other covering *j* around the springs. Openings *k, k* are formed in this cover and preferably filled with netting as shown in Fig. 3, in order to allow the escape and ingress of air during the motions of the saddle.

l is a standard pivoted to the front bar *e* and carrying handles *m* for the rider to grasp when exercising. By pivoting the standard *l* the handles may be adjusted toward or away from the rider, for instance, as indicated by dotted lines in Fig. 4.

In order that the saddle shall move vertically, guide-pins *n, n* are fixed to the front and rear of the saddle or to the board *g* carrying the same, and guides *o, o* are fixed between the plate *b* and the bars *e, e* in which the said pins *n, n* work.

In order to limit the extent to which the saddle shall be depressed when exercising, adjustable blocks *p, p* carrying india-rubber buffers *q, q* are arranged in the said guides *o, o*, the pins *n, n* striking against the said buffers which thus not only limit the downward movement of the saddle but also impart a certain amount of rebound thereto.

The said blocks *p, p* are advantageously provided with bolts whereby they can be clamped in position in the guides *o, o* by nuts *p', p'* and plates *p², p²*. By arranging the buffers *q, q* at different heights it is obvious that one pin *n* will strike its buffer before the other and thus impart a kind of trotting movement to the saddle. *r, r* are also buffers arranged at the upper ends of the guides *o, o* to limit the upward movement of the saddle and preferably made of elastic material to lessen the shock. By providing the saddle with only a single guide at each end I am enabled to obtain a rocking motion in addition to an up-and-down motion, the said pins *n, n* serving as the center of oscillation.

The pins *n, n* are provided with collars *s, s* and washers *s', s'* which prevent the saddle from touching the framing or the guides at either end.

t, t are auxiliary springs for use when required, the said springs being attached to hooks on the posts *d, d* and to other hooks upon the saddle, as shown most clearly in

Figs. 2 and 5, so as to allow of their being readily connected or disconnected.

u, u are brackets having a series of slotted holes for carrying foot-boards *v, v* the said foot-boards being provided with studs adapted to pass through the holes and enter the slots of the said brackets. Instead of using boards *v, v* I may use stirrups or foot-rests *w, w*, one of which is shown in end and side elevation respectively in Figs. 6 and 7; these foot-rests are also adapted to be carried by the brackets *u, u*. Or instead of using either foot-boards or rests I may provide the saddle with stirrups in the ordinary manner.

I may also, if desired, employ a saddle provided with a pommel to enable the apparatus to be used by ladies.

x, x are feet fixed to legs pivoted inside the frame *a* which feet, when turned outward as indicated in Figs. 3 and 5, steady the apparatus when in use.

It will be obvious that I may employ adjustable springs for allowing the apparatus to be regulated to suit different requirements.

I sometimes for instance when the apparatus is intended for use by children arrange in conjunction with the spring and other parts the representation of a horse, the saddle being upon the back of the same.

Having now particularly described and ascertained the nature of my said invention and in what manner the same is to be performed, I declare that what I claim is—

1. An exercising apparatus having a saddle provided with guide pins, spring supports for said saddle, vertical guides engaging said pins and elastic buffers adjustably secured to said guides in the path of said pins for limiting the vertical movements of the saddle, substantially as described.

2. An exercising apparatus having saddle supporting devices including two or more series of springs located in different horizontal

planes and retaining boards interposed between the springs of two adjacent series, substantially as described.

3. An exercising apparatus having saddle supporting devices including two or more series of springs located in different horizontal planes, retaining boards separating the springs of two adjacent series and a flexible covering secured to said boards, and provided with apertures for the egress and ingress of air, substantially as described.

4. In an exercising apparatus the combination with saddle supporting devices, including two or more series of springs located in different horizontal planes and retaining boards separating said series of springs, of adjustable foot supports, substantially as described.

5. In an exercising apparatus, the combination with the saddle and its supporting springs, of vertical guides for said saddle and elastic buffers for engaging parts connected with the front and rear of said saddle, and means for adjusting said buffers independently, whereby one of said buffers may be placed at a point higher than the other to impart a rocking movement to said saddle, substantially as described.

6. In an exercising machine the combination with the supporting frame and spring saddle supports, of the supplemental feet *x* pivoted to the main frame as described whereby said supplemental feet may be moved beneath the frame when not in use or may be swung outwardly to engage the floor at a distance from the frame, substantially as described.

RICHARD HENRY BATH.

Witnesses:

G. F. REDFERN,

JOHN E. BOUSFIELD,

Of the firm of G. F. Redfern & Co., 4 South Street, Finsbury, London, Patent Agents.