

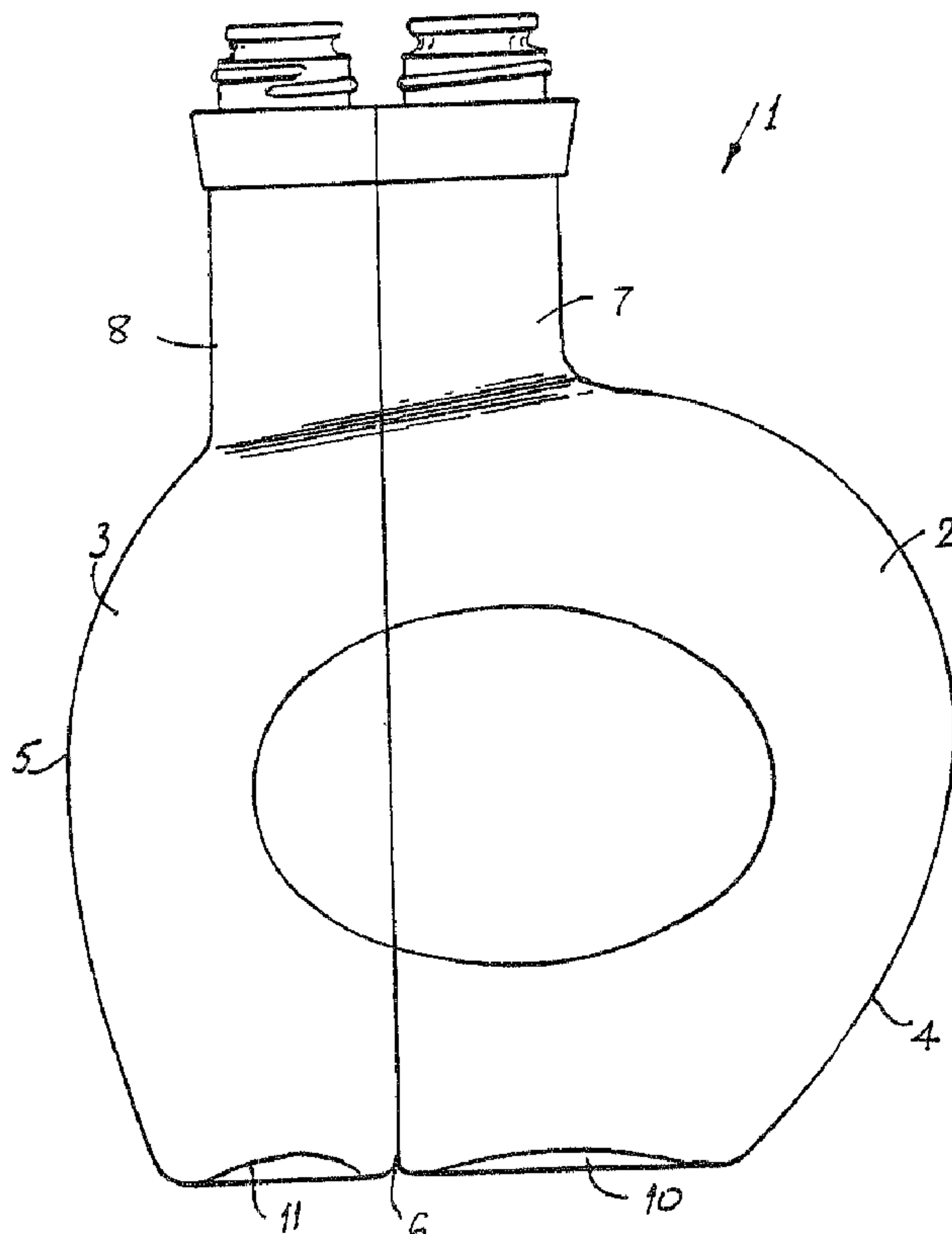

(22) Date de dépôt/Filing Date: 1993/08/16  
 (41) Mise à la disp. pub./Open to Public Insp.: 1994/09/06  
 (45) Date de délivrance/Issue Date: 2005/10/11  
 (30) Priorité/Priority: 1993/03/05 (93 0166) IE

(51) Cl.Int.<sup>5</sup>/Int.Cl.<sup>5</sup> B65D 81/32  
 (72) Inventeurs/Inventors:  
 RIGNEY, PATRICK, IE;  
 PURDY, COLIN, GB  
 (73) Propriétaire/Owner:  
 GILBEYS OF IRELAND (MANUFACTURING) LIMITED,  
 IE  
 (74) Agent: MOFFAT & CO.

(54) Titre : RECIPIENT POUVANT CONTENIR DEUX BREUVAGES  
 (54) Title: BEVERAGE CONTAINER FOR TWO BEVERAGES



(57) Abrégé/Abstract:

A beverage container 1 has two sub-compartments 2,3, the larger sub-compartment 2 containing a dark coloured liqueur and having a capacity of approximately twice that of the smaller compartment 3 which contains a white cream liqueur. The difference in specific gravity between the liqueurs is approximately 0.03g/litre so that the white liqueur floats on top of the dark liqueur when the liqueurs are poured into a glass.

ABSTRACT

5 A beverage container 1 has two sub-compartments 2,3, the larger sub-compartment 2 containing a dark coloured liqueur and having a capacity of approximately twice that of the smaller compartment 3 which contains a white cream liqueur. The difference in specific gravity between the liqueurs is approximately 0.03g/litre so that the white liqueur floats on top of the dark liqueur when the liqueurs are poured into a glass.

"Improvements in and relating to Beverages"

The invention relates to beverages and in particular to a beverage delivery system.

5 Beverage technology is concerned with the introduction of new liquid taste sensations by combining taste and flavour combinations in novel ways. In conventional systems a liquid beverage is provided as a single liquid with definite mouth feel and similar characteristics. There have been attempts to provide immiscible or non-homogenous liquids in a bottle, however, such systems require the consumer to mix the contents of the bottle prior to pouring to ensure that a homogenous product is delivered.

10 This invention is directed towards providing a novel system for delivering beverages.

15 According to the invention there is provided a liquid container having at least two separate compartments for different beverages which are to be poured to provide a combination product, the liquid beverages remaining substantially separate when the beverages are poured from the compartments into a receptacle.

20 In a particularly preferred embodiment of the invention there are two compartments in the container, a first beverage being poured from a first compartment into a receptacle and a second beverage being subsequently poured into the receptacle and remaining separate from the first beverage.

25 In an especially preferred embodiment of the invention the beverages have different specific gravities. Most

- 2 -

preferably the difference in specific gravity of the beverage is approximately 0.03g/litre.

5 In one embodiment of the invention the white beverage is a white cream liqueur. Preferably the white cream liqueur has a density of approximately 1.051 to 1.057. Typically the white ream liqueur includes alcohol, sugar syrup and a cream blend including dairy cream and caseinate.

10 In one embodiment of the invention the dark beverage includes a coffee flavour ingredient. Alternatively or preferably additionally the dark beverage includes a chocolate flavour ingredient. Preferably the dark beverage includes alcohol and sugar syrup. Most preferably the dark  
15 beverage has a density of apprroximately 1.0875 to 1.0950.

In an especially preferred embodiment of the invention the container comprises two attached sub-containers. In one  
20 embodiment of the invention the capacity of one of the sub-containers is approximately twice the capacity of the other sub-container.

In a broad aspect, then, the present invention relates to a liquid beverages container in combination with a dark  
25 beverage and a white cream liqueur beverage, the container comprising: a first compartment, a second compartment separate from the first compartment, the dark beverage being contained in the first compartment and having a density of from 1.085 to 1.0950 g/litre, the white cream liqueur  
30 beverage being contained in the second compartment and having a density of from 1.051 to 1.057g/litre, the difference between the specific gravities of the beverages being such that the dark beverage and the white cream liqueur beverage remain substantially separate when the

- 2a -

beverages are poured from the compartments into a receptacle.

5 The invention will be more clearly understood from the following description thereof given by way of example only with reference to the accompanying drawing which is an elevational view of a liquid container according to the invention.

10 Referring to the drawing there is illustrated a liquid container according to the invention indicated generally by the reference numeral 1. The liquid container 1 comprises two separate compartments 2, 3 defined by sub-containers 4, 5 respectively. The sub-containers 4, 5 may be formed  
15 separately and subsequently attached along a lateral joint 6. Each of the sub-containers 4, 5 is

provided with respective neck portions 7, 8 to be fitted with stoppers. In this case the capacity of the first compartment 2 is approximately twice the capacity of the second compartment 3 to accommodate different measures of the beverages.

5  
10  
15  
20  
Preferably the first compartment 2 contains a first dark beverage such as a dark coffee or chocolate liqueur beverage as will be described in more detail below. The second compartment 3 preferably contains a light coloured beverage such as a white cream liqueur as will also be described in more detail below. In use, a stopper is removed from the first compartment 2 and dark liqueur is poured into a suitably sized glass until the glass is approximately two thirds filled with the chocolate or coffee liqueur. The stopper is then replaced and a stopper is removed from the second compartment 3 allowing the white cream liqueur to be poured from the compartment 3 down the side of the glass. The white liqueur floats gently over the dark liqueur in the glass. The dark liqueur is sipped through the white cream liqueur giving a unique taste sensation. Thus, a single combination product may be delivered from a single bottle.

25  
The property used to achieve the essential characteristic of the invention which allows a white liquid to float on the surface of a dark liquid is to maintain sufficient difference between the specific gravities of the products to ensure complete separation when the white liqueur is poured down the side of a glass.

30  
We have found through extensive research and development that the differences in specific gravity must be maintained at approximately 0.03g/litre to ensure proper separation of the liqueurs in use.

The difference in specific gravities is dependent on the alcohol contents of the liqueurs, the sugar levels in the liqueurs and the fat content of the white cream liqueur.

5 In order to comply with regulations the alcohol content in both liqueurs must be greater than 15% v/v. The sugar levels are determined by the taste characteristics of the product. The fat levels in the cream liqueur that are manipulated to achieve the correct difference in specific gravities and hence the correct flotation of the white  
10 cream liqueur on the dark liqueur.

The formulations for the dark and white liqueurs are given in the following examples.

**EXAMPLE 1**

**Formulation for White Cream Liqueur Portion**

15	<b>Ingredients:</b>	<b>KG</b>
	Spirit at 96% alcohol	1953
	Sugar Syrup at 66° Brix	4125
	Water	958.8
	Natural Cream Flavour	29.4
20	Glycerol Monostearate	50
	<b>Cream Blend consisting of:</b>	
	Natural Dairy Cream	4440 kgs
	Sodium Caseinate	435 kgs
	Trisodium Citrate	25 kgs
25	Water	2150 kgs
		<u>7050</u>
	<b>Total:</b>	<b>14166 kgs</b>

**Processing:**

The product is produced in accordance with known cream liqueur technology.

5 Sodium Caseinate and Tri Sodium Citrate are solubilised and blended with fresh pasteurised cream, giving a cream base.

10 Glycerol monostearate is added to the cream base followed by alcohol flavours, sugar and water blend. The mix is homogenised at 50 - 60°C to reduce particle size and is finally cooled to approximately 20°C.

**Analysis of Final Product - White Cream Liqueur**

Alcohol content	:	17% v/v
Fat % w/w	:	14.9% - 15.5%
Viscosity (Secs)	:	63 - 70
15 pH	:	6.9 - 7.0
Density	:	1.051 - 1.057 @ 20°C
Sugars	:	20% w/w

**EXAMPLE 2****Formulation for Black Coffee/Chocolate Liqueur****20 Ingredients:**

Batch Size 3,000 Litres	KG
Alcohol (96%)	667.0
Sugar Syrup (66° Brix)	1431.0
Coffee Flavour	39.6
25 Chocolate Flavour	78.5
Natural Vanilla	14.5
Caramel	5.7
Water	<u>973.5</u>
	3209.0

## Processing

### Black Liquid

5 The alcohol, sugar and water are blended in their respective proportions, followed by the flavours and colour ingredients. The liquid is then agitated to ensure uniform mix and is finally filtered.

### Analysis of Final Product - Black Coffee Flavour

Alcohol Content	26% v/v
Sugars	31% w/v
10 pH	4.9 - 5.1
Density	1.0875 - 1.0950 @ 20°C

15 The invention provides a beverage system which allows variations in taste sensations to be introduced by combining various liquids with different mouth feels and other characteristics which are not available using a single compartment bottle. Similarly, colour variations and combinations other than a single coloured product may be used because of the dual compartment bottle container.

20 Because the two liqueurs are provided in a single container they may be readily dispensed in the correct proportions even by a busy barman. An approximate indicator that the correct amount of liqueur has been dispensed from each compartment is provided by the levels of the liquid remaining in the compartments. As measures  
25 of the liqueurs are poured from the compartment the levels of the liquid remaining in the compartment drop at the same rate.

Many variations on the specific embodiment of the invention described will be readily apparent and accordingly the invention is not limited to the embodiment hereinbefore described which may be varied in both  
5 construction and detail.

THE EMBODIMENTS OF THE INVENTION IN WHICH AN EXCLUSIVE PROPERTY OR PRIVILEGE IS CLAIMED ARE DEFINED AS FOLLOWS:

1. A liquid beverages container in combination with a dark  
5 beverage and a white cream liqueur beverage, the  
container comprising:  
a first compartment,  
a second compartment separate from the first  
compartment,  
10 the dark beverage being contained in the first  
compartment and having a density of from 1.085 to  
1.0950 g/litre,  
the white cream liqueur beverage being contained in the  
second compartment and having a density of from 1.051  
15 to 1.057g/litre,  
the difference between the specific gravities of the  
beverages being such that the dark beverage and the  
white cream liqueur beverage remain substantially  
separate when the beverages are poured from the  
20 compartments into a receptacle.
2. A liquid beverages container in combination with a dark  
beverage and a white cream liqueur as claimed in claim  
1 wherein the difference in specific gravity of the  
25 beverages is approximately 0.03g/litre.
3. A liquid beverages container in combination with a dark  
beverage and a white cream liqueur beverage as claimed  
in claim 1 or claim 2 wherein the white cream liqueur  
30 includes alcohol, sugar syrup and a cream blend  
including dairy cream and caseinate.
4. A liquid beverages container in combination with a dark  
beverage and a white cream liqueur beverage as claimed

in any one of claims 1 to 3 wherein the dark beverage includes a coffee flavour ingredient.

- 5 5. A liquid beverages container in combination with a dark beverage and a white cream liqueur beverage as claimed in any one of claims 1 to 3 wherein the dark beverage includes a chocolate flavour ingredient.
- 10 6. A liquid beverages container in combination with a dark beverage and a white cream liqueur beverage as claimed in claim 4 wherein the dark beverage includes alcohol and sugar syrup.
- 15 7. A liquid beverages container in combination with a dark beverage and a white cream liqueur beverage as claimed in any one of claims 1 to 6 wherein the first compartment is defined by a first bottle and the second compartment is defined by a second bottle attached to the first bottle.
- 20 8. A liquid beverages container in combination with a dark beverage and a white cream liqueur beverage as claimed in claim 7 wherein the capacity of one of the bottle is approximately twice the capacity of the other bottle.

2104171

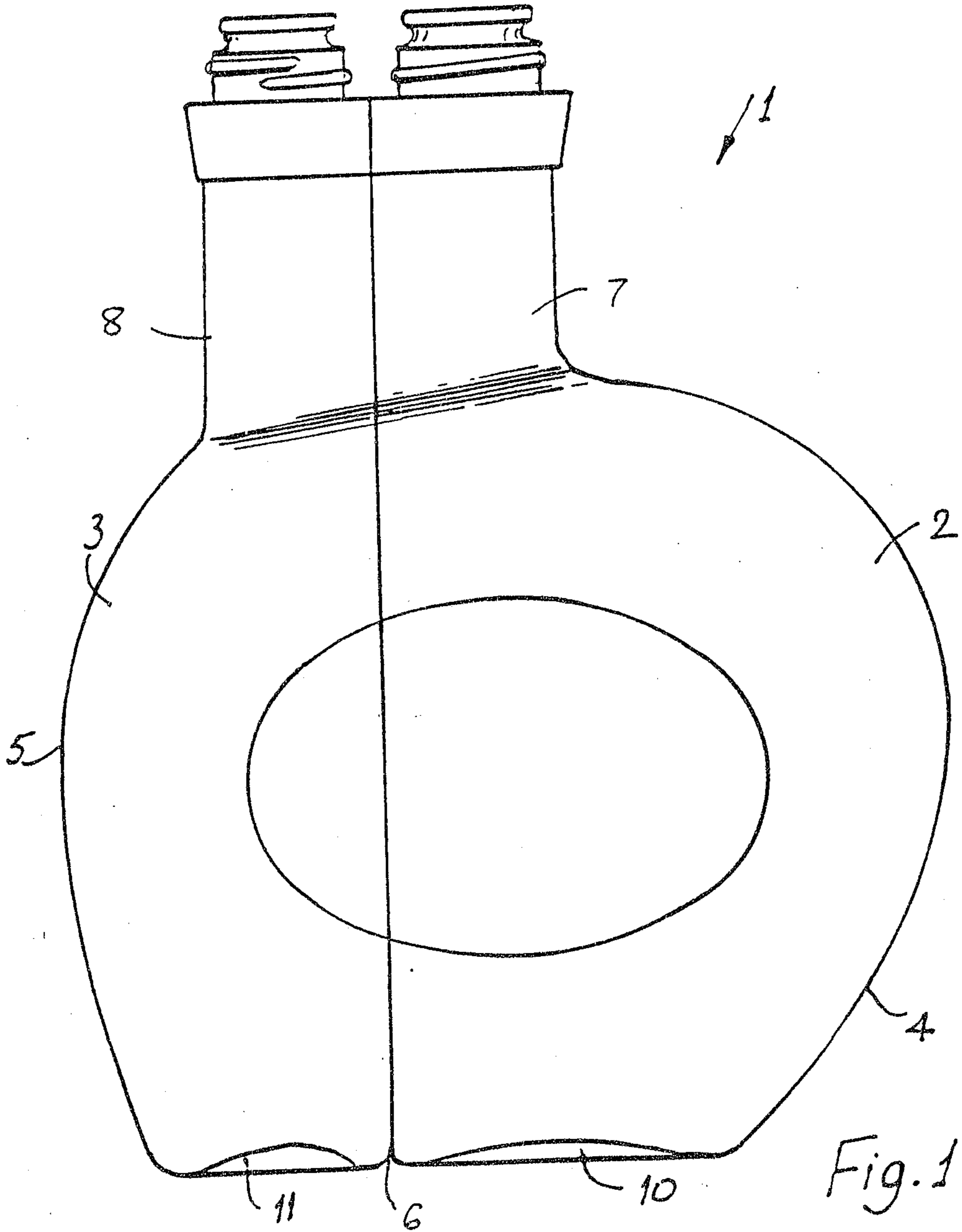

Fig. 1

