

*Ball & Fitts.*

*Water Meter.*

*No. 109,372.*

*Patented Nov. 22, 1870.*

*Fig. 2.*

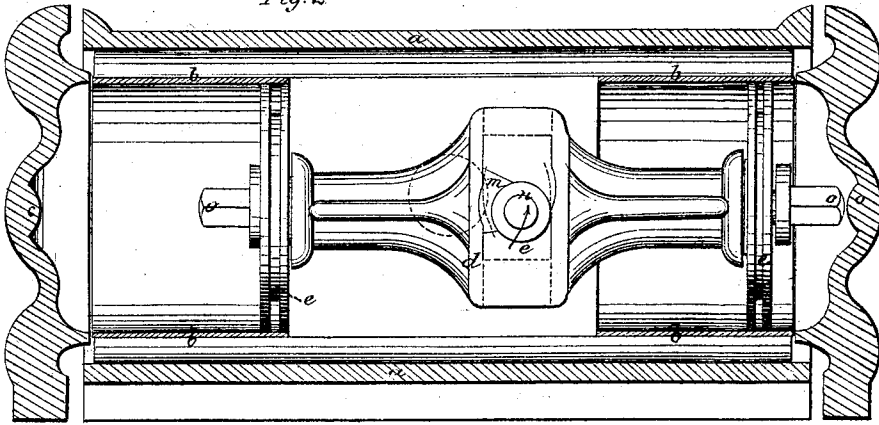

*Fig. 1.*

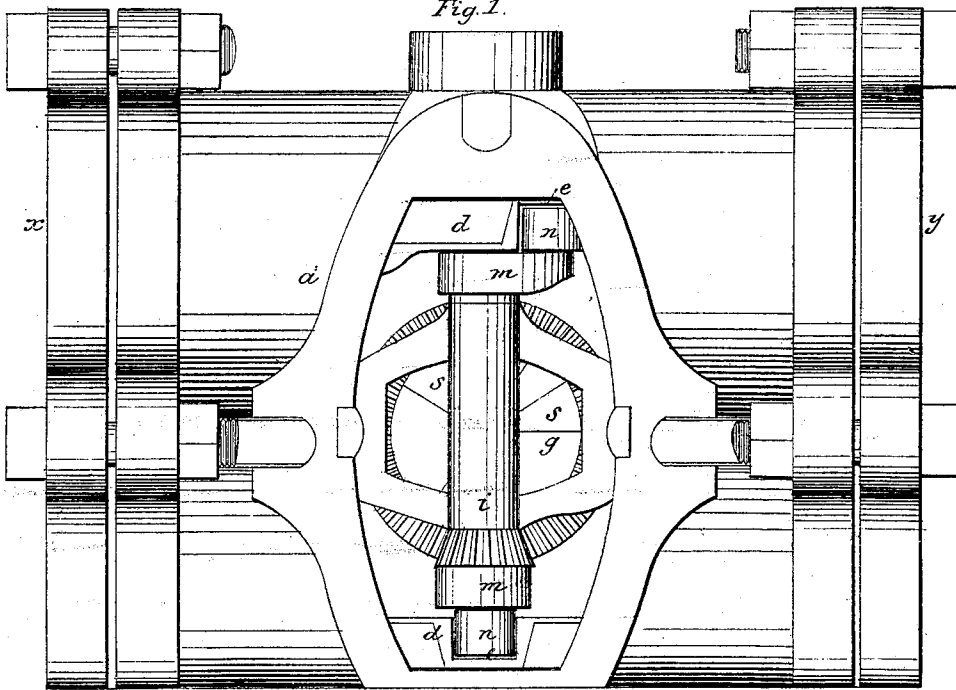

Witnesses

*John C. Otis*  
*Abraham Fitts*

Inventors

*Pinchas Ball*  
*Benaiah Fitts*

# UNITED STATES PATENT OFFICE.

PHINEHAS BALL AND BENAI AH FITTS, OF WORCESTER, MASSACHUSETTS.

## IMPROVEMENT IN LIQUID-METERS.

Specification forming part of Letters Patent No. **109,372**, dated November 22, 1870.

*To all whom it may concern :*

Be it known that we, PHINEHAS BALL and BENAI AH FITTS, of the city and county of Worcester, and State of Massachusetts, have invented a new and useful Improvement in Water-Meter; and we do hereby declare that the following is a full, clear, and exact description of the construction and operation of the same, reference being had to the annexed drawings, making a part of this specification, in which—

Figure 1 is a plan, a portion of the machine being removed to show the inside. Fig. 2 is a sectional view through *x y*, Fig. 1.

It will be seen that this meter is similar in its operation to that patented by P. Ball and B. Fitts, July, 1869, the principal difference being in the slots in the connecting-rods, in which crank-pins move, and it is these slots, in connection with stops at the end of the cylinders, that constitute the peculiar features of this invention.

The construction is as follows: *a* is the outside case. *b b* are cylinders set in cement. *c c* are pistons. *d d* are connecting-rods connecting the pistons together. *e* is a slot in the connecting-rods. It will be seen that the sides of this slot are not parallel or straight, the slots being wider in the middle than at the ends. *g* is a valve. *i* is the shaft. *m* is a crank; *n*, a crank-pin, which moves in slot *e*. *o o* are stops for the purpose of stopping the pistons when they reach the end of the stroke. *s s* are ports through the valve, the pistons, shaft, and valve being so connected together

that the valve-ports will be open when the piston is in the center of the stroke, and closed at the end of the stroke.

The operation is as follows: As the water flows in and moves the piston it will be seen that by the peculiar form of slot *e* the piston reaches the end of the stroke and stops a little before the crank passes the center, (shown by the position in Fig. 2,) or the valve-ports quite close. The opposite piston then moves the valve over, and opens it to the other side of the piston before the crank-pin reaches the point to where the first piston would be compelled to move, and thus in no case would one piston force the other to move while its valve is closed.

Thus having set forth our invention, what we claim as new, and desire to secure by Letters Patent, is—

1. The piston carrying connecting-rods *d*, having slots formed, as shown, with concavities to the right and left of the center, in combination with stops *o o*, substantially as set forth, and operating as described.

2. The piston carrying connecting-rods *d*, having slots formed, as shown, in combination with crank *m* and crank-pin *n*, constructed and operating substantially as set forth and described.

PHINEHAS BALL.  
BENAI AH FITTS.

Witnesses:

JOHN C. OTIS,  
ABRAHAM FITTS.