



INTERNATIONAL APPLICATION PUBLISHED UNDER THE PATENT COOPERATION TREATY (PCT)

<p>(51) International Patent Classification ⁷ : G09G 3/32</p>	<p>A1</p>	<p>(11) International Publication Number: WO 00/43981</p> <p>(43) International Publication Date: 27 July 2000 (27.07.00)</p>
<p>(21) International Application Number: PCT/EP99/10404</p> <p>(22) International Filing Date: 24 December 1999 (24.12.99)</p> <p>(30) Priority Data: 99200181.8 21 January 1999 (21.01.99) EP</p> <p>(71) Applicant: KONINKLIJKE PHILIPS ELECTRONICS N.V. [NL/NL]; Groenewoudseweg 1, NL-5621 BA Eindhoven (NL).</p> <p>(72) Inventors: VAN VELZEN, Jeroen; Prof. Holstlaan 6, NL-5656 AA Eindhoven (NL). LIEDENBAUM, Coen, T., H., F.; Prof. Holstlaan 6, NL-5656 AA Eindhoven (NL).</p> <p>(74) Agent: RAAP, Adriaan, Y.; Internationaal Octrooibureau B.V., Prof. Holstlaan 6, NL-5656 AA Eindhoven (NL).</p>	<p>(81) Designated States: CN, JP, European patent (AT, BE, CH, CY, DE, DK, ES, FI, FR, GB, GR, IE, IT, LU, MC, NL, PT, SE).</p> <p>Published <i>With international search report. Before the expiration of the time limit for amending the claims and to be republished in the event of the receipt of amendments.</i></p>	

(54) Title: ORGANIC ELECTROLUMINESCENT DISPLAY DEVICE

(57) Abstract

Electroluminescent display device comprising drive circuitry (a number of alternatives is given) to determine the surface area of a pixel (via capacitance, reverse current) and adjust the current density in the pixel accordingly.

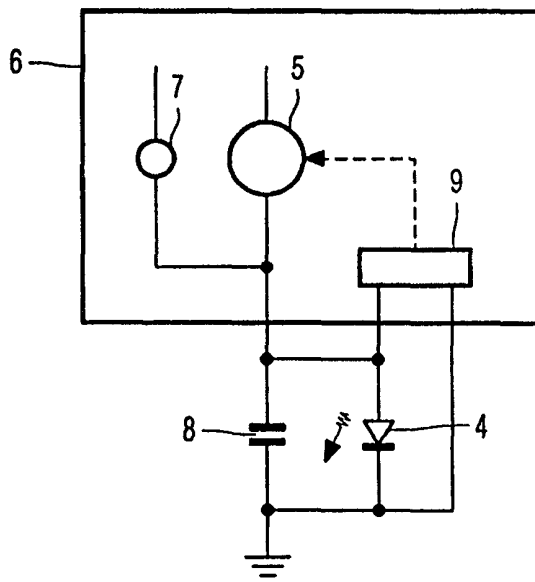

FOR THE PURPOSES OF INFORMATION ONLY

Codes used to identify States party to the PCT on the front pages of pamphlets publishing international applications under the PCT.

AL	Albania	ES	Spain	LS	Lesotho	SI	Slovenia
AM	Armenia	FI	Finland	LT	Lithuania	SK	Slovakia
AT	Austria	FR	France	LU	Luxembourg	SN	Senegal
AU	Australia	GA	Gabon	LV	Latvia	SZ	Swaziland
AZ	Azerbaijan	GB	United Kingdom	MC	Monaco	TD	Chad
BA	Bosnia and Herzegovina	GE	Georgia	MD	Republic of Moldova	TG	Togo
BB	Barbados	GH	Ghana	MG	Madagascar	TJ	Tajikistan
BE	Belgium	GN	Guinea	MK	The former Yugoslav Republic of Macedonia	TM	Turkmenistan
BF	Burkina Faso	GR	Greece			TR	Turkey
BG	Bulgaria	HU	Hungary	ML	Mali	TT	Trinidad and Tobago
BJ	Benin	IE	Ireland	MN	Mongolia	UA	Ukraine
BR	Brazil	IL	Israel	MR	Mauritania	UG	Uganda
BY	Belarus	IS	Iceland	MW	Malawi	US	United States of America
CA	Canada	IT	Italy	MX	Mexico	UZ	Uzbekistan
CF	Central African Republic	JP	Japan	NE	Niger	VN	Viet Nam
CG	Congo	KE	Kenya	NL	Netherlands	YU	Yugoslavia
CH	Switzerland	KG	Kyrgyzstan	NO	Norway	ZW	Zimbabwe
CI	Côte d'Ivoire	KP	Democratic People's Republic of Korea	NZ	New Zealand		
CM	Cameroon			PL	Poland		
CN	China	KR	Republic of Korea	PT	Portugal		
CU	Cuba	KZ	Kazakistan	RO	Romania		
CZ	Czech Republic	LC	Saint Lucia	RU	Russian Federation		
DE	Germany	LI	Liechtenstein	SD	Sudan		
DK	Denmark	LK	Sri Lanka	SE	Sweden		
EE	Estonia	LR	Liberia	SG	Singapore		

Organic electroluminescent display device.

The invention relates to an electroluminescent display device comprising a layer of electroluminescent material with an active layer of an organic material, which layer is present between a first and a second pattern of electrodes, which patterns define pixels having a different surface area, at least one of the two patterns being transparent to light to be emitted
5 through the active layer, and a first pattern comprising a material which is suitable for injecting charge carriers by means of a bias current for emitting, the display device comprising drive means for adjusting the bias current of a pixel.

Electroluminescent (EL) display devices may be used in, for example, displays
10 and indicator lamps. An increasing number of organic materials such as, for example, semiconducting organic polymers is used for the active layer in such structures. This increases the number of possible materials for use in these types of display devices. The active layer and the two electrode layers (the electroluminescent display device) preferably comprise a plurality of LEDs, for example, in the form of light-emitting surfaces arranged as segments or
15 matrices, as intended for a display device described in, for example, WO 96/36959 (PHN 15.320), or combinations thereof.

The operation is based on the recombinations of electron hole pairs which are injected into the semiconductor material (during use in the forward direction) from electrodes situated on both sides of the active layer. Due to these recombinations, energy is released in
20 the form of (visible) light, a phenomenon referred to as electroluminescence. The wavelength and hence the color of the emitted light is also determined by the bandgap of the (semiconductor) material.

Notably when using these types of display devices with pixels having a
25 different area, problems arise in realizing the desired brightness at a given signal. The input signal is generally used for controlling a current source which generates a current through the LED (the pixel). The brightness (luminance) of such a pixel is, however, dependent on the density of the current through such a pixel. When using the same current through LEDs with a

different surface area, a difference in surface area leads to a difference in the current density and hence to a difference in luminance.

5 It is, inter alia, an object of the present invention to obviate one or more of the above-mentioned drawbacks.

To this end, a luminescent display device according to the invention is characterized in that the drive means comprise means for varying the current density of the bias current in dependence upon a surface area of a pixel.

10 The invention is based on the recognition that different electrical parameters (capacitance, current density) are dependent on the surface area of a pixel and may therefore be used as feedback parameters for adjusting the correct bias current.

A preferred embodiment of a luminescent display device according to the invention is therefore characterized in that the drive means comprise means for defining the capacitance of a pixel.

15 This may be realized in a simple manner by means of a (small-signal) alternating current. A first embodiment is therefore characterized in that the means for defining the capacitance of a pixel comprise means for adding a (small-signal) alternating current to the bias current of the pixel and for measuring the associated (small-signal) alternating voltage.

20 In addition, the capacitance of a pixel may be defined by means of, for example, a sample-and-hold method, in which a pixel (segment) is supplied with a fixed measuring current and the voltage caused by the measuring current across the pixel is fixed. The measuring current is preferably supplied within a measuring period in which the voltage across the pixel remains limited to a value below the threshold value of the pixel.

25 The means for defining the capacitance of a pixel may alternatively comprise means for applying a voltage pulse across a pixel and for defining the decay time of the current through the pixel. The measured decay time is then compared, for example, with the decay time of a reference circuit.

30 Another possibility of defining the capacitance of a pixel makes use of the resonance frequency of a circuit of which the pixel forms part.

Another embodiment of a luminescent display device according to the invention makes use of current measurement. This embodiment is characterized in that the electroluminescent display device comprises at least two pixels having a different surface area, and drive unit means for applying a voltage in the reverse direction across the pixels, and

means for defining the reverse current. This embodiment is notably, but not exclusively, suitable for a luminescent display device driven in a multiplex mode.

These and other aspects of the invention are apparent from and will be elucidated with reference to the embodiments described hereinafter.

5

In the drawings:

Fig. 1 is a diagrammatic cross-section of a part of a display device to which the invention is applicable,

10

Fig. 2 shows diagrammatically a pixel and a part of the associated measuring circuit,

Fig. 3 shows the current/voltage characteristic of a LED,

Fig. 4 shows diagrammatically a pixel with a part of another measuring circuit,

15

Fig. 5 shows the current-time behavior in the circuit of Fig. 4 for pixels having a different surface area,

Fig. 6 shows diagrammatically a pixel with a part of another measuring circuit, while

Fig. 7 shows the switching patterns and some voltages associated with the circuit of Fig. 6, and

20

Fig. 8 shows diagrammatically a pixel with a part of another measuring circuit.

The Figures are diagrammatic and not drawn to scale. Corresponding elements are generally denoted by the same reference numerals.

Fig. 1 shows a display device 1 with an active layer 5 between two patterns of electrode layers 2, 3 of electrically conducting materials. In this example, the electrodes 2 with the electrodes 3 and the interpositioned active material define light-emitting diodes (LEDs) 4, also referred to as pixels. At least one of the electrode patterns is transparent to the emitted light in the active layer. During operation, the electrodes 2 are driven in such a way that they have a sufficiently positive voltage with respect to the electrodes 3 for the injection of holes into the active layer. The material of these electrodes 2 has a high work function and is usually constituted by a layer of indium oxide or indium-tin oxide (ITO). Particularly ITO is suitable due to its satisfactory electric conductivity and high transparency. The electrodes 3 serve as negative electrodes (with respect to the electrodes 2) for the injection of electrons into the active layer. In this example, the material for this layer is aluminum.

The light intensity of the LED (the pixel) 4 depends on the current density. The pixels 4 are driven in this example by means of diagrammatically shown current sources 5 which are integrated in the drive unit 6. At an equal luminance of, for example, the pixels 4^a and 4^b and without special measures, the current sources 5^a, 5^b will supply the same current.

5 Since pixel 4^a has a larger surface area than pixel 4^b, the density of the current through pixel 4^a will be smaller than the density of the current through pixel 4^b. To preclude adjustment of the drive unit 6 for each and every different combination of pixels, it is provided, in accordance with the invention, with means for defining the surface area of the pixels to be driven, so that, during operation, a current density can be adapted to the surface area of a pixel to be driven.

10 In a first variant, the current supplied by the driver implemented as current source 5 is modulated around the adjusting point by means of an AC source 7. The AC current has such a low amplitude i that the adjusting point of the current/voltage characteristic associated with the LED 4 does not change or hardly changes so that the differential resistance r_d does not change. Simultaneously, the associated small-signal AC voltage u is measured in
15 the drive unit 6. For the current i it holds that

$$i = u \cdot \left(\frac{1 + j\omega C r_d}{r_d} \right)$$

Here, r_d is the differential resistance at, for example, the point 10 (Fig. 3) of the
20 current/voltage characteristic of the LED 4. For high frequencies ($\omega \gg 1/Cr_d$) it holds that $i = u \cdot j\omega C$ or $u = -ji/\omega C$.

By modulating the current source 5 with a small-signal AC current i , the amplitude u of the AC voltage generated thereby can be measured, for example, with a high-ohmic volt meter 9 which is integrated in the drive unit 6. For the measured voltage, it now
25 holds that this is inversely proportional to the capacitance of the LED 4 (diagrammatically shown in Fig. 2 by means of the capacitor 8). ($u = -ji/\omega C$). The desired current density is then adjusted in the drive unit 6 with reference to the measured voltage.

In the embodiment of Fig. 4, the delay time is measured of an RC network in which the LED 4 and the associated capacitor 8 are incorporated. Via a switch 11, a resistor 12
30 is incorporated in the current path and the delay time (RC time) is measured. The delay time is determined, for example, by comparing the current through a pixel with that of a comparison

circuit comprising a resistor 12^a having the same resistance as the resistor 12, and a reference capacitor 14. The pixel and the comparison circuit are, for example, driven simultaneously with an identical voltage pulse (generated via a voltage source 17), while the current source 5 is switched off. For example, the instant t_1 can then be determined, at which instant the current through the LED 4 (curve 15 in Fig. 5) is identical to the current through the reference capacitor 14 (curve 16 in Fig. 5). These currents may be measured, for example, via the voltage across the resistors 15 by means of high-ohmic volt meters (not shown) in the drive unit 6.

Figs. 6 and 7 show how a difference in capacitance and hence surface area can be defined with a sample-and-hold circuit which is added to the current source 5. In this example, this circuit comprises four switches 19(s_1, s_2, s_3, s_4), an operational amplifier 18 and an auxiliary current source 20 and a capacitor 21 (see Fig. 6). The pixel, represented by the LED 4 and the capacitor 8, can be connected to the current source 5 via the switch s_4 and is connected at the other end to the non-inverting input of the operational amplifier 18, which input can be connected to ground or to the auxiliary current source 20, dependent on the position of the switches s_1, s_2 . The inverting input of the operational amplifier 18 is connected to a positive voltage. Its output can be connected to the capacitor 21 via the switch s_3 . The voltage across this capacitor (U_{sh}) defines the current through the current source 5 ($I = k \cdot U_{sh}$). Possible non-linearities of the capacitance may be processed in k as a function of the voltage. This notably applies to smaller capacitances.

Fig. 7 shows the behavior as a function of time (the position of the switches, as well as the voltages U_{sh} and U_{pix} , the voltage across the pixel). At the instant $t = t_0$, switch s_1 is closed and switch s_4 is opened. The pixel 4 is, as it were, short-circuited thereby (reset) and U_{pix} becomes 0 volt. At the instant $t = t_1$, switch s_1 is opened while the switches s_2, s_3 are closed. Due to a constant (measuring) current supplied by the auxiliary current source 20, the voltage across the pixel (segment) increases linearly in accordance with $dV = \frac{I(t) \cdot dt}{C}$. The measuring time (the period $t_1 - t_2$) is chosen to be sufficiently small to cause the LED 4 not to convey current (U_{pix} remains below the threshold voltage). Via the operational amplifier, a voltage U_{sh} is obtained at the capacitor 21, which voltage is higher when $t = t_2$, as U_{pix} is higher (hence C is smaller). At the instant t_2 , the switches s_2, s_3 are opened again. The voltage U_{sh} across the capacitor 21 is thereby fixed. Simultaneously, the switch s_4 is closed. The voltage U_{sh} directly influences the current of the current source 5 and hence the density of the current through the LED 4.

The device of Fig. 8 makes use of a current source 5 whose operating frequency may be varied. A coil 22 with an inductance L is arranged in the drive unit 6 between the current source 5 and the LED 4. To define the capacitance (and hence the surface area) of the pixel, the operating frequency is varied until resonance occurs. The value of C is derived again
 5 from the resonance frequency $\omega = 1/\sqrt{LC}$, of course after correction of capacitances in the measuring circuit.

Another value which is dependent on the surface area of the LED is the reverse current or I_{rev} . To be able to measure this value, at least two LEDs should be driven by the same current source. In contrast to the previous embodiments, which are based on the use of
 10 one current source per LED, this embodiment is suitable for multiplex applications.

To this end, the electroluminescent elements are driven in this embodiment by the same current source by means of multiplexing. In this mode, a zero voltage is applied between the electrodes 2 and 3 of one of the LEDs associated with the current source, while a reverse voltage $-V_b$ is applied across the other LEDs and the current thus generated is
 15 measured. The measured current value is, for example, digitized in the drive unit 6. The values found are subsequently used for computing the densities of the currents to be adjusted, which currents must flow through each electroluminescent element (the LEDs) to obtain a uniform luminance. In the case of 1:4 multiplexing, it holds for the four current measurements (I_1 of the first measurement, I_2 of the second measurement, etc.) for the measured reverse current

20 I_{rev} :

$$I_1 = I_{rev2} + I_{rev3} + I_{rev4}$$

$$I_2 = I_{rev1} + I_{rev3} + I_{rev4}$$

$$I_3 = I_{rev1} + I_{rev2} + I_{rev4}$$

$$I_4 = I_{rev1} + I_{rev2} + I_{rev3}$$

25 or:

$$I_{rev1} = 1/3 (I_1 + I_3 + I_4 - 2I_2)$$

$$I_{rev2} = 1/3 (I_1 + I_2 + I_4 - 2I_3)$$

$$I_{rev3} = 1/3 (I_2 + I_3 + I_4 - 2I_1)$$

$$I_{rev4} = 1/3 (I_1 + I_2 + I_3 - 2I_4)$$

30

In the drive unit 6, the adaptation thus found is measured either during operation and, if necessary, corrected, or is realized in advance with the aid of a look-up table. The measurement preferably takes place by using a current source 4 (multiplexing), but is alternatively possible via separate current sources 4.

In summary, the invention provides a plurality of circuits for an electroluminescent display device so as to define the surface area of a pixel (capacitively or via current measurement) and to adapt the density of the current through the pixel on the basis of the measuring result.

- 5 The invention relates to each and every novel characteristic feature and each and every combination of characteristic features.

CLAIMS:

1. An electroluminescent display device comprising a layer of electroluminescent material with an active layer of an organic material, which layer is present between a first and a second pattern of electrodes, which patterns define pixels having a different surface area, at least one of the two patterns being transparent to light to be emitted through the active layer,
5 and a first pattern comprising a material which is suitable for injecting charge carriers by means of a bias current for emitting, the display device comprising drive means for adjusting the bias current of a pixel, characterized in that the drive means comprise means for varying the current density of the bias current in dependence upon a surface area of a pixel.
- 10 2. An electroluminescent display device as claimed in claim 1, characterized in that the drive means comprise means for defining the capacitance of a pixel.
3. An electroluminescent display device as claimed in claim 2, characterized in that the means for defining the capacitance of a pixel comprise means for adding an alternating
15 current to the bias current of the pixel and for measuring the associated AC voltage.
4. An electroluminescent display device as claimed in claim 2, characterized in that the means for defining the capacitance of a pixel comprise means for supplying a pixel with a fixed measuring current, and means for fixing the voltage caused by the measuring
20 current across the pixel.
5. An electroluminescent display device as claimed in claim 4, characterized in that the means for supplying a pixel with a fixed measuring current limit the voltage across the pixel within a measuring period to a value below the threshold voltage of the pixel.
25
6. An electroluminescent display device as claimed in claim 2, characterized in that the means for defining the capacitance of a pixel comprise means for applying a voltage pulse across a pixel and for defining the decay time of the current through the pixel.

7. An electroluminescent display device as claimed in claim 6, characterized in that the decay time is compared with the decay time of a reference circuit.
8. An electroluminescent display device as claimed in claim 2, characterized in that the means for defining the capacitance of a pixel comprise means for defining the resonance frequency of a circuit of which the pixel forms part.
9. An electroluminescent display device as claimed in claim 1, characterized in that the electroluminescent display device comprises at least four pixels having a different surface area, and drive unit means for applying a voltage in the reverse direction across the pixels, and means for defining the reverse current.
10. An electroluminescent display device as claimed in claim 9, characterized in that the electroluminescent display device comprises a drive circuit for multiplexing at least two pixels.

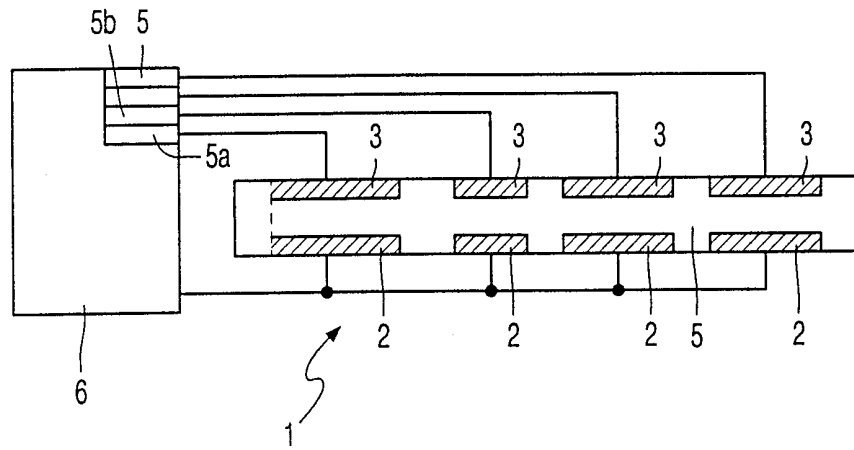

FIG. 1

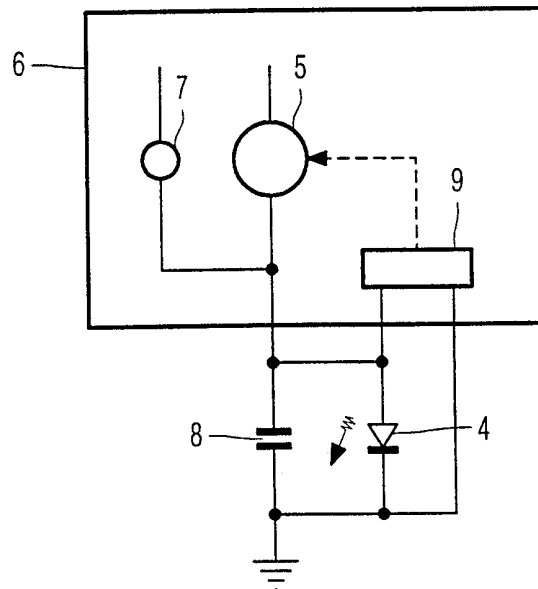

FIG. 2

2/4

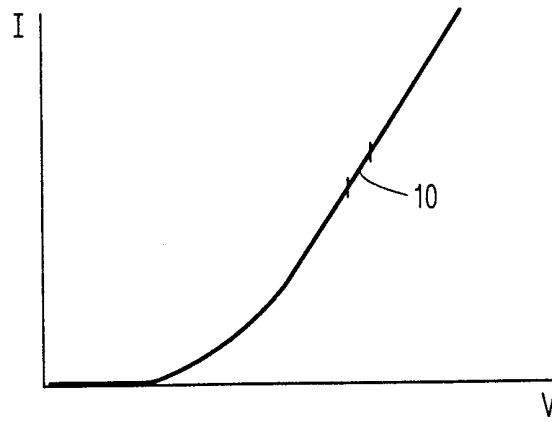

FIG. 3

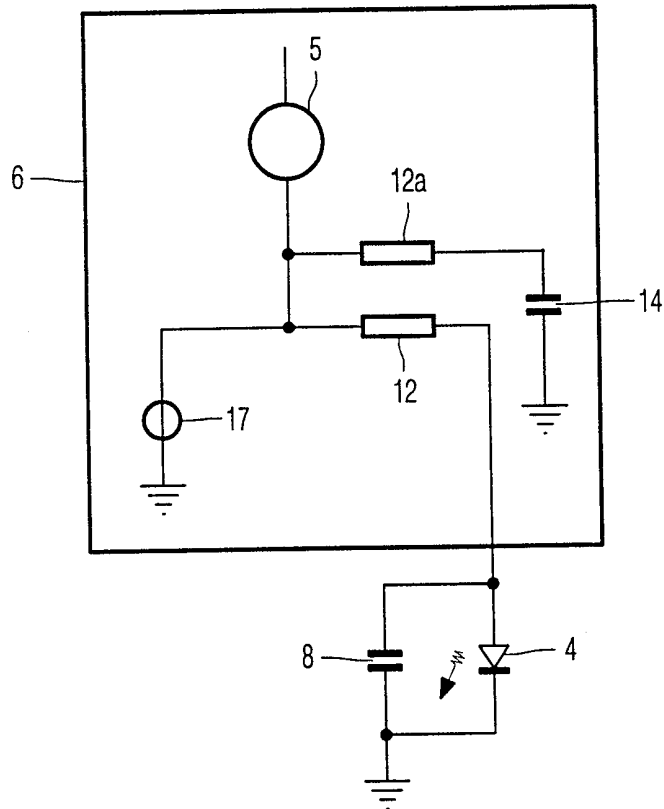

FIG. 4

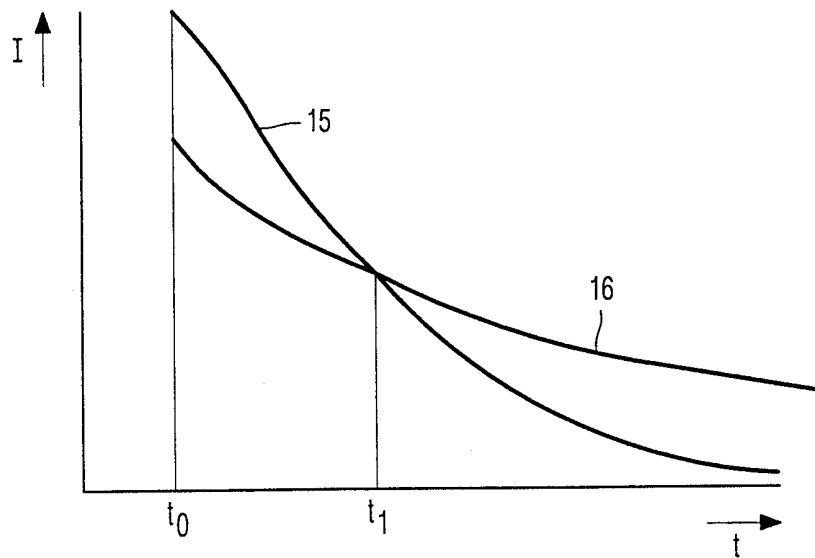

FIG. 5

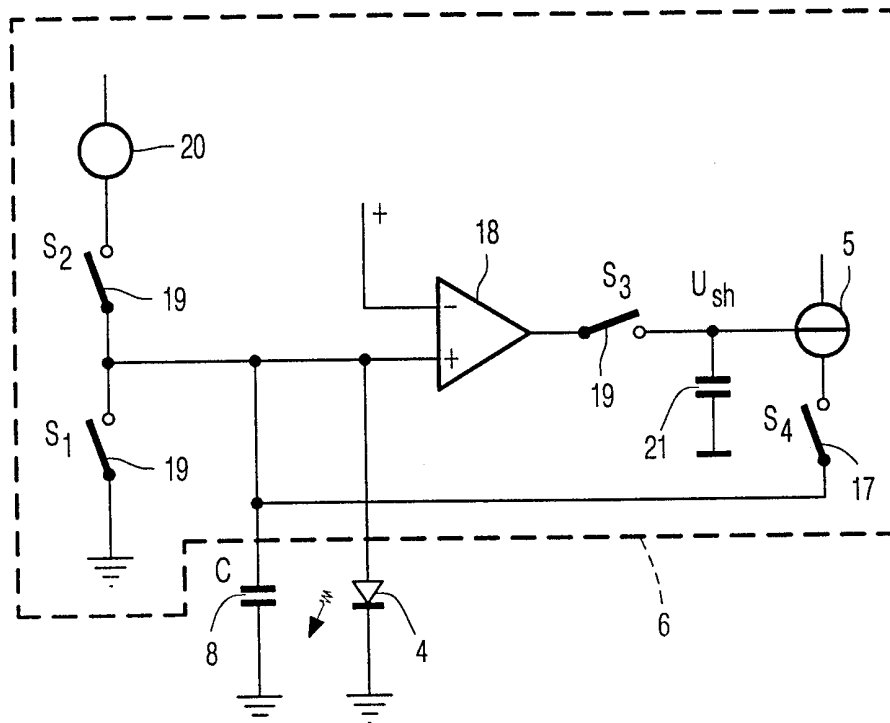

FIG. 6

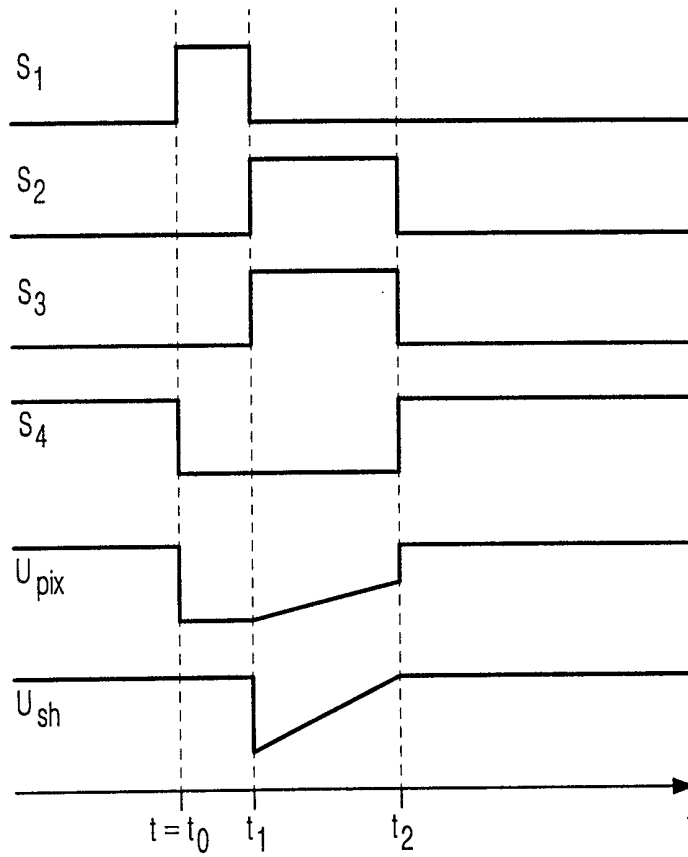

FIG. 7

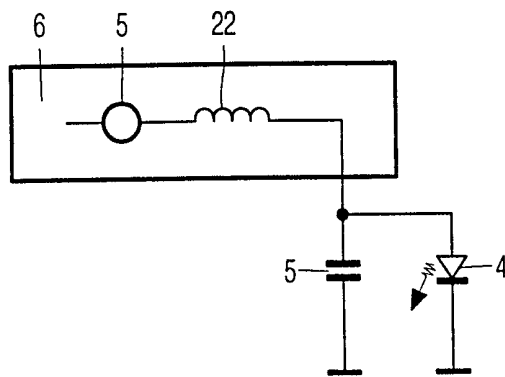

FIG. 8

INTERNATIONAL SEARCH REPORT

International Application No

PCT/EP 99/10404

A. CLASSIFICATION OF SUBJECT MATTER
IPC 7 G09G3/32

According to International Patent Classification (IPC) or to both national classification and IPC

B. FIELDS SEARCHED

Minimum documentation searched (classification system followed by classification symbols)
IPC 7 G09G H05B

Documentation searched other than minimum documentation to the extent that such documents are included in the fields searched

Electronic data base consulted during the international search (name of data base and, where practical, search terms used)

C. DOCUMENTS CONSIDERED TO BE RELEVANT

Category °	Citation of document, with indication, where appropriate, of the relevant passages	Relevant to claim No.
A	PATENT ABSTRACTS OF JAPAN vol. 1999, no. 03, 31 March 1999 (1999-03-31) & JP 10 319910 A (TDK CORP), 4 December 1998 (1998-12-04) abstract ---	1,4
A	US 5 684 368 A (SO FRANKY ET AL) 4 November 1997 (1997-11-04) abstract; figures 3-5 ---	1
A	EP 0 390 407 A (TEKTRONIX INC) 3 October 1990 (1990-10-03) column 2, line 52 -column 3, line 56; figure 2 ---	3,4
	-/--	

Further documents are listed in the continuation of box C.

Patent family members are listed in annex.

° Special categories of cited documents :

- "A" document defining the general state of the art which is not considered to be of particular relevance
- "E" earlier document but published on or after the international filing date
- "L" document which may throw doubts on priority claim(s) or which is cited to establish the publication date of another citation or other special reason (as specified)
- "O" document referring to an oral disclosure, use, exhibition or other means
- "P" document published prior to the international filing date but later than the priority date claimed

- "T" later document published after the international filing date or priority date and not in conflict with the application but cited to understand the principle or theory underlying the invention
- "X" document of particular relevance; the claimed invention cannot be considered novel or cannot be considered to involve an inventive step when the document is taken alone
- "Y" document of particular relevance; the claimed invention cannot be considered to involve an inventive step when the document is combined with one or more other such documents, such combination being obvious to a person skilled in the art.
- "&" document member of the same patent family

Date of the actual completion of the international search

15 June 2000

Date of mailing of the international search report

23/06/2000

Name and mailing address of the ISA

European Patent Office, P.B. 5818 Patentlaan 2
NL - 2280 HV Rijswijk
Tel. (+31-70) 340-2040, Tx. 31 651 epo nl,
Fax: (+31-70) 340-3016

Authorized officer

Van Roost, L

INTERNATIONAL SEARCH REPORT

International Application No

PCT/EP 99/10404

C.(Continuation) DOCUMENTS CONSIDERED TO BE RELEVANT		
Category °	Citation of document, with indication, where appropriate, of the relevant passages	Relevant to claim No.
A, P	WO 99 40559 A (KONINKL PHILIPS ELECTRONICS NV ;PHILIPS AB (SE)) 12 August 1999 (1999-08-12) claims 1,2 -----	1,9

INTERNATIONAL SEARCH REPORT

Information on patent family members

International Application No

PCT/EP 99/10404

Patent document cited in search report	Publication date	Patent family member(s)	Publication date
JP 10319910 A	04-12-1998	NONE	
US 5684368 A	04-11-1997	EP 0813180 A JP 10063228 A	17-12-1997 06-03-1998
EP 0390407 A	03-10-1990	US 4952820 A JP 2106146 C JP 2281667 A JP 8008377 B	28-08-1990 06-11-1996 19-11-1990 29-01-1996
WO 9940559 A	12-08-1999	EP 0974140 A	26-01-2000