

FOR THE PURPOSES OF INFORMATION ONLY

Codes used to identify States party to the PCT on the front pages of pamphlets publishing international applications under the PCT.

AT	Austria	ES	Spain	MG	Madagascar
AU	Australia	FI	Finland	ML	Mali
BB	Barbados	FR	France	MN	Mongolia
BE	Belgium	GA	Gabon	MR	Mauritania
BF	Burkina Faso	GB	United Kingdom	MW	Malawi
BG	Bulgaria	GN	Guinea	NL	Netherlands
BJ	Benin	GR	Greece	NO	Norway
BR	Brazil	HU	Hungary	PL	Poland
CA	Canada	IT	Italy	RO	Romania
CF	Central African Republic	JP	Japan	SD	Sudan
CG	Congo	KP	Democratic People's Republic of Korea	SE	Sweden
CH	Switzerland	KR	Republic of Korea	SN	Senegal
CI	Côte d'Ivoire	LI	Liechtenstein	SU ⁺	Soviet Union
CM	Cameroon	LK	Sri Lanka	TD	Chad
CS	Czechoslovakia	LU	Luxembourg	TG	Togo
DE*	Germany	MC	Monaco	US	United States of America
DK	Denmark				

+ Any designation of "SU" has effect in the Russian Federation. It is not yet known whether any such designation has effect in other States of the former Soviet Union.

Electrode, provided with a polymer coating with a redox enzyme bound thereto.

5 The invention relates to an electrode which is provided with a polymer coating having a redox enzyme bound thereto and which electrode, depending on the chosen aim, can be used either in a biosensor for the specific detection of certain substances recognisable to the particular enzyme or in the production of chemicals which can be prepared by the particular enzyme. The
10 invention also relates to biosensors and production installations for chemicals, which contain such an electrode.

A biosensor of the type described above is disclosed in Anal. Chem. 1990, 62, pp. 1111-1117. More particularly, this literature reference relates to a platinum-plated carbon electrode, which is
15 provided with the redox enzyme glucose oxidase and a layer of polymerised 1,2-diaminobenzene applied by means of electropolymerisation. Using a glucose sensor of this type, based on flavin adenine dinucleotide (FAD) - bound glucose oxidase (GOd), the glucose to be detected is determined indirectly with the aid of the
20 liberated hydrogen peroxide, as is illustrated by the reaction equations given below:

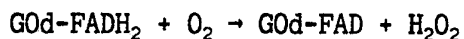
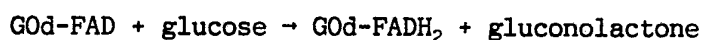

25 However, the detection of this hydrogen peroxide, which is detected at the anode, has the disadvantage that said detection must be carried out under high voltages applied to the sensor, which can give rise to interference by other substances. Moreover, the hydrogen peroxide has a degrading action on the glucose oxidase used as redox enzyme (see p. 1112, left hand column, paragraph three). In
30 addition, it is pointed out that an immobilisation of the glucose oxidase preferably takes place using a carbodiimide as agent providing covalent bonds and/or glutaraldehyde as crosslinking agent, which makes the production of such a biosensor fairly laborious.

35 In Acc. Chem. Res. 23 (1990), pp. 128-134 the use of small diffusing mediators such as, for example, ferrocene and ferrocene derivatives, as synthetic electron acceptor for redox enzymes is

reported. In the case of glucose oxidase, the glucose to be detected is determined indirectly via the (reduced) mediator; see the reaction equations below:

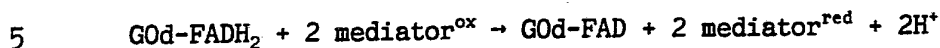
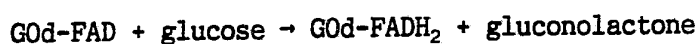

The reduced mediator obtained is then oxidised electrochemically. However, it has been found that the use of a mediator is associated with disadvantages such as the leakage of the mediator from the system. Moreover, suitable mediators often have toxic characteristics. This severely restricts the field of application of sensors based thereon.

10

Sensors and Actuators B1 (1990), pp. 537-541 discloses the use of a polypyrrole film applied to an electrode surface, which film is bonded covalently, via a carbodiimide activation, with redox enzymes such as glucose oxidase and the like. Biosensors having a relatively short response time are obtained in this way. However, in the production of such biosensors a carbodiimide is required as reagent, the use of which is found to be undesirable.

15

Biotechnol. Bioeng. (1988), 31, 6, 3/2, 553-558 discloses an electrocatalysis reactor in which glucose oxidase is used as redox enzyme. This glucose oxidase is applied to the surface of carbon felt by means of carrying out an interface oxidation of the carbon in order to form carboxylic acid groups and an activation of these groups by means of a carbodiimide, followed by immobilisation of the glucose oxidase. A solution of glucose (as starting material for gluconic acid) and benzoquinone (as electron transfer mediator) was passed through the reactor described in this literature reference. The reactor produces gluconic acid from glucose at a rate of about 100 g/hour.litre of reactor. Apart from the specific method of immobilisation of the redox enzyme, the use of the mediator is also found to be not very suitable.

20

25

30

US-A- 4,582,575 relates to electrically conductive composites comprising a dielectric porous substance e.g. fiberglass fabric, and the electrically conducting polymer polypyrrole deposited in the pores and interstices of such substance. Such type of composites which pores and interstices have been impregnated i.e. practically filled with polypyrrole do have - considering the high brittleness

35

of polypyrrole per se - both a good electrical conductivity and good mechanical properties i.e. are essentially non-brittle and readily handleable.

5 From Analytical Chemistry, Vol. 58, 1966, pages 2979-2983 it is known to immobilize the enzyme glucose oxidase in an electrically conducting polypyrrole matrix by electropolymerizing pyrrole in aqueous media containing glucose oxidase. As appears from page 2982, second paragraph of this reference a simple absorption of glucose oxidase by exposing a preformed polypyrrole film to a glucose
10 oxidase solution is not considered possible as such a treated polypyrrole film present in an oxygen-saturated solution containing glucose, KI, Mo(VI) and buffer does not yield current or iodine formation.

The aim of the invention is to develop an electrode of the
15 type formulated in the preamble, which electrode can be produced in a simple manner and has extensive application possibilities, such as, for example, in a biosensor or in a production installation for the preparation of specific chemicals. A production installation of this type has not yet been described in the literature.

20 It has been found that the abovementioned aim can be achieved with the aid of an electrode which is composed of a membrane, provided with open pores running through said membrane, the walls of the pores having an electrically conducting polymer coating, which polymer coating present on the wall of the open pores contains a
25 redox enzyme bound thereto. Preferably one side of the membrane is provided with a conducting layer consisting of for instance a metal or carbon, which layer is in contact with the polymer coating.

In general the direct electron transfer between the redox
30 enzyme e.g. glucose oxidase and the conducting polymer occurring in the electrodes according to the invention is illustrated in Fig. 1.

More particularly, within the framework of the invention it can be stated that the Applicant has made use of, on the one hand, the mesoscopic space of the pore and/or interstices containing
35 membranes and, on the other hand, of the morphology of the electrically conducting polymer, by which means it has proved possible to establish an electron transfer, proceeding via the polymer, between the redox enzyme, such as, for example, glucose

oxidase, and the electrode and also to incorporate the redox enzyme in the pores while maintaining the activity of said enzyme. It is pointed out that a significant advantage of the subject of the invention is that in this case no auxiliaries known from the prior art, such as carbodiimides, glutaraldehyde and the like, are needed for immobilisation of the redox enzyme.

With regard to the electrode according to the invention it is also pointed out that the redox enzymes present in the pores of the membrane, on the one hand, have a better opportunity for retaining their tertiary structure and, on the other hand, in the pores of the membrane are better screened against external influences, such as shear forces exerted thereon and the influences arising when handling the sensor.

With regard to the electrode according to the invention, the membranes used can be many commercially available inert membranes, such as the commercial products Nuclepore membranes, Cyclopore membranes, Anopore membranes and Millipore membranes. More particularly, Nuclepore membranes are, for example, polycarbonate or polyester membranes, which membranes are provided with uniform cylindrical pores which pass through the membrane. Like the organic Nuclepore membranes, the organic Cyclopore membranes and the inorganic Anopore membranes also possess pores passing through the membrane. With regard to the thickness of the membranes, it can be stated that this is not critical per se and is usually in the range of 1-20 μm and advantageously about 10 μm . The diameter of the pores present in the membranes can vary within wide limits and is usually in the range of 100-10,000 nm (0.1-10 μm), advantageously in the range of 100-1000 nm. The pore density (number of pores/ cm^2) is partly dependent on the pore diameter, but is usually in the range of 10^5 - 3×10^8 .

Another type of membranes can be manufactured on the basis of latex particles to create porous layers in which polypyrrole can be electrochemically synthesized. Within the interspherical pores of the polypyrrole modified latex layers a redox enzyme like glucose oxidase can be adsorbed irreversibly while its catalytic activity is retained. The latex particles - applicable according to the invention - have a diameter in the range of 50-1000 nm, preferably

50-300 nm. Examples of suitable latex materials are a.o. (monodispers) polystyrene latex, polymethyl methacrylate latex, a silica latex or a latex of a conducting polymer like polypyrrole and polyacetylene. Specific latex examples are Unisphere latex particles having a diameter of 50 nm (type 10) or 100 nm (type 11) (Brunschwig Chemie B.V., the Netherlands) and "Polybead" polystyrene microspheres having a diameter of 50, 100 and 200 nm respectively (Polysciences Corp. Niles/Ill., USA).

In principle, the electrically conducting polymers used can be the polymers known from the prior art, such as the polymers which are based on pyrrole, substituted pyrrole derivatives, thiophene, substituted thiophene derivatives, aniline and substituted aniline derivatives. Preferably, pyrrole is used as the monomer for the production of an electrically conducting polypyrrole coating. The thickness of the layer applied in the pores partly depends on the diameter of the pores in the membrane, as said pores must still be open following the application of the polymer coating. Usually, polypyrrole coatings having a thickness of 50-200 nm are used, but coatings having a thickness deviating therefrom can also be used.

Diverse types of redox enzymes, for instance oxidases and dehydrogenases, may be mentioned as redox enzymes to be applied in the coated pores of the membrane. Examples of such enzymes are glucose oxidase, lactose oxidase, galactose oxidase, enoate reductase, hydrogenase and choline dehydrogenase. Glucose oxidase is advantageously used. This redox enzyme is usually present in an amount of 0.02-0.2 U/cm² of membrane surface. (1 U (unit) oxidises 1 µmol of β-D-glucose to D-gluconic acid and H₂O₂ per minute at pH=5.1 and a temperature of 35°C). With the aid of redox enzymes of this type, the relevant substances can be either specifically detected (biosensor) or specifically converted to give the relevant reaction products (bio-electrochemical production installation). An example which may be mentioned is β-D-glucose oxidase (E.C. 1.1.3.4 from Aspergillus niger), with which, on the one hand, glucose can be detected in a specific manner and, on the other hand, β-D-glucose can be converted to D-gluconic acid in a specific manner.

The electrode according to the invention may be provided on at least one side with a conducting layer consisting of for instance

a metal or carbon, which layer can connect the electrode to the measuring instrument coupled thereto. Examples of suitable metals for this purpose are, inter alia, platinum, gold and palladium, platinum being preferred. The application of the metal layer can be carried out in a known manner, such as, for example, by means of sputtering, vapour deposition and the like. The thickness of such a metal layer is usually 100-500 nm.

Within the framework of the invention, the electrodes can be produced as follows. The membranes used can be, for example, Nuclepore membranes containing pores having, for example, a diameter of 100-10,000 nm, advantageously 200-8000 nm and preferably 800-1000 nm. The electrically conducting polymer coating can be applied to the pores of the membrane with the aid of an oxidising chemical polymerisation. For this purpose, for example, a pyrrole solution in water (for example 0.3-0.8 M pyrrole) and an iron(III) chloride solution in water (1.5-2.5 M) are allowed to come into contact with one another, one reagent being placed on one side of the membrane and the other reagent on the other side of the membrane. The pyrrole monomers and the oxidising iron(III) chloride solution meet one another in the pores of the membrane, which results in a polymerisation of the pyrrole. The polymerisation time is not critical and can be, for example, 2-10 min. In this context it is pointed out that the porosity is the main parameter. The polymerisation reaction can be stopped, for example, by rinsing with water or a phosphate buffer solution (PBS: pH = 6.5). A polymerisation time appreciably longer than 10 min. leads to non-porous membranes, which are not usable within the framework of the invention. A scanning electron micrograph of a track-etch Cyclopore membrane which pores are coated with the conducting polymer polypyrrole is shown in Fig. 2a.

After applying the electrically conducting polymer coating to the walls of the pores of the membrane and, when necessary, removing any polymer coating on the side(s) of the membrane by, for example, wiping off, a metal layer of platinum or a similar metal may be applied to one side of the membrane by means of, for example, sputtering using an Edwards Sputtercoater S150B.

Finally, the membrane is provided in the pores, the walls of

which are coated with an electrically conducting polymer, which a redox enzyme such as glucose oxidase by treating the membrane with a redox enzyme-containing solution, with stirring, at a temperature of, for example, 2-10°C, advantageously 4°C, for at least 0.1 hour, preferably at least 0.5 hour. The concentration of glucose oxidase in the solution can vary within wide limits and is about 5 mg/ml. Following this treatment, the prepared membranes can be dried overnight in a desiccator over CaCl₂.

According to another embodiment of the invention latex membranes may be manufactured by casting latex particles on a freshly sputtered metal (e.g. platinum) surface from an aqueous solution, containing the suspended latex particles and - if desired - agarose. Agarose may be added for better attachment of the latex spheres to each other and to the electrode. Subsequently the latex droplet is dried at low temperature to get a uniform layer without cracks in the surface. After drying, the latex modified electrodes are heat-treated resulting in a membrane consisting of a very strong layer of uniform latex particles.

The amount of agarose present in the latex suspension may be varied to minimize the amount of agarose necessary to yield good latex layers. For instance latex layers were cast from solutions containing 0.125, 0.100, 0.075, and 0.050 wt% agarose respectively. The agarose content of 0.125 % led to latex layers which were less accessible for polypyrrole coating. Biosensors constructed from latex layers containing this amount of agarose displayed lower activity and very long response times (vide infra). Lower amounts than 0.125 wt% of agarose resulted in strong latex layers which could successfully be treated with polypyrrole. The lowest agarose content tested (0.050 wt%) still yielded strong adhering latex layers. Therefore, in the further synthesis of latex layers, latex suspensions with 0.05 wt% agarose were used.

As indicated in Example 2 below thick layers (ca. 5 µm) as well as thin layers (ca. 1 µm) were made. This was accomplished by using two different latex concentrations in the droplet that was cast on the electrode. The droplet size was kept constant. In both cases strong and smooth layers were obtained. Uniform spheres of two different dimensions were used to make latex membranes. Both

particle sizes (112 and 220 nm diameter respectively) yielded layers with interspherical pores in the order of 50-200 nm.

5 The latex layers were modified with polypyrrole by means of electrochemical polymerization. Although polymerization media having a pyrrole concentration of 0.2-0.8 Molar may be used. The polymerization medium was phosphate buffered saline (PBS), containing 0.3 M pyrrole. This medium was chosen because enzyme treatment of the polypyrrole modified latex must preferably be performed in PBS. By using the same medium during polymerization and 10 enzyme treatment it was avoided that exchange of dopant ions in the polymer with the solution could take place. When this would happen, major changes in the conducting polymer properties could occur. The electrochemical polymerization was galvanostatically controlled. In this way Applicant was able to vary the amount of polypyrrole in the latex layers by changing the polymerization time. It was found that 15 galvanostatic polymerization gave much more reproducible results than polymerization under potentiostatic control. Potentiostatic control resulted in non-uniform coating of the latex layer; large areas on the electrode surface were still white (clean latex) while other areas showed spots of very high polypyrrole content. Galvanostatic polymerization at moderate current densities (20 mA/cm²) resulted in an evenly spreaded polypyrrole coating of the latex. 20

25 The amount of charge (current*time) in the polymerization reaction was varied from 100 to 1000 mC/cm². The blackening of the originally white latex layers was proportional to the amount of charge passed. Although only qualitatively, this was a good indication of the proper galvanostatic polymerization of pyrrole in the matrix of latex particles.

30 Scanning electron microscopy (SEM) was used to image the coated latex layers. The images show how the membrane structure changes with polymerisation time (Fig. 2b-d). In Figure 2b a very open structure is visible between the spheres that make up the bare latex layer. In Figure 2c, the latex particles are coated with a thin layer of polypyrrole (amount of charge passed is 300 mC/cm²). 35 The porous structure is still present, while the internal surface now consists largely of polypyrrole. For reference, two uncoated

latex spheres are visible at the surface. When the latex layer becomes coated with large amounts of polypyrrole, the porosity of the composite layer is lost (Figure 2d). Shown in Figure 2d is a thick latex layer, treated for 75 s. (1500 mC/cm^2). No enzyme electrodes could be made with these nonporous latices.

LEGEND

Fig. 1: Electron shuttle showing the path of the electrons involved in the enzymatic glucose oxidation.

Fig. 2: Scanning electron micrographs of a track-etch Cyclopore membrane coated with a conducting polymer (= polypyrrole); small hollow channels are formed during the polymerization process (a) and of $0.22 \mu\text{m}$ latex particles on a platinum electrode; (b) untreated layer, (c) layer treated with polypyrrole for 15 seconds, (d) layer treated with polypyrrole for 75 seconds.

Fig. 3: Set-up for carrying out the pyrrole polymerisation in the pores of a membrane:

- (1) injection syringe;
- (2) plunger of the injection syringe;
- (3) FeCl_3 solution;
- (4) holder for the membrane;
- (5) membrane;
- (6) pyrrole solution;
- (7) rubber ring.

Fig. 4: Plot of GOd activity of polypyrrole-modified Nuclepore membrane, the polypyrrole being provided with glucose oxidase. In this figure the time in minutes is plotted on the X axis and the current strength in microamperes on the Y axis.

The numerals 1 to 5 indicate the following points:

- (1): introduction of the polypyrrole-modified Nuclepore

membrane (pore diameter: 800 nm; porosity: 3×10^7 pores/cm²; material: polyester) obtained in accordance with the example below, the polypyrrole being provided with glucose oxidase, into an electrochemical cell, as described below for the test for determination of the enzyme activity;

- (2): removal of the membrane from the electrochemical cell;
- (3): introduction of the membrane into the electrochemical cell;
- (4): removal of the membrane from the electrochemical cell;
- (5): introduction of a solution which contains 0.02 U GOD in order to calibrate the measurement.

5

10

15

Fig. 5: Plot of the amperometric response with respect to glucose of a sensor membrane under an argon atmosphere. In the figure the time in minutes is plotted on the X axis and the current strength in microamperes on the Y axis.

20

Fig. 6: Plot of the calibration curve for glucose. In this figure the glucose concentration in mM is plotted on the X axis and the current strength in microamperes on the Y axis. The curve shows the response under argon following injection of 15 μ l, 30 μ l, 45 μ l, 75 μ l, 150 μ l, 225 μ l, 300 μ l and 375 μ l of glucose (1 M) in 15 ml of PBS buffer (pH = 7.0; phosphate concentration: 10 mM).

25

30

Fig. 7: Rotating disk electrode assay of glucose oxidase immobilized on 0.112 μ m latex particles. (1) & (3): introduction of latex membrane electrode; (2) & (4): withdrawal of latex membrane electrode; (5): introduction of 0.125 U GOD.

35

Fig. 8: Set up for continuous flow measurements of latex membrane biosensors. (a) carrier solution (PBS); (b) sample solution (glucose); (c) peristaltic pump; (d) flow cell;

(e) waste; (f) potentiostat; (g) computer; (h) recorder.

- 5
Fig. 9: Current response of thin latex layers (ca. 1 μm). Latex particle size 0.22 μm . Measured at 0.35 V vs. Ag/AgCl under argon atmosphere with 25 U/ml catalase. Membranes treated with various amounts of pyrrole polymerization charge. (+) 300 mC/cm^2 ; (o) 400 mC/cm^2 .
- 10
Fig.10: Calibration curves for two latex glucose sensors, made under the same experimental conditions. Latex layer (ca. 1 μm) consisting of 0.22 μm particles. Measured at 0.35 V vs. Ag/AgCl under argon atmosphere with 25 U/ml catalase. Membranes treated with 150 mC/cm^2 of pyrrole polymerization charge.
- 15
Fig.11: Current response of thick latex layers (ca. 5 μm). Measured at 0.35 V vs. Ag/AgCl under argon atmosphere with 25 U/ml catalase. Membranes of 112 and 220 nm particles, treated with various amounts of pyrrole polymerization charge.
- 20
(a) 112 nm: (+) 200 mC/cm^2 , (\blacktriangle) 400 mC/cm^2 ;
(b) 220 nm: (+) 200 mC/cm^2 , (\blacktriangle) 400 mC/cm^2 ,
(o) 500 mC/cm^2 .
- 25
Fig.12: Calibration curves for optimized latex-polypyrrole sensors. Measured at 0.35 V vs. Ag/AgCl under argon atmosphere with 25 U/ml catalase.
- 30
(a) Thin layer of 220 nm latex particles, charge 150 mC/cm^2 ;
(b) Thick layer of latex: (+) 112 nm latex, charge 200 mC/cm^2 ; (\blacktriangle) 220 nm latex, charge 400 mC/cm^2 .
- 35
Fig.13: Stability of latex-polypyrrole biosensor at continuous operation under ambient atmosphere in the presence of 1 mM glucose. The activity was measured daily by introducing an additional amount of glucose up to a concentration of 5 mM.

Fig.14: Current response of a latex-polypyrrole biosensor upon the addition of glucose. Measurement at 0.35 V vs. Ag/AgCl. Dashed line: in air saturated solution under ambient atmosphere; solid line: in argon flushed solution under argon atmosphere with 25 U/ml catalase.

Fig.15: Current response versus time of a latex membrane consisting of 220 nm particles with 100 mC polypyrrole. Measuring potential 0.10 V vs. Ag/AgCl.
(a) 10 mM glucose under ambient atmosphere;
(b) 0.0025 % hydrogen peroxide.

EXAMPLE I

A) Production of an electrode according to the invention.

(1) Reagents used.

Glucose oxidase (E.C. 1.1.3.4) from Aspergillus niger, type II (25,000 U/g), and catalase (E.C. 1.11.1.6) from bovine liver, 2800 U/mg were obtained from Sigma.

Benzoquinone was obtained from Aldrich (France) and was sublimed before use. Pyrrole was obtained from Merck and anhydrous iron(III) chloride (98%) was obtained from Fluka and these compounds were used in the form supplied. The Nuclepore membranes were obtained from Ankersmit (The Netherlands). All other reagents used were of p.a. grade (analytical grade).

(2) Oxidising chemical polymerisation of pyrrole in the Nuclepore membranes.

The polymerisation of pyrrole in the pores of the filtration membranes of the Nuclepore type was achieved by allowing an aqueous 2 M FeCl₃ solution (amount usually used: 4 ml) and an aqueous 0.6 M pyrrole solution (amount usually used: 1 ml) to precipitate in a membrane (diameter: 25 mm). In practice, this was carried out by positioning an injection syringe, which was filled with the iron chloride solution, vertically and mounting a

standard membrane holder on the syringe (see Fig. 3). The level of oxidising iron(III) chloride solution in the membrane holder was raised until the solution just touched the membrane resting on the said holder. The membrane was weighted down with a rubber ring. 1 ml of the abovementioned pyrrole solution was then applied to the membrane. The polymerisation time was measured from the time this solution was applied. For Nuclepore membranes containing pores having a diameter of 0.8 μm (pore density: 3×10^7 pores/ cm^2) and containing pores having a diameter of 1 μm (pore density: 2×10^7 pores/ cm^2) the polymerisation was continued for 1-10 min., after which time the membrane was removed and rinsed with excess water or a phosphate buffer (PBS); pH = 6.5.

(3) Coating of one side of the Nuclepore/pyrrole membrane according to (2) with platinum.

Using a template with an opening which was just a little smaller than the diameter of the membrane concerned, a polypyrrole-modified filter membrane was pressed against the cooling plate of an Edwards S150B sputtercoater. 100-400 nm of Pt were then applied by sputtering under an argon pressure of 8 mBar and using a sputtering current of 50 mA. The layer thickness was measured using an Edwards FTM5 unit.

(4) Immobilisation of glucose oxidase in the modified filter membranes according to (3).

For enzyme immobilisation, the membranes which were obtained in accordance with (3) and had an original pore diameter of 800 and 1000 nm were used. For immobilisation, a membrane was introduced into 4 ml of a 5 mg/ml GOD solution, after which the whole was shaken with the aid of a Gyrotory Shaker Model G2 (New Brunswick Scientific, USA). The immobilisation took place at 4°C over a minimum of half an hour. The membrane was then rinsed in PBS (pH = 6.5) and dried overnight at 4°C. This drying took

place in a desiccator under normal pressure and in the presence of CaCl_2 .

5 B) Testing of the electrode according to the invention obtained under (A).

Test methods

10 (1) The enzyme activity was determined with the aid of the three-electrode cell which contained 15 ml of 0.1 M phosphate buffer (pH = 6.5), 5 mM benzoquinone and 0.5 M glucose. The glucose solution was allowed to mutarotate for at least 24 hours. The test was carried out using a Pt rotary disc electrode (RDE), which was provided with an
15 Electrocraft Corporation Model E550 motor and an E552 speed control unit. A potential of 0.350 V (Ag/Ag^+ reference) was applied to the Pt working electrode and the latter was rotated at a speed of 3000 revolutions per
20 minute. A spiral-shaped Pt electrode was used as auxiliary electrode. the solution was flushed with argon before each test. During the test the solution was blanketed with argon.

25 All electrochemical measurements were carried out using an Autolab potentiostat which was controlled by means of an Olivetti M24 personal computer and General Purpose Electrochemical System (GPES) software (Eco Chemie, The Netherlands). The current output was recorded using a
30 Yew 3056 pen recorder. The actual test was carried out by recording the current output of the RDE on submerging the sample membrane in the abovementioned solution.

35 (2) Amperometric measurements on membrane sensors according to the invention were carried out in a three-electrode cell using the sensor as working electrode. In this case the membrane was clamped between a folded Pt strip, which strip was electrically connected to a potentiostat. In

order to obtain a rigid electrode, the membrane was joined to a glass plate with the aid of double-sided adhesive tape.

5 A potential of 0.175 V against Ag reference was applied to the sensor. A spiral-shaped Pt wire was used as auxiliary electrode. The cell contained 15 ml of 0.1 M phosphate buffer (pH = 6.5) containing 10 U/ml catalase and was kept under an argon atmosphere. Stirring was carried out with
10 the aid of a magnetic rod stirrer. Following an initial current strength this fell to a steady state value, after which samples of 1 M glucose solution were added; the resulting current response was recorded.

15 C) Results

(1) The enzyme activity was determined with the aid of the above method. When carrying out the test, the natural co-substrate (oxygen) was replaced by the synthetic electron acceptor benzoquinone. The hydroquinone, which was formed
20 during the catalytic cycle, was measured electrochemically using the rotary disc electrode (RDE). The regeneration of the benzoquinone from hydroquinone starts at the RDE at a certain potential (0.35 V against Ag) and the resulting current is a measure for the enzyme activity. Although a
25 slight increase in current strength arises as a consequence of the non-catalysed oxidation of glucose by benzoquinone, the current strength as a consequence of the catalytic action of the enzyme is sufficiently large to give an appreciable difference in the gradient of the
30 current/time curve (see Fig. 4). Fig. 4 shows the effect on the measured current when the membrane according to the invention (see above) is introduced into the electro-chemical cell. As can be seen from Fig. 4, the current increases immediately following the introduction of the
35 membrane. This effect occurs in the case of the Nuclepore membranes having initial pore diameters of 800 nm and 1000 nm, which have been indicated above.

The fact that the activity returns to the initial value following removal of the membrane according to the invention is evidence of suitable immobilisation of the enzyme. Material which is not correctly immobilised will remain in the solution and have the consequence that the gradient of the line after point 2 in Fig. 4 would be higher. This has in fact also been found in the case of membrane which were treated with a GOd solution but did not have a polypyrrole coating in the pores of the membrane. Since no polypyrrole is present on the surface of the membrane (see the experimental section), it is assumed that no enzyme is absorbed on this surface. Fig. 4 shows that the successive introduction and removal of the membrane has no influence on the amount of actively immobilised enzyme. This is also the case if a membrane is measured which has been stored for two weeks at 4°C. No significant decrease in the enzyme activity can be detected. At the end of each measurement, a known amount (5 µg = 0.1 U) of enzyme is added in order to calibrate the activity (point 5 in Fig. 4). Assuming that the electrochemical reaction is a rapid process, the diffusion of hydroquinone to the electrode will be the rate-determining step. Therefore, it is of little or no significance for the measurement where the hydroquinone is formed. This signifies that the gradients resulting from immobilised and free enzyme can be correlated, at least in a semi-qualitative manner. It can be concluded from the calibration that about 0.02 U/cm² of active GOd is present in the membrane.

- (2) Fig. 5 shows the electrochemical response of the system with respect to the addition of glucose. In this example, as indicated above, the membrane was used as working electrode. A potential of 0.175 V against Ag was applied to the membrane. A platinum wire served as auxiliary electrode. The amperometric response was determined in a stirred cell, which was filled with 15 ml of 0.1 M phos-

phate buffer. The Nuclepore membranes containing pores having a diameter of 800 and 1000 nm, which have been described above, were tested in this way. The increase in current strength (Fig. 5) was determined under an argon atmosphere and in the presence of 10 U/ml catalase. The latter enzyme was added for the decomposition of any H₂O₂ which may be produced enzymatically to accidental oxygen mediation. The potential applied was, as stated, 0.175 V against Ag reference, which is too low a potential to oxidise H₂O₂. Therefore, it can be stated that the enzyme transports its electrons directly to the conducting polymer. The delimited space in the pores of the membrane, together with the amorphous structure of the polypyrrole, apparently brings the active centres of the enzyme molecules into close contact with the conducting polymer.

The response time is less than one minute, which can be regarded as rapid taking into account the geometry of the sensor. The time which is needed to obtain a uniform glucose concentration throughout the entire solution must also be taken into account here; this time can be 10 seconds or more.

The injection of large amounts of glucose gives rise to a saturation effect, so that the current response is not linear with the glucose concentration. This became clear when a calibration curve was made by the successive addition of specific amounts of glucose to the same solution in the cell (Fig. 6). Measurements carried out under argon in the presence of catalase in the solution gave good results up to a concentration of 25 mM glucose.

(3) Competition between the conducting polymer and oxygen.

When oxygen is present, it becomes a competing substrate for the polypyrrole in respect of the acceptance of electrons from the flavin units of GOD. In this case, not only does the current become smaller because of the direct

electron transfer to the polymer but hydrogen peroxide is also formed. Apart from the fact that hydrogen peroxide degrades the enzyme and the conducting polymer, this compound also contributes to the measured signal. Despite the low potential applied to the working electrode (0.175 V/Ag), the latter still reacts to hydrogen peroxide. However, in the presence of catalase, the H_2O_2 formed is effectively destroyed and the measurement is not disturbed.

In order to obtain some insight into the effects of catalase and the presence of an inert atmosphere, measurements were carried out under various test conditions. The results are given in Table A below.

TABLE A

Response for glucose under various test conditions

<u>Test conditions</u>	<u>Response [μA]</u>
Air/PBS buffer only	95
Air/20 U catalase	85
Air/180 U catalase	85
Argon/180 U catalase	85

(The response relates to 75 μl of glucose (1 M) injected into a 15 ml PBS solution (pH = 6.5)).

It can be seen from the results given in Table A that a small amount of catalase already suppresses the interference of oxygen, while argon had no additional effect.

(4) Selectivity

The selectivity of the sensor according to the invention was tested for fructose. No response for fructose was detected.

EXAMPLE IIA) Production of an electrode according to the invention.(1) Materials and apparatus.

5 Glucose oxidase (E.C. 1.1.3.4) type II (25,000 U/g) from
Aspergillus niger and catalase (E.C. 1.11.1.6, 2800
U/mg) from Bovine liver were obtained from Sigma.
Benzoquinone was from Aldrich (FRG) and was sublimed prior
to use. Pyrrole was from Merck and was distilled before
use. Latex suspensions with particles of 112 and 220 nm
10 were from Perstorp analytical. Agarose type VII was
purchased from Sigma. All other reagents were of
analytical grade.

The used galvanostat was constructed at the University of
15 Nijmegen, The Netherlands. The current output of the
galvanostat was monitored with a Fluke 45 digital
multimeter. All electrochemical measurements were
performed with an Autolab potentiostat controlled by an
Olivetti M24 Personal Computer and General Purpose
20 Electrochemical System (GPES)-software (Eco Chemie,
Utrecht, The Netherlands). Current output was recorded on
a Yew 3056 pen recorder. Electron micrographs were made on
a CAMSCAN scanning electron microscope (Cambridge
Instruments).

25

(2) Coating with a metal layer.

Glassy carbon disks of 8 mm diameter (Antec, Leiden, The
Netherlands) were used as the base electrode. The
electrodes were polished with Alpha Micropolish Alumina
30 No. 1C (1.0 micron, Buehler LTD., U.S.A.). Platinum was
applied on the polished surface with an Edwards
sputtercoater S150B. A platinum target of 8 cm diameter
and 0.5 mm thickness was used as the platinum source. The
layer thickness was monitored with an Edwards FTM5 unit.
35 Sputtering was continued until the thickness of the
platinum layers was 300 nm.

(3) Preparation of latex layers.

Agarose type VII was dissolved by boiling an appropriate amount (0.1 or 0.25 wt%) for 2 minutes in distilled water. Freshly made solutions, which were still hot, were used to make the latex membranes. A volume of agarose solution was mixed thoroughly with an equal volume of latex suspension. A 75 μ l droplet was applied on a freshly sputtered platinum disk. After application, the electrode was put in the refrigerator overnight. The dried latex electrode was put in an oven at 333°K for 1 hour.

(4) Preparation of latex membranes with polypyrrole.

Latex electrodes were sealed with teflon tape in such a way as to leave only the latex surface for making contact with the polymerization medium. An aqueous solution containing 0.9 % potassium chloride and 10 mM phosphate (PBS), together with 0.3 M pyrrole was used in the polymerization reaction. The latex layer was put in the solution at least one minute before polymerization took place to allow the solution to penetrate the membrane sufficiently. Afterwards, a constant current (20 mA/cm²) was supplied to the cell for an appropriate time (see Table B). A platinum plate acted as counter electrode. When polymerization was finished the electrodes were rinsed with PBS.

(5) Immobilization of the enzyme.

Enzyme immobilization was achieved by agitating (Gyrotory Shaker model G2, New Brunswick Scientific, USA) membranes in 3 mL of 5 mg/mL of GOd at a temperature of 277 K for 4 hours. The membranes were successively dried overnight on CaCl₂ in a desiccator.

B) Testing of the electrode according to the invention obtained under (A).

(1) Enzyme activity assay

Enzyme activity was assayed with a three electrode cell

containing 20 mL phosphate buffered saline (PBS), pH 7.5, 5 mM benzoquinone and 0.5 M glucose. Prior to use, the glucose solution was allowed to mutarotate for at least 24 hours. The assay was performed with a platinum rotating disk electrode (6 mm diameter) equipped with an Electrocraft corporation model E550 motor and E552 speed control unit. The platinum working electrode was set at a potential of 0.350 V (Ag/AgCl reference) and was rotated at a speed of 2000 rpm. A platinum wire was used as auxiliary electrode. The solution was flushed with argon before each experiment. During the assay argon was blanketed over the solution.

The actual assay was performed by monitoring the current output of the RDE while immersing a sample membrane into the solution. The enzymatic activity of the various latex-polyrrole membranes are indicated in Table B.

TABLE B

Charge (mC/cm ²)	1 μm thickness		5 μm thickness	
	112 nm	220 nm	112 nm	220 nm
100	+	+	x	x
150	+	+	x	x
200	+	+	+	+
300	+	+	+	+
400	-	+	+	+
500	-	-	+	+
1000	-	-	-	-

40 + : enzymatically active membranes
 - : non-active membranes
 x : not tested

(2) Amperometric biosensor activity measurements

To perform amperometric measurements, the enzyme membrane was placed as working electrode in a three electrode flow cell (Sparc Holland). To insulate the active surface of the membrane from the auxiliary electrode, it was covered with a teflon spacer of 1 mm thickness. In the spacer a duct of approximately 0.15 cm² was left, allowing the membrane to make contact with the solution. An Ag/AgCl electrode was used as reference electrode. The base of the flow cell acted as auxiliary electrode (glassy carbon). Buffer solution was driven through the cell at a rate of 1.75 ml/minute (Watson Marlowe 101U peristaltic pump). The potential of the membrane was set at 0.350 V. When the background current had been diminished sufficiently, the buffer solution was replaced by the glucose solution and the current response was monitored, see Table C.

TABLE C

Charge (mC/cm ²)	1 μm thickness		5 μm thickness	
	112 nm	220 nm	112 nm	220 nm
100	12	12	x	x
150	20	20	x	x
200	20	25	40	25
300	30	30	70	50
400	-	50	70	60
500	-	-	95	85

- : no enzyme activity
x : not tested

C) RESULTS

(1) As indicated under (A) an enzyme electrode was constructed from the modified latex layer by treating it with glucose

oxidase. Immobilization of glyucose oxidase inside the latex-polypyrrole pore structure was achieved by agitating a modified electrode in an aqueous solution (PBS), containing the enzyme, for 4 hours and successively drying overnight. The immobilization procedure was conducted at a temperature of 277 K.

The enzyme electrodes were tested separately (viz. independent of the biosensor activity) for enzymatic activity by means of the Enzyme activity assay, described earlier. In this way, the natural cosubstrate (oxygen) was replaced by the artificial electron acceptor benzoquinone. Hydroquinone, which is formed in the catalytic cycle, was measured electrochemically at a rotating disk electrode (RDE). The regeneration of benzoquinone from hydroquinone takes place at a fixed potential (0.35 V vs. Ag/AgCl). The resulting current is a measure of the enzymatic activity. Although there is a slight raise in current caused by the spontaneous oxidation of glucose by benzoquinone, the raise in current as a result of the catalytic action of the enzyme is large enough to give a significant difference in slope of the current-time plot.

In Figure 7 the effect on the measured current is shown when a GOD treated polypyrrole-latex membrane with originally 112 nm spheres, is introduced into the electrochemical cell. This latex membrane was treated with an amount of polypyrrole corresponding to 100 mC/cm². As can be seen, the current increases immediately after introduction of the membrane. Membranes with 220 nm spheres also showed this behaviour. The fact that after withdrawal of the membrane the activity returns to its initial value, is an indication that the enzyme is properly immobilized. Not properly immobilized material would stay in solution and the slope of the line after point 2 in the figure would be higher. This assay showed that drying of the membrane after adsorption of the enzyme is essential. Enzyme was washed out completely when membranes were tested for activity directly after enzyme

treatment.

It can be concluded from the assay that adsorption of glucose oxidase to the polypyrrole surface inside the porous latex matrix, followed by drying results in proper immobilization of the enzyme with retention of enzymatic activity.

A number of enzyme electrodes based on latex and polypyrrole were tested for enzymatic activity with this assay. In Table B the results are listed for various latex membranes composed of either 112 or 220 nm spheres, containing increasing amounts of polypyrrole. The polypyrrole content is represented by the amount of charge passed in the electrochemical polymerization. It can be seen in Table B that up to a certain amount of charge enzymatically active layers are yielded after enzyme treatment. Furthermore, the activity depends on the layer thickness of the latex membranes and not on the size of the particles (i.e. when particles of 112 and 220 nm are compared). The thick layers were able to accommodate more polypyrrole before they became unfit for enzyme immobilization. This was to be expected because thicker layers contain more interspherical space than thin layers. Physical adsorption is used to immobilize the enzyme. Therefore, monolayer coverage of the polypyrrole surface is assumed. Thick latex layers contain more polypyrrole surface. Consequently, higher enzyme loading is expected. The independence of particle size probably comes from the fact that both particle sizes give rise to interspherical pores of approximately identical dimensions.

(2) Amperometric latex-polypyrrole biosensors.

In order to measure the biosensor activity of the enzyme treated latex-polypyrrole membranes, they were placed as the working electrode in an amperometric three electrode cell. The cell was part of a continuous flow system (Fig. 8), which made it feasible to switch between a buffer solution and a solution that contained the enzyme

substrate, glucose. All experiments were conducted under an argon atmosphere and 25 U/ml catalase present in all solutions. Catalase was added to eliminate any enzymatically produced H_2O_2 .

5 Except for some boundary cases, only the electrodes which showed enzymatic activity in the rotating disk electrode assay were tested as a biosensor. This means that electrodes containing thin latex layers and amounts of polypyrrole corresponding to more than 400 mC/cm^2 were not tested (Table B, columns 2,3). Thick latex layers, 10 treated with 1000 mC/cm^2 or more were also not measured as a biosensor (Table B, columns 4,5). The boundary cases were, as visible in Table B, 400 and 500 mC/cm^2 for thin and thick layers respectively.

15 The current response of the different biosensors was tested by measuring various glucose concentrations with the individual enzyme treated latex-polypyrrole electrodes. Unless stated otherwise, the amperometric measurements were performed at a potential of 0.35 V versus Ag/AgCl . The polypyrrole-latex membranes were cast on platinum. Non-specific electrochemical glucose 20 oxidation at the platinum surface could accidentally occur. Therefore, the electrodes were also tested for glucose sensitivity before they had been treated with glucose oxidase. No current response could be detected in 25 this case. Therefore, non-specific oxidation of glucose at the electrode surface did not occur.

(3) Biosensors based on thin latex layers

30 Enzyme electrodes based on latex layers of $1 \mu\text{m}$ thickness showed a relatively low activity (approximately $10 \pm 2 \text{ nA/mM}$ glucose). However, the dynamic range was very good. The current response to glucose was virtually linear in the measured range of $0\text{-}20 \text{ mM}$ (Fig. 9). The response time 35 increased with the amount of charge passed during pyrrole polymerization. The time to reach a steady-state current was less than a minute for the lowest polypyrrole content

(100 mC/cm²). When more than 400 mC/cm² of charge was passed during the polymerization, no biosensor activity was found for the resulting enzyme treated electrodes. This probably will be due to the fact that no interspherical polypyrrole surface is available anymore for enzyme adsorption. In the range of 100-300 mC/cm², the biosensor activity was virtually equal. For clarity, only one of these curves (corresponding to the sensor with 300 mC charge passed) is shown in Fig. 9. Also shown in Fig. 9 is the activity profile for a biosensor with an amount of polypyrrole corresponding to 400 mC/cm². The dynamic range of the sensor is much lower in this case. The use of 500 mC/cm² or more yielded enzymatically inactive membranes. The enzyme activity assay (Table B) showed similar activity tendencies. No significant difference in activity was found for latex membranes composed of 112 and 220 nm spheres respectively in case of these thin layers. The accessibility of the membrane to glucose oxidase seems to be a critical factor. One the pores become too small, the enzyme cannot penetrate the membrane structure anymore and immobilization does not occur.

Smaller amounts of charge than 100 mC/cm² were not investigated because the polymerization time then became too short for reproducible results. Although low current densities were used (20 mA/cm²), the polymerization time for charges under 100 mC/cm² is too short (less than 5 s) for the galvanostat. The ratio of the time to reach a constant current and the actual time the polymerization is under galvanostatic control becomes too large. During stabilization the polymerization reaction is not under galvanostatic control. This results in poorly defined polymerization conditions when the polymerization time is very short.

The reproducibility of the polypyrrole latex membrane biosensor construction was tested by repeating the experimental conditions for sensor construction. In Fig. 10 the result is shown for two membranes, containing

an amount of polypyrrole corresponding to 150 mC/cm². The calibration lines are very similar, especially at low glucose concentrations.

5 (4) Biosensors based on thick latex layers.

Thick layers (5 μm) consisting of 112 nm latex particles showed biosensor activity when treated with amounts of polypyrrole corresponding to 200-500 mC/cm². The same values apply for layers consisting of 220 nm particles. This is in concurrence with the data in Table B, where the enzymatic activity of these layers is listed. However, significant differences in the absolute values of biosensor activity were measured when the two types of latex layers (viz. with 112 and 220 nm spheres resp.) were treated with various amounts of polypyrrole. In Fig. 11 the calibration curves are shown for enzyme electrodes composed of 112 nm diameter latex particles and amounts of polypyrrole corresponding to 200 and 400 mC/cm² respectively. Lower amounts of polypyrrole were not tested (see also Table B). A polymerization time corresponding to 500 mC/cm² yielded no biosensor activity. The rotating disk assay showed some activity in this case (Table B), but probably the amount of enzyme present was not in direct contact with the conducting polymer. Consequently, no biosensor activity was measured.

Latex membranes with 220 nm particles showed somewhat different behaviour. Pyrrole deposition corresponding to 500 mC/cm² still yielded biosensor activity, while higher polypyrrole loading yielded inactive membranes (Fig. 11b). The optimum in Fig. 11b is for membranes with an amount of polypyrrole corresponding to a charge of 400 mC/cm². Lower amounts of polypyrrole yielded less active and poorly performing membranes.

The same discussion as for thin latex layers also applies for these 5 μm latex layers concerning the accessibility for GOd. When too much polypyrrole is deposited the porosity of the latex membrane is lost and

the enzyme cannot penetrate the membrane anymore. There is an optimum in the amount of incorporated polypyrrole, as shown in Fig. 11b. Lower polypyrrole loading yields less polymer surface for enzyme adsorption, leading to less active sensors.

The optimum activity of sensors based on 5 μm membranes is approximately 60 +/- 10 nA/mM glucose (calculated from the linear area). This can be compared to the activity of the 1 μm membranes (10 nA/mM glucose). The enzyme loading of the thick membranes will be higher due to the availability of more conducting polymer surface, leading to an increased activity.

(5) Characterization of optimized latex-polypyrrole biosensors.

The biosensors which displayed the highest activity (vide supra) were characterized further. The dynamic range of these biosensors was tested by measuring a large range of glucose concentrations and the lifetime under quasi-continuous operation was evaluated.

Steady state current measurements were made in the same way as described above. Glucose concentrations up to 80 mM were measured. Fig. 12a shows the response curve for a 1 μm latex layer with 220 nm particle size, covered with an amount of polypyrrole corresponding to 150 mC/cm². In this case the current response to glucose was virtually linear up to 20 mM. The various amounts of polypyrrole on 112 and 220 nm particles tested gave similar calibration lines as in Fig. 12a. This reproducible behaviour is lost upon going to 5 μm thick latex membranes. For the optimal latex-polypyrrole combinations a large difference in dynamic response is obtained for the different dimensions of the latex particles (Fig. 12b). The dynamic range of sensors based on 220 nm particles is 60 mM, with a linear current response to glucose up to 10 mM (Fig. 12b, solid line). From Fig. 12b (dashed line) it can be seen that the calibration curve for the sensor with 112 nm latex beads

reveals a dynamic range of about half this value. The linearity on glucose concentration is less than 5 mM.

The response time of the biosensors depended on the amount of polypyrrole present, the thickness of the latex layer, and the particle size of the latex beads. The various response times were evaluated by measuring 5 mM glucose and are summarized in Table C. The response time is defined as the time needed to reach 95 % of the steady state current. It should be noted that this time is slightly dependent on glucose concentration. However, the difference in response time for the measurement of, e.g., 2 mM and 20 mM glucose was less than approximately 5 s.

(6) Selectivity and lifetime.

The sensitivity of the sensor to fructose, citrate, lactate, urea, uric acid and pyruvate was tested separately. No significant response was observed to any of these components when they were present at concentrations of 5 mM. Ascorbate (vitamin C), a common interferent in amperometric biosensors, interfered strongly when present at 5 mM concentration. However, in real samples the ascorbate concentration is usually much lower, e.g. in milk; 0.1 mM. The current response of freshly prepared biosensors was tested for prolonged periods of time. The sensors were taken up in a flow system which was at room temperature. The carrier stream contained 2 mM glucose. Therefore, this concentration of glucose was continuously measured during the lifetime experiment. To determine the biosensor activity a glucose concentration of 5 mM was introduced in the carrier stream and the increase in current was measured. In this way we were able to account for any deviations due to baseline drift and still the sensor lifetime was evaluated under continuous operation. In Fig. 13 the sensitivity of a latex-polypyrrole biosensor (220 nm, thick layer, 400 mC/cm²) to 5 mM glucose is plotted as a function of time. The current response is not stable during the first days of measurement. Probably,

in the beginning an amount of enzyme which is less firmly bound is slowly washed out. After 3 days, the sensor response remained the same for 10 days. This stability is sufficient for disposable applications.

5

(7) Electrochemical analysis of the latex biosensor.

Measurements of biosensor activity were performed under argon at low potentials (0.10 - 0.35 V) in a continuous flow system. No additional mediators were present and any flavine cofactor, dissociated from the enzyme, would be washed out immediately. Therefore, the accidental mediation of electron transfer by free flavine molecules was not possible. The only low molecular weight mediator that could still be present in the system is oxygen.

10

15

20

However, we found no significant difference in activity when measurements under ambient atmosphere were compared with measurements under argon. Fig. 14 shows a typical plot of the response (0.35 V vs. Ag/AgCl) under an argon atmosphere and the use of argon flushed solutions (solid line) and under ambient atmosphere with air saturated solutions (dashed line). The difference is less than 6 % and is within the range of experimental error.

25

30

35

Oxygen competition would lead to hydrogen peroxide formation. At sufficiently low anodic potentials this would cause a strongly negative response, because H_2O_2 is reduced. This causes a large catalytic current to flow as is shown in Figure 15, in which the response of a sensor membrane to 10 mM glucose is compared with the response of the same membrane to 0.0025% H_2O_2 at a potential of 0.10 V vs. Ag/AgCl. Due to the addition of H_2O_2 a very large negative current flows (Figure 15). However, the addition of glucose still leads to a positive response. The formation of even the smallest amount of hydrogen peroxide during enzymatic glucose oxidation would have eliminated or probably inverted the current response to glucose. Therefore, we can conclude that no significant oxygen mediation takes place and that the measured current is due

to direct communication between glucose oxidase and polypyrrole.

5 Considering the fact that the conducting polymer mediated the electron transport from the enzyme directly (i.e. no additional mediators were present), the working potential (maximum 0.35 V versus Ag/AgCl reference) of the latex-polypyrrole membrane electrodes was very low.

10 Polypyrrole is electroactive in its oxidized state and the charge carried by the conducting polymer can be cycled repetitively. The confined space in the interspherical pores of the latex apparently brings the active centers of the enzyme molecules in close contact with the conducting polymer. The adsorption process should play an important role in this by allowing the enzyme to penetrate the surface of polypyrrole. Applicant has found that drying after enzyme treatment of the membrane was essential for both the immobilization of enzyme and the direct electron transfer. Water is likely to be a competing species with regard to adsorption on the polymer surface. When water is removed by evaporation, enzyme adsorption is favoured and the active centers of the enzyme can approach the conducting polymer sufficiently to make direct communication possible. Electrostatic interactions could also play an important role in the immobilization process. Polypyrrole in its conducting state is a polycation. Glucose oxidase in neutral solution has in its turn at least 10 negative charges on its surface (pI is 4.1). Therefore, electrostatic interactions may be very strong. Because of these features the electroactive sites on the conducting polymer could strongly interact with the enzyme thereby making direct electron transfer possible.

25 (8) Conclusions

35 Amperometric glucose biosensors can be constructed from polypyrrole modified latex layers which are cast on a platinum electrode. Adsorption of glucose oxidase on the interspherical polypyrrole surface leads to immobilization of the redox protein without loss of enzymatic activity.

5 the response to glucose of this biosensor probably is the
result of direct electron transfer between glucose oxidase
and polypyrrole. The confined space in the pores between
the latex spheres, together with the surface morphology of
polypyrrole make this possible. Electrostatic interactions
contribute to this property. Measurements under argon and
oxygen atmosphere show no significant difference in
current response. The response to hydrogen peroxide at
10 relatively low anodic potential (i.e. 0.10 V vs. Ag/AgCl)
is negative, while the glucose response is positive at
this potential. This reveals that oxygen mediation does
not take place. The absence of H₂O₂ production and the
stabilisation of the enzyme by the special polypyrrole
environment results in a biosensor with a considerable
15 lifetime under continuous use.

The principle of immobilizing redox enzymes by
adsorption on a conducting polymer surface inside the
pores of latex layers can be applied to many combinations
of redox enzymes and conducting polymers. The principle of
20 sensor construction can be utilized to develop disposable
sensors. The stability of the sensor is sufficient for
this purpose.

CLAIMS

1. Electrode, provided with a polymer coating having a redox enzyme bound thereto, characterized in that the electrode is composed of a membrane, provided with open pores running through said membrane, the walls of the pores having an electrically conducting polymer coating, which polymer coating is in direct electronic contact with a redox enzyme bound thereto.

2. Electrode according to Claim 1, characterized in that one side of the membrane has been provided with a conducting layer, which layer is in contact with the polymer coating.

3. Electrode according to Claim 2, characterized in that the conducting layer is made of a metal or carbon.

4. Electrode according to Claim 3, characterized in that the conducting layer is made of platinum.

5. Electrode according to Claim 3 or 4, characterized in that the metallic conducting layer has a thickness of 100-500 nm.

6. Electrode according to any one of Claims 1-5, characterized in that the membrane consists of a porous inert polycarbonate or polyester material.

7. Electrode according to Claim 6, characterized in that the membrane is provided with pores having a diameter of 100-1000 nm and has a porosity of 10^5 - 3×10^8 pores/cm².

8. Electrode according to any one of the Claims 1-5, characterized in that the membrane is manufactured on the basis of latex particles.

9. Electrode according to Claim 8, characterized in that the latex particles have a diameter in the range of 50-1000 nm.

10. Electrode according to Claim 9, characterized in that the latex particles have a diameter in the range of 50-300 nm.

11. Electrode according to any one of the Claims 8-10, characterized in that the latex is a polystyrene latex or a polymethyl methacrylate latex.

12. Electrode according to any one of the Claims 8-10, characterized in that the latex is a silica latex.

13. Electrode according to one or more of Claims 1-12, characterized in that the electrically conducting polymer is polypyrrole.

5 14. Electrode according to Claim 13, characterized in that the polypyrrole coating has a thickness of 50-200 nm.

15. Electrode according to one or more of Claims 1-14, characterized in that the redox enzyme is anoxidase.

16. Electrode according to Claim 15, characterised in that the redox enzyme is a dehydrogenase.

10 17. Method for the detection of specific substances such as glucose in samples, characterised in that a biosensor containing the electrode according to one or more of Claims 1-16 is used in said method, which electrode contains a redox enzyme suitable for the purpose.

15 18. Method for the preparation of specific substances such as gluconic acid, characterised in that an electrochemical installation containing the electrode according to one or more of Claims 1-16 is used in said method, which electrode contains a redox enzyme suitable for the purpose.

20

fig - 1

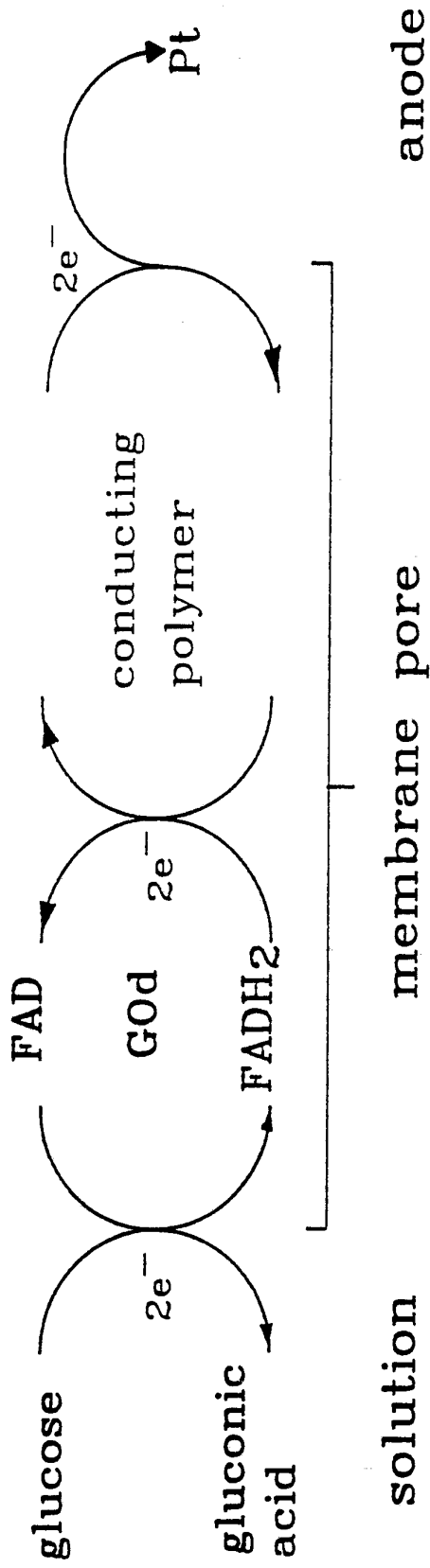

fig - 2a



fig-2b



fig-2c



Fig-61f

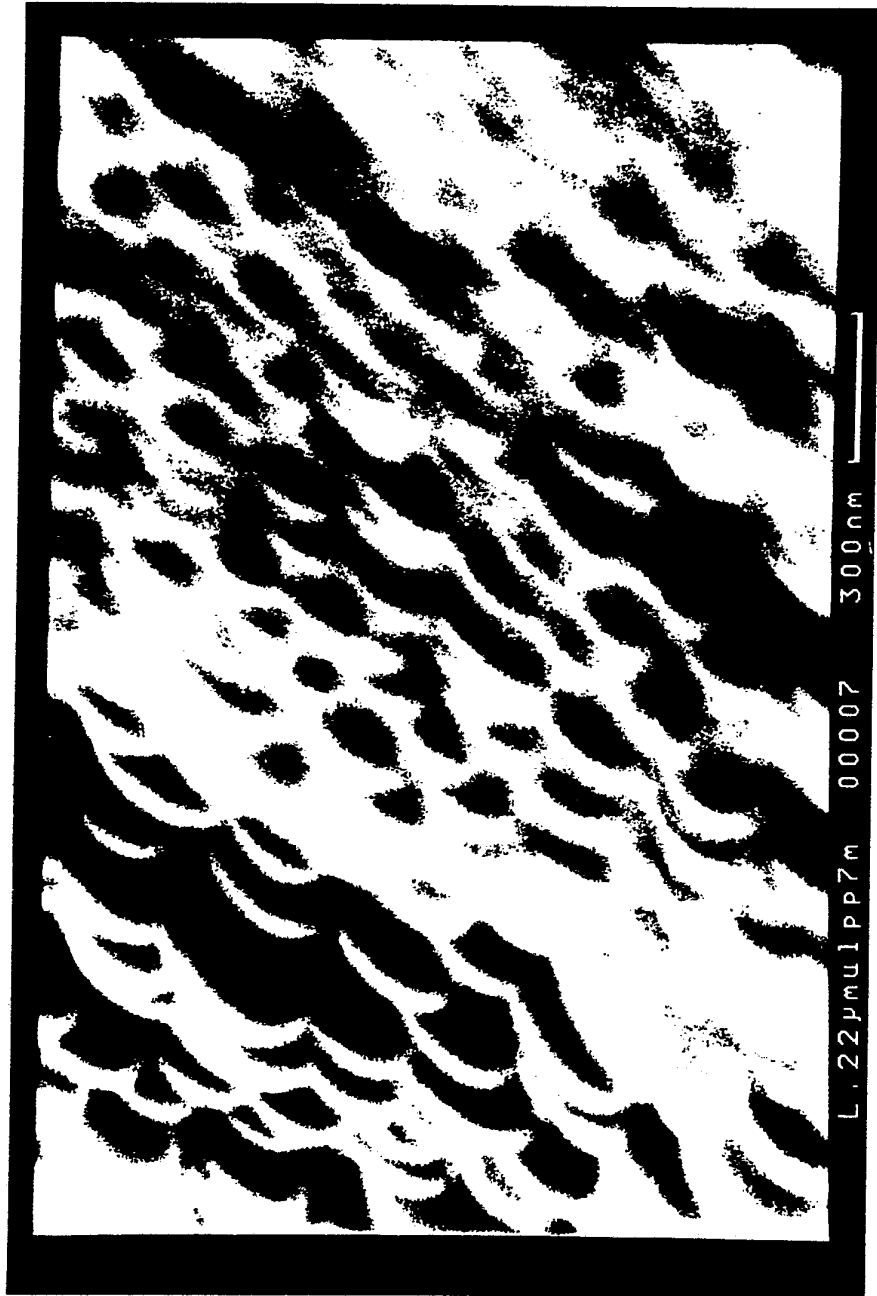

fig-3

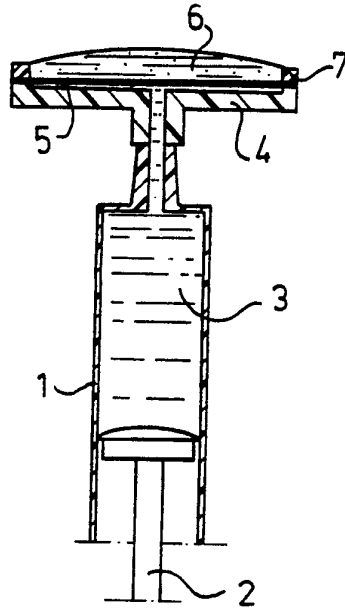
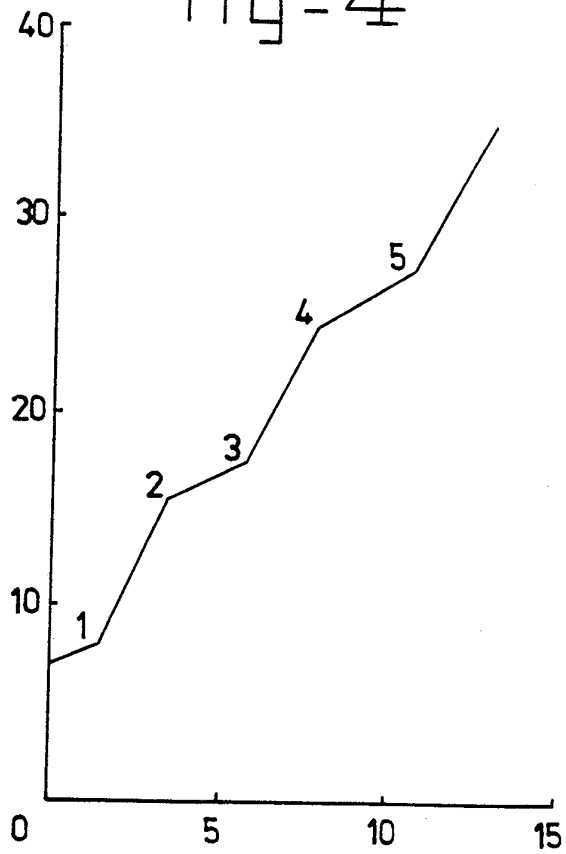

fig-4



7/17

fig-5

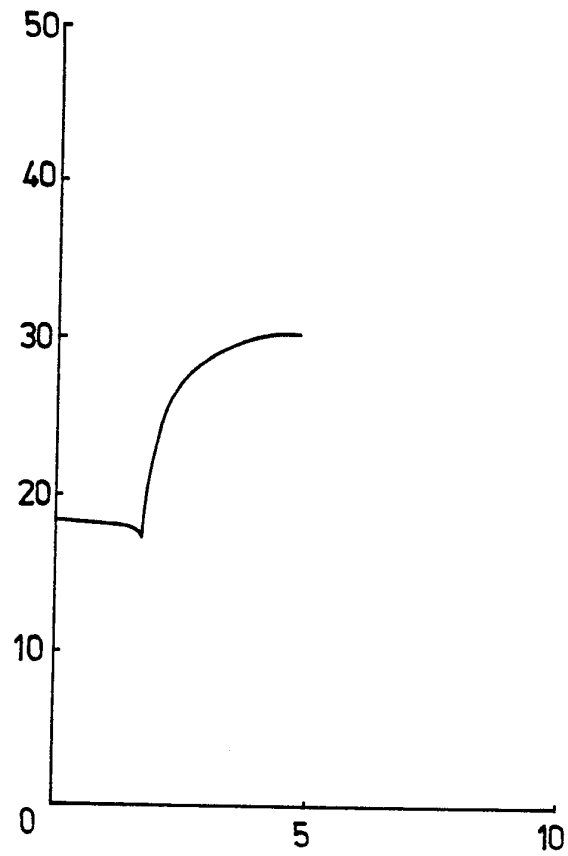
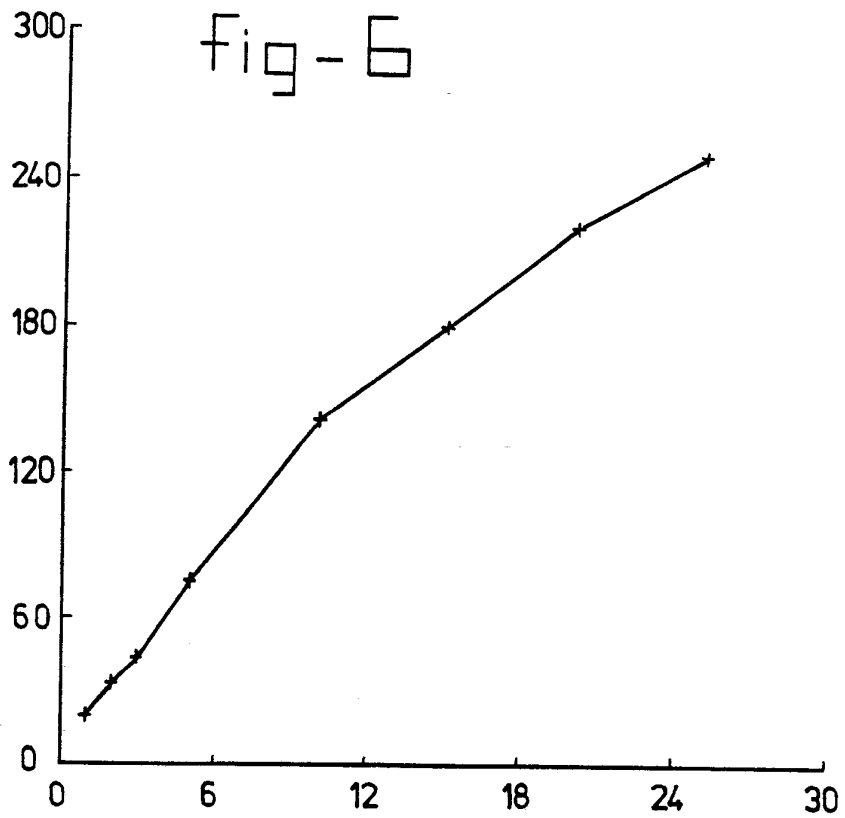

fig-6



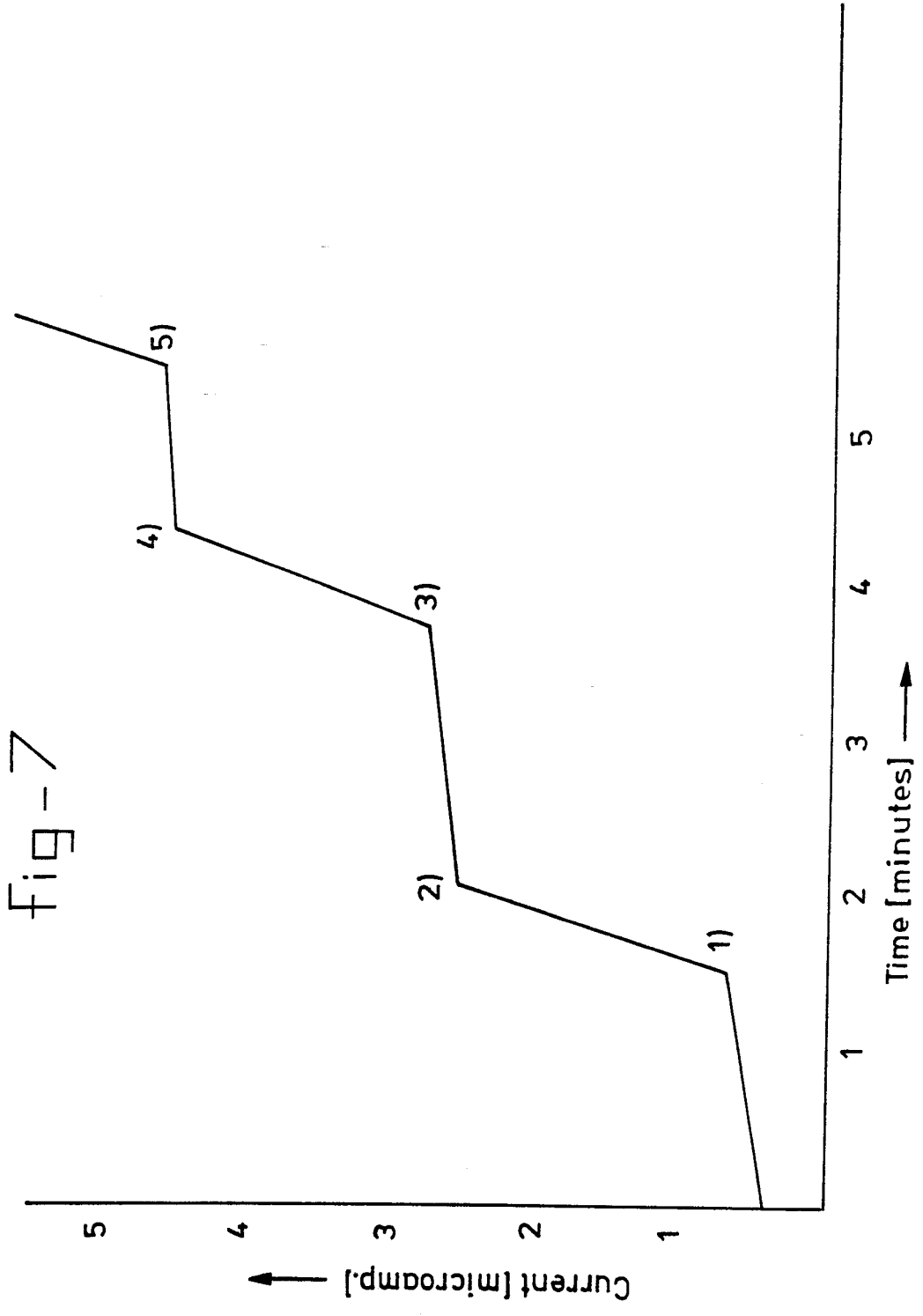

fig - 8

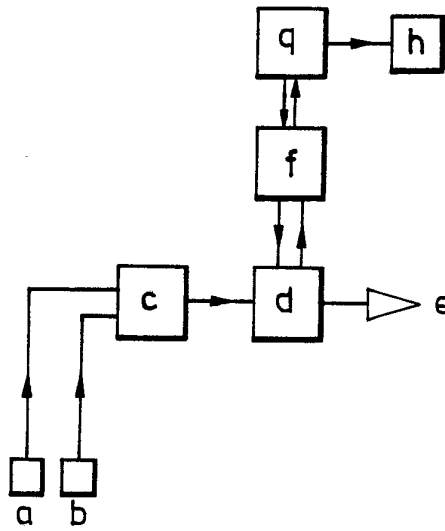
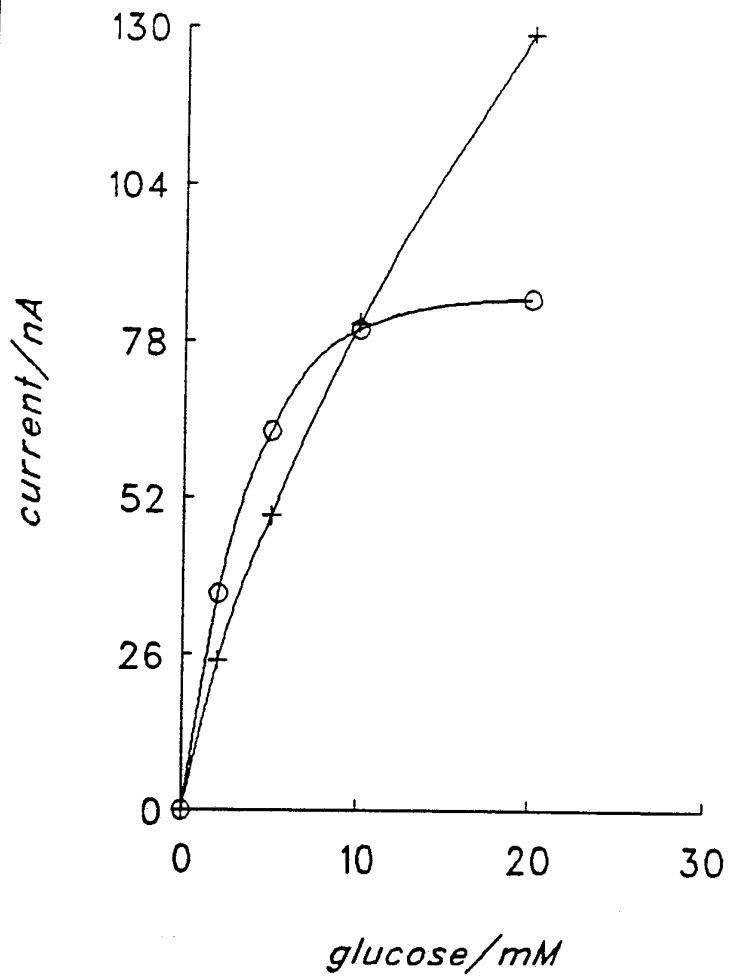
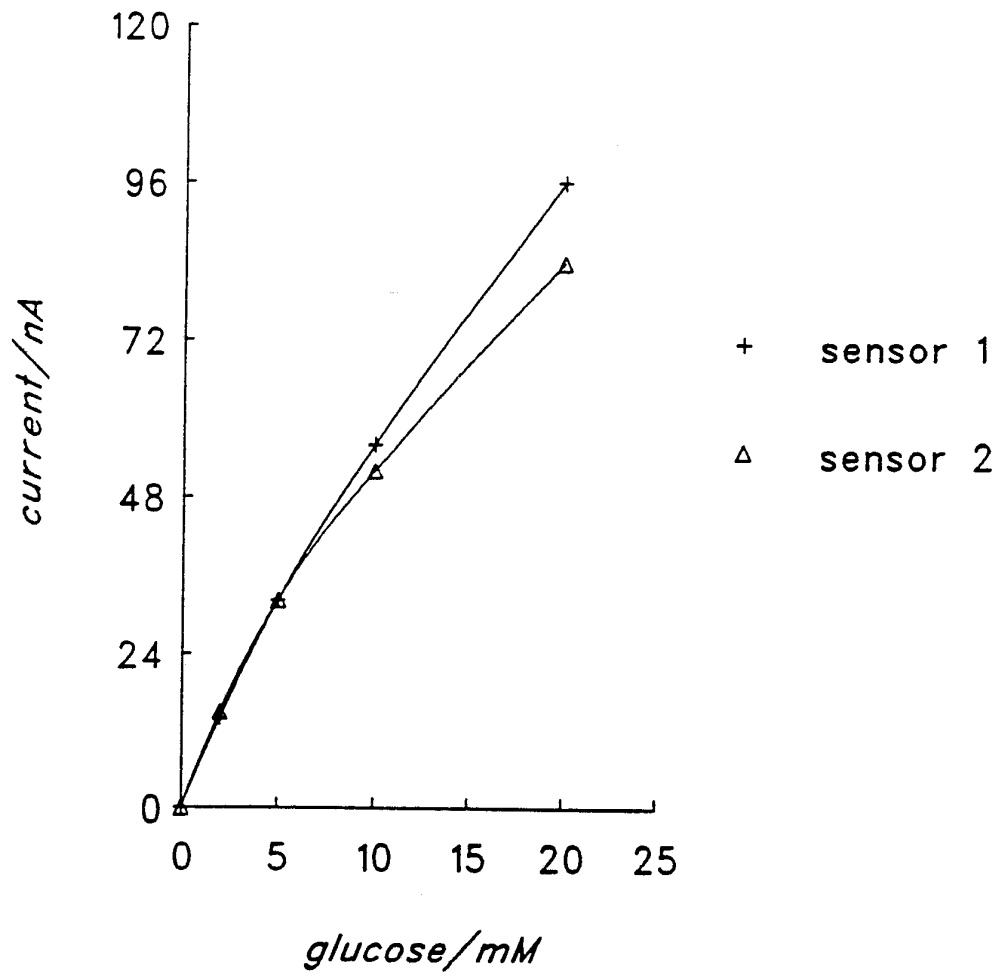

fig - 9



10/17

fig-10



11/17

fig-11a

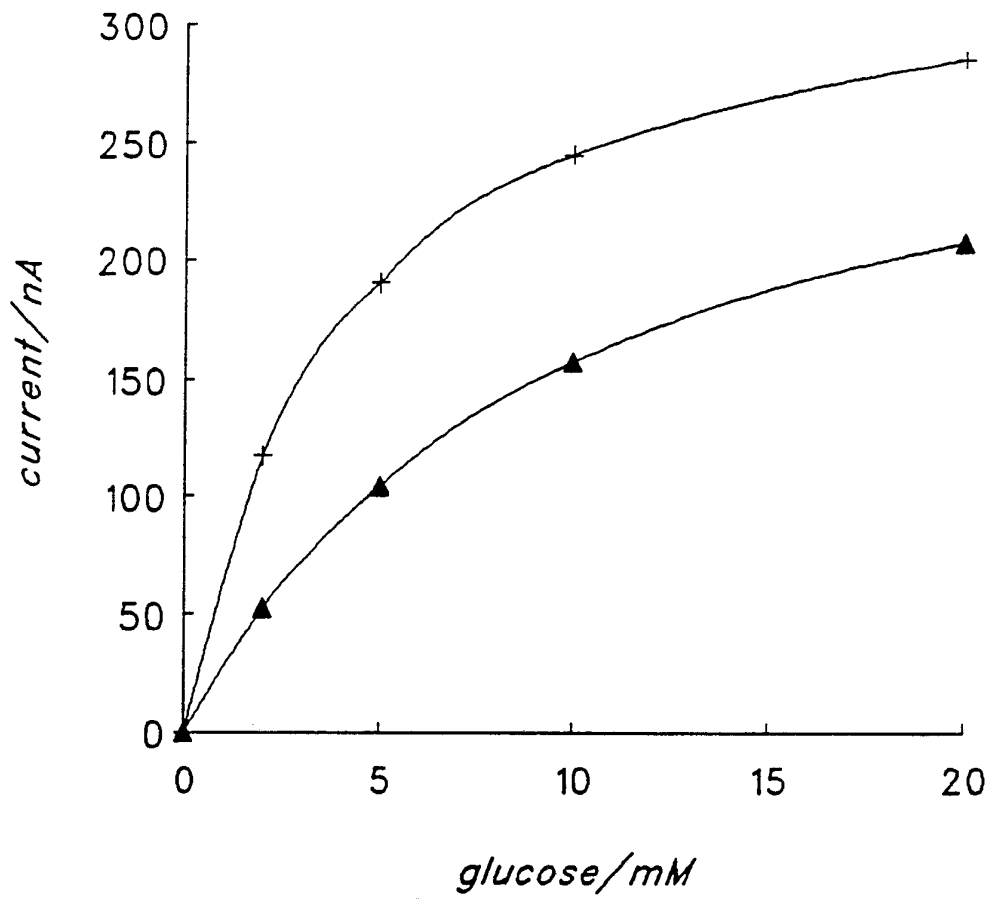

12/17

fig - 11b

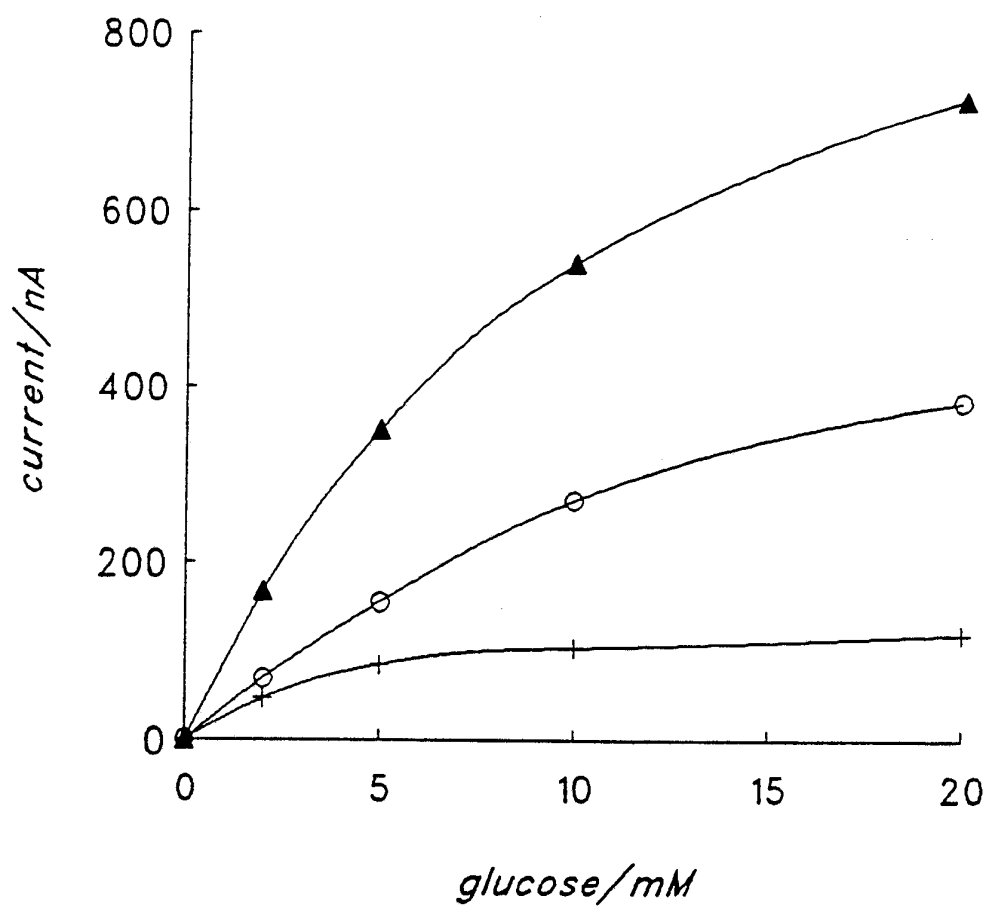

fig-12a

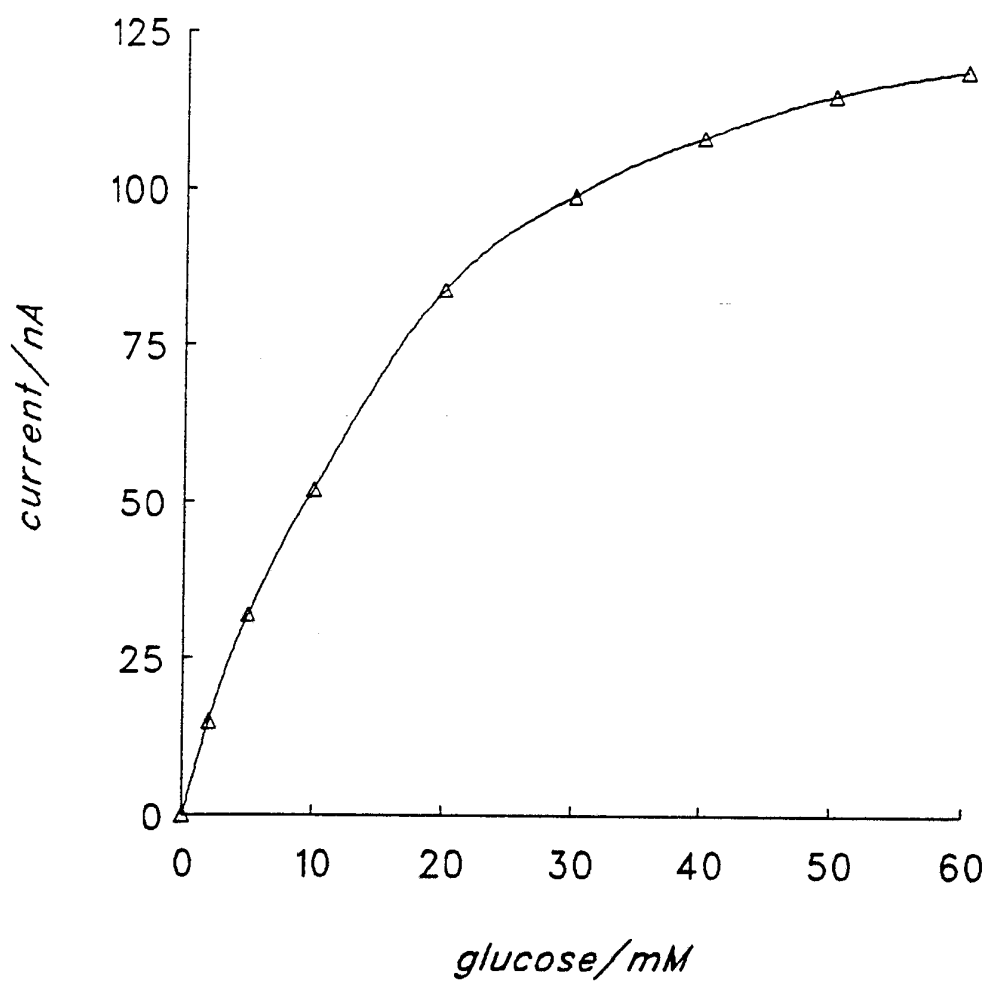

fig - 12b

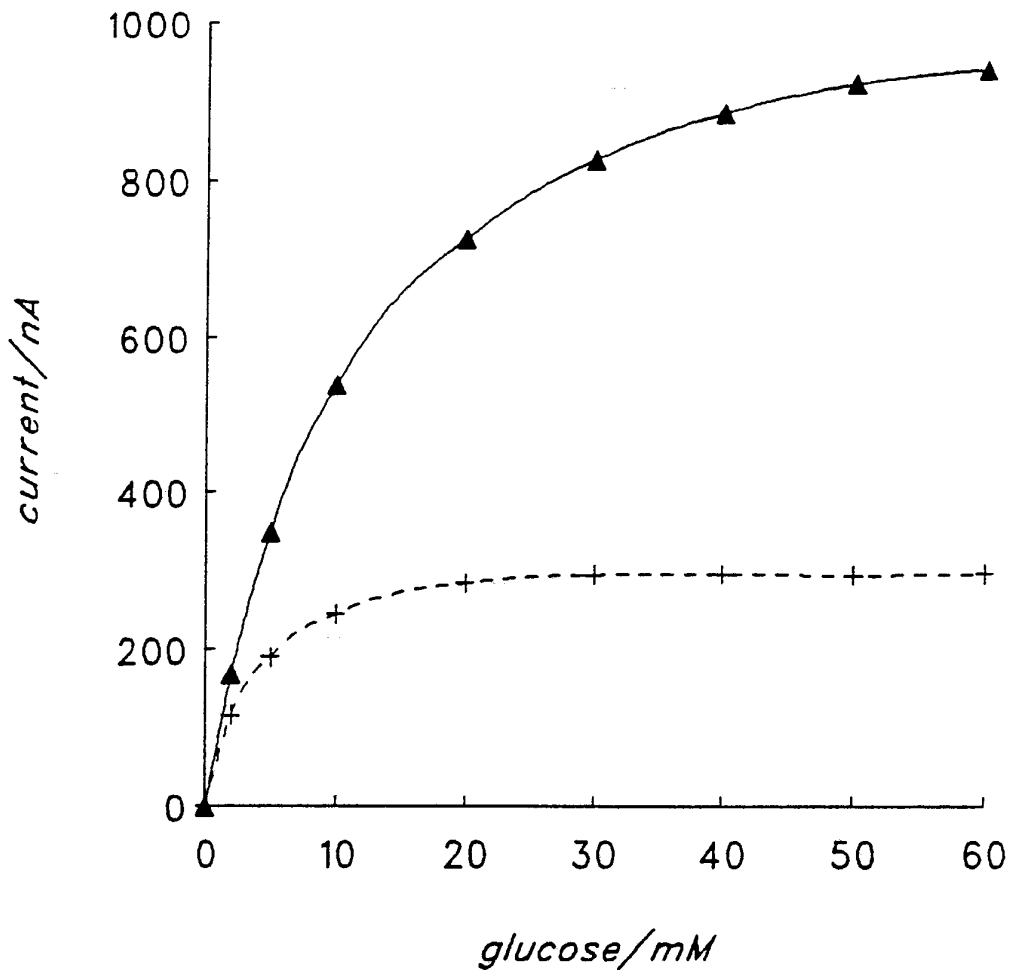

fig-13

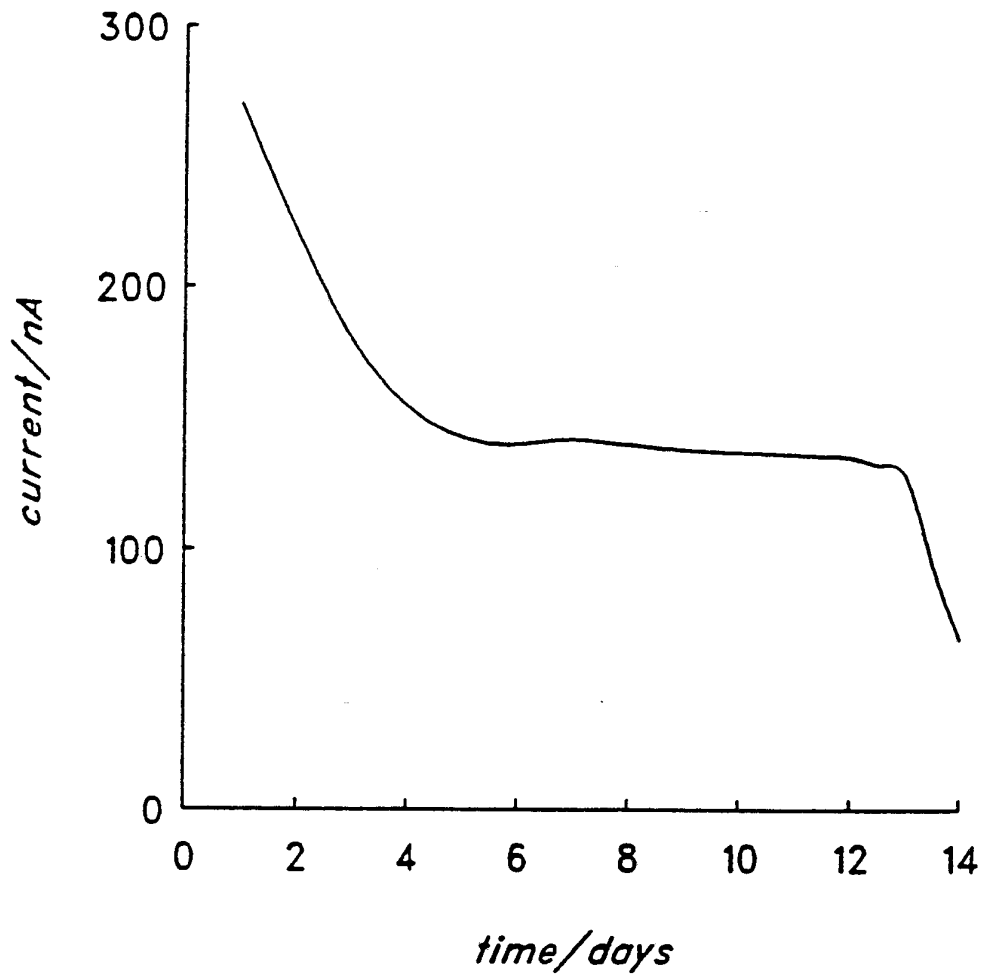

fig-14

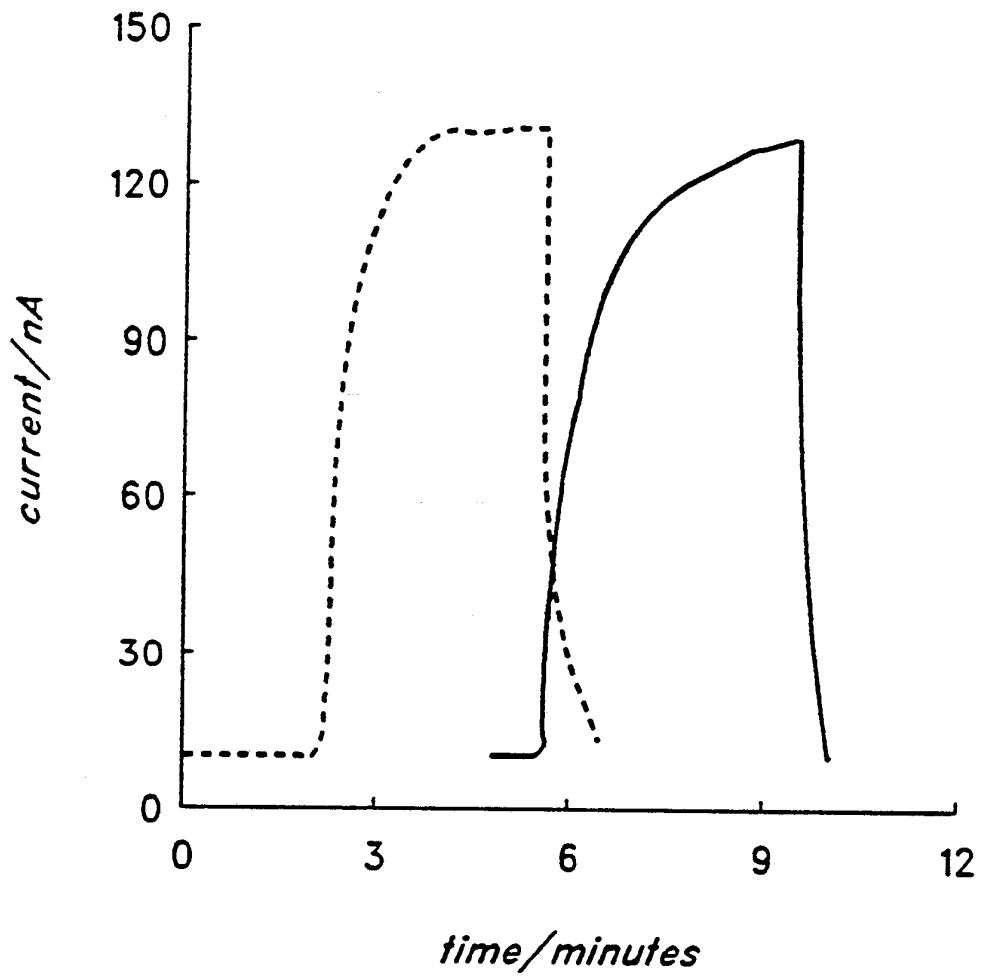
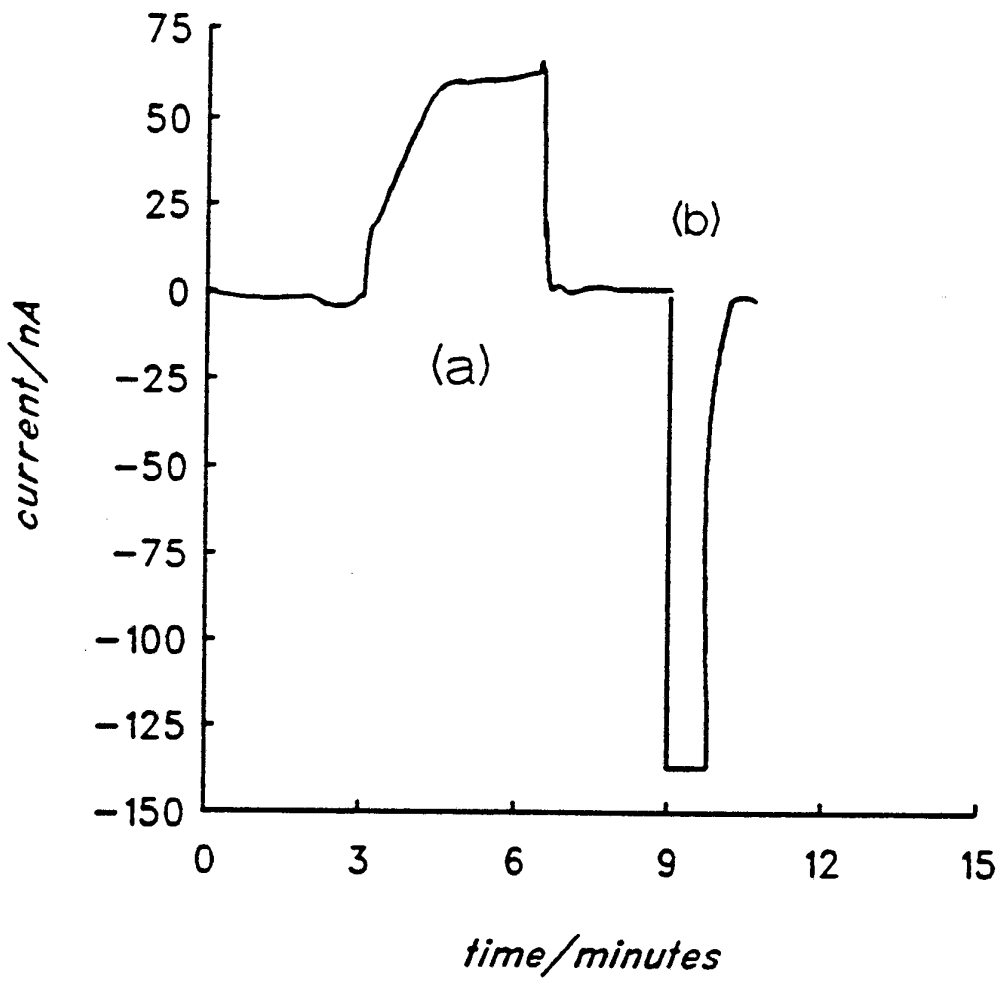

fig - 15



INTERNATIONAL SEARCH REPORT

DT/NL 91/00263

International Application No

I. CLASSIFICATION OF SUBJECT MATTER (if several classification symbols apply, indicate all) ⁶		
According to International Patent Classification (IPC) or to both National Classification and IPC		
Int.Cl. 5 C12Q1/00; C12M1/40		
II. FIELDS SEARCHED		
Minimum Documentation Searched ⁷		
Classification System	Classification Symbols	
Int.Cl. 5	C12Q ; C12M	
Documentation Searched other than Minimum Documentation to the Extent that such Documents are included in the Fields Searched ⁸		
III. DOCUMENTS CONSIDERED TO BE RELEVANT ⁹		
Category ¹⁰	Citation of Document, ¹¹ with indication, where appropriate, of the relevant passages ¹²	Relevant to Claim No. ¹³
Y	US,A,4 582 575 (L.F. WARREN ET AL.) 15 April 1986 cited in the application see column 2, line 11 - line 48 see column 4, line 14 - line 15 see column 3, line 1 - line 16 ---	1-18
Y	PATENT ABSTRACTS OF JAPAN vol. 13, no. 12 (P-812)(3360) 12 January 1989 & JP,A,62 053 573 (MEITETSUKU K.K.) 12 September 1988 see abstract ---	1-18
Y	PATENT ABSTRACTS OF JAPAN vol. 9, no. 16 (P-329)(1739) 23 January 1985 & JP,A,59 164 953 (FUJI DENKI SOUGOU KENKYUSHO K.K.) 18 September 1984 see abstract ---	1-18
	-/--	
<p>¹⁰ Special categories of cited documents : 10</p> <p>"A" document defining the general state of the art which is not considered to be of particular relevance</p> <p>"E" earlier document but published on or after the international filing date</p> <p>"L" document which may throw doubts on priority claim(s) or which is cited to establish the publication date of another citation or other special reason (as specified)</p> <p>"O" document referring to an oral disclosure, use, exhibition or other means</p> <p>"P" document published prior to the international filing date but later than the priority date claimed</p> <p>"T" later document published after the international filing date or priority date and not in conflict with the application but cited to understand the principle or theory underlying the invention</p> <p>"X" document of particular relevance; the claimed invention cannot be considered novel or cannot be considered to involve an inventive step</p> <p>"Y" document of particular relevance; the claimed invention cannot be considered to involve an inventive step when the document is combined with one or more other such documents, such combination being obvious to a person skilled in the art.</p> <p>"&" document member of the same patent family</p>		
IV. CERTIFICATION		
Date of the Actual Completion of the International Search	Date of Mailing of this International Search Report	
27 MARCH 1992	10.04.92	
International Searching Authority	Signature of Authorized Officer	
EUROPEAN PATENT OFFICE	VAN BOHEMEN C.G. <i>P. van B.</i>	

III. DOCUMENTS CONSIDERED TO BE RELEVANT (CONTINUED FROM THE SECOND SHEET)		Relevant to Claim No.
Category °	Citation of Document, with indication, where appropriate, of the relevant passages	
A	<p>ANALYTICAL CHEMISTRY vol. 58, 1986, WASHINGTON DC USA pages 2979 - 2983; M. UMANA ET AL.: 'Protein-modified electrodes. The glucose / polypyrrole system.' cited in the application see the whole document</p> <p>---</p>	1-18
A	<p>JOURNAL OF THE CHEMISTRY SOCIETY, CHEMICAL COMMUNICATIONS no. 14, 1989, USA pages 945 - 946; S.I. YABUKI ET AL.: 'Electro-conductive enzyme membrane.' see the whole document</p> <p>---</p>	1-18

**ANNEX TO THE INTERNATIONAL SEARCH REPORT
ON INTERNATIONAL PATENT APPLICATION NO. NL 9100263
SA 54853**

This annex lists the patent family members relating to the patent documents cited in the above-mentioned international search report. The members are as contained in the European Patent Office EDP file on
The European Patent Office is in no way liable for these particulars which are merely given for the purpose of information. 27/03/92

Patent document cited in search report	Publication date	Patent family member(s)	Publication date
US-A-4582575	15-04-86	None	
