

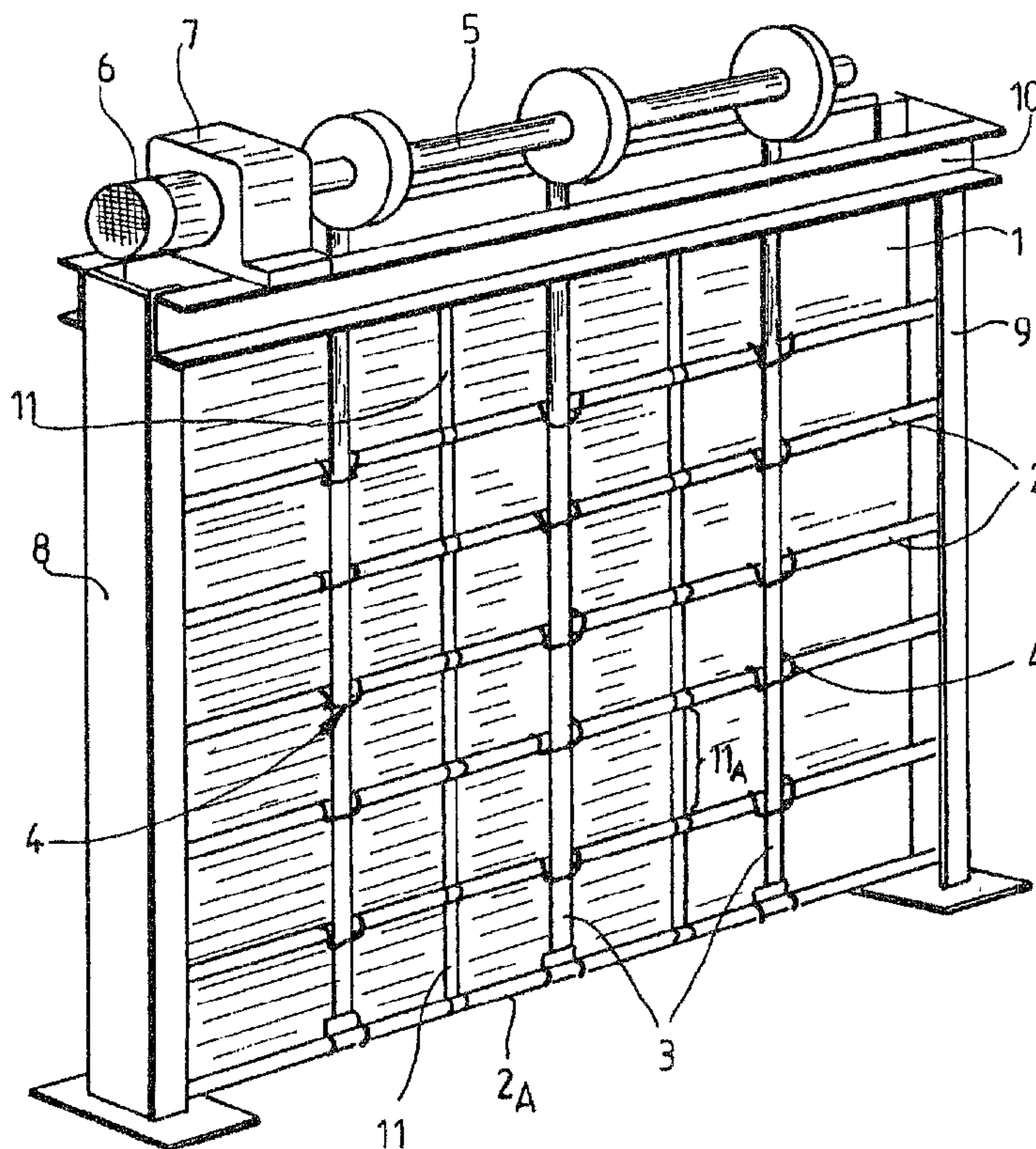

(22) Date de dépôt/Filing Date: 1990/08/10  
 (41) Mise à la disp. pub./Open to Public Insp.: 1991/02/12  
 (45) Date de délivrance/Issue Date: 2003/06/03  
 (62) Demande originale/Original Application: 2 023 132  
 (30) Priorité/Priority: 1989/08/11 (89-10803) FR

(51) Cl.Int.<sup>5</sup>/Int.Cl.<sup>5</sup> E06B 9/56  
 (72) Inventeur/Inventor:  
KRAEUTLER, BERNARD, FR  
 (73) Propriétaire/Owner:  
NERGECO (SA), FR  
 (74) Agent: OGILVY RENAULT

(54) Titre : PORTE SOUPLE RELEVABLE  
 (54) Title: VERTICALLY RAISABLE CURTAIN DOOR



(57) Abrégé/Abstract:

A goods-handling door comprises a raisable curtain 1 which folds concertina-like and which is stiffened by reinforcing bars 2 having rings 4 through which lifting straps 3 are passed, which straps are wound onto a top shaft 5 of a drive unit 6, 7. At the bottom of the curtain, a small additional piece of curtain is provided with a flexible reinforcing bar that is not connected to the lifting straps. The flexible reinforcing bar may be constituted by a coil spring, by a plastic extrusion, etc. It serves as a ballast, as a feeler bar, etc., while remaining flexible.

Abstract

A goods-handling door comprises a raisable curtain 1 which folds concertina-like and which is stiffened by reinforcing bars 2 having rings 4 through which lifting straps 3 are passed, which straps are wound onto a top shaft 5 of a drive unit 6, 7. At the bottom of the curtain, a small additional piece of curtain is provided with a flexible reinforcing bar that is not connected to the lifting straps. The flexible reinforcing bar may be constituted by a coil spring, by a plastic extrusion, etc. It serves as a ballast, as a feeler bar, etc., while remaining flexible.

## VERTICALLY RAISABLE CURTAIN DOOR

## BACKGROUND OF THE INVENTION

The present invention relates to goods-handling doors of the type comprising a raisable curtain, and more particularly to raisable doors that fold concertina-like, comprising a flexible curtain having horizontal reinforcing bars disposed at regular intervals, lifting straps fixed to the bottom bar and passing through rings fixed to at least some of the other bars, and drive means including a shaft disposed above the curtain and onto which the straps are wound. The edges of the curtain and/or the ends of the reinforcing bars are capable of moving in slideways formed in or by lateral uprights which support a top horizontal cross member on which the strap-winding shaft is mounted, possibly together with an electric motor and control members for the motor. It is known that flexible and inextensible means generally in the form of a strip may be provided between adjacent pairs of bars in order to limit the extent to which the bars move apart when the curtain is in its closed position, while not preventing adjacent bars moving towards one another while the curtain is being raised.

One of the problems that arises with a curtain of this nature lies in the folding that takes place when the curtain is raised, both during the raising motion itself and when in the folded position.

When all of the reinforcing bars are provided with rings through which the lifting straps pass, it may happen, e.g. under the influence of wind pressure, that the curtain material folds wrongly going between the bars, and this damages the material and prevents the bars being properly stored side by side in the raised position of the curtain.

Proposals have been made to provide strap-guiding rings on every other bar only. Proper folding is achieved more often in this way, but during curtain-raising, the bundle of bars without rings hangs beneath the bottom bar to which the lifting straps are attached. In the event of unintended wrong operation, a vehicle or a person may strike this bundle of bars or may have it dropped onto them, and the consequences of such an accident may be serious.

## SUMMARY OF THE INVENTION

It is therefore an aim of the present invention to provide an improved vertically raisable curtain door.

Therefore, a vertically raisable curtain door in accordance with the present invention is of the type comprising a flexible curtain having horizontal reinforcing bars disposed at regular intervals, and a drive unit which includes a winding shaft. At the bottom of the curtain, there is provided a small additional piece of curtain with a flexible reinforcing bar for serving as a ballast or as a feeler bar.

In another construction in accordance with the present invention, a vertically raisable curtain door which is foldable concertina-like is of the type comprising a flexible curtain which has horizontal reinforcing bars disposed at regular intervals. The door also comprises lifting straps fixed to the bottom bar and passing through guide rings fixed to at least some of the bars. The door further comprises a drive unit including a strap winding shaft. At the bottom of the curtain, there is provided a small additional piece of curtain with a flexible reinforcing bar that is not connected to the lifting straps for serving as a ballast or as a feeler bar.

In a more specific construction in accordance with the present invention, the flexible reinforcing bar is constituted by a coil spring.

Further in accordance with the present invention, there is provided a goods-handling door comprising:

two vertical lateral uprights, each of them having a vertical slideway;

a raisable flexible curtain having a bottom edge;

curtain lifting means including an electric motor for lifting said curtain in order to leave way to a person or a goods-handling vehicle;

a plurality of horizontal reinforcing bars, each of said bars being fixed to said curtain;

each of said reinforcing bar having two ends which slide in said slideways, said plurality of reinforcing bars including intermediate reinforcing bars and a lowermost reinforcing bar disposed at a distance above said bottom edge of said curtain; and an additional, flexible bar, disposed at said bottom edge of said curtain so that a shock received at the bottom edge of the curtain will not injure a person or damage a goods-handling vehicle.

#### BRIEF DESCRIPTION OF THE DRAWINGS

An embodiment of the invention is described by way of example with reference to the accompanying drawings, in which:

Figure 1 is a perspective view of an example of a curtain door in accordance with the present invention;

Figure 2 is a perspective view of one example of a reinforcement device made of molded plastic to which the present invention is applicable;

Figure 3 is a view analogous to Figure 2 but applies to a different example;

Figures 4A and 4B are section views on lines A-A and B-B of Figure 3; and

Figure 5 is a fragmentary cross-section through a curtain of the present invention in a partially raised position.

5

## DETAILED DESCRIPTION

In order to situate the present invention, Figure 1 shows a conventional type of curtain door. A curtain 1 is reinforced by horizontal reinforcing bars 2 disposed at regular intervals. Lifting straps 3 are fixed to the bottom bar 2A and pass  
10 through rings 4 fixed to the other bars. A drive unit comprises a shaft 5 on which the straps are wound and a motor 6, in practice an electric motor together with a transmission 7. Other components for the end-of-stroke detection, relays, etc., are conventional in this application are not shown. The  
15 ends of the bars and possibly also the edges of the curtain move in slideways 8, 9 formed in or constituted by lateral vertical uprights. A top cross-member 10 constituted in this case by two rolled steel girders interconnects the tops of the uprights and supports the shaft 5 onto which the straps are  
20 wound. The motor 6, 7 may also be placed on the cross-member. Frequently the curtain 1 is made of flexible non-reinforced plastic material and the weight of the bars (and their inertia) may cause the material of the curtain to be deformed and stretched. That is why reinforcing or "equidistance" straps 11

are provided which are placed against the curtain and fixed to each bar.

When the shaft 5 is winding up the straps, the bottom bar 2A is raised and at consecutive intervals it reaches each successive bar so that it entrains first one, then two, etc., and finally all of the bars upwards. The curtain 1 folds between the bars. If it folds away from the lifting strap 2, then the folds are formed properly, the curtain material is not pinched, and when fully raised, the bars are placed against one another to occupy a relatively small vertical extent at the top of the doorway. However, if the wind or air pressure should thrust the curtain against the lifting straps, then folding takes place badly. The curtain material is pinched and damaged, and when fully raised the bars are kept apart by bundles of badly formed folds. The present invention is designed to avoid this drawback.

In accordance with the present invention, and as shown in Figure 1, all of the bars 2 are provided with rings 4 for receiving each of the lifting straps 3, and each inter-bar element 11A of the equidistance straps 11 is flexible and inextensible in structure, thereby facilitating folding in a direction away from the lifting straps, each of said equidistance strap elements being fixed to the material of the curtain or being placed on the same side as the lifting straps, with the two ends of each element 11A being fixed to two adjacent bars.

Each element may be constituted, for example, by a thin strip of preformed flexible spring steel which is easily flattened out when the curtain is extended vertically and which curves in the desired direction when the bar beneath it is raised. Alternatively, each element may be constituted by a strip of plastic molded to the shape of the desired fold.

Other examples are shown in Figures 2 to 4. In Figure 2, the equidistance element shown is made of molded plastic material, e.g. polypropylene, polyurethane, polyvinyl chloride, or the like. It is generally in the form of a strip whose ends 11B and 11C are designed to be fixed on adjacent bars, e.g. by

means of appropriate sleeves. Its middle portion 15 is intended to form the fold or to direct the fold and on one side (to the front in Figure 1) it has a smooth surface whereas on its other side it is shaped with transverse grooves or slots 15A that facilitate folding to bring together the two ends by moving them downwards in Figure 2. In contrast, in the opposite direction, the slot 15A closes and prevents the strip from folding in the wrong direction. The part may additionally be molded with a degree of preshaping or curvature, thereby further facilitating folding in the proper direction. The end zones 16 and 17 of the strip are stiffened by longitudinal grooves or ribs 16A, 17A on one of its two faces, thereby ensuring that the folding shown in Figure 5 is obtained, which figure is a diagrammatic section through a partially raised curtain. It can be seen that it may be advantageous for the top stiff portion 16 to be longer than the bottom stiff portion 17 on either side of the folding portion 15, given the offsets due to the bars.

Another example is shown in Figures 3 and 4. A strip of molded rubber 25 is reinforced over its faces by inextensible fibers, e.g. cables made of steel or rayon. On one face, e.g. the top face, steel cables 26 are embedded in the rubber over the entire length of the strip. On the bottom face, cables 26 are disposed transversely (section BB in Figure 4B) in the middle zone and they are close together so as to form an incompressible structure, whereas in the end zones (section AA) the cables 28 are disposed longitudinally. The end zones are thus fairly rigid whereas the middle zone is capable of folding in the direction such that its ends are raised, but not in the opposite direction.

At the bottom of the curtain of Figs. 1 and 5, a small additional piece of curtain is provided in accordance with the present invention with a flexible reinforcing bar 2A that is not connected to the lifting straps. For example, this bar may be constituted by a coil spring, by a plastic extrusion, etc. It serves as a ballast, as a feeler bar, etc., while remaining flexible.

This application is a divisional of Canadian Patent Application No. 2,023,132-7, filed August 10, 1990.

The embodiments of the invention in which an exclusive property or privilege is claimed are defined as follows:

1. Vertically raisable curtain door of the type comprising a flexible curtain having horizontal reinforcing bars disposed at regular intervals, and a drive unit including a winding shaft, wherein, at a bottom of the curtain, a small additional piece of curtain is provided with a flexible reinforcing bar for serving as a ballast or as a feeler bar.
2. Vertically raisable curtain door which is foldable concertina-like, the door being of the type comprising a flexible curtain having horizontal reinforcing bars disposed at regular intervals, lifting straps fixed to a bottom-bar and passing through guide rings fixed to at least some of the bars, and a drive unit including a strap winding shaft, wherein, at a bottom of the curtain, a small additional piece of curtain is provided with a flexible reinforcing bar that is not connected to the lifting straps for serving as a ballast or as a feeler bar.
3. Curtain door as defined in one of claims 1 or 2, wherein the flexible reinforcing bar is constituted by a coil spring.

4. A goods-handling door comprising:
  - two vertical lateral uprights, each of them having a vertical slideway;
  - a raisable flexible curtain having a bottom edge;
    - curtain lifting means including an electric motor for lifting said curtain in order to leave way to a person or a goods-handling vehicle;
    - a plurality of horizontal reinforcing bars, each of said bars being fixed to said curtain;
    - each of said reinforcing bar having two ends which slide in said slideways, said plurality of reinforcing bars including intermediate reinforcing bars and a lowermost reinforcing bar disposed at a distance above said bottom edge of said curtain; and
    - an additional, flexible bar, disposed at said bottom edge of said curtain so that a shock received at the bottom edge of the curtain will not injure a person or damage a goods-handling vehicle.
5. The goods-handling door according to Claim 4, wherein said flexible bar includes a coil spring.
6. The goods-handling door according to Claim 4, wherein said curtain lifting means further include a horizontal winding shaft actuated by said electric motor and disposed above the curtain, for winding up said curtain around said winding shaft.
7. The goods-handling door according to Claim 4, wherein said curtain lifting means further include vertical belts and a horizontal winding shaft for winding said belts, said horizontal winding shaft being disposed above said curtain and actuated by said electric motor, said belts being attached to said lowermost reinforcing bar and passing slidably

by said intermediate reinforcing bars, such that the curtain is folded concertina-like when said belts are wound up around said belts are wound up around said winding shaft.

FIG. 1

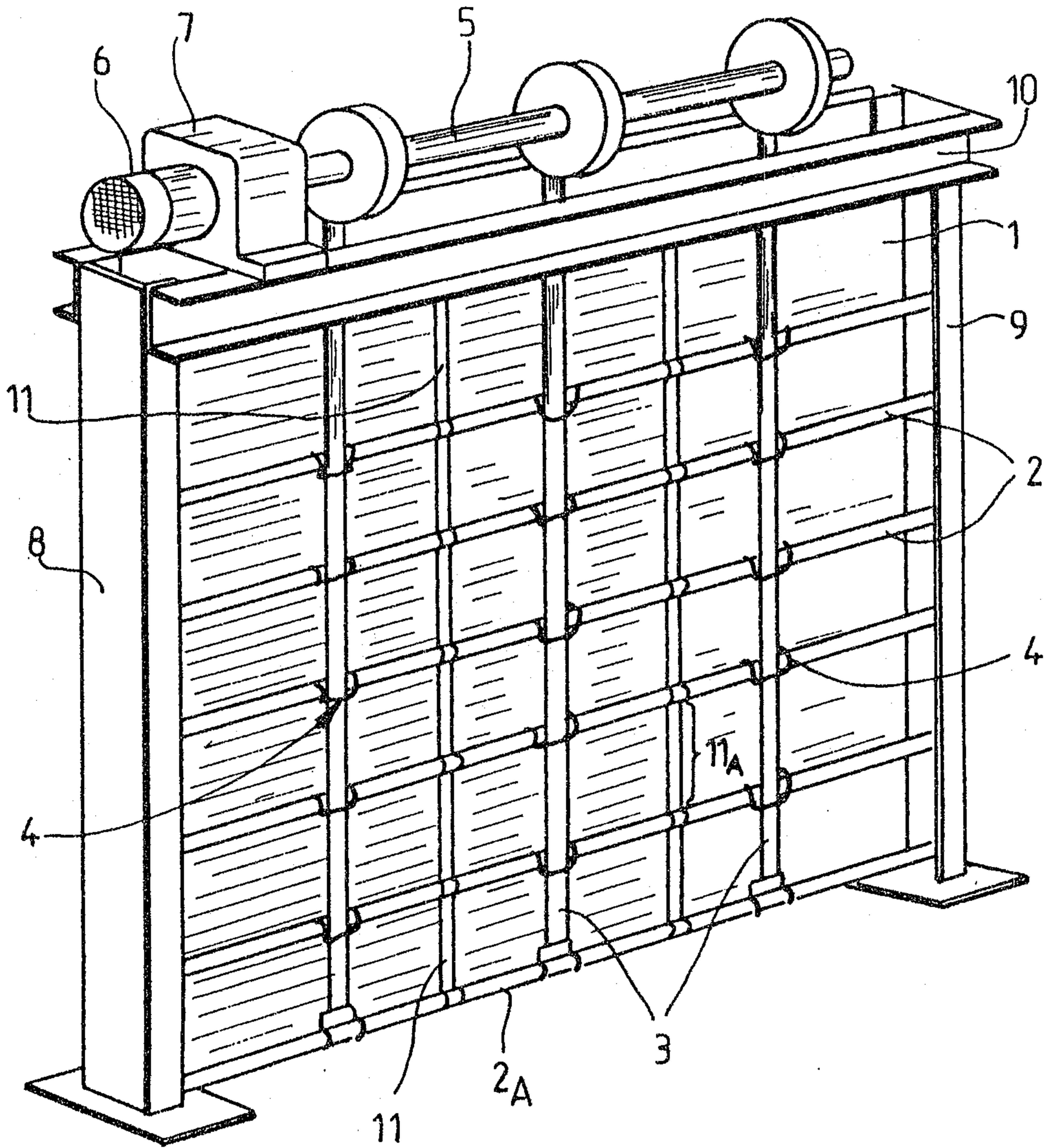

PATENT AGENTS

*Dwight Ogilby Renault*

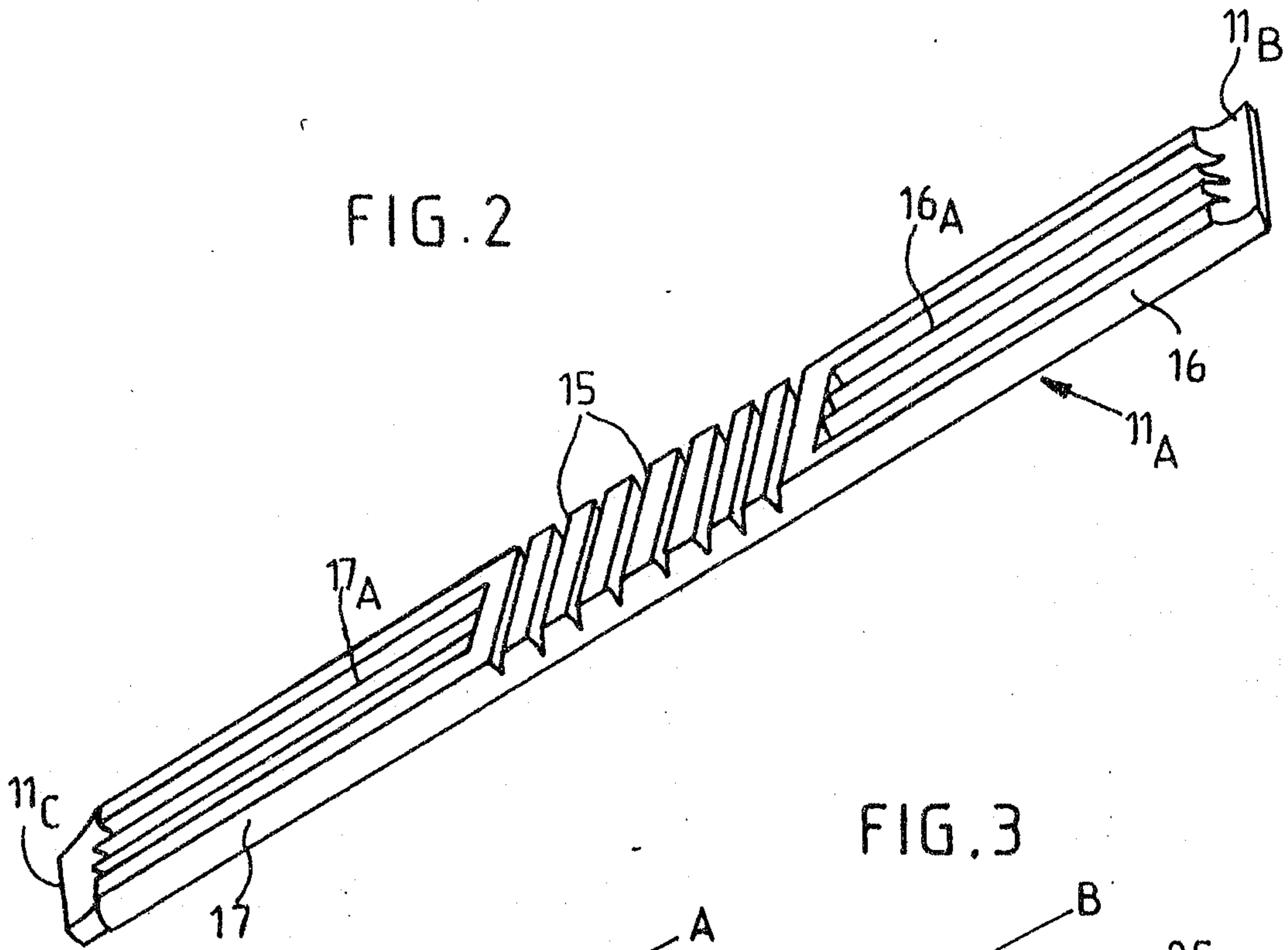

FIG. 2

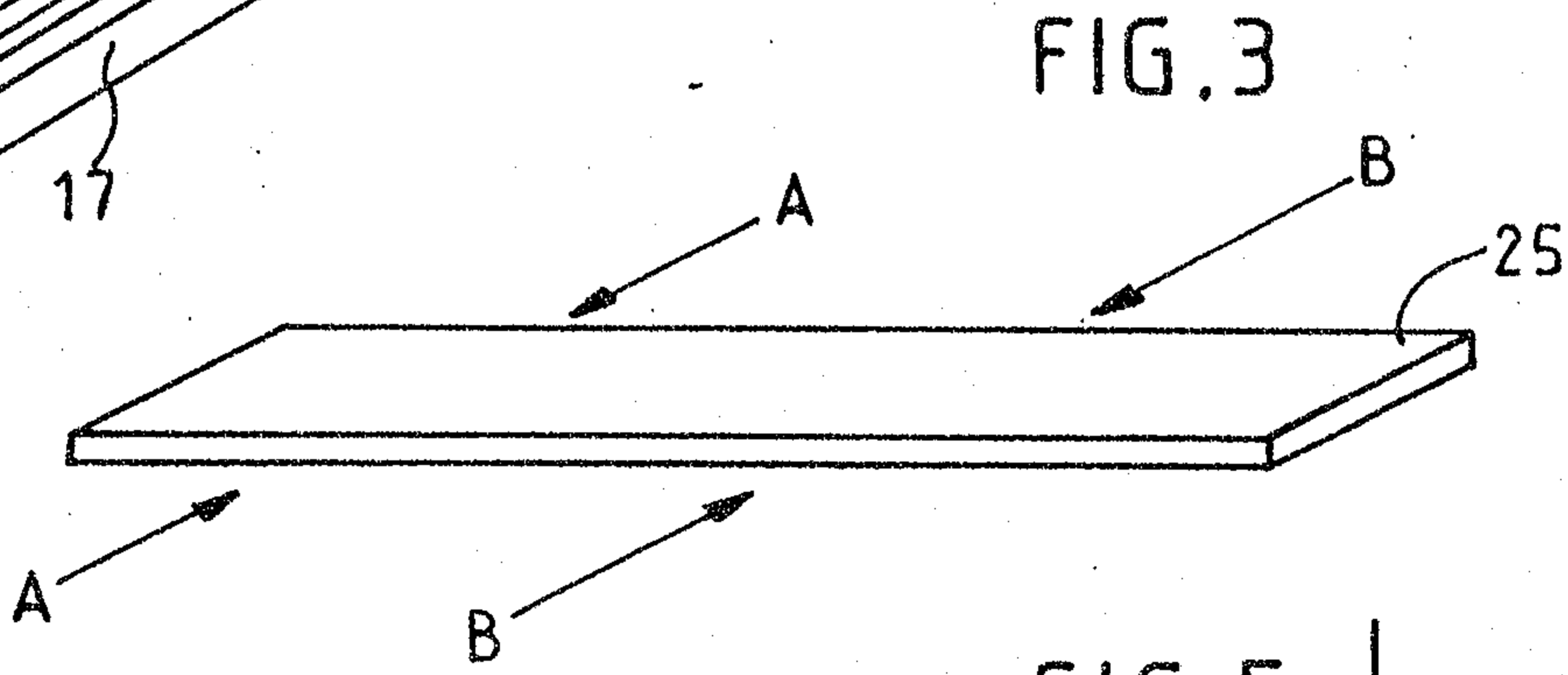

FIG. 3

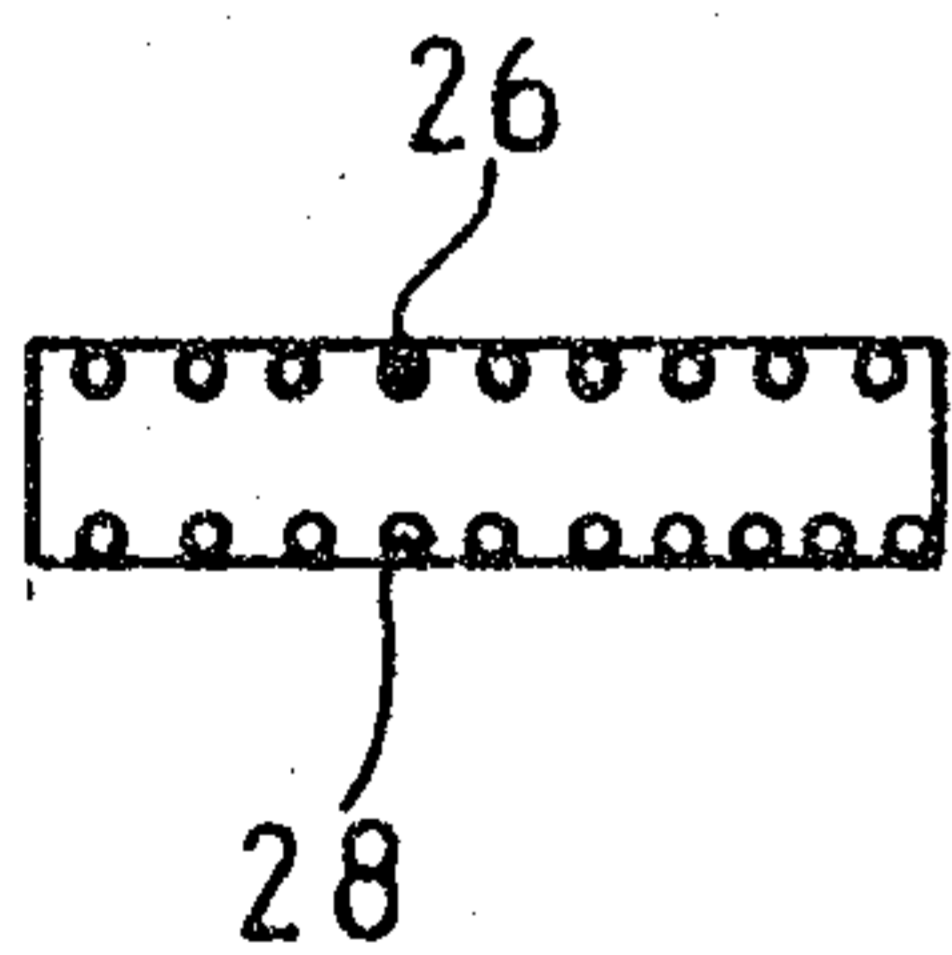

FIG. 4A

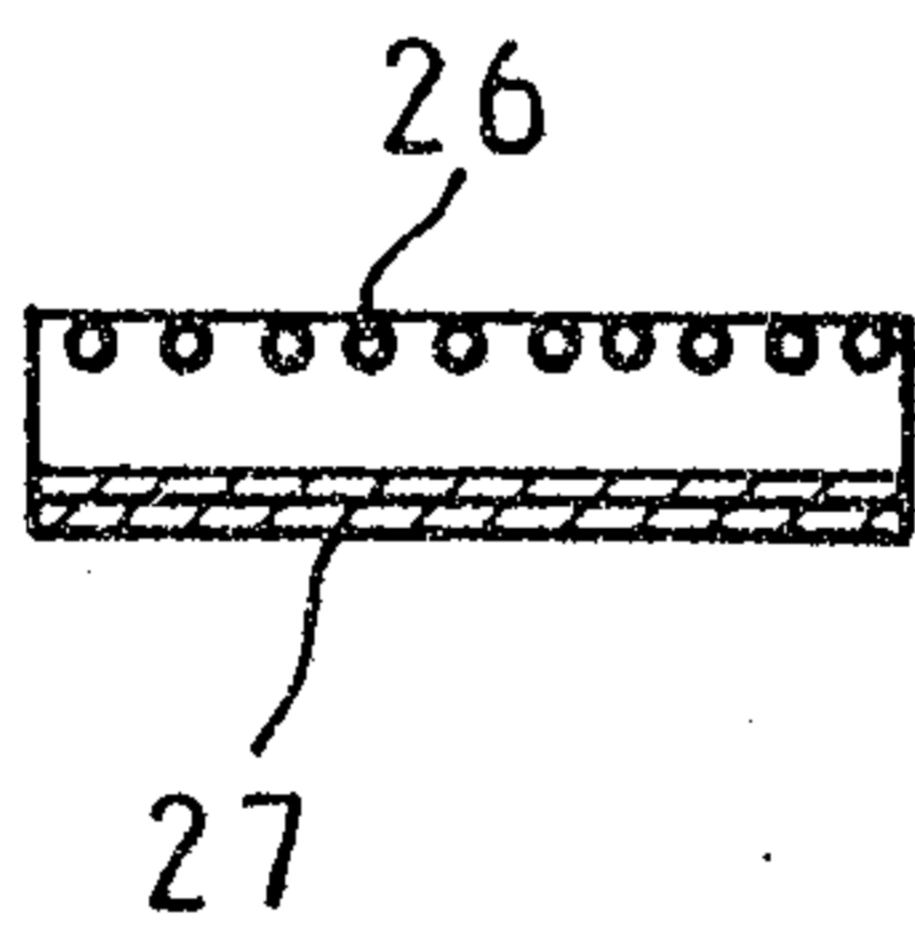

FIG. 4B

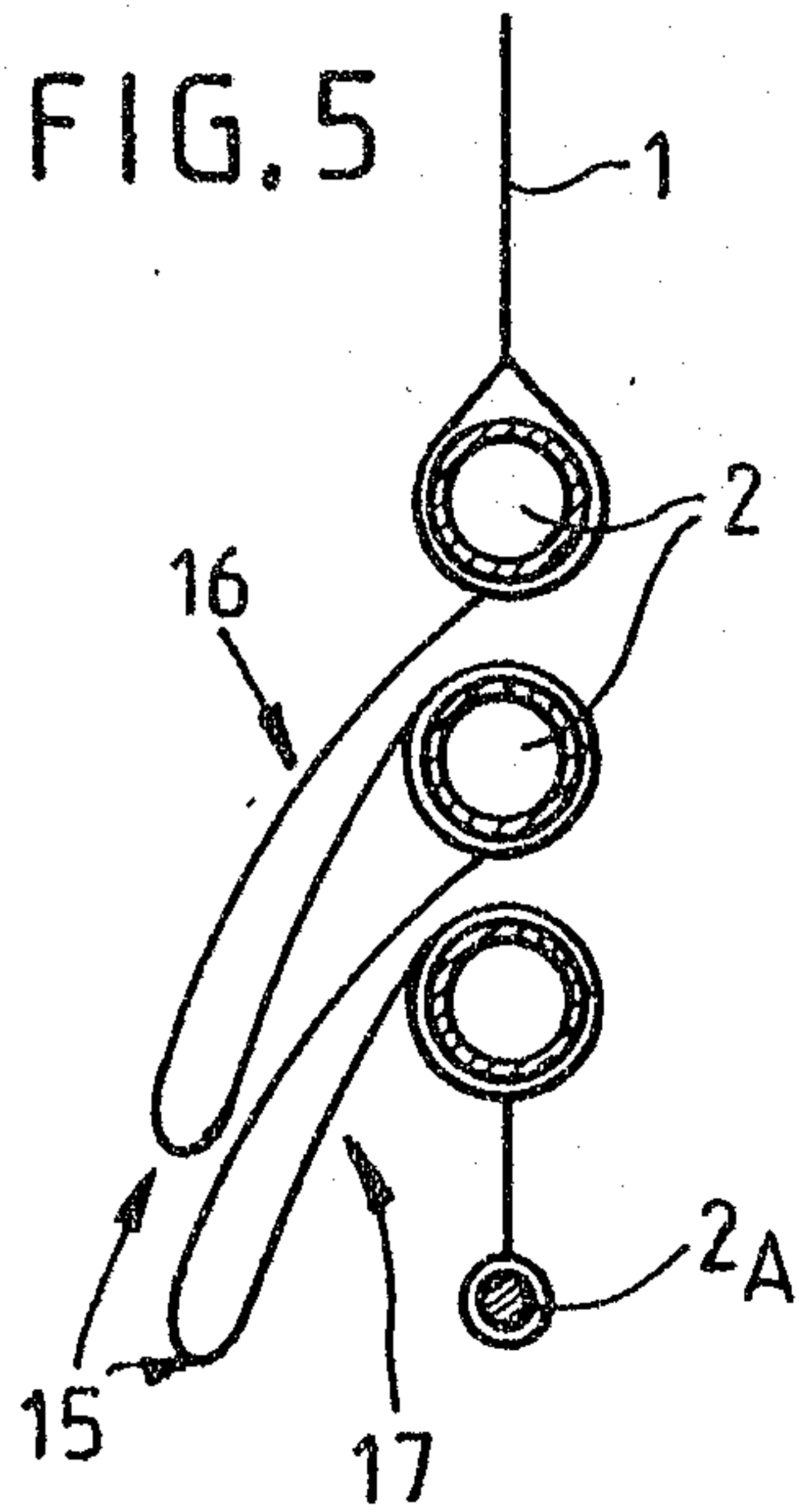

FIG. 5

PATENT AGENTS

*Swasey Ogilvy Renault*

