

(No Model.)

D. DUNNE.

BED FOR CRUSHING ROLLS.

No. 344,258.

Patented June 22, 1886.

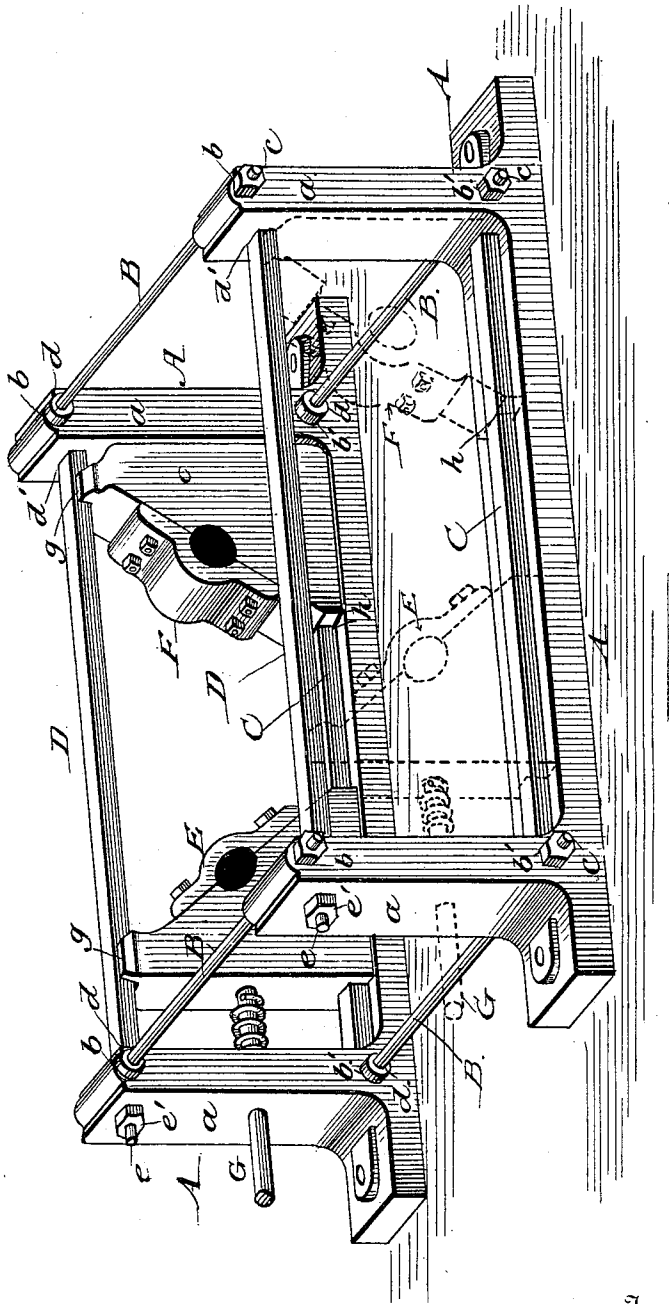

Witnesses

J. W. Fowler
H. B. Applenhardt

Inventor

Daniel Dunne

By his Attorneys.

A. H. Evans & Co.

UNITED STATES PATENT OFFICE.

DANIEL DUNNE, OF SALT LAKE CITY, UTAH TERRITORY, ASSIGNOR TO
ENOS A. WALL, OF SAME PLACE.

BED FOR CRUSHING-ROLLS.

SPECIFICATION forming part of Letters Patent No. 344,258, dated June 22, 1886.

Application filed December 26, 1885. Serial No. 186,777. (No model.)

To all whom it may concern:

Be it known that I, DANIEL DUNNE, a citizen of the United States, residing at Salt Lake City, in the county of Salt Lake and Territory of Utah, have invented certain Improvements in Beds for Crushing-Rolls, of which the following is a full, clear, and exact description, reference being had to the accompanying drawing, forming part of this specification, in which the figure represents a perspective view of my improvement, the crushing-rolls being removed, and showing the bearing-boxes for the same.

My invention relates to the construction of the beds, main frames, or castings of crushing-machines; and the same consists in the construction and combination of devices herein-after fully described and specifically claimed.

To enable others skilled in the art to which my improvement appertains to make and use the same, I will now describe its construction and operation.

The main casting or bed employed in many of the crushing-machines of the present day is of such a nature that the breaking or twisting of either of the main shafts, or the dislocation or working loose of certain of the elements comprising the machine, will often necessitate the taking apart of nearly the whole machine, thereby entailing great loss of labor and time in the rearrangement or setting up of the machine.

The improvements hereinafter described are designed to obviate to a great extent this delay and inconvenience, and at the same time provide a bed whereby the simple removing of two bolts will readily permit any of the working parts of the device to be removed in case of necessity and replaced with new pieces.

In the said drawing, the main casting or bed therein shown comprises two side pieces, A, of uniform size and construction, and adapted to support the journal-boxes and other portions of the machine. These side pieces, A, are provided with standards *a*, through the upper portions of which openings, *b*, are bored transversely, similar openings *b'* being bored through the lower portions of the side pieces and in line with the upper openings, *b*. Suit-

able bolts, B, pass through the perforations *b* and *b'*, and securely unite the two sides A of the bed together through the medium of nuts and washers *c* and *d*, as shown, thus forming a rigid bed for the adjustment and support of the crushing-rolls.

On the upper surfaces of, and formed integral with, the main portions of the side pieces, A, between the standards *a*, are raised ribs or projections C, which form the lower guides for the sliding journal-boxes. The upper portions of the standards *a* have square openings *d'*, formed therein at right angles to the openings *b*, which are adapted to sustain the upper guides, D, the said guides consisting of square or round bars with reduced threaded ends *e*, which project through the openings and are secured by nuts *e'*, as shown. The journal-boxes E and F, which support the shafts of the crushing-rolls, are located between the guides C and D, and are of ordinary construction, except that their upper portions are provided with lips *g*, which partially encircle the guides D and prevent lateral movement or displacement, while the under surfaces of the boxes are provided with grooves *h*, corresponding in size and formation to the lower guides or projections, C. From this description it is evident the boxes E and F have a free longitudinal movement upon the guides, the boxes E being the movable ones, or the boxes for adjusting the distance between the crushing-rolls, they being provided with the usual spring-rods, G, passing through the standards *a* and forming yielding bearings for the adjustable crushing-roll.

The arrangement of the guides D, as previously described, permits one or both the said guides to be readily withdrawn through the openings *d'* by removing the nuts *e'*, thereby permitting either or both the crushing-rolls to be removed from the machine without affecting the other portions of the same. Under the construction and arrangement of parts described the machine can be taken apart and packed in a comparatively small space. At the same time it may be readily set up without the assistance of a skilled mechanic.

Having thus described my invention, what

I claim as new, and desire to secure by Letters Patent, is—

The journal-boxes E and F, provided with lips *g* and grooves *h*, in combination with stationary side pieces having ribs or guides, removable guide-bars, securing-bolts mounted in the upper and lower portions of said side

pieces, and the nuts for securing the guide-bars and bolts, substantially as described.

DANIEL DUNNE.

Witnesses:

G. B. WHITECAR,
W. H. FOWLER.