

Feb. 1, 1966

I. S. DE WOSKIN

3,232,293

PANTY WITH SANITARY NAPKIN SUPPORTING MEANS

Filed Jan. 26, 1965

2 Sheets-Sheet 1

FIG. 1.

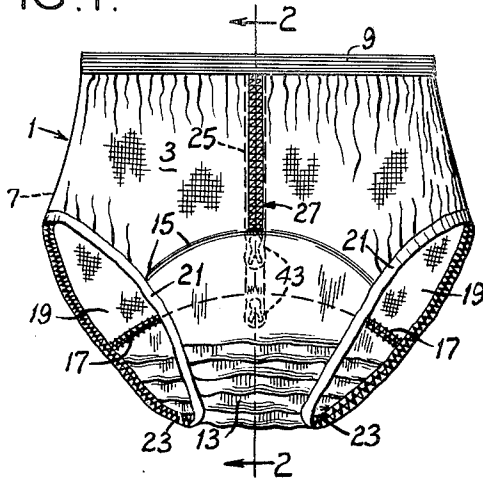

FIG. 2.

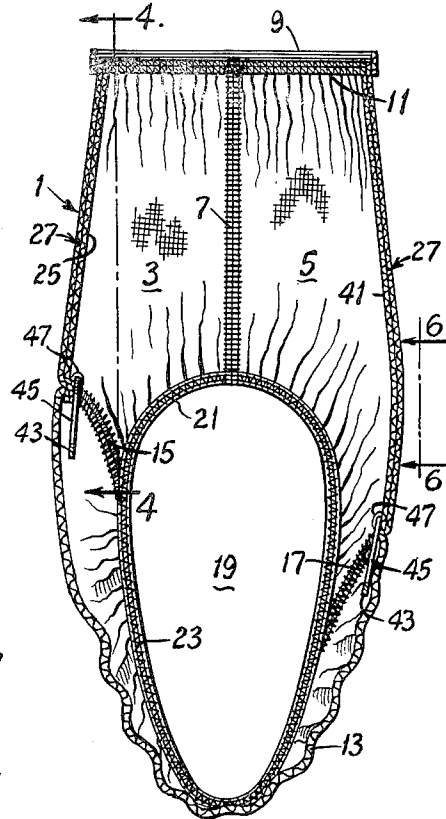

FIG. 3.

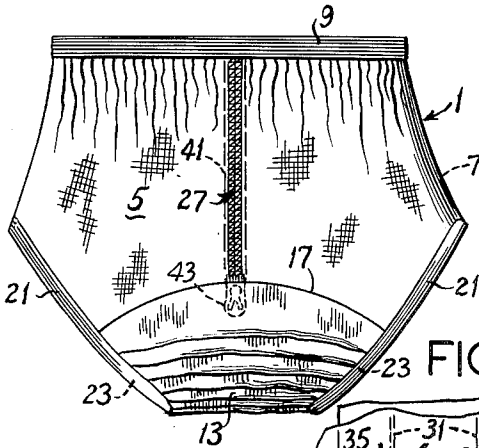

FIG. 6.

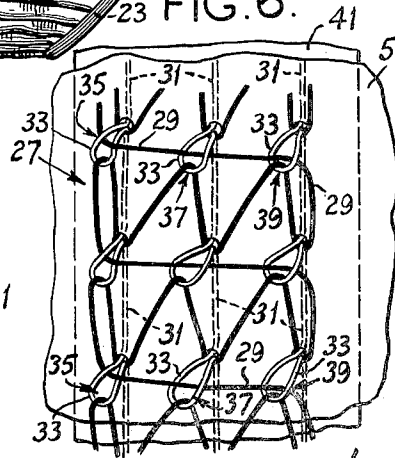

FIG. 5.

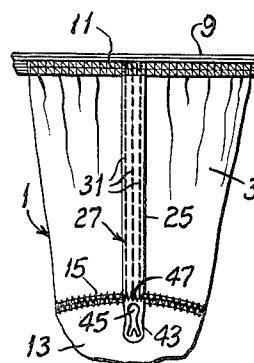
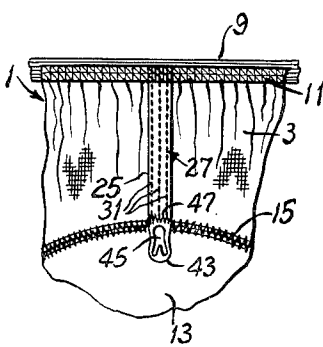

FIG. 4.



Irwin S. De Woskin,
 Inventor.
 Koenig, Pope, Senniger and Powers,
 Attorneys.

Feb. 1, 1966

I. S. DE WOSKIN

3,232,293

PANTY WITH SANITARY NAPKIN SUPPORTING MEANS

Filed Jan. 26, 1965

2 Sheets-Sheet 2

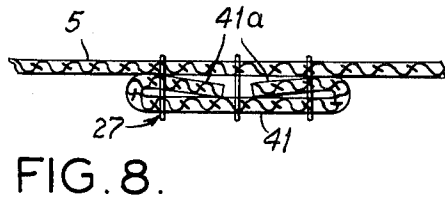
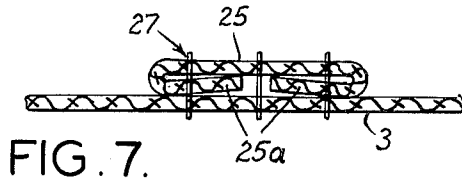

1

2

3,232,293

**PANTY WITH SANITARY NAPKIN
SUPPORTING MEANS**

Irvin S. De Woskin, St. Louis, Mo., assignor to Beltx Corporation, St. Louis, Mo., a corporation of Missouri
Filed Jan. 26, 1965, Ser. No. 432,058
10 Claims. (Cl. 128-288)

This application is a continuation-in-part of my copending United States patent application for Sanitary Garment, Serial No. 254,011, filed January 25, 1953, and now abandoned. This invention relates to a sanitary garment, and more particularly to a sanitary garment of the so-called panty type for wear with a sanitary napkin, being an improvement upon the garment shown in my United States Patent 2,678,648.

Among the several objects of this invention may be noted the provision of an improved sanitary garment of the panty type for more snugly holding in place a sanitary napkin, the garment being at the same time adapted better to fit women having widely different waist or hip sizes; the provision of a sanitary garment in which various portions of the garment stretch uniformly, thereby balancing strains on portions of the garment when it is stretched; and the provision of a sanitary garment of this class which is economical to manufacture. Other objects and features will be in part apparent and in part pointed out hereinafter.

The invention accordingly comprises the constructions hereinafter described, the scope of the invention being indicated in the following claims.

In the accompanying drawings, in which one of various possible embodiments of the invention is illustrated,

FIG. 1 is a front elevation of a sanitary garment made according to the invention;

FIG. 2 is an enlarged section taken substantially on line 2-2 of FIG. 1;

FIG. 3 is a rear elevation of FIG. 1;

FIG. 4 is a fragmentary section taken substantially on line 4-4 of FIG. 2 but on the scale of FIG. 1;

FIG. 5 is a fragmentary section similar to FIG. 4 and on the same scale as FIG. 4, showing certain material in a stretched condition;

FIG. 6 is an enlarged detail face view of a section of a seam viewed from line 6-6 of FIG. 2; and

FIGS. 7 and 8 are enlarged fragmentary detail sections.

Corresponding reference characters indicate corresponding parts throughout the several views of the drawings.

Referring to the drawings, a sanitary panty garment of my invention is shown to comprise an integral body portion 1 of thin elastic fabric material. The body portion 1 forms front and back sections or panels 3 and 5, respectively. These sections may be formed from a single piece of fabric and have one stitched side seam 7 as shown or the sections may be separately formed and secured by two side seams. The body portion 1 is composed of material having substantial stretch in all directions, such as commercially available crimped nylon or a combination of stretch nylon and acetate, for example. An elastic waistband 9 encircles to waist of the body portion and is shirred thereto by the generally zigzag seam indicated at 11. At numeral 13 is shown a one-piece crotch section of flexible, impervious, waterproof material. A suitable commercially available material for section 13 is rayon coated with a plastic on a side which is to become its inside in the garment. Such material is usually substantially non-stretchable per se. The section 13 by stitching along its front and back margins 15 and 17 is attached to the front and back body sections 3 and 5 respectively. The body portion 1 and crotch section 13 are cut to provide leg openings 19. Elastic bands 21 encircle the leg openings, being stitched in a generally zigzag manner to the margins

of the body portion and the side margins of the crotch section which extend along the leg openings as indicated at 23. This stitching shirrs the bands 21 to the otherwise comparatively inelastic crotch section 13 so as to render its margins stretchable. The front and back margins 15 and 17 of the crotch section extend from one leg opening to the other.

On the inside of the front section of the body portion is a narrow stretchable fabric tape 25 extending generally centrally from the waistband 9 to and terminating at the center of the front margin of the crotch section and caught at its upper end in the waistband seam 11 and at its lower end in the front crotch section seam 15. The tape 25 is stitched to the front body section in a general zigzag manner as indicated at 27 (FIG. 6). Stitching 27 is formed by a thread 29 extending transversely of the tape 25 in one direction on the outside of the garment and then transversely back in a serpentine-shaped path. This stitching configuration is repeated throughout the length of the tape. Three row of additional stitching 31 extend longitudinally along the tape 25 on the inside of the garment and have loops 33 extending through the tape and the garment at appropriate intervals. The loops 33 encircle the thread 29 as indicated at 35, 37 and 39. This form of stitching permits the stretchable tape and the stretchable front body section 3 to be stretched in the direction of the length of the tape without rupturing the stitching 27. The stitching 27, which is both stretchable and contractable, may be referred to as an elastic stitching. On the inside of the back section 5 of the body portion is another stretchable fabric tape 41 (like tape 25) extending centrally from the rear of the waistband 9 to and terminating at the center of the back margin 17 of the crotch section. This is caught at its upper end in the waistband seam 11 and at its lower end in the back crotch seam 17. The tape 41 is stitched to the back body section in the same manner as tape 25, so that the back body section and tape may be stretched in the direction of the tape without rupturing the stitching 27. It will be appreciated that the stretching ability of the front and rear sections 3 and 5 along tapes 25 and 41 is in addition to their stretching abilities in a girthwise direction. This result is due to the universal stretching ability in all directions of the crimped nylon or similar material constituting the body portion 1.

Attached to each tape 25 and 41 at its lower end and interiorly of the garment is a sanitary napkin fastener 43 of any suitable type, but preferably of the type shown in U.S. Patent D. 144,290. Such a fastener 43 has an end opening 45 for receiving stitching 47 attaching it to the tape just above the seam 15 or 17 as the case may be. The fasteners extend over the ends of the crotch section.

A fragment of the garment is shown in FIG. 4 in unstretched condition. It is illustrated in a stretched condition in FIG. 5. It will be seen that the tape 25 and the adjacent body portion 1 are longer than their FIG. 4 condition, but that the stitching 27 is not ruptured. Rather the stitching is elongated.

It will be understood that the stitching 11 and 23 may be of the elastic type similar to stitching 27.

Each of the tapes 25 and 41 preferably consists of a strip of the same stretchable fabric as is used for the body portion 1 of the garment, e.g., crimped nylon fabric or a combination of stretch nylon and acetate. It will be understood, however, that the tapes may be made of a different material than that of the body portion of the garment as long as they have the same or substantially the same stretch characteristic as that of the material of the body portion of the garment. As shown in FIG. 7, the tape or strip 25 has side margins 25a folded over on one face thereof to form hems which are disposed against

the inside surface of the front panel 3, and as shown in FIG. 8, the tape or strip 41 has side margins 41a folded over on one face thereof to form hems which are disposed against the inside surface of the back panel 5.

In use, a sanitary napkin (not shown in the drawings) is gripped at its ends by the fasteners 43 in position on the inside of the protective impervious crotch section 13. One size of the garment fits women of various physiques due to the universal elasticity of the body portion 1 and the stretchability of the tapes 25 and 41 and of the stitching connecting the tapes to the body portion. Thus the garment fits the hips snugly and the napkin is drawn up snugly in the crotch. With tapes 25 and 41 made of the same stretch fabric as the body portion of the garment, or made of material having the same stretch characteristic as the material of the body portion of the garment, they stretch uniformly with the body portion, avoiding puckering of the garment, strain transmitted from the napkin to the fasteners being balanced between the tapes 25 and 41 and the yielding fabric of the body portion of the garment, and being transmitted to the waistband 9 via the securement of the upper ends of the tapes in the waistband seam 11. The fabric of the body portion of the garment, while being stretchable to fit the woman wearing the garment, is relieved of strain resulting from the attachment of a napkin. Use of tapes made from the same stretch material as the body of the garment is preferable to use of conventional elastic tape, the latter having a tendency to cause puckering of the body of the garment if elasticity is relatively high, or, if its elasticity is relatively low, tending to concentrate strain on the material of the body portion. The securement of the napkin fasteners to the tapes rather than to the elastic fabric of the garment results in a strong attachment precluding ripping out of the fasteners. Moreover, the ends of the tapes 25 and 41 are caught by seams attaching margins 15 and 17 respectively and thus reinforce these seams between the crotch section and the body section to preclude ripping thereof.

In view of the above, it will be seen that the several objects of the invention are achieved and other advantageous results attained.

As various changes could be made in the above constructions without departing from the scope of the invention, it is intended that all matter contained in the above description or shown in the accompanying drawings shall be interpreted as illustrative and not in a limiting sense.

What is claimed is:

1. A sanitary panty garment comprising a body portion forming front and back sections, said body portion being composed of material which is substantially stretchable in all directions, an elastic waistband encircling an upper end portion of the garment and attached thereto, a crotch section attached to the lower portions of the front and back sections respectively, said front and back sections and the crotch section having margins adapted to form leg openings, lengths of stretchable tape extending downward from said waistband on the front and back sections respectively to the front and rear portions of the crotch sections, said lengths of tape being composed of material having substantially the same stretch characteristic as the body portion of the garment, each length of the tape being attached to said stretchable material of the body portion by a seam which is stretchable along the length of its respective tape.

2. A garment according to claim 1, wherein the opposite ends of said tapes are caught by said waistband and by seams which attach the crotch section to the front and back sections, and napkin fasteners attached to said tapes above the points wherein the tapes are caught by said last-named seams.

3. A garment according to claim 1, wherein the lengths of tape have side margins folded over onto one face of the tapes to form hems which are disposed against the

body portion and which are caught in said stretchable seam.

4. A garment according to claim 1, wherein said crotch section is composed of comparatively inelastic material, and wherein the ends of said tape at the crotch section are caught by said seams which attach the crotch section to the front and back sections, napkin fasteners attached to said tapes above the points wherein they are caught by said last-named seams, and elastic bands attached by stitching around said leg openings and being shirred with the crotch section to render its sides stretchable.

5. A garment according to claim 4, wherein the attachment between the waistband and the body portion is by a shirred seam.

6. A sanitary panty garment having a body portion of elastic fabric and a crotch section of impervious material, a waistband seamed to the body portion, an elastic fabric tape on the inside of the front of the body portion caught at its upper end in the waistband seam and extending to the crotch section, an elastic fabric tape on the inside of the back of the body portion caught at its upper end in the waistband seam and extending to the crotch section, the tapes being seamed by stitching to the body portion in such manner as to permit stretching of the tapes and body portion in the direction of the lengths of the tapes, said tapes and body portion being composed of the same elastic fabric material, and sanitary napkin fasteners attached to the tapes at their lower ends for holding a sanitary napkin in place in the crotch section.

7. A sanitary panty garment having a body portion of elastic fabric material and a crotch section of impervious material seamed along the front and back margins thereof to the body portion, a waistband seamed to the body portion, a narrow elastic fabric tape on the inside of the front of the body portion caught at its upper end in the waistband seam and extending to the front crotch section seam, a narrow elastic fabric tape on the inside of the back of the body portion caught at its upper end in the waistband seam and extending to the back crotch section seam, the tapes being seamed by stitching to the body portion in such manner as to permit stretching of the tapes and body portion in the direction of the lengths of the tapes, said tapes being composed of the same elastic fabric material as the body portion of the garment, and sanitary napkin fasteners attached to the tapes at their lower ends for holding a sanitary napkin in place in the crotch section.

8. A sanitary panty garment having a body portion of elastic fabric material and a crotch section of impervious material seamed along the front and back margins thereof to the body portion, a waistband seamed to the body portion, a narrow elastic fabric tape on the inside of the front of the body portion caught at its upper end in the waistband seam and at its lower end in the front crotch section seam, a narrow elastic fabric tape on the inside of the back of the body portion caught at its upper end in the waistband seam and at its lower end in the back crotch section seam, the tapes being seamed by stitching to the body portion in such manner as to permit stretching of the tapes and body portion in the direction of the lengths of the tapes, said tapes being composed of the same elastic fabric material as the body portion of the garment, and sanitary napkin fasteners attached to the tapes at their lower ends for holding a sanitary napkin in place in the crotch section.

9. A sanitary panty garment having a one-piece body portion of thin elastic fabric material, said body portion having front and back sections joined at a stitched side seam, and a crotch section of impervious material seamed by stitching along the front and back margins thereof to the body portion, an elastic waistband seamed by stitching to the body portion, a narrow elastic fabric tape on the inside of the front section of the body portion extending generally centrally from the waist of the garment to the crotch section and caught at its upper end in the

5

stitched waistband seam and at its lower end in the stitched front crotch section seam, a narrow elastic fabric tape on the inside of the back section of the body portion extending generally centrally from the waist of the garment to the crotch section and caught at its upper end in the stitched waistband seam and at its lower end in the stitched back crotch section seam, the tapes being stitched along their margins to the body portion throughout their length in such manner as to permit stretching of the tapes and body portion in the direction of the lengths of the tapes, said tapes being composed of the same elastic fabric material as the body portion of the garment, and sanitary napkin fasteners attached by stitching to the tapes at their lower ends just above the crotch section seams and extending over the ends of the crotch section for holding a sanitary napkin in place in the crotch section.

10. A garment according to claim 9, wherein the tapes have side margins folded over onto one face of the tapes

6

throughout their lengths to form hems which are disposed against the body portion and which are caught in the stitching securing the tapes to the body portion.

References Cited by the Examiner

UNITED STATES PATENTS

1,729,265	9/1929	George	128—288
2,134,925	11/1938	Nichols et al.	128—288
2,252,992	8/1941	Steiner	128—288
2,675,806	4/1954	Bram	128—288
2,678,648	5/1954	De Woskin	128—288
2,706,389	4/1955	Garrou et al.	
3,038,474	6/1962	Harwood et al.	128—288

FOREIGN PATENTS

77,306 3/1954 Netherlands.

RICHARD A. GAUDET, *Primary Examiner.*