

June 29, 1937.

E. KINSELLA

2,085,532

PRODUCTION OF ARTIFICIAL MATERIALS AND APPARATUS THEREFOR

Filed Jan. 11, 1933

2 Sheets-Sheet 1

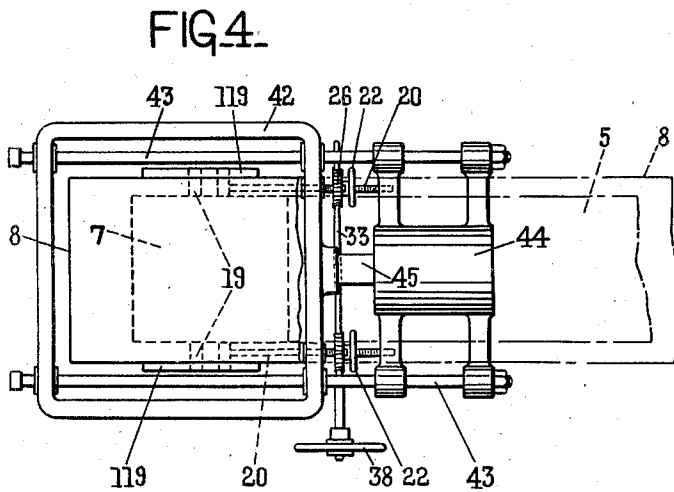
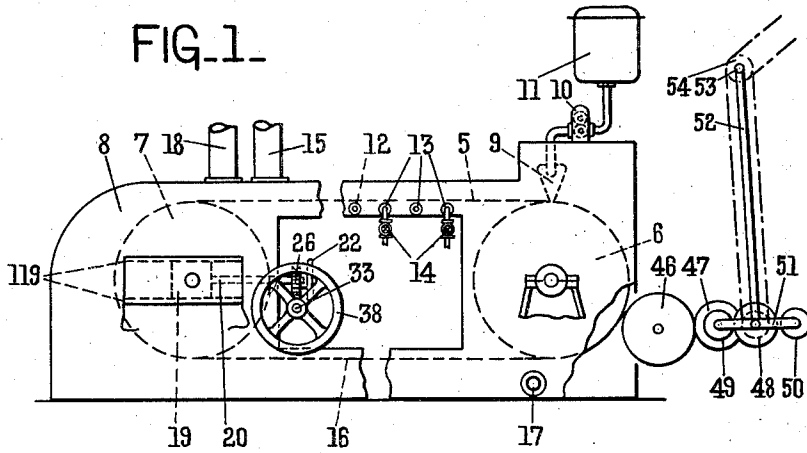

EDWARD KINSELLA
INVENTOR

J. H. Kelly & C. W. Brown
ATTORNEYS

June 29, 1937.

E. KINSELLA

2,085,532

PRODUCTION OF ARTIFICIAL MATERIALS AND APPARATUS THEREFOR

Filed Jan. 11, 1933

2 Sheets-Sheet 2

FIG. 2-

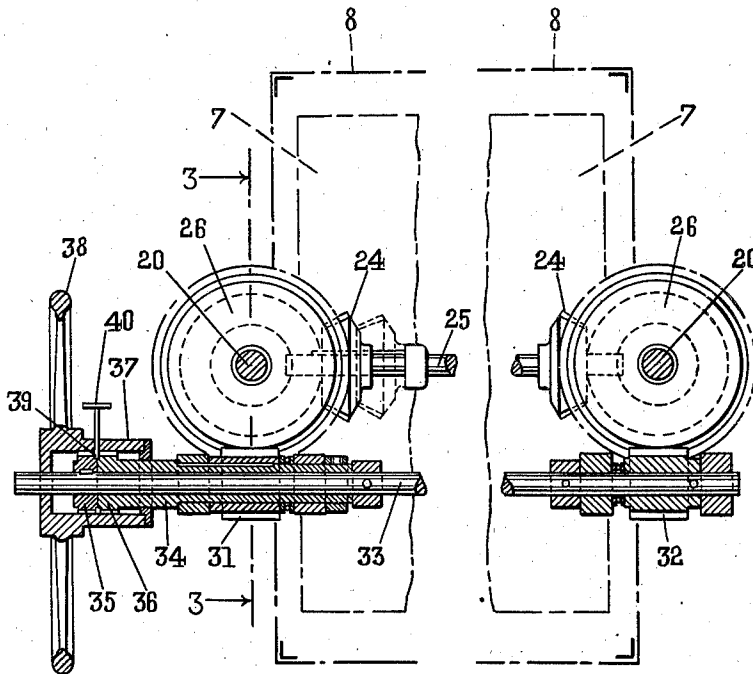
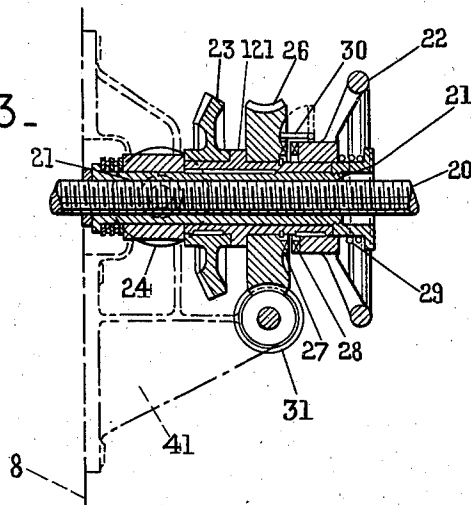

FIG. 3-



EDWARD KINSELLA
INVENTOR

J. Seltzer & C. W. Bourne
ATTORNEYS

UNITED STATES PATENT OFFICE

2,085,532

PRODUCTION OF ARTIFICIAL MATERIALS AND APPARATUS THEREFOR

Edward Kinsella, Spondon, near Derby, England,
assignor to Celanese Corporation of America,
a corporation of Delaware

Application January 11, 1933, Serial No. 651,159
In Great Britain January 30, 1932

2 Claims. (Cl. 18—15)

This invention relates to the manufacture of artificial materials, and in particular to the manufacture of artificial films or foils, especially of thin foils suitable for use as wrapping paper, electrical insulation or other purposes.

The manufacture of such foils is effected by depositing a thin layer of a solution of the base material of the foil in any suitable solvent liquid on to a smooth surface, causing the thin layer to set and thereafter stripping the foil from the surface. Setting of the solution may be effected either by evaporation or by coagulation, the former usually being resorted to where the base material of the foil consists of cellulose acetate, cellulose nitrate or other derivatives of cellulose such as other esters of cellulose or cellulose ethers, and the latter, the wet method, being usually employed where the foil is of a cellulosic character, in which case the solution is generally in the form of viscose.

The smooth surface on to which the layer of solution is deposited is generally either in the form of a wheel or drum or an endless metal, paper, or other band, the drum or band moving continuously through the setting medium so that production of the foil forms a continuous operation. The layer is deposited on the moving surface at any point in its path, and is carried thereby through the setting medium to the point at which stripping takes place, generally near to the depositing point so as to use to the full the length or periphery of the surface as a setting run.

It will be readily understood that apart from the manner in which the layer is deposited on the smooth surface, the quality of the product, and in particular its appearance, depends to a very large extent upon the nature of the surface itself. For instance, it is generally desirable, particularly where the foil is intended for use as a wrapping material, in which case transparency is usually regarded as important, to produce a material whose surface is as smooth and even as possible so as to impart a fine glossy appearance to the product. Since, however, one face of the foil is formed in intimate contact with the surface on which the solution has been deposited, this surface partakes exactly of the configuration of the surface, so that any irregularities found thereon are exactly reproduced. In the case of transparent foil in particular any such irregularities detract appreciably from the value of the foil. In addition, variations in the evenness of the surface may affect to some extent the thickness of the product which, apart from causing diminution in the strength of the material and its

permeability to moisture and requiring a greater weight of material than is necessary for the desired strength, etc., may also reduce its good appearance on account of the tendency to produce waves or cockles in the material.

A very convenient form of apparatus consists in an endless band having a suitably smooth glossy surface, since such band can easily be formed of any desirable length in accordance with the length of drying run required (this being a function of the nature of the material forming the film, the concentration and viscosity etc. of the solution, and the rate at which production is to take place), without increasing the complication and weight of the apparatus. The band thus enables the design of the apparatus to be flexible in character, long bands merely requiring simple addition to the length of the drying run.

The present invention is directed particularly to the use of this type of apparatus, and has for its object to provide a band which will produce the highest quality of film or foil and be serviceable in operation.

According to the invention, a metal band is used, the band itself having an exceedingly highly polished surface, so that the solution can be deposited directly upon the band. In order to ensure that the high polish of the surface is maintained, the metal of the band is such that it is capable of withstanding any corrosive influence for a considerable time; that is to say the band should be substantially unaffected by the spinning solution itself or atmospheric conditions in the case of the dry method of operation, and by the setting bath in the case of the wet method of operation. Further, (and this is of the greatest importance) the band must also be capable of being flexed repeatedly without deterioration in its passage from the apparatus in the cycle of operations involving deposition of the solution, drying of the film or foil, and stripping. Further, apart from being capable of receiving exceedingly high polish, the surface of the band should be sufficiently tough to resist wear to a very marked extent.

Accordingly, therefore, the metal of which the band is composed is of high elasticity, so that after being flexed, even after a very large number of times, it returns to its original form. In other words the band does not absorb any internal work performed on it by the act of flexing, or become stretched or strained, so that it maintains its smoothness of surface.

For this purpose stainless steel is particularly suitable not only by its intrinsic anti-corrosive

properties and capability for receiving and maintaining a very high gloss, but also because of its high elasticity, this being moreover considerably increased by the cold rolling necessary to produce a relatively thin and sufficiently flexible band of say 40 to 30 or 20 thousandths of an inch or less in thickness.

Another metal which, though not as tough as stainless steel, is very suitable is nickel which can be formed by cold-rolling into the form of bands of considerable flexibility and elasticity. The surface of bands made from this material is practically unaffected by any corrosive influences encountered in the manufacture of films or foils, so that its smoothness remains unimpaired for long periods, thus allowing the apparatus to continue in operation without the necessity for fairly frequent stoppages for renewal of the surfaces. Further, the particularly smooth finish which can be imparted to the stainless steel or nickel surface enables very highly glossed foils to be produced by deposition of solution directly on to the surfaces and avoids the necessity for applying coatings of gelatin or like material to receive the solution.

Repeated stripping of film or foil over long periods tends to exert a wearing or abrading action on the depositing surface. In the case of stainless steel its toughness resists such action to a very high degree, so that even particularly highly polished surfaces are very little affected if at all, while the relatively softer nickel is also very serviceable in this respect because of the toughness which can be imparted in rolling nickel into a thin band.

A further advantage resides in the fact that even if the surface deteriorates to any small extent for any reason after being in use for some time it can readily be re-polished to its original smoothness. Moreover, since any pitting which may take place can only do so to an extremely small depth, it is possible to use the stainless steel or nickel as a comparatively thin band which is yet capable of being re-polished repeatedly, and so has a very considerable life.

As has already been indicated, the quality of the films or foils produced depends to a very large degree upon the smoothness of the depositing surface, and it is here emphasized that exceedingly great care must be observed in finishing the bands to ensure that despite apparent high polish no minute scratches of any description can be found in the surface. In fact, the surface should be given a mirror polish and very great care should be taken in operating the band to ensure that no damage is done to the surface. When necessary, especially if the band has been in operation for some time, re-polishing may be resorted to.

Any joint in the band must be very carefully finished, not only to ensure that the surface smoothness of the band is unbroken but that the band remains resistant to corrosion at the joint. If in the formation of the joint heat treatment, e. g. welding, is used which may have affected the toughness or resistance of the metal, suitable treatment such as cold rolling should be applied to the joint before its final smoothing and polishing.

The following indicates the general steps to be followed in the production of a nickel band for the purpose of the invention. A band of suitable length, width, and thickness is thoroughly annealed, and its ends are perfectly cleaned in readiness for jointing. This is effected by

hammer-welding in a reducing atmosphere at a relatively low temperature (say 200° C. below the melting point). It is preferred that the joint be made in this way, since it avoids the danger of warping which is present if higher temperatures are employed for the purpose, and the difficulty of subsequently eliminating the warping.

The welded band is then subjected to a cold-rolling process which brings it to the desired final thickness, this operation being carried out carefully to leave the band as straight as possible. At the same time, the working makes the metal at the joint substantially identical in structure to that in the rest of the band, and imparts a high degree of elasticity to the band, as well as hardening it and giving it a tough character.

Slight stretching may then be resorted to in order to make the band run true and straight, this being conveniently effected on a pair of drums which can be forced apart while rotating to subject the whole band to the stretching tension. Nickel bands produced in this way have not only a high degree of hardness (Brinell figure 114 or so) but also very considerable tensile strength (approximately 130,000 lbs.), and when finally polished are particularly suited as film or foil-forming surfaces.

The use of bands as above described enables machines of different capacities to be readily constructed, since it is quite a simple matter to obtain different lengths of drying run in accordance with the thickness or character of the foil or the speed of the machine without serious modification of the machine apart from the length.

Apparatus embodying the invention is illustrated in the accompanying drawings in which

Fig. 1 shows in side elevation a band machine having a pair of supporting drums giving the band two parallel setting runs;

Fig. 2 is a part sectional view showing details of the tensioning gear and its relation to one drum and the drum casing;

Fig. 3 is a section taken on the line 3—3 of Fig. 2; and

Fig. 4 is a part-sectional plan view of the movable drum machine with tension adjusting gear similar to that shown in Figs. 1 to 3, together with pressure means for automatic tension adjustment.

Fig. 1 shows a band 5 carried by drums 6, 7 within a casing 8. The band 5 may be, for example, .03 inch in thickness, and so of sufficient flexibility to pass round drums of quite small diameter; it is advisable, however, in order to reduce any possible adverse effect due to flexure of the band, to use drums of considerable diameter, e. g. 2-3 feet, and they may be even greater, e. g. 6 feet or more, if desired. The drums should, of course, be accurately machined and mounted to support and guide the band correctly. A solution of cellulose acetate in acetone is deposited on the band near the point where it reaches the top of the drum 6 by means of a box 9 supplied, for example, by means of a pump 10 from any suitable container 11. Pressure feed means such as the pump 10 are particularly desired with high concentration solutions, e. g. 33% acetone solutions, because of the high viscosity of such solutions.

The casing 8 is arranged to enclose the upper run 12 of the band, this section of the casing being heated by means of heater elements 13 under separate control, e. g. by means of cocks 14 so as to regulate the temperature conditions along this run. The atmosphere within the casing on the

upper run may be maintained substantially saturated with acetone which is withdrawn through an outlet 15 for recovery.

The lower run 16 of the band is also enclosed by the casing 8, and air is admitted at 17 to complete the drying of the foil on the band, this air, together with evaporated solvent, being withdrawn by the outlet 18. The foil is stripped from the band at the roll 6 and wound in a manner to be described later. The lengths of the drying runs depend on the conditions under which the machine is to work, such as band speed, and thickness of foil to be produced.

In order to tension the band, and especially to put it under even tension over its whole width, the gearing shown in detail in Figs. 2 and 3 is employed. The drum 7 is mounted in bearing blocks 19 longitudinally movable in slides 119 on the machine frame. The blocks 19 are connected (as shown in Fig. 1) to long screwed rods 20 on which are screwed nuts 21. On each nut 21 is slidably keyed a hand wheel 22 which enables each bearing block 19 to be given a coarse-adjustment in the hand wheel of the other block, or, by means of bevel gears 23 keyed to the nuts 21 and connected together by bevel gears 24 on the cross shaft 25, for both of the bearing blocks to be given a coarse-adjustment by operation of either of the hand wheels 22. When independent adjustment is required, one of the gears 24 may be slid out of engagement with its bevel 23 being slidably keyed to the shaft 24 for this purpose, as shown in Fig. 2.

Freely mounted on each nut 21 is a worm wheel 26 fitted with dog teeth 27 adapted to engage corresponding teeth 28 on the hand wheel 22. The hand wheel 22 is normally urged by a spring 29 to bring about engagement between the teeth 27, 28 so as to clutch the worm wheel 26 to the hand wheel 22. A pivoted latch 30, however, enables the worm wheel 26 and the hand wheel 22 to be kept out of engagement with each other.

For convenience in assembly, the nut 21 has keyed to it a sleeve 121 to which the hand wheel 22 and the bevel gear 23 are keyed and on which the worm wheel 26 is free to rotate.

The worm wheels 26 engage worms 31, 32, the worm 32 being secured to a cross shaft 33 while the worm 31 is carried by a sleeve 34 freely mounted on the shaft 33. At one end of the shaft 33 is secured a toothed member 35 adjacent to which is a second toothed member 36 secured to the sleeve 34.

A housing 37 carried by a hand wheel 38 on the end of the shaft 33 is toothed internally at 39 to mesh with the toothed members 35, 36.

The housing 37 is slidable with respect to the shaft 33 so as to bring the teeth 39 into engagement with both of the toothed members 35, 36 or with either of these as desired, a plunger 40 enabling the housing to be retained in any selected

position. With both members 35, 36 engaged, rotation of the hand wheel 38 causes the worms 31, 32 to rotate both of the worm wheels 26, so that if both of these wheels are clutched to the hand wheels 22 on the screwed rods 20, both bearing blocks 19 are moved to an equal extent, the worm gearing enabling a fine adjustment to be effected in the position of the blocks. With only one of the members 35, 36 in engagement, the corresponding worm 31 or 32 is rotated by the hand wheel 38 so that fine adjustment is effected in the corresponding bearing block 19. The adjusting gear is carried by brackets 41 from the casing 8.

In Fig. 4 is shown a similar adjusting gear with, however, the connecting bevels 24, 26 omitted, coarse-adjustment of the blocks 19 being effected by independent operation of the hand wheels 22. If desired, however, provision may be made for simultaneous adjustment as shown in Figs. 2 and 3. The adjusting gear in Fig. 4 is carried by a frame 42 slidably mounted on rods 43 connected to the frame of an air cylinder 44. The frame 42 is connected to a ram 45 working in the air cylinder.

Coarse-adjustment of the band tension can be effected by the hand wheels 22 and fine adjustment by means of the hand wheel 38, this adjustment taking place relative to the frame 42. During operation of the machine, the band is maintained tensioned by means of the cylinder 44, and since both bearing blocks 19 are affected equally by the frame 42, even tension is maintained across the width of the band.

The foil is stripped by means of the roller 46 slightly spaced from the drum 6 and is wound on to a spool 47 contacting with the roller 46. In order to wind the foil smoothly, the spool 47 is driven by friction wheels 48, 49 which tend to over-drive the spool. On completion of the spool 47, a second spool 50 is swung into position against the roller 46, the spools being carried on an arm 51, pivoted in the lower end of a swinging frame 52 carried by a shaft 53 bearing a sprocket 54 by which the friction gear is driven. For further details of this take-up device, reference should be had to U. S. application S. No. 499,950, filed 4th December, 1930.

What I claim and desire to secure by Letters Patent is:—

1. Apparatus for the manufacture of films and foils, said apparatus comprising an endless flexible band of nickel, cold-worked after jointing so as to be substantially uniform over its whole length.

2. Apparatus for the manufacture of films and foils, said apparatus comprising an endless flexible band of nickel, jointed by hammer-welding, and cold-worked after jointing so as to be substantially uniform over its whole length.

EDWARD KINSELLA.