

(No Model.)

3 Sheets—Sheet 1.

H. H. FEFEL.
SEWING MACHINE.

No. 523,932.

Patented July 31, 1894.

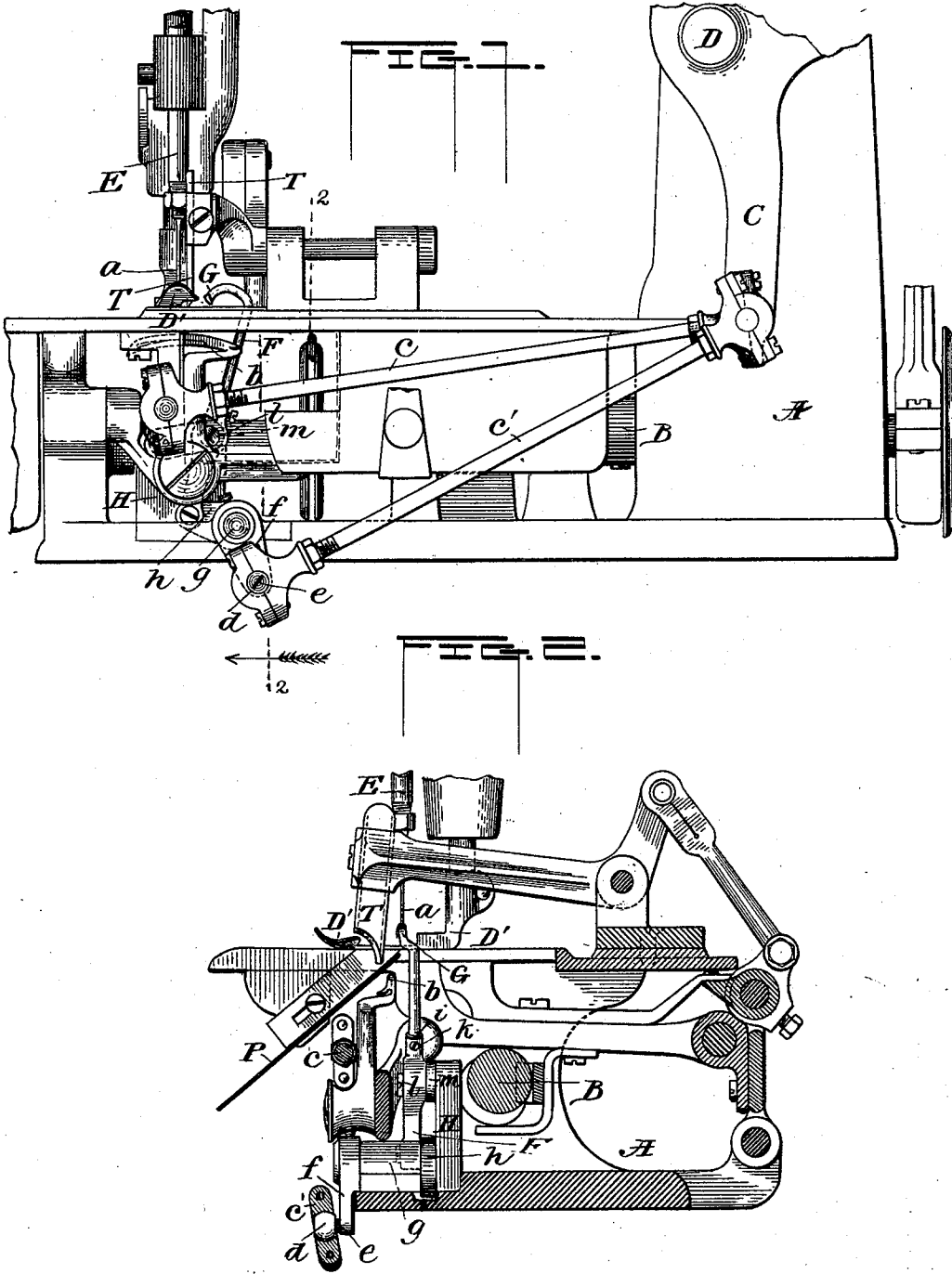

Witnesses
L. A. Comstock
Gallop P. Moore

Inventor
Henry H. Fefel
 By *Chas. S. Sturtevant*
 Attorney

H. H. FEFEL.
SEWING MACHINE.

No. 523,932.

Patented July 31, 1894.

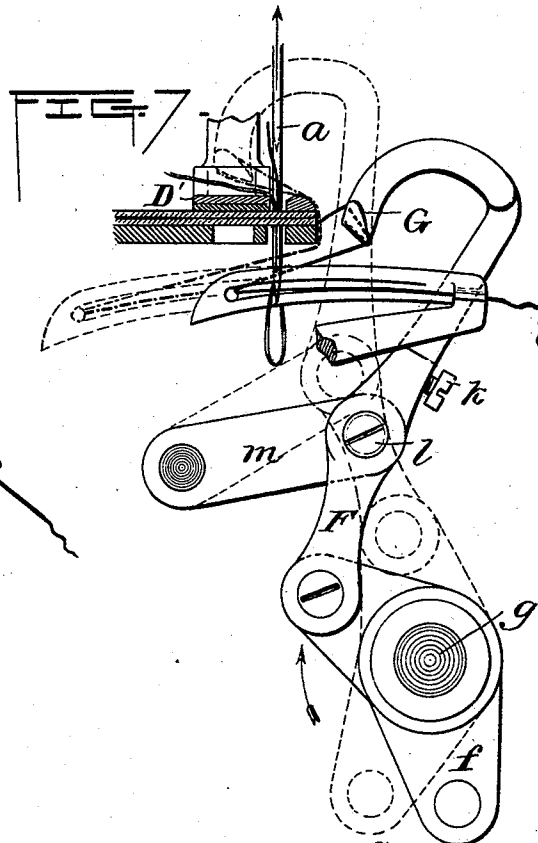
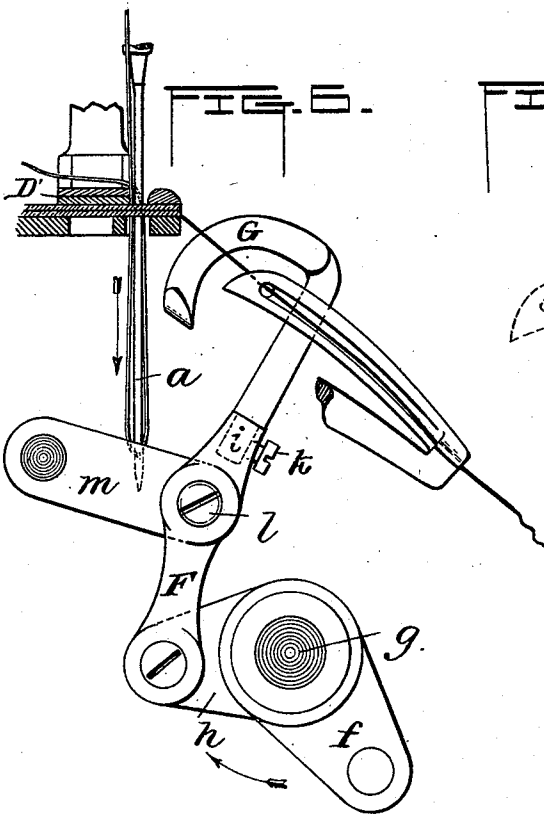
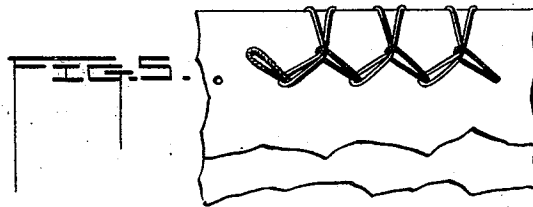
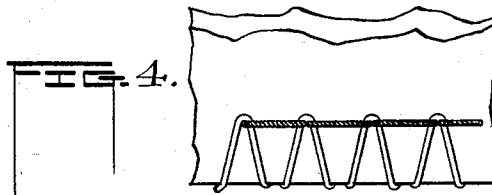
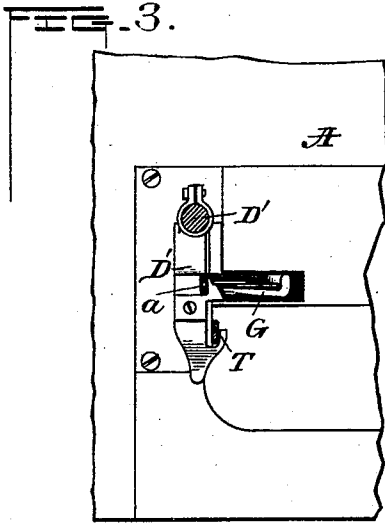

Witnesses
L. A. Conner Jr.
Gales P. Moore.

Henry H. Fefel
By Chas. Sturtevant,
 Attorney

(No Model.)

3 Sheets—Sheet 3.

H. H. FEFEL.
SEWING MACHINE.

No. 523,932.

Patented July 31, 1894.

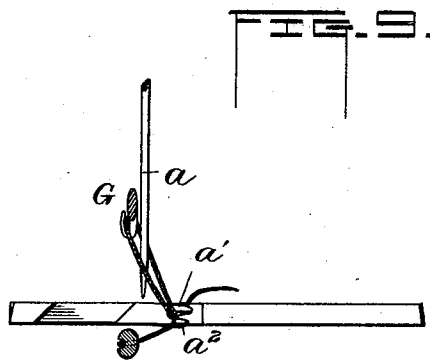
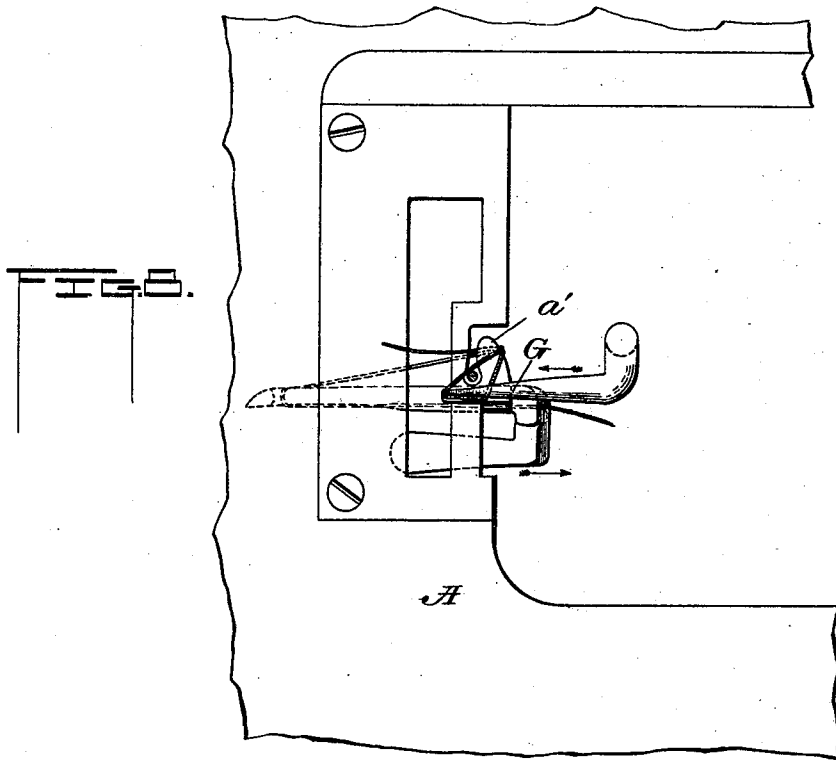

Witnesses

L. A. Connor Jr.
Elias P. Moore

Inventor
Henry H. Fefel
By *Chas. S. Steward.*
Attorney

UNITED STATES PATENT OFFICE.

HENRY H. FEFEL, OF NEW YORK, N. Y., ASSIGNOR TO THE UNION SPECIAL SEWING MACHINE COMPANY, OF CHICAGO, ILLINOIS.

SEWING-MACHINE.

SPECIFICATION forming part of Letters Patent No. 523,932, dated July 31, 1894.

Application filed August 3, 1892. Serial No. 442,001. (No model.)

To all whom it may concern:

Be it known that I, HENRY H. FEFEL, a citizen of the United States, residing at New York, in the county of New York and State of New York, have invented certain new and useful Improvements in Sewing-Machines, of which the following is a description, reference being had to the accompanying drawings, and to the letters of reference marked thereon.

My invention relates to an improvement in sewing machines, and particularly to that class of machines used for overseaming or uniting the edges of fabrics.

In an application filed by me June 29, 1892, Serial No. 438,418, I have claimed a seam and a method of uniting fabrics, and in the present case describe and claim the machine which I have devised to make that seam and carry out said method.

This invention has relation especially to that class of machines in which a spreader working from below up through the cloth plate carries a loop of thread over the edge of the fabric, where it is secured on the upper surface by the sewing needle passing through the loop, and embodies certain new and useful improvements in the working parts of machines of that general character.

My invention consists in the matters hereinafter described and referred to in the appended claims.

In the accompanying drawings which illustrate my invention Figure 1 is a side elevation of so much of a sewing machine as is necessary for a full understanding of my invention. Fig. 2 is a view partly in section on line 2—2, Fig. 1. Fig. 3 is a plan view of the work plate and presser foot. Fig. 4 is a top view of the seam made on my machine. Fig. 5 is a bottom view thereof. Figs. 6 and 7 represent respectively the positions of the looper, needle, and spreader in the various movements thereof incident to the formation of the stitch. Fig. 8 is a plan view of a throat plate showing the retainer for the under thread when carried over the edge by the spreader; and Fig. 9 is a side view of the same.

In the drawings, A represents a portion of the frame of the machine.

B is the main shaft.

C is the downward extension of the needle arm which is pivoted to the frame of the machine at D.

E is the needle bar supporting the thread carrying, eye-pointed needle *a*.

D' is the presser foot having a tongue *l* over which the spreader lays the thread. This tongue is herein shown as made integral with the presser foot but it will of course be understood that the particular way in which it is attached to said presser foot is not essential. Co-operating with the needle *a* is the looper *b* actuated by means of the looper rod *c* from the extension C of the needle arm lever. Power is communicated to the parts in the usual manner.

The parts above referred to are all identical in construction with the corresponding parts in the well known Union Special Sewing Machine and do not need further explanation.

I do not wish to be limited to any particular construction of feeding mechanism, as any suitable for the purpose may be used.

A rod *c'* similar in all respects to the looper rod *c* is connected at one end to the needle arm extension C just as is the looper rod, and at its opposite end is secured to it a split bearing in which is journaled a ball *d* on the end of a stud *e* secured on the lower end of a crank *f*, attached to the shaft *g*. A second crank *h* is attached on this shaft and carries a stud upon which is secured the lower end of the spreader support F. This spreader support may be in one piece with the spreader G but is preferably provided with a socket *i* in which the shank of the spreader is secured by a set screw *k*. The support F is pivoted as shown at *l* to a link *m* which in turn is pivoted to an upwardly extending arm or standard H. The spreader is of well known construction and is provided with a projection adapted in the backward movement to catch the looper thread to carry it above the fabric.

It will be seen that by the manner of supporting the spreader and transmitting motion to it through the cranks *f* and *h*, it has a movement from below the cloth plate parallel with the needle up through the plate over the edge of the fabric to a point in front of the needle.

The movement of the spreader in co-operating with the looper and needle is shown in detail in Figs. 6 and 7, in the former the spreader being in its lowest position, while in 5 the latter it is at the highest point in its travel.

The looper carrying the under thread is in its farthest backward position when the spreader is in its lowest position. The needle and looper being threaded, the needle in 10 its lowest position, the looper in its retracted position and the spreader in its lowest position, as shown in Fig. 6 the machine is started. In the forward movement of the looper it carries a loop of the under thread through the 15 loop which has been formed in the needle thread, and the spreader rising, catches up the under or looper thread and carries it up over the edge of the fabric forming a loop upon the upper surface of the fabric through 20 which the needle in its next downward movement may pass, the loops in the under thread which lie on the under surface of the fabric first lying within and then encircling the loops in the needle thread brought down 25 through the fabric.

It has been found desirable in practice in some instances to provide a place to retain the under thread when carrying it up so that 30 the needle in its descent will pass on the back side of said thread and prevent dropping stitches. My invention, therefore, further includes a means for accomplishing this object. As herein shown in Figs. 8 and 9 the throat 35 plate is provided with a tongue *a'* of well known construction, over which the stitch is formed. Beneath this tongue and to the right of the needle is attached a second tongue as *a''*, and as shown in Figs. 8 and 9 in the upward 40 movement of the spreader *G* the under thread is forced into the space or notch between these two tongues and thereby held at such an angle that the needle in its descent will invariably pass down through the loop 45 formed in the thread, thereby deflected and preventing any dropping of stitches.

I do not wish to be limited to any particular construction of retainer as other means 50 for accomplishing the desired result may be devised, but I have found the above to work satisfactorily in practice. The use of this retainer still further facilitates the working of the machine in that it will commence to form a chain without first placing a piece of 55 fabric under the presser foot.

I have shown in the present application a peculiar form of trimmer *T* actuated from the feed rocker and pivoted to a standard on the cloth plate of the machine as shown in Fig. 2. 60 It will also be understood that any desired form of feeding mechanism may be provided so I do not wish to be at all limited in this respect.

Various modifications and changes from 65 the exact construction herein illustrated may suggest themselves to any one skilled in and familiar with the art and I intend to include

all such modifications within the scope of my invention.

The trimmer and angular guard plate here- 70 in shown, but not claimed, form the subject matter of an application filed by me in the United States Patent Office, on the 23d day of August, 1892, Serial No. 443,832.

Having thus described my invention, what 75 I claim as new, and desire to secure by Letters Patent, is—

1. In a sewing machine, in combination with stitch forming mechanism including a vertically reciprocating eye-pointed needle carrying an upper thread, an under thread-carrying device operating entirely below the 80 cloth plate, a spreader consisting of a single pivoted lever working in a single plane from below up through and above the cloth plate 85 of the machine to carry up the under or looper thread over the edge of the fabric where it is secured by the needle thread, and means for operating said spreader; substantially as described. 90

2. In a sewing machine, in combination with a vertically reciprocating eye-pointed needle carrying an upper thread and its complementary stitch forming mechanism comprising a looper carrying a separate under thread, of a 95 spreader independent of the looper and consisting of a single pivoted lever working in a single plane from below up through and above the cloth plate of the machine to carry up the under or looper thread over the edge of the 100 fabric in the plane of vertical movement of the needle whereby it is secured by said needle thread, and means for operating said spreader; substantially as described.

3. In a sewing machine, the combination 105 with suitable complementary stitch forming mechanism and including a needle arm as *C*, and an under thread carrying device, a spreader independent of the under thread carrying device arranged to cooperate with 110 the complementary stitch forming mechanism to carry the under thread from below up over the edge where it is secured by the needle thread, and an oscillating connection between the needle arm and the spreader; sub- 115 stantially as described.

4. In a sewing machine, in combination with stitch forming mechanism including a vertically reciprocating thread carrying eye-pointed needle for an upper thread, an under 120 thread carrying device, a spreader consisting of a single pivoted lever independent of the under thread carrying device and working from below up through and above the cloth plate of the machine to carry up the under 125 thread over the edge where it is secured by the needle thread, a needle arm pivoted to the machine frame, an oscillating connection between the needle arm and the under thread carrying device and between the former and 130 the spreader; substantially as described.

5. In a sewing machine, the combination with suitable complementary stitch forming mechanism including a needle arm having a

downward extension, of an under thread carrying looper, a rod driving the same secured at one end to said extension, a spreader arranged to cooperate with said complementary stitch forming mechanism and looper to carry the under thread from below up over the edge where it is secured by the needle thread, and a rod *c'* driving the same and connected at one end to the needle arm extension; substantially as described.

6. In a sewing machine, the combination with the vertically reciprocating needle and under thread carrying looper, the needle arm having a downward extension in operative connection with the looper, of a spreader working from below up through and above the cloth plate of the machine to carry the under thread over the edge where it is secured by the upper needle, said spreader getting its motion from said extension on the needle arm; substantially as described.

7. In a sewing machine, the combination with the needle, the looper, a needle arm having an extension to which extension the looper is operatively connected, of a spreader having a lever and double crank connections with the needle arm extension and arranged to carry the looper thread from a point parallel with the needle below the cloth plate, up over the edge of the fabric to a point where the needle will pass down through the loop of the thread and secure the same to the fabric; substantially as described.

8. In a sewing machine and in combination with the needle arm and suitable stitch forming mechanism, a pivoted arm as *F* having a crank and rod connection with the needle arm and provided with a socket, and a spreader as *G* secured within said socket; substantially as described.

9. In a sewing machine, in combination with the vertically reciprocating thread carrying needle and complementary stitch forming mechanism including a device carrying a separate under thread, a spreader independent of the under thread carrying device arranged to take the under thread and carry it in position within the plane of vertical movement of the needle, means for operating said spreader, and a stationary deflecting device and holder for said under thread arranged above the plane of movement of the under thread carrying device and to one side of the plane of reciprocation of the needle whereby in the movement of the spreader said under thread is caught by the deflector and held at such an angle that the needle will pass through the loop; substantially as described.

10. In a sewing machine, the combination with suitable stitch forming mechanism including an under thread carrying device, of a retaining device for said under thread, comprising two parallel fingers projecting from the cloth plate, with a recess between, the upper finger being of greater length than the lower, and a spreader working from below

up through and above the cloth plate, and arranged to carry the thread into said recess in its upward movement; substantially as described.

11. In a sewing machine, in combination with the vertically reciprocating needle and complementary stitch forming mechanism including a device carrying a separate under thread, a throat plate provided with a tongue over which stitches are formed, a spreader arranged to take the under thread and carry it in position within the plane of vertical movement of the needle with means for operating said spreader, and a retainer for said under thread attached to the throat plate to the right of the needle and beneath the tongue on the throat plate; substantially as described.

12. In a sewing machine, in combination with the needle arm having a downward extension, and complementary stitch forming mechanism, a spreader, a support therefor, the crank *h* attached to the support, the shaft *g*, the crank *f*, and the connecting rod *c'*, driving the crank *f* and connected at its opposite end with the needle arm extension; substantially as described.

13. In a sewing machine, in combination with the needle arm having a downward extension and complementary stitch forming mechanism, a spreader, a support therefor, a pivoted link *m*, to which said support is pivoted, a crank *h* pivotally attached to the lower end of said spreader support, the shaft *g* to which said crank is secured at one end, the crank *f* secured to the opposite end of the shaft *g*, the rod *c'* secured at one end to the needle arm extension, and a ball joint connecting the opposite end thereof with said crank *f*; substantially as described.

14. In a sewing machine having a presser foot, in combination with the vertically reciprocating needle carrying an upper thread, an under thread carrying device, a throat plate provided with a tongue over which the stitches are formed, a spreader independent of the under thread carrying device arranged to take the under thread and carry it in position within the plane of vertical movement of the needle, means for operating said spreader, and a combined deflecting and retaining device for said under thread independent of the presser foot and of the tongue on the throat plate; substantially as described.

15. In a sewing machine having a cloth plate, in combination with a vertically reciprocating thread carrying needle, a device carrying a separate under thread, a spreader independent of the under thread carrying device arranged to take the under thread and carry it up over the edge of the fabric where it is secured by the needle thread, means for operating said spreader, and a stationary combined retaining and deflecting device located below the cloth plate and so arranged with respect to the path of movement of the

spreader as to catch and hold the under thread when carried up thereby; substantially as described.

5 16. In a sewing machine, a throat plate provided with a tongue over which the stitches are formed, stitch forming mechanism including a spreader and a vertically movable needle
10 said spreader working from below up through and above the cloth plate of the machine and carrying a thread from below, over the tongue
15 on the throat plate into the path of vertical movement of the needle, and a combined deflecting and retaining device located to one side of the needle and in a plane above the
20 plane of the lowest position of the spreader, but intersecting the path of the thread carried up by the spreader, whereby in the upward movement of said spreader, the thread is carried into the retainer and deflected and held therein while the needle passes through the loop; substantially as described.

17. In a sewing machine, in combination with suitable stitch forming mechanism, a throat plate provided with a tongue over
25 which the stitches are formed, a second tongue parallel therewith and beneath the same, with a deflecting and holding recess between the

two, into which the under thread is adapted to pass; substantially as described.

18. In a sewing machine, the combination 30 with two reciprocating thread carrying devices cooperating to form stitches, and a spreader independent of the said thread carrying devices, of a single lever and independent operative connections between the lever 35 and said several parts, with means for operating said lever; substantially as described.

19. In a sewing machine, a cloth plate suitable stitch forming mechanism including a device for carrying a thread from below up 40 through and above the cloth plate of the machine, said cloth plate being provided with a thread deflecting and retaining recess so located with respect to the path of movement 45 of the thread carrying device as to catch and hold the thread when carried up thereby, substantially as described.

In testimony whereof I affix my signature in presence of two witnesses.

HENRY H. FEFEL.

Witnesses:

ALFRED FLOCK,
WM. H. BOYER.