

A. C. RICKEY & M. D. NORRIS.

LEATHER-PUNCHING MACHINE.

No. 177,159.

Patented May 9, 1876.

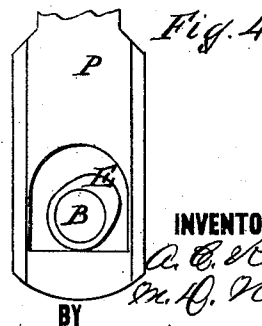
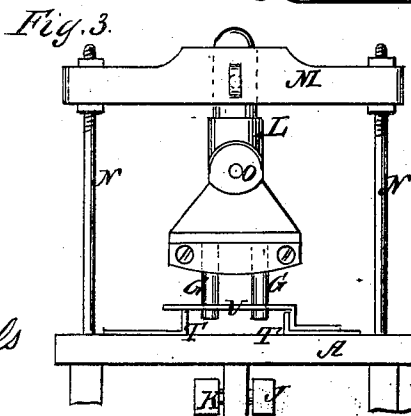
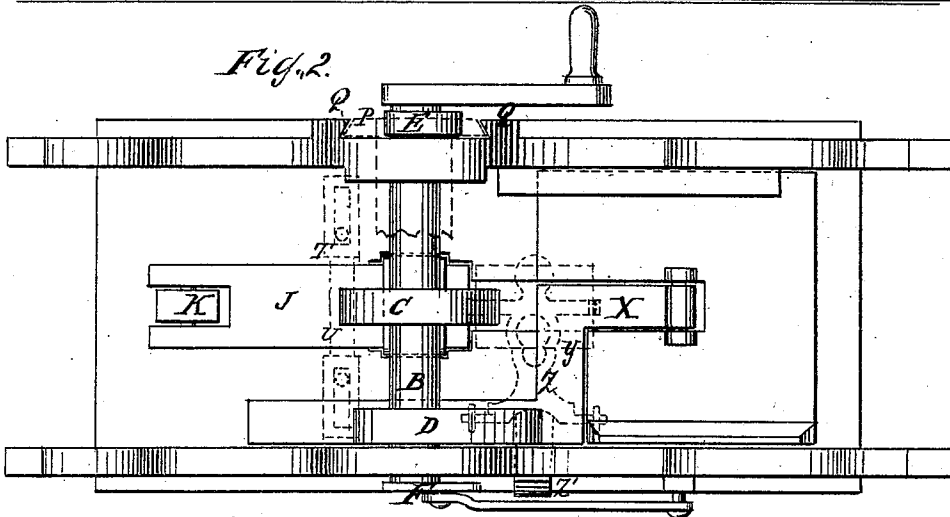
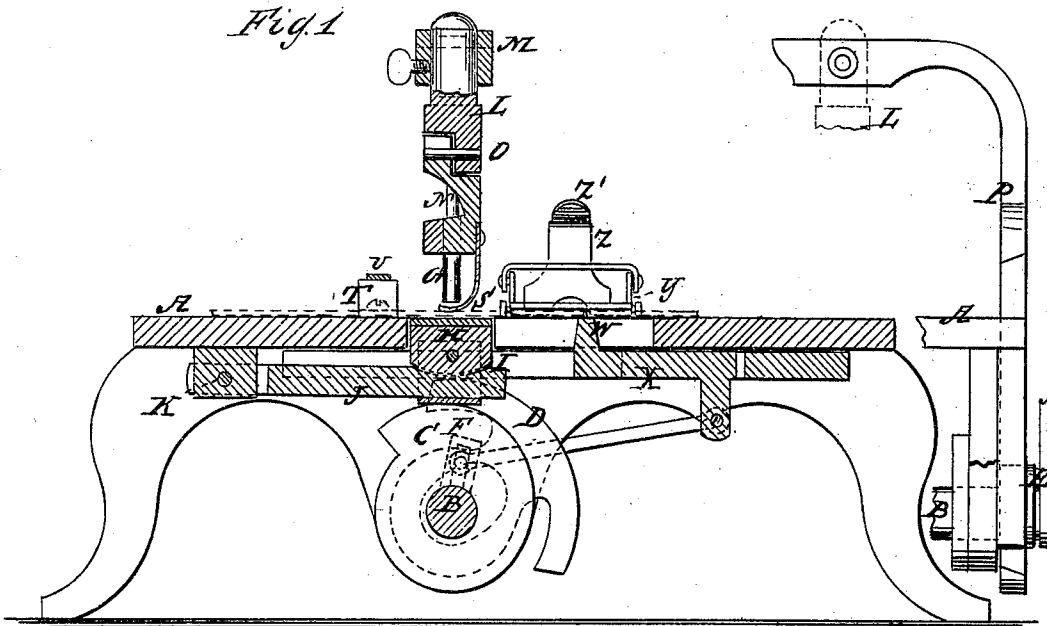

WITNESSES:

E. Woff
J. Goethals

INVENTOR:

A. C. Rickey
M. D. Norris

BY
Munn
ATTORNEYS.

UNITED STATES PATENT OFFICE.

ALONZO C. RICKEY AND MARTIN D. NORRIS, OF ELDORA, IOWA.

IMPROVEMENT IN LEATHER-PUNCHING MACHINES.

Specification forming part of Letters Patent No. **177,159**, dated May 9, 1876; application filed March 25, 1876.

To all whom it may concern:

Be it known that we, ALONZO C. RICKEY and MARTIN D. NORRIS, of Eldora, Hardin county, Iowa, have invented a new and Improved Leather-Punching Machine, of which the following is a specification:

Our invention consists of a contrivance or devices for punching leather straps of all kinds, but more particularly bars for leather fly-nets for horses, the same being adapted for punching either by movable or stationary punches, and a feed mechanism worked by a shaft fixed transversely under the bed, to be turned by hand or other means.

Figure 1 is a longitudinal sectional elevation of our improved machine. Fig. 2 is a plan of the machine inverted. Fig. 3 is an end elevation, and Fig. 4 is a detail of the contrivance for working the movable punch.

Similar letters of reference indicate corresponding parts.

A is the bed of the machine, under which is a cam-shaft, B, carrying cams C, D, and E, and the crank F.

The cam C pushes the leather to be punched up against the punches G by the movable punching-bed H, which is pivoted to and has a rocking seat, I, on the bar J, which rests on the cam, and is pivoted to the frame at K, to keep it in position, and allow the bed H to rise and fall with the cam.

The punches may be stationary or movable. In Fig. 1 they are represented stationary, being attached to a stock, L, which is fastened in a cross-head, M, supported on the standards N, the stock being adjustable up and down on the standards to regulate the height of the punches, and the punch-stock is jointed at O, to allow the punches to be self-adjusting to the face of the bed H. The punches will, in practice, be adjustable toward and from each other when two are used, to be set according to the distance apart the holes are required to be.

For some work it is desirable to use movable punches, which we provide for by employing the vertical sliding bar P, with top overhanging the bed, to carry the punch-stock L, said bar being fitted in the ways Q in one side of the frame, and worked by the cam E, the cross-head M and posts N being removed. The spring-presser S is employed to strip the straps off the punches.

T and U represent the guides for regulating the straps to the punches. W is the feeder. It is attached to the reciprocating bar X, worked by the crank F, and raised by the cam D. Y is a presser to keep the work on the feeders. It is pivoted to the forked elbow Z, pivoted to the bed, and pressed down by the spring Z'.

Having thus described our invention, we claim as new and desire to secure by Letters Patent—

1. The combination of bed H, cam C, and punches G, substantially as specified.
2. The feeder W, slide X, cam D, crank F, and presser Y, combined with punches G, substantially as specified.
3. The presser Y, forked elbow Z, and spring Z', combined with the feeder W, substantially as specified.
4. The vertically-sliding punch-carrying bar P, arranged in ways in the side of the frame, and overhanging the bed, and the cam E, combined and arranged substantially as specified.
5. The jointed punch-stock L, in combination with the bed H, substantially as specified.

ALONZO C. RICKEY.
MARTIN D. NORRIS.

Witnesses:

W. J. MOIR,
I. L. HART,
J. S. ROSS.