

J. J. McNALLY.
COTTON GIN.

APPLICATION FILED MAY 8, 1911.

Patented Sept. 5, 1911.

3 SHEETS—SHEET 1.

1,002,598.

Fig. 1

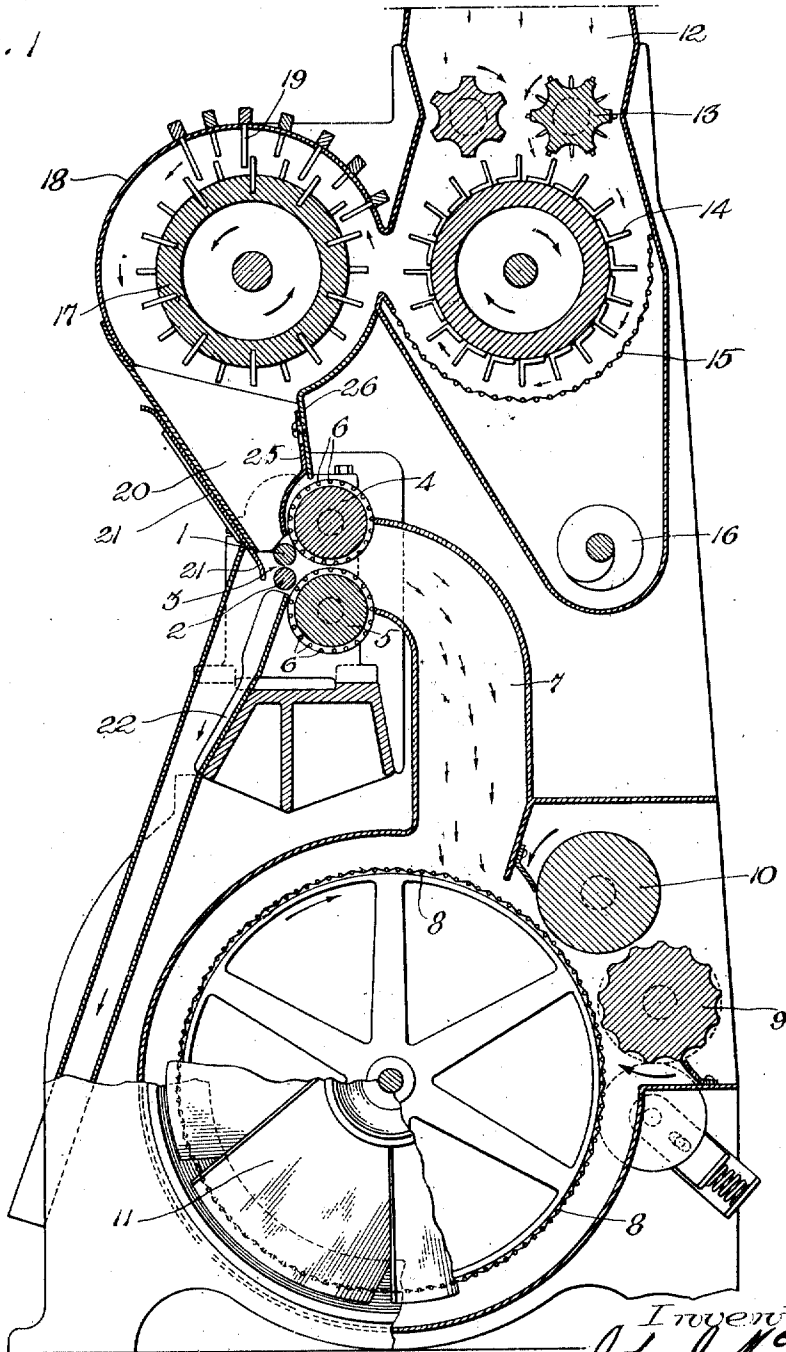

Witnesses:
M. L. Kilman
H. D. McPhail

Inventor:
John J. McNally
by Phillips Van Evers & Fish
Attorneys.

J. J. McNALLY.

COTTON GIN.

APPLICATION FILED MAY 6, 1911.

1,002,598.

Patented Sept. 5, 1911.

3 SHEETS—SHEET 2.

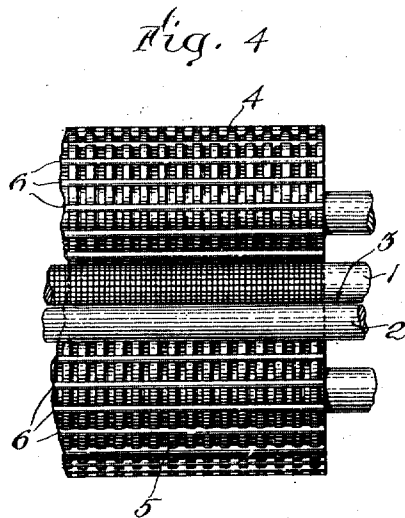
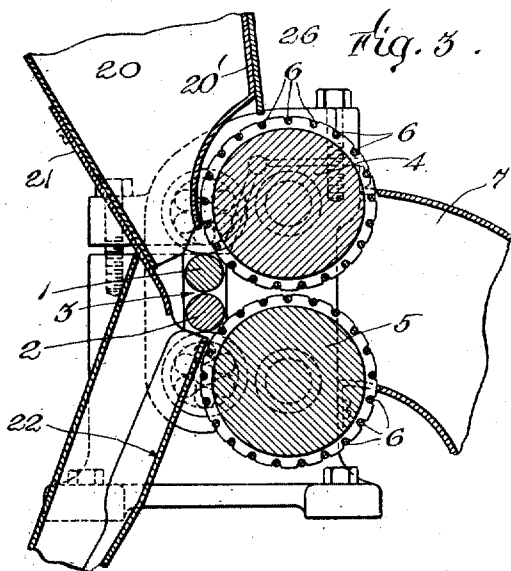
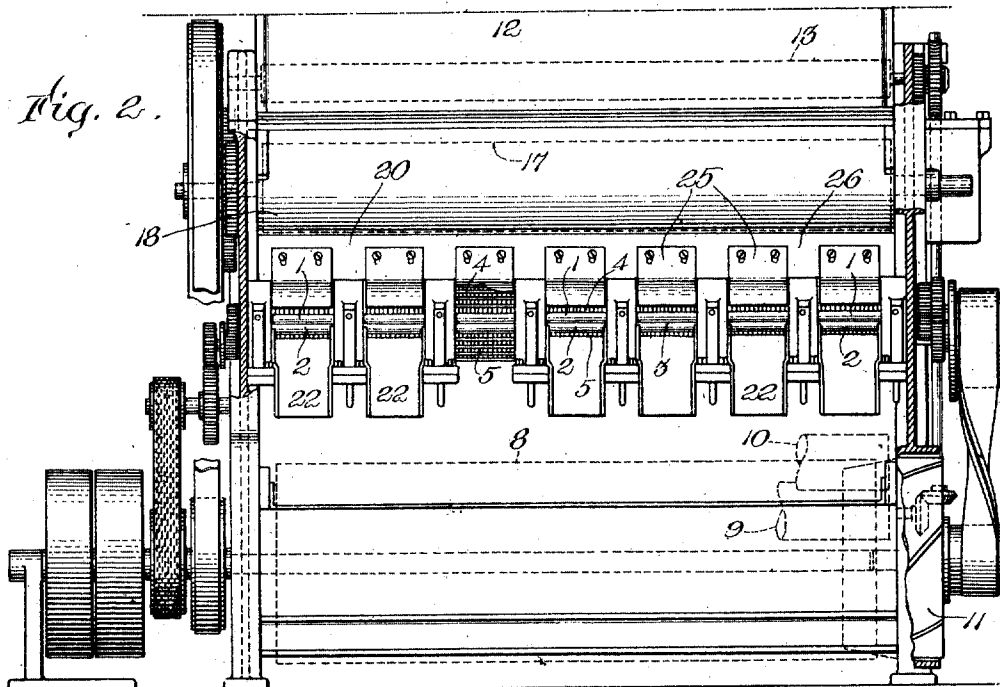

Witnesses:
M. L. Kilman
H. D. McPhail

Inventor:
John J. McNally
By Phillips Van Euren & Fish
Attorneys.

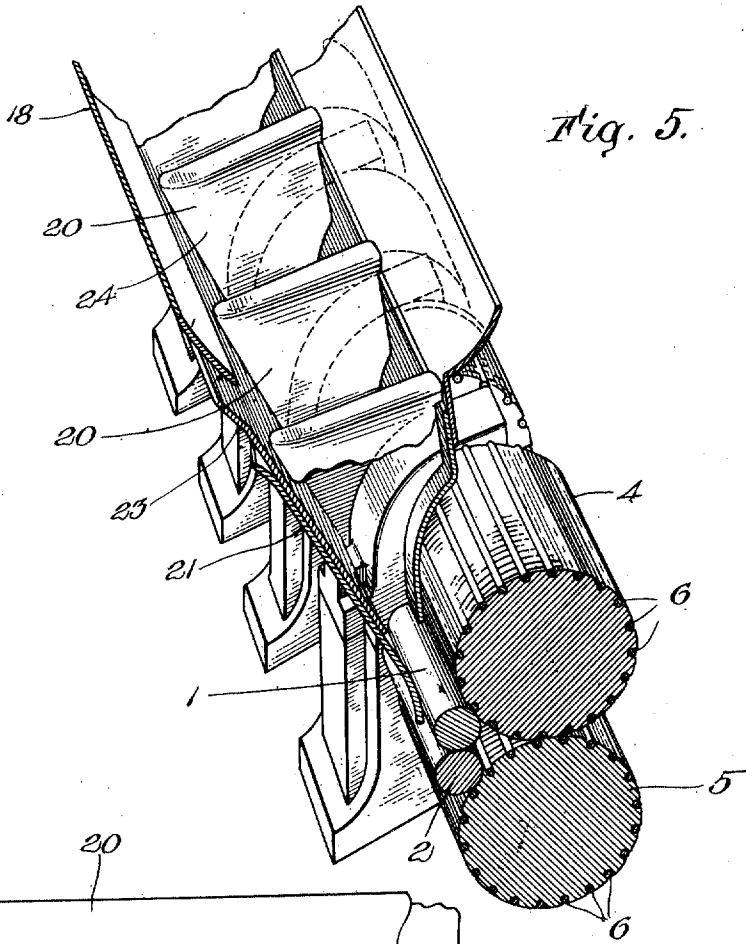

Fig. 5.

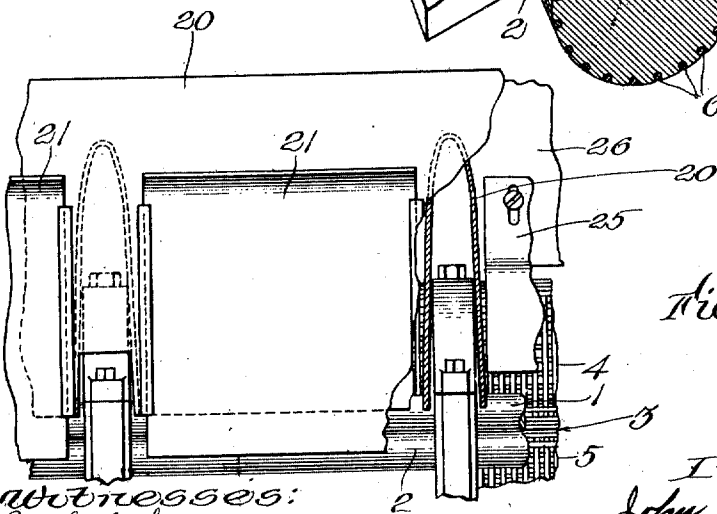

Fig. 6.

Witnesses:
M. L. Gibman,
H. D. McPhail

Inventor:
John J. McNally
by Phillips Van Orman & Fish
ATTORNEYS

UNITED STATES PATENT OFFICE.

JOHN J. McNALLY, OF NORFOLK, VIRGINIA, ASSIGNOR TO McNALLY PNEUMATIC GIN CORPORATION, OF NORFOLK, VIRGINIA, A CORPORATION OF VIRGINIA.

COTTON-GIN.

1,002,598.

Specification of Letters Patent.

Patented Sept. 5, 1911.

Application filed May 8, 1911. Serial No. 625,813.

To all whom it may concern:

Be it known that I, JOHN J. McNALLY, a citizen of the United States, residing at Norfolk, in the county of Norfolk and State of Virginia, have invented certain new and useful Improvements in Cotton-Gins; and I do hereby declare the following to be a full, clear, and exact description of the invention, such as will enable others skilled in the art to which it appertains to make and use the same.

The invention relates to gins for separating cotton or similar fibrous material from the seed, and more particularly to that class of gins known as roller gins, in which the fibers are separated from the seeds by the action of one or more ginning rolls.

It is the object of the invention to provide a novel and improved construction of roller gin whereby the fibers of the cotton may be readily removed from the seeds without danger of breaking or reducing the length of the fiber, or of subjecting the fiber to such pressure as would crush or injure it, and whereby the cotton drawn from the seeds by the rolls may be efficiently removed from the surface of the rolls and delivered without injury to the fiber.

To these ends the invention consists in the features and combinations of parts hereinafter described and set forth in the claims.

The various features of the invention will be readily understood from an inspection of the accompanying drawings and the following detailed description of the machine illustrated therein.

In the drawings Figure 1 is a vertical sectional view showing a cotton gin embodying the invention in its preferred form; Fig. 2 is a front elevation; Fig. 3 is a detail sectional view showing the ginning rolls and stripping rolls; Fig. 4 is a detail front elevation of the rolls shown in Fig. 3; and Figs. 5 and 6 show details of the breast plate.

In the machine shown in the drawings the devices for stripping the cotton fiber from the seeds comprise two metal ginning rolls 1 and 2 which are mounted in fixed bearings and are arranged one above the other and with their adjacent peripheries spaced apart from four to six one thousandths of an inch. The rolls are preferably of the same diameter, and are of such size that their periph-

eries form a receiving throat 3 the converging sides of which are at such an angle that the cotton seeds will not be carried between the rolls by the rapid rotation thereof. The separation of the rolls is important to their successful operation upon the cotton, since this allows the cotton which is stripped from the seeds by the rapid rotation of the rolls to be carried through between the rolls without danger of subjecting the fiber to a crushing grip or bite such as would injure the fiber. The efficiency of the rolls may be increased by providing the surface of one of the rolls, preferably the upper one, with shallow grooves extending longitudinally and circumferentially of the roll, and providing the other roll with a smooth unbroken surface. With this construction the upper roll has an effective drag or drawing action on the cotton fiber, while the lower roll offers a smooth cooperating surface for retaining the locks of cotton against the surface of the upper roll until the fiber has been drawn from the seed. By providing one of the rolls with a smooth surface, the gripping and breaking of the ends of the cotton seed which might occur if both rolls were grooved or roughened, is avoided. The cotton fibers which are drawn from the seeds and carried between the ginning rolls tend to cling to the surfaces of the rolls and wrap about the rolls. It is necessary, therefore, that the cotton fiber be removed or stripped from the surface of the ginning rolls, and this must be accomplished and the cotton delivered without injury to the fiber.

The means employed for removing the cotton fiber from the surface of the ginning rolls constitutes one of the important features of the present invention. In accordance with this feature of the invention the cotton fiber is removed from the surface of the rolls by directing a current of air across the periphery of each of the ginning rolls in a direction opposite to its travel. The jets or ribbon of air passing across the periphery of the ginning roll directs the leading ends of the cotton fibers away from the periphery of the roll and removes practically all the cotton from the surface of the roll without injury to the fiber. It has been found, however, that occasionally some of the fiber will adhere to the roll and will pass beyond the point of application of the air current or

jet. In order that any such adhering fiber may be stripped from the surface of the roll, a further feature of the invention contemplates providing stripping devices which travel close to the surface of the ginning rolls in the same direction as the air current, and strip from the rolls any adhering fiber which has not been removed by the air currents.

In the construction shown, the means for directing a current of air across the periphery of the rolls, and for stripping any adhering cotton from the surface of the rolls, comprises two stripper rolls 4 and 5 arranged at the rear of the ginning rolls, and each driven at a high speed in the same direction as the cooperating ginning roll. These stripper rolls are of comparatively large size, and are provided on their surfaces with alternating circumferential grooves and ribs. The grooves are comparatively shallow, and the surfaces at the bottoms of the grooves form the cylindrical bodies of the rolls. The rolls are provided with longitudinal rods or bars 6 which are spaced from the bottoms of the grooves and form strippers which travel close to the surface of the ginning rolls, as indicated in Figs. 1 and 3. The rolls are also so arranged that their peripheries travel close to each other back of the ginning rolls, and act to guide and carry away the cotton fiber after it has passed between the ginning rolls and been removed therefrom by the air currents. A chute 7 is arranged at the rear of the stripper rolls, and a suction device is connected with this chute and draws air through the space between the bodies of the stripper rolls and through the restricted passages formed between the bodies of the rolls and the peripheries of the ginning rolls. The spacing of the bars 6 from the bodies of the stripper rolls allows a continuous flow of air between the stripper rolls and ginning rolls, and also allows the air to flow under any cotton fiber which may tend to adhere to the surface of the stripper rolls and to be carried around with the rolls. This insures the removal of the cotton fiber from the surface of the ginning rolls, and also the removal of the fiber from the surface of the stripper rolls, and its delivery into the chute 7, without injury to the fiber. Any fiber which may not be removed from the surface of one of the ginning rolls by the current of air passing between the roll and the cooperating stripper roll, will be stripped from the surface of the ginning roll by the stripper bars 6, so that the surfaces of the ginning rolls will be kept substantially free from cotton fiber, and in condition to act efficiently on the cotton.

The chute 7 directs the cotton against the periphery of a condenser drum 8 which is provided with the usual wire covering and is

arranged at the mouth of the chute. The cotton is removed from the surface of the condenser drum by a doffing roll 9 and cooperating pressure roll 10 of usual construction. The means for creating a suction and flow of air through the chute 7 and between the stripper and ginning rolls comprises a fan 11 mounted at the end of the condenser drum so that it will act to create a flow of air through the drum and chute 7, and between the rolls.

The cotton to be ginned is placed in a hopper 12, and is fed by slowly rotating feed rolls 13 to a picker roll 14 which is partially surrounded by a screen 15. The picker roll is driven at a comparatively high speed, and the projecting pins on the roll take the cotton from the rolls 13 and carry it over the screen 15, through which any dirt or dust passes, and is removed by a conveyer 16. The masses of cotton carried by the picker roll 14 are further separated and are broken up into separate locks by a second picker roll 17 which is driven at a somewhat higher speed than the roll 14, and rotates within a cylindrical casing 18. The casing is provided with inwardly projecting pins 19. Alternate rows of the pins 19 project between the pins on the picker roll, while the other rows of pins are shorter, and are in line with the pins on the picker roll. This construction and arrangement results in an efficient breaking up and separation of the cotton into the individual locks, so that it may be more rapidly and efficiently operated upon by the ginning rolls. The cotton delivered by the picker roll 17 passes down through a chute 20 and is directed against the front of the ginning rolls. The inner side of the chute 20 is formed by a plate 25 which is adjustably secured to the plate 26 of the casing and covers the front side of the roll 4, so that the cotton is directed away from the front of the roll. This plate may be adjusted vertically to bring it into proper relation to the ginning and stripping rolls. The outer side of the chute 20 is provided with an adjustable plate 21 which may be adjusted toward and from the periphery of the lower roll 2, so that a space is left between the end of the plate and the roll which is large enough for the passage of seeds, but is not sufficiently large to allow the escape of the locks of cotton.

The ginning and stripping rolls may be of any suitable length, and are preferably supported at intervals by bearings, so that the machine is divided into a number of sections. When the rolls are thus supported and divided into sections, the chutes 20 for the different sections are preferably formed by a novel construction of breast plate which is shown in Figs. 5 and 6, and forms one feature of the present invention. This breast plate consists of a plate 23 extending across the

machine in front of the ginning and stripping rolls and forming the outer walls of the chutes 20. Secured to or projecting from the inner face of the plate 23 are a series of casings 24 which are arranged to embrace the bearings for the rolls, and the inner edges of which are shaped to fit against the casing plate 26 and to follow the curve of the adjustable plate 25. These casings prevent the cotton from engaging the bearings, and form the end walls of the chutes 20 for directing the cotton against the front of the ginning rolls. The breast plate with the attached casings may be readily removed when it is desired to gain access to the front of the rolls. The adjustable plates 21 are carried by the breast plate 20, and may be independently adjusted to bring them into proper relation to the ginning rolls. A delivery chute 22 is provided below each chute 20 through which the seeds are discharged after the cotton fiber has been removed therefrom.

While it is preferred to employ the specific construction and arrangement of parts shown and described, it will be understood that this construction and arrangement is not essential except so far as referred to in the claims, and may be varied and modified without departing from the broader features of the invention.

Having explained the nature and object of the invention, and specifically described one form of mechanism in which it may be embodied, what I claim is:—

1. A cotton gin, having, in combination, a rotary ginning roll, an opposed surface spaced from the roll to avoid crushing the cotton fiber and forming with the periphery of the roll a throat for ejecting the stripped seeds, and means for directing a current of air across the periphery of the roll in a direction opposite to its travel to remove the cotton drawn through the throat by the roll from the surface of the roll, substantially as described.

2. A cotton gin, having, in combination, two oppositely rotating ginning rolls having their peripheries spaced apart to avoid crushing the cotton fiber and sufficiently close to prevent seed passing between them, and means for directing a current of air across the periphery of each roll in a direction opposite to its travel to remove from the surface of the rolls the cotton drawn from the seed, substantially as described.

3. A cotton gin, having, in combination, two oppositely rotating ginning rolls spaced apart to avoid crushing the cotton and sufficiently close to prevent seed passing between them, means for directing a current of air across the periphery of each roll in a direction opposite to its travel to remove from the surface of the roll the cotton drawn from the seed, and stripping devices traveling

close to the surface of the rolls in the direction of the air currents to strip from the rolls any adhering cotton, substantially as described.

4. A cotton gin, having, in combination, two oppositely rotating ginning rolls spaced apart to avoid crushing the cotton and sufficiently close to prevent seed passing between them, stripper rolls arranged at the rear of the ginning rolls provided with cylindrical bodies forming with the peripheries of the stripper rolls restricted air passages across the peripheries of the ginning rolls and with strippers spaced from the bodies and traveling close to the surfaces of the ginning rolls, and means for producing a current of air through the passages between the ginning and stripper rolls, substantially as described.

5. A cotton gin, having, in combination, a metal ginning roll provided with a grooved surface, an oppositely rotating metal ginning roll provided with a smooth surface and spaced from the first roll to avoid crushing the cotton and sufficiently close to prevent seed passing between the rolls, a stripper roll at the rear of each ginning roll provided with a cylindrical body forming with the periphery of the corresponding ginning roll a restricted air passage across the periphery of the ginning roll and with strippers spaced from the body and traveling close to the surface of the ginning roll, and means for producing a current of air between the ginning and stripper rolls, substantially as described.

6. A cotton gin, having, in combination, two oppositely rotating ginning rolls spaced apart to avoid crushing the cotton and sufficiently close to prevent seed passing between them, two stripper rolls at the rear of the ginning rolls arranged with their peripheries close to the ginning rolls and to each other, strippers on the rolls spaced from the bodies of the rolls for the passage of air, a chute to the rear of the stripper rolls, and means for drawing air through the chute and between the stripper and ginning rolls, substantially as described.

7. A cotton gin, having, in combination, two oppositely rotating ginning rolls spaced apart to avoid crushing the cotton and sufficiently close to prevent seed passing between them, two stripper rolls at the rear of the ginning rolls arranged with their peripheries close to the ginning rolls, a chute to the rear of the stripper rolls, a condenser at the mouth of the chute, and a fan at the end of the condenser for drawing air through the condenser, through the chute, and between the stripper rolls and ginning rolls, substantially as described.

8. A cotton gin, having, in combination, ginning rolls, bearings for the rolls dividing them into sections, a plate above the

rolls, and a breast plate in front of the rolls provided with projecting casings embracing the bearings, substantially as described.

5 9. A cotton gin, having, in combination, ginning rolls, bearings for the rolls dividing them into sections, adjustable plates for the rolls, and a breast plate in front of the rolls provided with casings embracing the bearing and adjustable plates on the breast plate
10 between the casings, substantially as described.

10. A cotton gin, having, in combination, coöperating ginning rolls, stripper rolls at the rear of the ginning rolls arranged with
15 their peripheries close to the ginning rolls, a chute at the rear of the stripper rolls, and means for drawing air through the chute and between the stripper and ginning rolls, substantially as described.

20 11. A cotton gin, having, in combination, coöperating ginning rolls, stripper rolls arranged with their peripheries close to the ginning rolls and provided with pas-

sages for the flow of air between the stripper and ginning rolls within the peripheries
25 of the stripper rolls, a chute at the rear of the stripper rolls, and means for drawing air through the chute and between the stripper and ginning rolls within the peripheries of the stripper rolls, substantially as de-
30 scribed.

12. A cotton gin, having, in combination, coöperating ginning rolls, stripper rolls provided with skeleton peripheries arranged close to the stripper rolls whereby
35 air may flow between the stripper and ginning rolls within the peripheries of the stripper rolls, and means at the rear of the ginning and stripper rolls for drawing air between the ginning and stripper rolls, sub-
40 stantially as described.

JOHN J. McNALLY.

Witnesses:

N. D. McPHAIL,
GEORGE E. STEBBINS.