



US009439212B2

(12) **United States Patent**
Damnjanovic et al.

(10) **Patent No.:** **US 9,439,212 B2**

(45) **Date of Patent:** ***Sep. 6, 2016**

(54) **DYNAMIC ASSIGNMENT OF ACK RESOURCE IN A WIRELESS COMMUNICATION SYSTEM**

(58) **Field of Classification Search**
None
See application file for complete search history.

(71) Applicant: **QUALCOMM Incorporated**, San Diego, CA (US)

(56) **References Cited**
U.S. PATENT DOCUMENTS

(72) Inventors: **Aleksandar Damnjanovic**, Del Mar, CA (US); **Jelena Damnjanovic**, Del Mar, CA (US); **Juan Montojo**, San Diego, CA (US)

6,452,941 B1 9/2002 Bruhn
8,295,243 B2 10/2012 Malladi et al.
(Continued)

(73) Assignee: **QUALCOMM Incorporated**, San Diego, CA (US)

FOREIGN PATENT DOCUMENTS

(*) Notice: Subject to any disclaimer, the term of this patent is extended or adjusted under 35 U.S.C. 154(b) by 0 days.

CN 101137098 A 3/2008
EP 1349292 A2 10/2003

This patent is subject to a terminal disclaimer.

(Continued)
OTHER PUBLICATIONS

Samsung et al., UL ACK/NACK resource indication for DL persistent scheduling, Feb. 2008, 3GPP, R1-080681, all pages.*

(Continued)

(21) Appl. No.: **14/679,967**

Primary Examiner — Chirag Shah
Assistant Examiner — Srinivasa Reddivalam

(22) Filed: **Apr. 6, 2015**

(65) **Prior Publication Data**
US 2015/0215964 A1 Jul. 30, 2015

(57) **ABSTRACT**
Techniques for dynamically assigning acknowledgement (ACK) resource to a user equipment (UE) are described. For dynamic scheduling, a scheduling message may be used to send scheduling information for a single transmission of data. For semi-persistent scheduling, a scheduling message may be used to send a semi-persistent assignment for multiple transmissions of data. In an aspect, at least one field of a scheduling message, which is normally used to carry scheduling information for dynamic scheduling, may be re-used to carry an ACK resource assignment for semi-persistent scheduling. In one design, a UE may receive a scheduling message carrying a semi-persistent assignment and may obtain an assignment of ACK resource from the at least one field of the scheduling message. The UE may receive a transmission of data sent in accordance with the semi-persistent assignment, determine ACK information for the transmission of data, and send the ACK information with the ACK resource.

Related U.S. Application Data

(63) Continuation of application No. 12/403,327, filed on Mar. 12, 2009, now Pat. No. 9,036,564.

(60) Provisional application No. 61/040,609, filed on Mar. 28, 2008.

(51) **Int. Cl.**
H04W 72/12 (2009.01)
H04W 72/04 (2009.01)
(Continued)

(52) **U.S. Cl.**
CPC **H04W 72/1289** (2013.01); **H04L 1/1607** (2013.01); **H04L 1/1812** (2013.01);
(Continued)

34 Claims, 10 Drawing Sheets

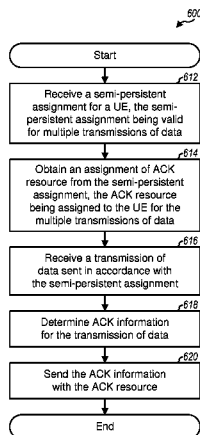

- (51) **Int. Cl.**
H04L 1/16 (2006.01)
H04L 1/00 (2006.01)
H04L 1/18 (2006.01)
H04L 5/00 (2006.01)
H04L 25/03 (2006.01)
- (52) **U.S. Cl.**
 CPC *H04L1/1861* (2013.01); *H04L 5/0053*
 (2013.01); *H04L 5/0091* (2013.01); *H04W*
72/042 (2013.01); *H04L 1/0028* (2013.01);
H04L 1/1819 (2013.01); *H04L 5/0007*
 (2013.01); *H04L 5/0062* (2013.01); *H04L*
5/0064 (2013.01); *H04L 25/03866* (2013.01)

(56) **References Cited**

U.S. PATENT DOCUMENTS

2006/0205414	A1 *	9/2006	Teague	455/452.1
2007/0097981	A1	5/2007	Papasakellariou	
2008/0117891	A1	5/2008	Damnjanovic et al.	
2009/0109906	A1	4/2009	Love et al.	
2009/0109912	A1	4/2009	DiGirolamo et al.	
2009/0138598	A1	5/2009	Shrivastava et al.	
2009/0238128	A1 *	9/2009	Park et al.	370/329
2009/0245194	A1	10/2009	Damnjanovic et al.	
2011/0256879	A1 *	10/2011	Chun	H04W 72/042 455/450
2015/0078306	A1 *	3/2015	Meyer	H04L 1/1812 370/329

FOREIGN PATENT DOCUMENTS

RU	2231227	6/2004
WO	WO 2008/024788 A2 *	2/2008
WO	WO-2008024788 A2	2/2008
WO	WO-2008024890 A2	2/2008

OTHER PUBLICATIONS

Ericsson et al., "Control of semi persistent scheduling", TSG-RAN WG2 Meeting #61, R2-080765, Sorrento, Italy, Feb. 11-15, 2008.
 Ericsson, "R2-062859: Semi Persistent Scheduling," Oct. 2006, pp. 1-15, Internet Citation, XP002496512.
 European Search Report—EP11159602—Search Authority—The Hague —Apr. 5, 2011.

European Search Report—EP13158370—Search Authority—The Hague—Jul. 18, 2013.
 Fredrik Persson: "Voice over IP Realized for the 3GPP Long Term Evolution" IEEE Vehicular Technology Conference, Sep. 1, 2007, pp. 1436-1440, XP031147644 IEEE, PI ISBN: 978-1-4244-0263-2 abstract sections V.C, V.E, VII, VIII.
 Huawei: "Relation between UL ACK/NACK and DL CCE" 3GPP Draft; R1-074063, 3rd Generation Partnership Project (3GPP), Mobile Competence Centre ; 650, Route Des Lucioles ; F-06921 Sophia-Antipolis Cedex; France, vol. RAN WG1, no. Shanghai, China; 20071002, Oct. 2, 2007, XP050107604.
 International Search Report & Written Opinion—PCT/US2009/038656, International Search Authority—European Patent Office—Jun. 1, 2010.
 Motorola, "E-UTRA Uplink L1/L2 Control Channel Mapping", 3GPP Draft; R1-062626 UL L1 L2 Control Mapping, 3rd Generation Partnership Project (3GPP), Mobile Competence Centre; 650, Route Des Lucioles; F-06921 Sophia-Antipolis Cedex; Francia, vol. RAN WG1, no. Seoul, Corea; 20061004, Oct. 4, 2006, XP050103126.
 Nokia et al: "PHICH and mapping to PHICH groups" 3GPP Draft; R1-080927, 3rd Generation Partnership Project (3GPP), vol. RAN WG1, no. Sorrento, Italy; 20080206, Feb. 6, 2008, XP050109400, Mobile Competence Centre; 650, Route Des Lucioles; F-06921 Sophia-Antipolis Cedex; France, figures 1-3 sections 2, 3.
 NTT DoCoMo, Inc., "UL ACK/NACK resource allocation for DL semi-persistent scheduling", 3GPP TSG RAN WG2 Meeting #61bis, R2-081857, pp. 1-4, Apr. 4, 2008.
 Partial Search Report—PCT/US2009/038656—International Search Authority—European Patent Office, Apr. 9, 2010.
 Philips, et al., "Control of E-UTRAN UL Scheduling", 3GPP TSG RAN WG2 Meeting #59bis, R2-074355, pp. 1-4, Oct. 12, 2007.
 Qualcomm Europe, "Details on Semi-Persistent Scheduling Activation with Single PDCCH", 3GPP TSG RAN WG1 Meeting #53bis, R1-082542, pp. 1-6, Jun. 30-Jul. 4, 2008.
 Qualcomm Europe: "Details on UL Power Control", 3GPP, TSG-RAN WG1 #50-bis, R1-073930, pp. 1-4.
 Samsung et al., "UL ACK/NACK resource indication for DL persistent scheduling", 3GPP Draft; R1-080681 UL Persistent ACKNACK Indication and Use, 3rd Generation Partnership Project (3GPP), Mobile Competence Centre ; 650, Route Des Lucioles ; F-06921 Sophia-Antipolis Cedex; France, vol. RAN WG1, no. Sorrento, Italy; 20080205 Feb. 5, 2008, XP050109177, [retrieved on Feb. 5, 2008].
 Taiwan Search Report—TW098110445—TIPO—Jan. 26, 2013.

* cited by examiner

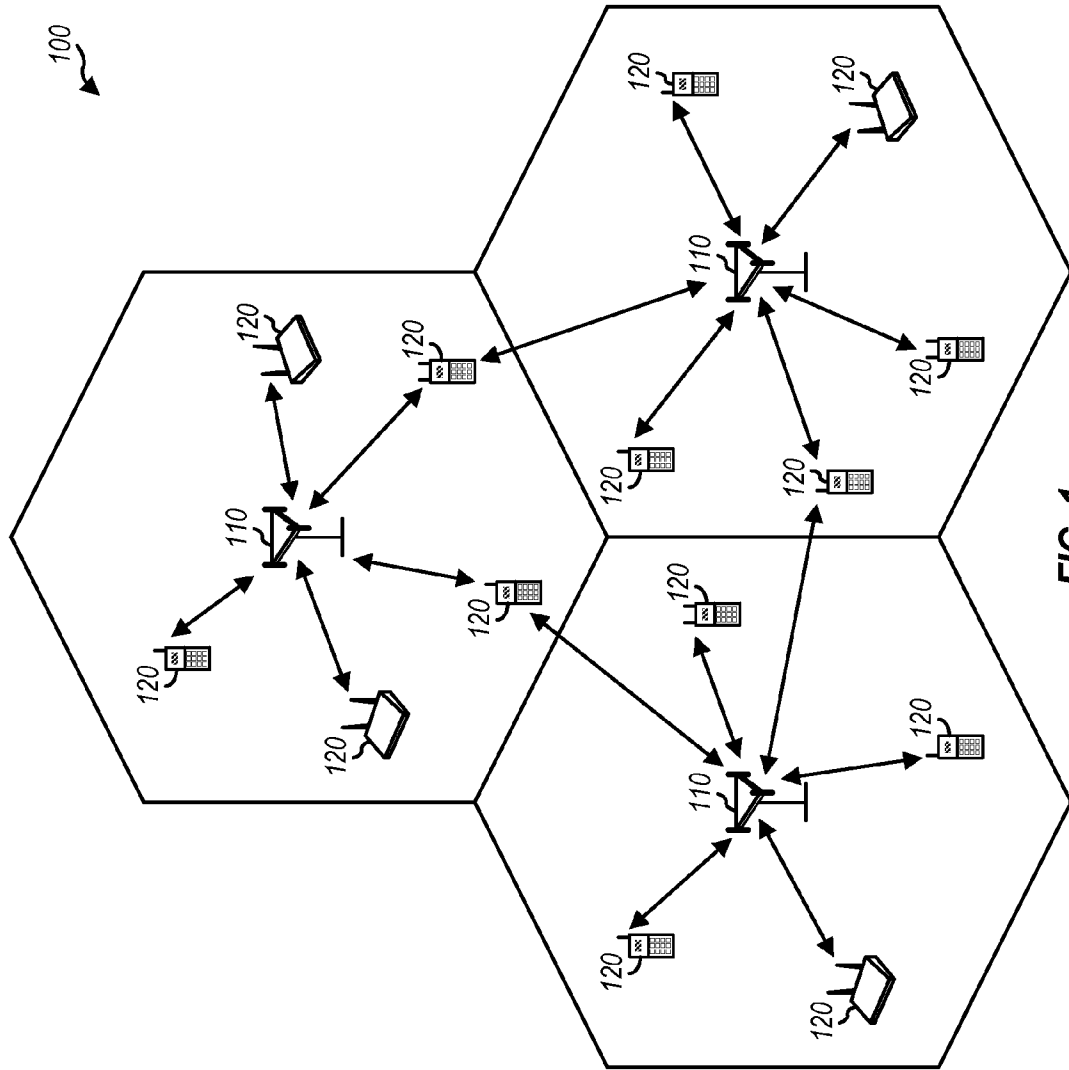

FIG. 1

Data Transmission with Dynamic Scheduling

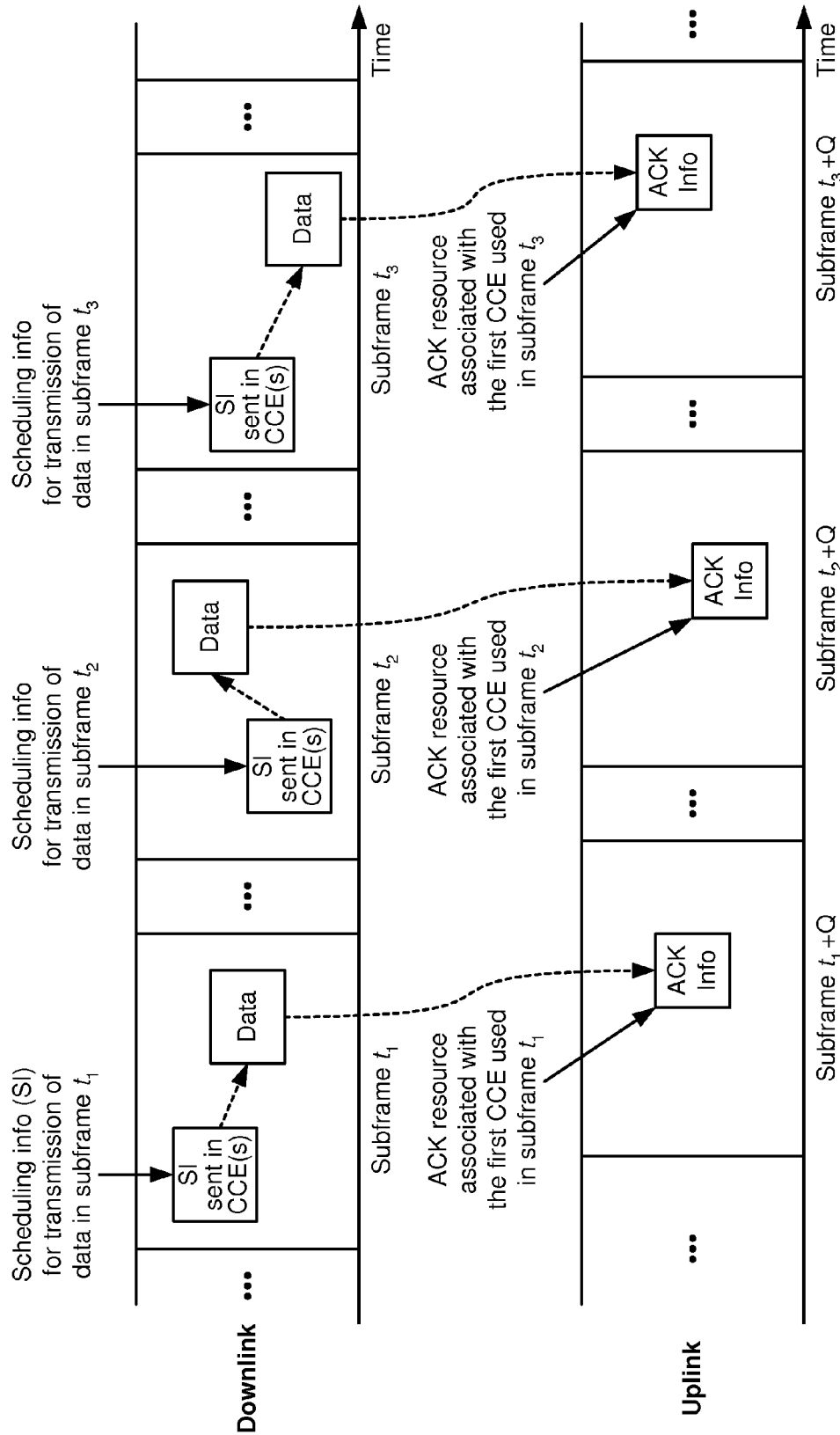

FIG. 2

Data Transmission with Semi-Persistent Scheduling

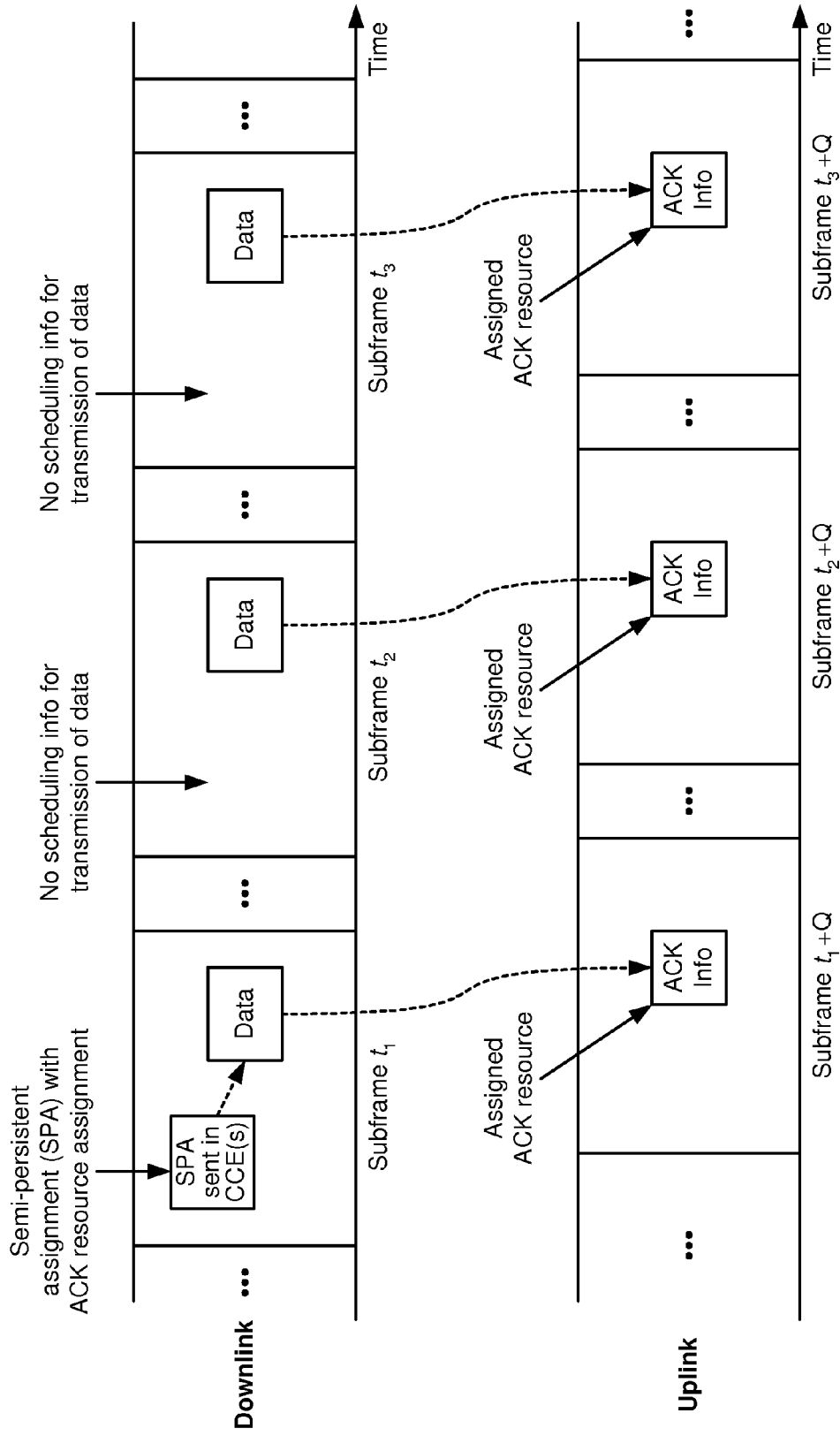

FIG. 3

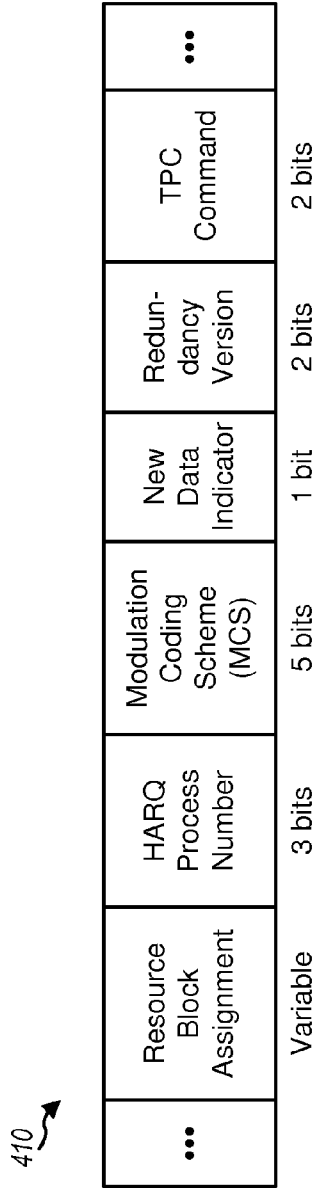

FIG. 4A

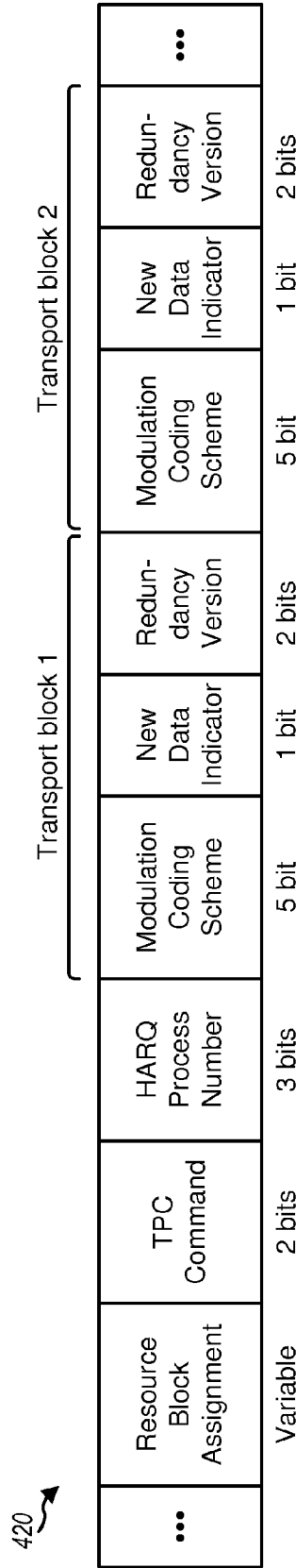

FIG. 4B

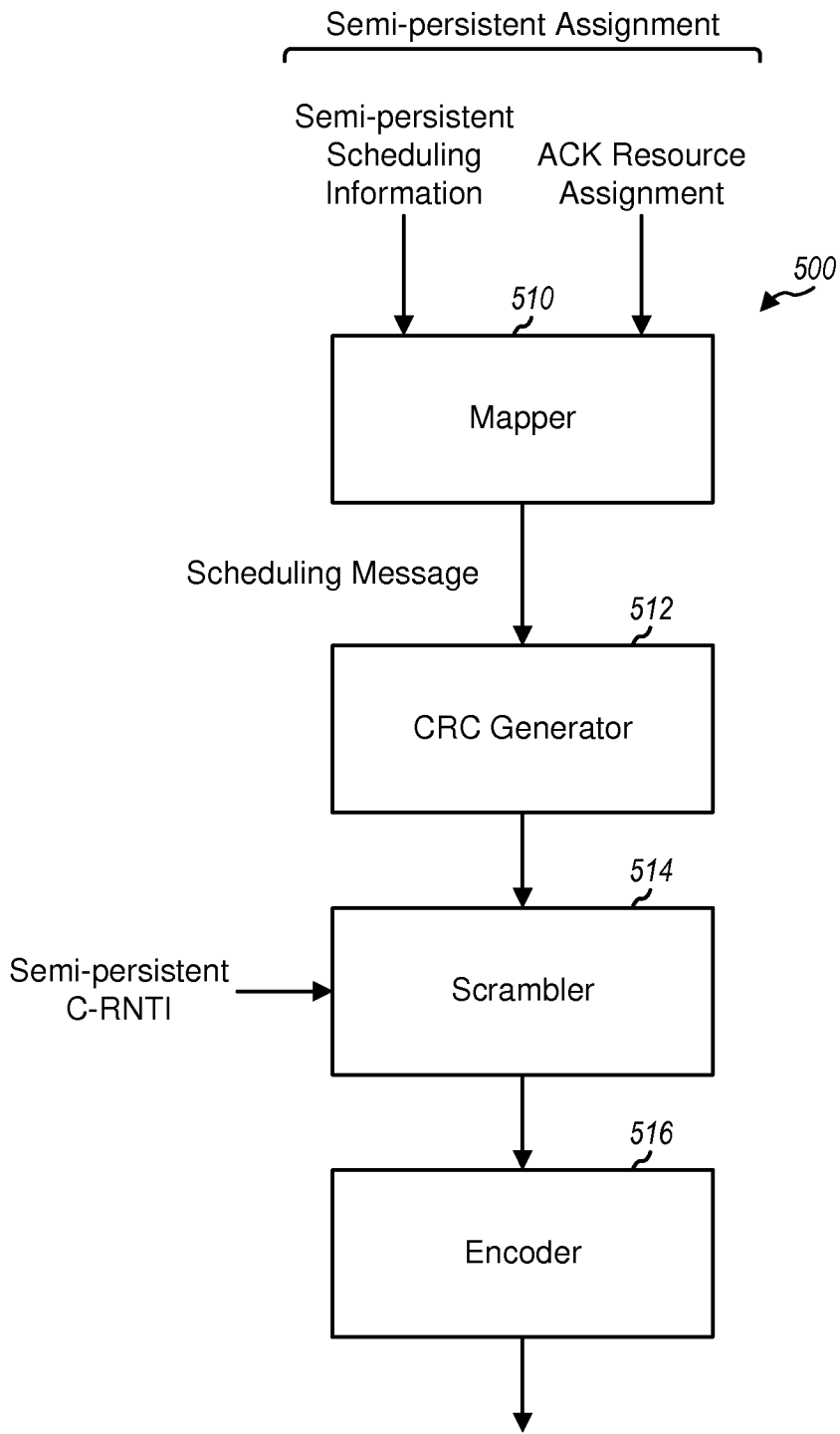

FIG. 5

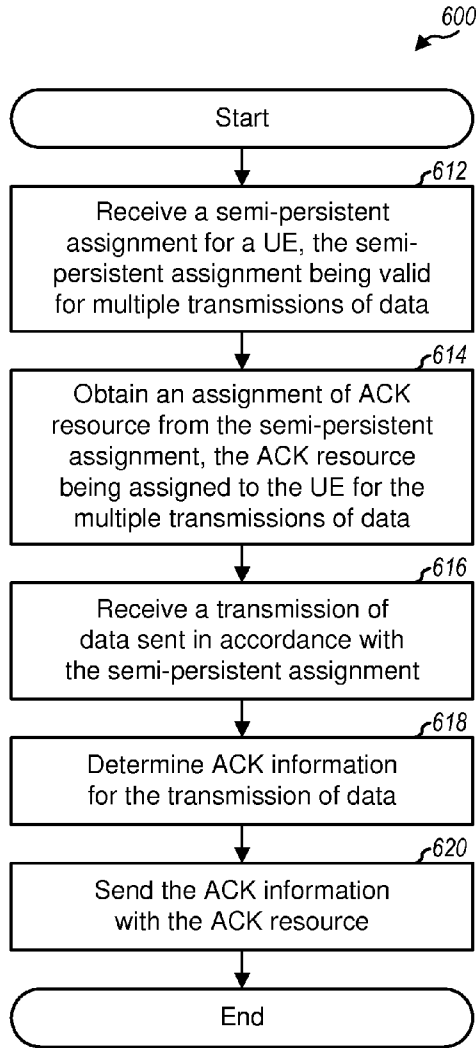

FIG. 6

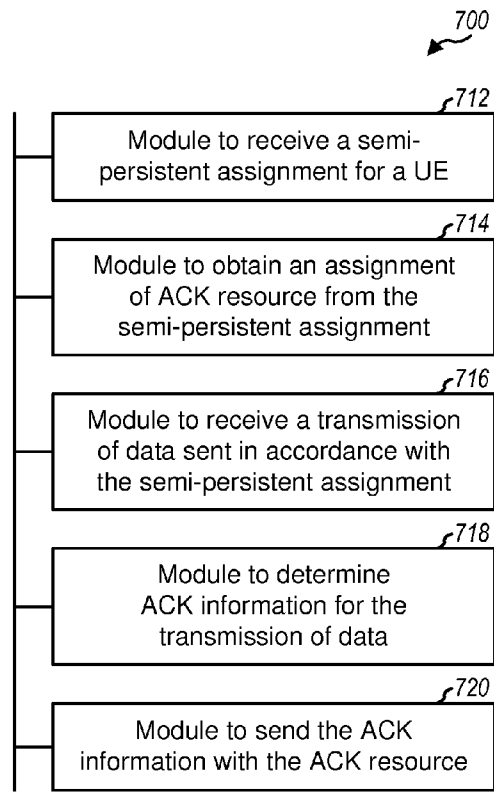

FIG. 7

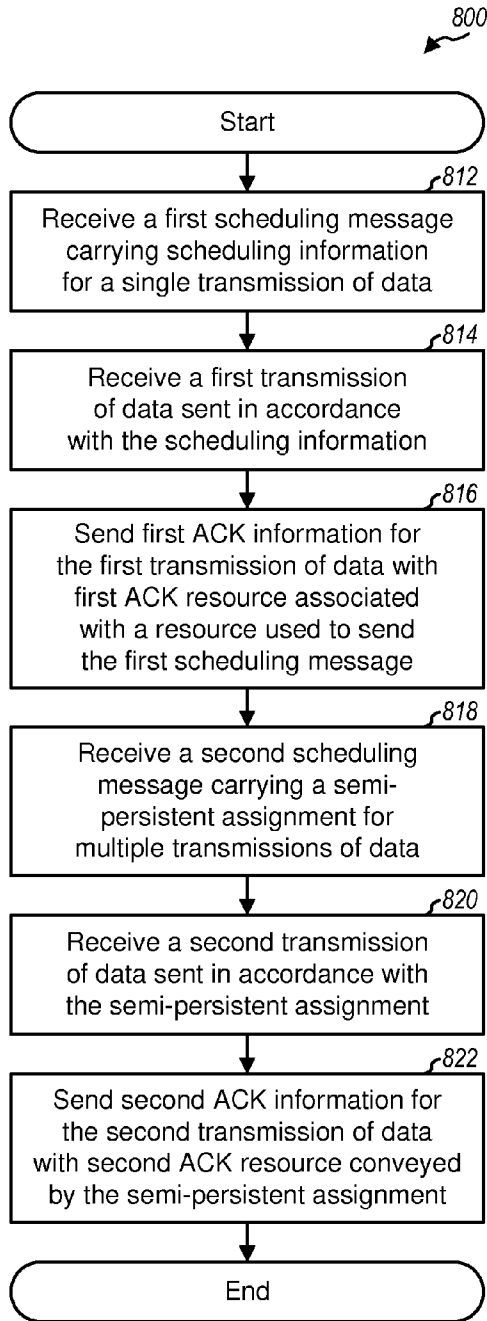

FIG. 8

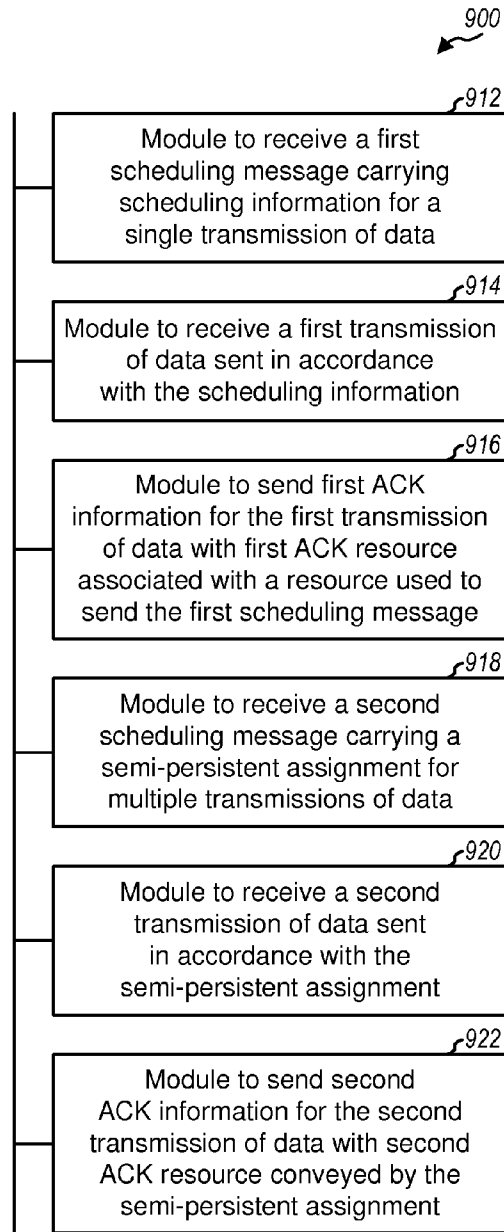

FIG. 9

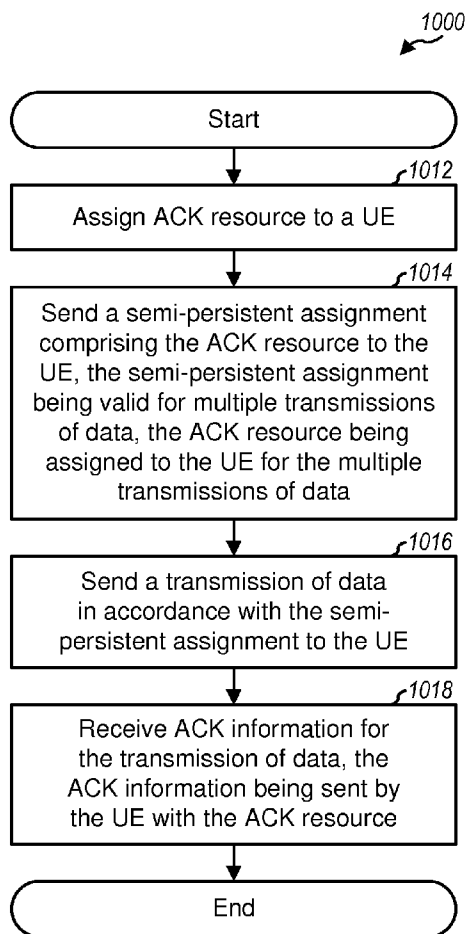

FIG. 10

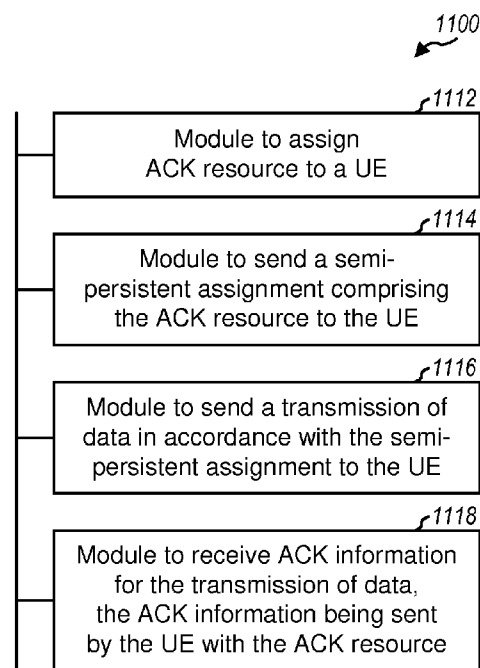

FIG. 11

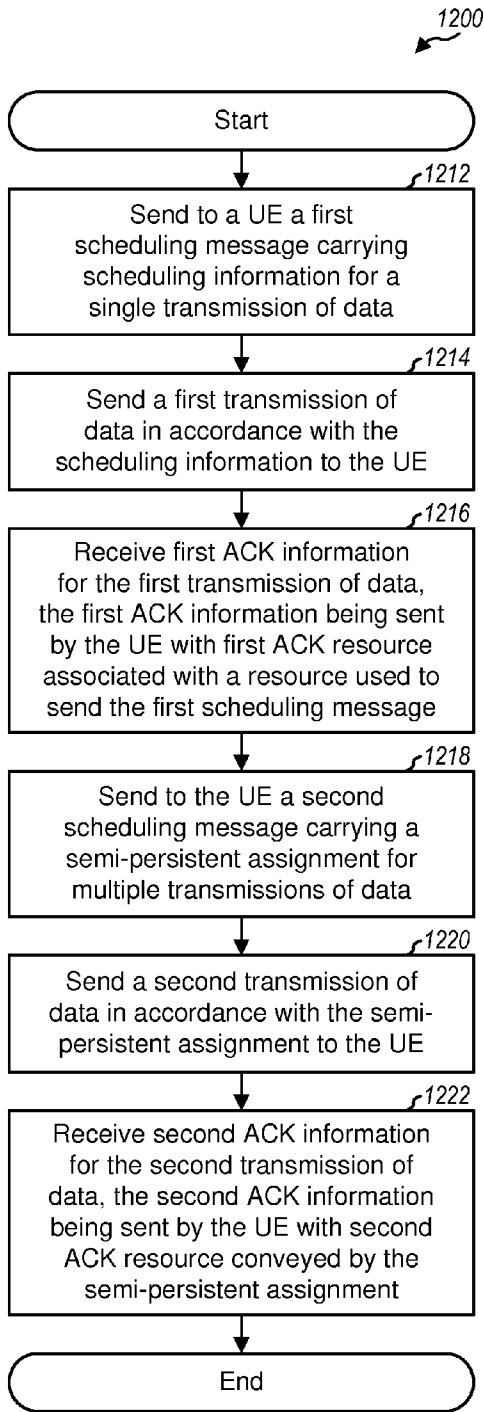

FIG. 12

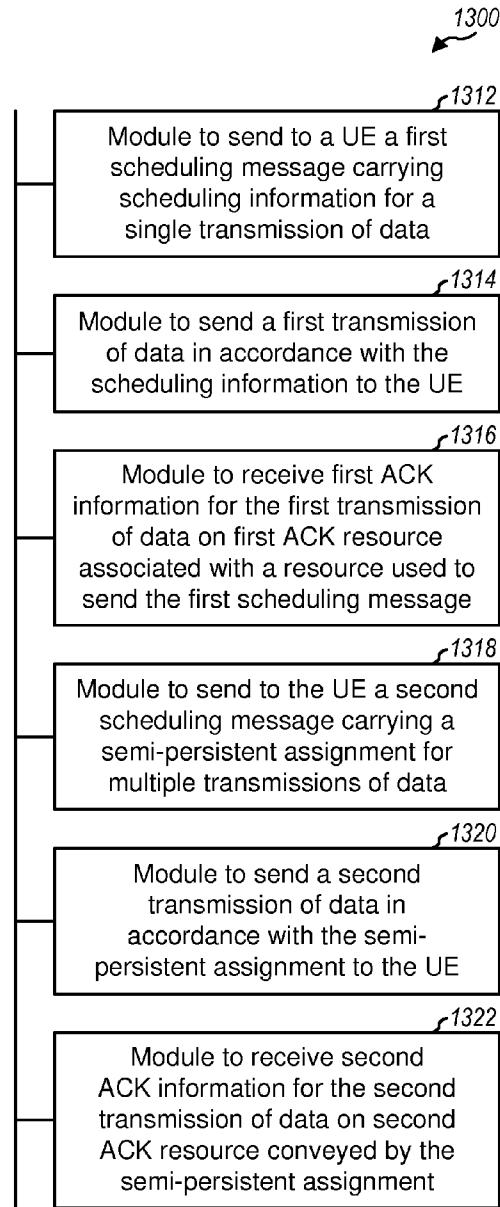

FIG. 13

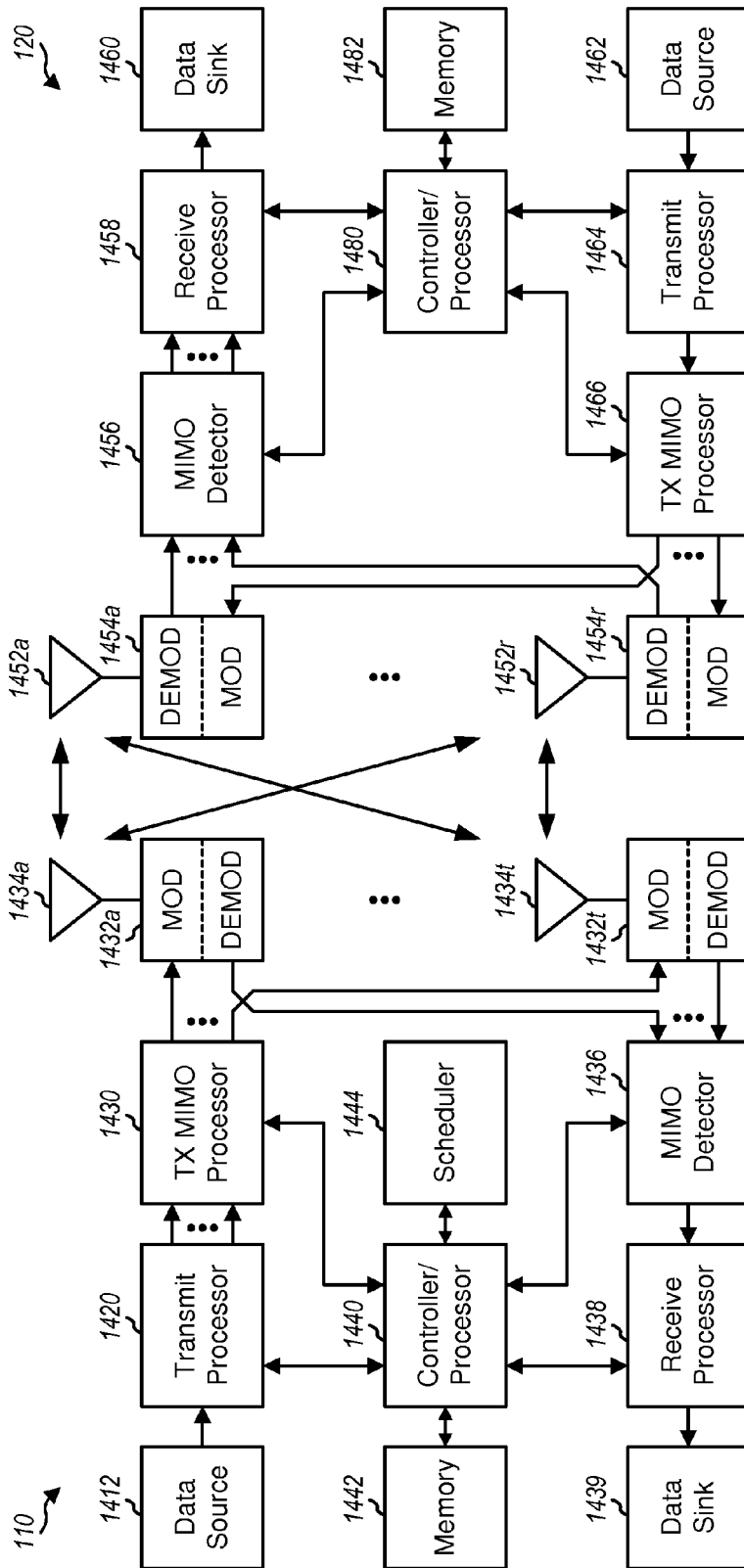

FIG. 14

DYNAMIC ASSIGNMENT OF ACK RESOURCE IN A WIRELESS COMMUNICATION SYSTEM

The present application is a Continuation application of U.S. Ser. No. 12/403,327 filed Mar. 12, 2009, entitled "Dynamic Assignment Of ACK Resource In A Wireless Communication System," which claims priority to provisional U.S. Application Ser. No. 61/040,609, entitled "Dynamic Scheduling of UL-ACK," filed Mar. 28, 2008, assigned to the assignee hereof and incorporated herein by reference.

BACKGROUND

I. Field

The present disclosure relates generally to communication, and more specifically to techniques for assigning resources in a wireless communication system.

II. Background

Wireless communication systems are widely deployed to provide various communication content such as voice, video, packet data, messaging, broadcast, etc. These wireless systems may be multiple-access systems capable of supporting multiple users by sharing the available system resources. Examples of such multiple-access systems include Code Division Multiple Access (CDMA) systems, Time Division Multiple Access (TDMA) systems, Frequency Division Multiple Access (FDMA) systems, Orthogonal FDMA (OFDMA) systems, and Single-Carrier FDMA (SC-FDMA) systems.

A wireless communication system may include a number of Node Bs that can support communication for a number of user equipments (UEs). A Node B may communicate with a UE on the downlink and uplink. The downlink (or forward link) refers to the communication link from the Node B to the UE, and the uplink (or reverse link) refers to the communication link from the UE to the Node B. The Node B may send a transmission of data to the UE. The UE may decode the transmission of data and may send acknowledgement (ACK) information to the Node B. The ACK information may indicate whether the transmission of data was decoded correctly or in error by the UE. The Node B may determine whether to send a retransmission of data or a new transmission of data to the UE based on the ACK information. It may be desirable to efficiently assign ACK resource to the UE for use to send the ACK information.

SUMMARY

Techniques for dynamically assigning ACK resource to a UE in a wireless communication system are described herein. The system may support dynamic scheduling and semi-persistent scheduling. For dynamic scheduling, a scheduling message may be used to send scheduling information for a single transmission of data. For semi-persistent scheduling, a scheduling message may be used to send a semi-persistent assignment for multiple transmissions of data.

In an aspect, at least one field of a scheduling message, which is normally used to carry scheduling information for dynamic scheduling, may be re-used to carry an ACK resource assignment for semi-persistent scheduling. The at least one field may include a new data indicator field, a redundancy version field, a modulation and coding scheme (MCS) field, a transmit power control (TPC) command field, etc.

In one design, a UE may receive a scheduling message carrying a semi-persistent assignment and may obtain an assignment of ACK resource from the semi-persistent assignment. The UE may obtain an index of the ACK resource from at least one field of the scheduling message and may determine the ACK resource based on the index. The UE may receive a transmission of data sent in accordance with the semi-persistent assignment, determine ACK information for the transmission of data, and send the ACK information with the ACK resource.

In another design, a UE may receive a first scheduling message carrying scheduling information for dynamic scheduling and may receive a first transmission of data sent in accordance with the scheduling information. The UE may send ACK information for the first transmission of data with first ACK resource associated with a resource used to send the first scheduling message. The UE may receive a second scheduling message carrying a semi-persistent assignment for semi-persistent scheduling. The UE may receive a second transmission of data sent in accordance with the semi-persistent assignment. The UE may send ACK information for the second transmission of data with second ACK resource conveyed by the semi-persistent assignment. ACK resources may thus be conveyed in different manners for dynamic scheduling and semi-persistent scheduling.

Various aspects and features of the disclosure are described in further detail below.

BRIEF DESCRIPTION OF THE DRAWINGS

FIG. 1 shows a wireless communication system.

FIG. 2 shows data transmission with dynamic scheduling.

FIG. 2 shows data transmission with semi-persistent scheduling.

FIGS. 4A and 4B show two scheduling messages with different formats.

FIG. 5 shows a processing unit for a scheduling message.

FIGS. 6 and 7 show a process and an apparatus, respectively, for receiving data with semi-persistent scheduling.

FIGS. 8 and 9 show a process and an apparatus, respectively, for receiving data with dynamic scheduling and semi-persistent scheduling.

FIGS. 10 and 11 show a process and an apparatus, respectively, for sending data with semi-persistent scheduling.

FIGS. 12 and 13 show a process and an apparatus, respectively, for sending data with dynamic scheduling and semi-persistent scheduling.

FIG. 14 shows a block diagram of a Node B and a UE.

DETAILED DESCRIPTION

The techniques described herein may be used for various wireless communication systems such as CDMA, TDMA, FDMA, OFDMA, SC-FDMA and other systems. The terms "system" and "network" are often used interchangeably. A CDMA system may implement a radio technology such as Universal Terrestrial Radio Access (UTRA), cdma2000, etc. UTRA includes Wideband CDMA (WCDMA) and other variants of CDMA. cdma2000 covers IS-2000, IS-95 and IS-856 standards. A TDMA system may implement a radio technology such as Global System for Mobile Communications (GSM). An OFDMA system may implement a radio technology such as Evolved UTRA (E-UTRA), Ultra Mobile Broadband (UMB), IEEE 802.11 (Wi-Fi), IEEE 802.16 (WiMAX), IEEE 802.20, Flash-OFDM®, etc. UTRA and E-UTRA are part of Universal Mobile Telecom-

munication System (UMTS). 3GPP Long Term Evolution (LTE) is an upcoming release of UMTS that uses E-UTRA, which employs OFDMA on the downlink and SC-FDMA on the uplink. UTRA, E-UTRA, UMTS, LTE and GSM are described in documents from an organization named "3rd Generation Partnership Project" (3GPP). cdma2000 and UMB are described in documents from an organization named "3rd Generation Partnership Project 2" (3GPP2). The techniques described herein may be used for the systems and radio technologies mentioned above as well as other systems and radio technologies. For clarity, certain aspects of the techniques are described below for LTE, and LTE terminology is used in much of the description below.

FIG. 1 shows a wireless communication system 100, which may be an LTE system. System 100 may include a number of Node Bs 110 and other network entities. A Node B may be a station that communicates with the UEs and may also be referred to as an evolved Node B (eNB), a base station, an access point, etc. UEs 120 may be dispersed throughout the system, and each UE may be stationary or mobile. A UE may also be referred to as a mobile station, a terminal, an access terminal, a subscriber unit, a station, etc. A UE may be a cellular phone, a personal digital assistant (PDA), a wireless modem, a wireless communication device, a handheld device, a laptop computer, a cordless phone, a wireless local loop (WLL) station, etc.

The system may support data transmission with hybrid automatic retransmission (HARQ). For HARQ on the downlink, a Node B may send a transmission of a transport block and may send one or more additional transmissions of the transport block (if needed) until the transport block is decoded correctly by a recipient UE, or the maximum number of transmissions has been sent, or some other termination condition is encountered. A transport block may also be referred to as a packet, a data block, etc. The first transmission of a transport block may be referred to as a new transmission, and each additional transmission of the transport block may be referred to as a retransmission.

The system may also support dynamic scheduling and semi-persistent scheduling for data transmission. For dynamic scheduling, scheduling information may be sent with each transmission of data and may convey parameters and resources used for that transmission of data. For semi-persistent scheduling, scheduling information may be sent once and may be applicable for multiple transmissions of data. Dynamic scheduling may provide flexibility whereas semi-persistent scheduling may reduce signaling overhead.

FIG. 2 shows an exemplary data transmission on the downlink with dynamic scheduling. The transmission timeline for each link may be partitioned into units of subframes. Each subframe may have a particular duration, e.g., one millisecond (ms). For frequency division duplexing (FDD) as shown in FIG. 2, the downlink (DL) and uplink (UL) may be allocated separate frequency channels. Different transmissions may be sent concurrently via the downlink and uplink on the separate frequency channels. A Node B may have data to send to a UE and may send scheduling information on a physical downlink control channel (PDCCH) in subframe t_1 . The scheduling information may be sent in one or more control channel elements (CCEs) and may include various parameters described below. The Node B may send a transmission of one or more transport blocks on a physical downlink shared channel (PDSCH) in subframe t_1 . The Node B may send the transport block(s) in one or more resource blocks and in accordance with parameters conveyed by the scheduling information. The UE may receive the scheduling information from the PDCCH and

may process the transmission on the PDSCH in accordance with the scheduling information to recover the transport block(s) sent by the Node B. The UE may generate ACK information (or UL-ACK), which may indicate whether each transport block was decoded correctly or in error by the UE. The UE may send the ACK information on a physical uplink control channel (PUCCH) in subframe t_1+Q , where Q may be equal to 2, 4 or some other value. Q is a subframe offset between the data transmission on the downlink and the corresponding ACK transmission on the uplink. The Node B may receive the ACK information from the UE and may send a retransmission of each transport block decoded in error.

The UE may send the ACK information with ACK resource, which may also be referred to as PUCCH resource, ACK channel, etc. The ACK resource may be associated with radio resource, code resource (e.g., an orthogonal sequence, a reference signal sequence, etc.), and/or other resources used to send ACK information. For example, in LTE, the ACK resource may be given by an ACK index $n(1)_{PUCCH}$ and may be associated with (i) a time-frequency location (e.g., a resource block) on which to send ACK information, (ii) a cyclic shift of a Zadoff-Chu sequence used for spreading the ACK information in the frequency domain, and (iii) an orthogonal or Walsh spreading sequence used for spreading the ACK information in the time domain.

For dynamic scheduling, the ACK resource to use by the UE may be determined as follows:

$$n_{PUCCH} = n_{CCE} + N_{PUCCH} \quad \text{Eq. (1)}$$

where

n_{CCE} is an index of the first CCE used to send scheduling information,

n_{PUCCH} is an index of the ACK resource, and

N_{PUCCH} is a parameter configured by higher layers.

N_{PUCCH} may be configured by Radio Resource Control (RRC) and broadcast to UEs. For dynamic scheduling, the ACK resource may be linked to the first CCE carrying the scheduling information, e.g., as shown in equation (1). The ACK resource may thus be implicitly conveyed via the scheduling information, and no additional overhead is consumed to send the ACK resource assignment to the UE.

For dynamic scheduling, each transmission of data may occur as described above. For each transmission of data, the Node B may send scheduling information in one or more CCEs and may send a transmission of one or more transport blocks in one or more resource blocks conveyed by the scheduling information. The UE may send ACK information with the ACK resource determined based on the first CCE carrying the scheduling information.

FIG. 3 shows an exemplary data transmission on the downlink with semi-persistent scheduling. A Node B may send a semi-persistent assignment or grant on the PDCCH in subframe t_1 . The semi-persistent assignment may include various parameters for transmissions of data on the downlink as well as an ACK resource assignment for the uplink. In one design, upper layers (e.g., RRC) may configure a set of ACK resources, and the ACK resource assignment may comprise an index for an ACK resource in the set of configured ACK resources. In another design, the ACK resource assignment may assign any available ACK resource.

The Node B may send a transmission of one or more transport blocks on the PDSCH in subframe t_1 . The Node B may send the transport block(s) in one or more resource blocks and in accordance with parameters conveyed by the

5

semi-persistent assignment. The UE may receive the semi-persistent assignment from the PDCCH and may process the transmission on the PDSCH in accordance with the semi-persistent assignment to recover the transport block(s) sent by the Node B. The UE may generate ACK information for the transport block(s) and may send the ACK information in subframe t_1+Q . The ACK information may be sent with the ACK resource conveyed by the semi-persistent assignment.

For semi-persistent scheduling, the semi-persistent assignment may be sent once with the first transmission of data and may be valid for a predetermined time period or until the semi-persistent assignment is revoked. The ACK resource assignment would be valid for the entire semi-persistent scheduling interval, which is the duration in which the semi-persistent assignment is valid. The Node B may send new transmissions of data in accordance with the semi-persistent assignment, without having to send any scheduling information, during the semi-persistent scheduling interval. The UE may send ACK information for each new transmission of data received from the Node B using the ACK resource provided by the semi-persistent assignment. For example, the Node B may send new transmissions at a periodic rate in subframes t_1 , $t_2=t_1+M$, $t_3=t_1+2M$, . . . , and $t_L=t_1+L\cdot M$, where parameters M and L and/or the semi-persistent scheduling interval may be configured. For example, in LTE, parameter M may be configured by upper layers (e.g., RRC). The UE may send ACK information in corresponding subframes t_1+Q , t_2+Q , t_3+Q , . . . , and t_L+Q with the assigned ACK resource.

The Node B may also send retransmissions of data during the semi-persistent scheduling period and may send scheduling information for each retransmission of data, e.g., in the same manner as for dynamic scheduling. The UE may send ACK information for each retransmission of data with the ACK resource associated with the first CCE carrying the scheduling information for that retransmission.

In an aspect, an ACK resource assignment for semi-persistent scheduling may be sent by re-using at least one existing field of a scheduling message. The scheduling message may include a number of fields to carry scheduling information for dynamic scheduling. To simplify operation, the scheduling message may also be used to send a semi-persistent assignment for semi-persistent scheduling. At least one field normally used to carry scheduling information for dynamic scheduling may be re-used to carry an ACK resource assignment for semi-persistent scheduling.

Various formats may be defined for the scheduling message and may be applicable for different operating scenarios. Each format may include a specific set of fields for a set of parameters for scheduling information.

FIG. 4A shows a scheduling message 410 in accordance with Formats 1 and 1A defined by LTE. Formats 1 and 1A may be used to schedule transmission of one transport block on the PDSCH. Message 410 includes a resource block assignment field, an HARQ process number field, a modulation and coding scheme (MCS) field, a new data indicator field, a redundancy version field, and a transmit power control (TPC) command field. The redundancy version field and the new data indicator field may be considered as belonging in a retransmission sequence number field. Message 410 may also include other fields, which are not shown in FIG. 4A for simplicity.

For HARQ, a number of HARQ processes may be defined. Each HARQ process may be used to send a new transmission and all retransmissions of a transport block. An HARQ process may be started for a transport block if the HARQ process is available and may terminate when the

6

transport block is decoded correctly. The transport block may be encoded in accordance with an MCS selected for the transport block to obtain a codeword. The codeword may be partitioned into multiple redundancy versions, and each redundancy version may contain different encoded information (or code bits) for the transport block. A Node B may select one redundancy version to send for a transmission of the transport block.

Table 1 lists the fields of scheduling message 410 and provides a short description for each field. Table 1 also gives the size of each field in number of bits.

TABLE 1

Scheduling Message		
Fields	Size	Description
Resource block assignment	variable	Indicate resource block(s) used to send a transport block.
HARQ process number	3 bits	Indicate HARQ process on which the transport block is sent.
Modulation and coding scheme	5 bits	Indicate modulation scheme and code rate for the transport block.
New data indicator	1 bit	Indicate whether the current transmission is a retransmission of the transport block.
Redundancy version	2 bits	Indicate redundancy version being sent for the transport block.
TPC command	2 bits	Indicate transmit power adjustment for the PUCCH sent by a recipient UE.

FIG. 4B shows a scheduling message 420 in accordance with Formats 2 and 2A defined by LTE. Formats 2 and 2A may be used to schedule a transmission of one or two transport blocks on the PDSCH in a spatial multiplexing mode. Message 420 includes a resource block assignment field, a TPC command field, an HARQ process number field, and two sets of fields for two transport blocks. Each set includes an MCS field, a new data indicator field, and a redundancy version field. Message 420 may also include other fields, which are not shown in FIG. 4B for simplicity. The fields in message 420 are described in Table 1.

FIGS. 4A and 4B show two formats that may be used for sending scheduling information. Other formats may also be used and may include different fields than those shown in FIGS. 4A and 4B. For clarity, much of the description below refers to scheduling messages 410 and 420.

For dynamic scheduling, message 410 or 420 may be used to send scheduling information for a transmission of data. A suitable scheduling message may be selected based on whether one or multiple transport blocks are sent and/or other considerations. For semi-persistent scheduling, message 410 or 420 may be used to send a semi-persistent assignment with the first transmission of data. At least one field of message 410 or 420 may be used to send an ACK resource assignment. In general, any field(s) may be used to send the ACK resource assignment. However, it may be desirable to select a field that is not relevant (or not as relevant) for semi-persistent scheduling. For example, a field that may be less applicable for the first transmission of data and/or may have little adverse effect on performance may be selected. The number of fields to select may be dependent on the number of bits needed to send the ACK resource assignment.

In one design, an ACK resource assignment may be sent in the new data indicator field, the redundancy version field, and the TPC command field. In the design shown in FIGS. 4A and 4B, five bits are available for these three fields. Up to 32 ACK resources may be configured or defined and assigned indices of 0 to 31. The configured ACK resources

may be broadcast to the UEs or known a priori by the UEs. A 5-bit ACK resource index for one of up to 32 possible ACK resources may be sent in the three fields to a UE. The UE may obtain the ACK resource index from the three fields and may determine the ACK resource assigned to the UE based on the ACK resource index and the configured ACK resources. The UE may use the ACK resource to send ACK information during the semi-persistent scheduling period.

In another design, an ACK resource assignment may be sent in the new data indicator field, the redundancy version field, the TPC command field and all or a subset of the MCS field. For example, two bits in the MCS field may be used in conjunction with the five bits from the other three fields. Up to 128 ACK resources may then be configured with the seven bits in the four fields. A 7-bit ACK resource index for one of up to 128 configured ACK resources may be sent in the four fields to a UE. The MCS field can normally convey one of up to 32 MCS values for dynamic scheduling. A set of 8 MCS values may be supported for semi-persistent scheduling and may be configured by higher layers, e.g., RRC. One MCS value may be selected from the set of 8 MCS values and may be conveyed with three remaining bits in the MCS field. As another example, up to 64 ACK resources may be configured with five bits in the three fields and one bit in the MCS field. A set of 16 MCS values may be supported for semi-persistent scheduling, and one MCS value may be selected and conveyed with four remaining bits in the MCS field.

In yet another design, an ACK resource assignment may be sent using two bits in the new data indicator field and the redundancy version field, one bit in the TPC command field, and three bits in the MCS field. Up to 64 ACK resources may be configured with the six bits in the four fields. A 6-bit ACK resource index for one of up to 64 configured ACK resources may be sent using the six bits in the four fields to a UE. In yet another design, an ACK resource assignment may be sent in the TPC command field. Two bits are available in the TPC command field. Hence, up to four ACK resources may be configured and assigned indices of 0 to 3. A 2-bit ACK resource index for one of up to four configured ACK resources may be sent in the TPC command field to a UE.

In general, any combination of fields and/or bits may be used to send an ACK resource assignment for semi-persistent scheduling. If N bits are available to send the ACK resource assignment, then up to 2^N ACK resources may be configured (e.g., by RRC) and may be assigned indices of 0 through $2^N - 1$. The configured ACK resources may be broadcast to the UEs or known a priori by the UEs. An N -bit ACK resource index for an assigned ACK resource may be sent using the N available bits.

A scheduling message may carry scheduling information for dynamic scheduling or a semi-persistent assignment for semi-persistent scheduling. Various mechanisms may be used to indicate whether the scheduling message is sent for dynamic scheduling or semi-persistent scheduling. In one design, different scrambling mechanisms may be used for the scheduling message for dynamic scheduling and semi-persistent scheduling. In another design, the scheduling message may include a special bit to indicate whether the message is for dynamic scheduling or semi-persistent scheduling. In yet another design, a designated cell radio network temporary identifier (C-RNTI), which may be referred to as a semi-persistent C-RNTI, may be used to indicate a semi-persistent assignment. Each UE in a given cell may be assigned a unique C-RNTI for use as a UE identity for that cell. Each UE that has semi-persistent scheduling enabled may also be assigned a unique semi-persistent C-RNTI. A

Node B may send a scheduling message to a specific UE for dynamic scheduling by using the normal C-RNTI for the UE or for semi-persistent scheduling by using the semi-persistent C-RNTI for the UE. Each UE may detect for scheduling messages from the Node B with the normal C-RNTI for that UE. Each UE that has semi-persistent scheduling enabled may also detect for scheduling messages with the semi-persistent C-RNTI for that UE. In one design, unused fields and/or unused bits in a scheduling message for semi-persistent scheduling may be set to designated values. For example, the new data indicator field, the HARQ process number field, and the redundancy version field of the scheduling message may be set to designated values of all zeros for semi-persistent scheduling. The designated values may be used by a recipient UE to validate the scheduling message as being for semi-persistent scheduling for that UE (instead of dynamic scheduling for another UE).

FIG. 5 shows a block diagram of a design of a processing unit 500 for generating and processing a scheduling message for semi-persistent scheduling. Within processing unit 500, a mapper 510 may receive a semi-persistent assignment comprising semi-persistent scheduling information (e.g., a resource block assignment, an MCS, etc.) and an ACK resource assignment for a UE. Mapper 510 may map the ACK resource assignment to at least one field of a scheduling message and may map the scheduling information to remaining fields and bits of the scheduling message. Mapper 510 may also set unused fields and/or unused bits of the scheduling message to designated values (e.g., all zeros). A cyclic redundancy check (CRC) generator 512 may receive the scheduling message from mapper 510, generate a CRC for the message, and append the CRC to the message. A scrambler 514 may receive a semi-persistent C-RNTI for a recipient UE, generate scrambling bits based on the semi-persistent C-RNTI, and scrambles the scheduling message and CRC with the scrambling bits. An encoder 516 may encode the scrambled scheduling message and provide an encoded message, which may be further processed and sent on the PDCCH.

FIG. 5 shows an exemplary design of a processing unit for generating and processing a scheduling message for semi-persistent scheduling. The scheduling message may also be generated and processed in other manners.

FIG. 6 shows a design of a process 600 for receiving data with semi-persistent scheduling. Process 600 may be performed by a UE (as described below) or by some other entity. The UE may receive a semi-persistent assignment that may be valid for multiple transmissions of data (block 612). The semi-persistent assignment may comprise a set of parameters for sending the multiple transmissions of data to the UE, e.g., all or some of the parameters shown in Table 1 and/or other parameters. The semi-persistent assignment may also comprise an assignment of ACK resource. The UE may obtain the assignment of ACK resource from the semi-persistent assignment (block 614). The ACK resource may be assigned to the UE for the multiple transmissions of data. The UE may receive a transmission of data sent in accordance with the semi-persistent assignment (block 616). The UE may process the received transmission and determine ACK information for the transmission of data (block 618). The transmission of data may be for one or more transport blocks, and the ACK information may indicate whether each transport block was decoded correctly or in error by the UE. The UE may send the ACK information with the ACK resource (block 620). The UE may receive additional transmissions of data sent in accordance with the

semi-persistent assignment. The UE may send ACK information for these additional transmissions of data with the ACK resource.

In one design of block **612**, the UE may receive a scheduling message carrying the semi-persistent assignment. In one design, the UE may detect for the scheduling message for semi-persistent scheduling based on a C-RNTI used for semi-persistent scheduling. In another design, the UE may determine that the scheduling message is for semi-persistent scheduling based on different scrambling, a special bit, etc. The scheduling message may also be used to send scheduling information for a single transmission of data with dynamic scheduling. For dynamic scheduling, the ACK resource may be determined based on the resources (e.g., a starting CCE) used to send the scheduling message.

In one design of block **614**, the UE may obtain an index of the ACK resource assigned to the UE from at least one field of the scheduling message. The UE may determine the ACK resource based on the index and a set of configured ACK resources (e.g., configured by RRC). The at least one field may include a new data indicator field, a redundancy version field, an MCS field, a TPC command field, other fields, or any combination thereof.

In one design, for LTE, the UE may receive the semi-persistent assignment on the PDCCH and may receive the transmission of data on the PDSCH. The ACK resource may be for the PUCCH. The UE may also receive the semi-persistent assignment and the transmission of data on other downlink channels and may send ACK information on other uplink channels.

FIG. 7 shows a design of an apparatus **700** for receiving data in a wireless communication system. Apparatus **700** includes a module **712** to receive a semi-persistent assignment valid for multiple transmissions of data for a UE, a module **714** to obtain an assignment of ACK resource from the semi-persistent assignment, with the ACK resource being assigned to the UE for the multiple transmissions of data, a module **716** to receive a transmission of data sent in accordance with the semi-persistent assignment, a module **718** to determine ACK information for the transmission of data, and a module **720** to send the ACK information with the ACK resource.

FIG. 8 shows a design of a process **800** for receiving data with dynamic scheduling and semi-persistent scheduling. Process **800** may be performed by a UE (as described below) or by some other entity. The UE may receive a first scheduling message carrying scheduling information for a single transmission of data with dynamic scheduling (block **812**). The UE may receive a first transmission of data sent in accordance with the scheduling information (block **814**). The UE may send first ACK information for the first transmission of data with first ACK resource associated with a resource (e.g., a CCE) used to send the first scheduling message (block **816**). The first ACK resource may be valid for a single transmission of ACK information.

The UE may also receive a second scheduling message carrying a semi-persistent assignment for multiple transmissions of data with semi-persistent scheduling (block **818**). The UE may receive a second transmission of data sent in accordance with the semi-persistent assignment (block **820**). The UE may send second ACK information for the second transmission of data with second ACK resource conveyed by the semi-persistent assignment (block **822**). The UE may receive additional transmissions of data sent in accordance with the semi-persistent assignment. The UE may send ACK information for these additional transmissions of data with

the second ACK resource, which may be valid for multiple transmissions of ACK information.

In one design, the UE may obtain an index of the second ACK resource from at least one field of the second scheduling message. The first and second scheduling messages may have the same format (e.g., as shown in FIG. 4A or 4B) or different formats (e.g., as shown in FIGS. 4A and 4B). These scheduling messages may include the at least one field and one or more additional fields. The at least one field may carry an ACK resource index for semi-persistent scheduling and may carry scheduling information for dynamic scheduling.

In one design, the UE may detect for the first scheduling message based on a first C-RNTI assigned to the UE. The UE may detect for the second scheduling message based on a second C-RNTI assigned to the UE for semi-persistent scheduling. The UE may also determine whether a scheduling message is for dynamic scheduling or semi-persistent scheduling based on other mechanisms, e.g., different scrambling, a special bit in the scheduling message, etc.

In one design, the UE may obtain a first MCS value from the first scheduling message and may process the first transmission of data in accordance with the first MCS value. The first MCS value may be one of a first plurality of MCS values applicable for dynamic scheduling. The UE may obtain a second MCS value from the second scheduling message and may process the second transmission of data in accordance with the second MCS value. The second MCS value may be one of a second plurality of MCS values applicable for semi-persistent scheduling. The second plurality of MCS values may be fewer than the first plurality of MCS values, and the second MCS value may be sent with fewer bits than the first MCS value.

FIG. 9 shows a design of an apparatus **900** for receiving data in a wireless communication system. Apparatus **900** includes a module **912** to receive a first scheduling message carrying scheduling information for a single transmission of data, a module **914** to receive a first transmission of data sent in accordance with the scheduling information, a module **916** to send first ACK information for the first transmission of data with first ACK resource associated with a resource used to send the first scheduling message, a module **918** to receive a second scheduling message carrying a semi-persistent assignment for multiple transmissions of data, a module **920** to receive a second transmission of data sent in accordance with the semi-persistent assignment, and a module **922** to send second ACK information for the second transmission of data with second ACK resource conveyed by the semi-persistent assignment.

FIG. 10 shows a design of a process **1000** for sending data with semi-persistent scheduling. Process **1000** may be performed by a Node B (as described below) or by some other entity. The Node B may assign ACK resource to a UE for semi-persistent scheduling (block **1012**). The Node B may send a semi-persistent assignment comprising the ACK resource to the UE (block **1014**). The semi-persistent assignment may be valid for multiple transmissions of data. The ACK resource may be assigned to the UE for the multiple transmissions of data. The Node B may send a transmission of data in accordance with the semi-persistent assignment to the UE (block **1016**). The Node B may receive ACK information for the transmission of data, with the ACK information being sent by the UE with the ACK resource (block **1018**). The Node B may send additional transmissions of data in accordance with the semi-persistent assignment. The Node B may receive ACK information for these additional transmissions of data on the ACK resource.

11

In one design of block **1014**, the Node B may map an index of the ACK resource assigned to the UE to at least one field of a scheduling message. The at least one field may include a new data indicator field, a redundancy version field, an MCS field, a TPC command field, and/or other fields. The Node B may map remaining information for the semi-persistent assignment to remaining fields and bits of the scheduling message. In one design, the Node B may process the scheduling message based on a C-RNTI used for semi-persistent scheduling. The Node B may also indicate that the scheduling message is for semi-persistent scheduling based on other mechanisms. The Node B may send the scheduling message to the UE. The scheduling message may also be used to send scheduling information for dynamic scheduling.

In one design, for LTE, the Node B may send the semi-persistent assignment on the PDCCH and may send the transmission of data on the PDSCH. The ACK resource may be for the PUCCH. The Node B may also send the semi-persistent assignment and the transmission of data on other downlink channels and may receive ACK information on other uplink channels.

FIG. **11** shows a design of an apparatus **1100** for sending data in a wireless communication system. Apparatus **1100** includes a module **1112** to assign ACK resource to a UE, a module **1114** to send a semi-persistent assignment comprising the ACK resource to the UE, the semi-persistent assignment being valid for multiple transmissions of data, the ACK resource being assigned to the UE for the multiple transmissions of data, a module **1116** to send a transmission of data in accordance with the semi-persistent assignment to the UE, and a module **1118** to receive ACK information for the transmission of data, the ACK information being sent by the UE with the ACK resource.

FIG. **12** shows a design of a process **1200** for sending data with dynamic scheduling and semi-persistent scheduling. Process **1200** may be performed by a Node B (as described below) or by some other entity. The Node B may send to a UE a first scheduling message carrying scheduling information for a single transmission of data (block **1212**). The Node B may send a first transmission of data in accordance with the scheduling information to the UE (block **1214**). The Node B may receive first ACK information for the first transmission of data, with the first ACK information being sent by the UE with first ACK resource associated with a resource (e.g., a CCE) used to send the first scheduling message (block **1216**). The first ACK resource may be valid for a single transmission of ACK information.

The Node B may send to the UE a second scheduling message carrying a semi-persistent assignment for multiple transmissions of data (block **1218**). The Node B may send a second transmission of data in accordance with the semi-persistent assignment to the UE (block **1220**). The Node B may receive second ACK information for the second transmission of data, with the second ACK information being sent by the UE with second ACK resource conveyed by the semi-persistent assignment (block **1222**). The Node B may send additional transmissions of data in accordance with the semi-persistent assignment. The Node B may receive ACK information for these additional transmissions of data on the second ACK resource, which may be valid for multiple transmissions of ACK information.

In one design of block **1218**, the Node B may map an index of the second ACK resource to at least one field of the second scheduling message. The first and second scheduling messages may have the same format or different formats and may include the at least one field and one or more additional

12

fields. The at least one field may carry an ACK resource index for semi-persistent scheduling and may carry scheduling information for dynamic scheduling.

In one design, the Node B may process (e.g., scramble a CRC for) the first scheduling message with a first C-RNTI assigned to the UE. The Node B may process the second scheduling message with a second C-RNTI assigned to the UE for semi-persistent scheduling. The Node B may also indicate whether a scheduling message is for dynamic scheduling or semi-persistent scheduling based on other mechanisms.

In one design, the Node B may select a first MCS value from a first plurality of MCS values applicable for dynamic scheduling. The Node B may process the first transmission of data in accordance with the first MCS value. The Node B may select a second MCS value from a second plurality of MCS values applicable for semi-persistent scheduling. The Node B may process the second transmission of data in accordance with the second MCS value. The second plurality of MCS values may be fewer than the first plurality of MCS values.

FIG. **13** shows a design of an apparatus **1300** for sending data in a wireless communication system. Apparatus **1300** includes a module **1312** to send to a UE a first scheduling message carrying scheduling information for a single transmission of data, a module **1314** to send a first transmission of data in accordance with the scheduling information to the UE, a module **1316** to receive first ACK information for the first transmission of data on first ACK resource associated with a resource used to send the first scheduling message, a module **1318** to send to the UE a second scheduling message carrying a semi-persistent assignment for multiple transmissions of data, a module **1320** to send a second transmission of data in accordance with the semi-persistent assignment to the UE, and a module **1322** to receive second ACK information for the second transmission of data on second ACK resource conveyed by the semi-persistent assignment.

The modules in FIGS. **7**, **9**, **11** and **13** may comprise processors, electronics devices, hardware devices, electronics components, logical circuits, memories, software codes, firmware codes, etc., or any combination thereof.

The techniques described herein may allow for efficient assignment of ACK resources for semi-persistent scheduling. For dynamic scheduling, ACK resources may be associated with CCEs carrying scheduling information and may be conveniently assigned to UEs without incurring additional signaling overhead. This is possible when each transmission of data on the PDSCH is scheduled with scheduling information sent on the PDCCH. For semi-persistent scheduling, a semi-persistent assignment may be sent once on the PDCCH with the first transmission of data, and no scheduling information may be sent for subsequent new transmissions of data. In this case, the ACK resources for the subsequent new transmissions of data cannot be associated with the CCEs carrying scheduling information and may be provided by the semi-persistent assignment, as described above.

The techniques described herein allow for dynamic assignment of ACK resources for semi-persistent scheduling using Layer 1 signaling sent on the PUCCH, as described above. The techniques may be more efficient (in terms of overhead) than assigning ACK resources for semi-persistent scheduling using Layer 3 (e.g., RRC) signaling. The techniques may also be more efficient (in terms of resource usage) than statically assigning each active UE with ACK resource for semi-persistent scheduling.

FIG. 14 shows a block diagram of a design of a Node B 110 and a UE 120, which may be one of the Node Bs and one of the UEs in FIG. 1. In this design, Node B 110 is equipped with T antennas 1434a through 1434t, and UE 120 is equipped with R antennas 1452a through 1452r, where in general $T \geq 1$ and $R \geq 1$.

At Node B 110, a transmit processor 1420 may receive data (e.g., transport blocks) for one or more UEs from a data source 1412, process the data for each UE based on one or more MCS values for that UE, and provide data symbols for all UEs. Transmit processor 1420 may also process control information (e.g., scheduling messages for dynamic scheduling and semi-persistent scheduling) from a controller/processor 1440 and provide control symbols. A transmit (TX) multiple-input multiple-output (MIMO) processor 1430 may multiplex the data symbols, the control symbols, and/or pilot symbols. TX MIMO processor 1430 may perform spatial processing (e.g., precoding) on the multiplexed symbols, if applicable, and provide T output symbol streams to T modulators (MODs) 1432a through 1432t. Each modulator 1432 may process a respective output symbol stream (e.g., for OFDM) to obtain an output sample stream. Each modulator 1432 may further process (e.g., convert to analog, amplify, filter, and upconvert) the output sample stream to obtain a downlink signal. T downlink signals from modulators 1432a through 1432t may be transmitted via T antennas 1434a through 1434t, respectively.

At UE 120, antennas 1452a through 1452r may receive the downlink signals from Node B 110 and provide received signals to demodulators (DEMODs) 1454a through 1454r, respectively. Each demodulator 1454 may condition (e.g., filter, amplify, downconvert, and digitize) a respective received signal to obtain input samples. Each demodulator 1454 may further process the input samples (e.g., for OFDM) to obtain received symbols. A MIMO detector 1456 may obtain received symbols from all R demodulators 1454a through 1454r, perform MIMO detection on the received symbols if applicable, and provide detected symbols. A receive processor 1458 may process (e.g., demodulate, deinterleave, and decode) the detected symbols, provide decoded data for UE 120 to a data sink 1460, and provide decoded control information to a controller/processor 1480.

On the uplink, at UE 120, data from a data source 1462 and control information (e.g., ACK information, etc.) from controller/processor 1480 may be processed by a transmit processor 1464, precoded by a TX MIMO processor 1466 if applicable, conditioned by modulators 1454a through 1454r, and transmitted to Node B 110. At Node B 110, the uplink signals from UE 120 may be received by antennas 1434, conditioned by demodulators 1432, processed by a MIMO detector 1436 if applicable, and further processed by a receive processor 1438 to obtain the data and control information transmitted by UE 120.

Controllers/processors 1440 and 1480 may direct the operation at Node B 110 and UE 120, respectively. Processor 1480 and/or other processors and modules at UE 120 may perform or direct process 600 in FIG. 6, process 800 in FIG. 8, and/or other processes for the techniques described herein. Processor 1440 and/or other processors and modules at Node B 110 may perform or direct process 1000 in FIG. 10, process 1200 in FIG. 12, and/or other processes for the techniques described herein. Transmit processor 1420 may implement processing unit 500 in FIG. 5. Memories 1442 and 1482 may store data and program codes for Node B 110 and UE 120, respectively. A scheduler 1444 may schedule

UEs for downlink and/or uplink transmission and may provide assignments of resources (e.g., ACK resources) for the scheduled UEs.

Those of skill in the art would understand that information and signals may be represented using any of a variety of different technologies and techniques. For example, data, instructions, commands, information, signals, bits, symbols, and chips that may be referenced throughout the above description may be represented by voltages, currents, electromagnetic waves, magnetic fields or particles, optical fields or particles, or any combination thereof.

Those of skill would further appreciate that the various illustrative logical blocks, modules, circuits, and algorithm steps described in connection with the disclosure herein may be implemented as electronic hardware, computer software, or combinations of both. To clearly illustrate this interchangeability of hardware and software, various illustrative components, blocks, modules, circuits, and steps have been described above generally in terms of their functionality. Whether such functionality is implemented as hardware or software depends upon the particular application and design constraints imposed on the overall system. Skilled artisans may implement the described functionality in varying ways for each particular application, but such implementation decisions should not be interpreted as causing a departure from the scope of the present disclosure.

The various illustrative logical blocks, modules, and circuits described in connection with the disclosure herein may be implemented or performed with a general-purpose processor, a digital signal processor (DSP), an application specific integrated circuit (ASIC), a field programmable gate array (FPGA) or other programmable logic device, discrete gate or transistor logic, discrete hardware components, or any combination thereof designed to perform the functions described herein. A general-purpose processor may be a microprocessor, but in the alternative, the processor may be any conventional processor, controller, microcontroller, or state machine. A processor may also be implemented as a combination of computing devices, e.g., a combination of a DSP and a microprocessor, a plurality of microprocessors, one or more microprocessors in conjunction with a DSP core, or any other such configuration.

The steps of a method or algorithm described in connection with the disclosure herein may be embodied directly in hardware, in a software module executed by a processor, or in a combination of the two. A software module may reside in RAM memory, flash memory, ROM memory, EPROM memory, EEPROM memory, registers, hard disk, a removable disk, a CD-ROM, or any other form of storage medium known in the art. An exemplary storage medium is coupled to the processor such that the processor can read information from, and write information to, the storage medium. In the alternative, the storage medium may be integral to the processor. The processor and the storage medium may reside in an ASIC. The ASIC may reside in a user terminal. In the alternative, the processor and the storage medium may reside as discrete components in a user terminal.

In one or more exemplary designs, the functions described may be implemented in hardware, software, firmware, or any combination thereof. If implemented in software, the functions may be stored on or transmitted over as one or more instructions or code on a computer-readable medium. Computer-readable media includes both computer storage media and communication media including any medium that facilitates transfer of a computer program from one place to another. A storage media may be any available media that can be accessed by a general purpose or special

15

purpose computer. By way of example, and not limitation, such computer-readable media can comprise RAM, ROM, EEPROM, CD-ROM or other optical disk storage, magnetic disk storage or other magnetic storage devices, or any other medium that can be used to carry or store desired program code means in the form of instructions or data structures and that can be accessed by a general-purpose or special-purpose computer, or a general-purpose or special-purpose processor. Also, any connection is properly termed a computer-readable medium. For example, if the software is transmitted from a website, server, or other remote source using a coaxial cable, fiber optic cable, twisted pair, digital subscriber line (DSL), or wireless technologies such as infrared, radio, and microwave, then the coaxial cable, fiber optic cable, twisted pair, DSL, or wireless technologies such as infrared, radio, and microwave are included in the definition of medium. Disk and disc, as used herein, includes compact disc (CD), laser disc, optical disc, digital versatile disc (DVD), floppy disk and blu-ray disc where disks usually reproduce data magnetically, while discs reproduce data optically with lasers. Combinations of the above should also be included within the scope of computer-readable media.

The previous description of the disclosure is provided to enable any person skilled in the art to make or use the disclosure. Various modifications to the disclosure will be readily apparent to those skilled in the art, and the generic principles defined herein may be applied to other variations without departing from the spirit or scope of the disclosure. Thus, the disclosure is not intended to be limited to the examples and designs described herein but is to be accorded the widest scope consistent with the principles and novel features disclosed herein.

What is claimed is:

1. A method for wireless communication at a user equipment (UE), comprising:
 - receiving a scheduling message according to a message format that is associated with both semi-persistent assignments that are valid for multiple transmissions of data and dynamic assignments that are valid for single transmissions of data, wherein the message format comprises a new data indicator field that, for the dynamic assignments, carries information used in processing transmissions associated with the dynamic assignments, and for the semi-persistent assignments, is set to a designated value for validation of the semi-persistent assignments;
 - validating that the received scheduling message comprises a semi-persistent assignment based at least in part on a comparison of the new data indicator field to the designated value;
 - obtaining an assignment of a first acknowledgement (ACK) resource from a transmit power control (TPC) field of the scheduling message for the semi-persistent assignment;
 - receiving the multiple transmissions of data sent in accordance with the semi-persistent assignment;
 - determining first ACK information for a first transmission of data of the multiple transmissions of data; and sending the first ACK information on the first ACK resource.
2. The method of claim 1, wherein the message format further comprises one or more of: a hybrid automatic repeat request (HARQ) field, a redundancy version field, a resource block assignment field, or a modulation and coding scheme (MCS) field.

16

3. The method of claim 1, further comprising: detecting the scheduling message based on a semi-persistent scheduling cell radio network temporary identifier assigned to the UE that is different from a cell radio network temporary identifier assigned to the UE for detection of the dynamic assignments.
4. The method of claim 1, further comprising: receiving a dynamic assignment for a retransmission of the first transmission of data in a second scheduling message in response to indicating that the first transmission of data was decoded in error in the first ACK information; and receiving the retransmission of the first transmission of data according to the dynamic assignment.
5. The method of claim 4, further comprising: obtaining a second assignment of a second ACK resource based on a resource used to send the second scheduling message; and determining second ACK information for the retransmission of the first transmission of data; and sending the second ACK information on the second ACK resource.
6. The method of claim 1, wherein the scheduling message comprising the semi-persistent assignment is received on a physical downlink control channel (PDCCH) and the multiple transmissions of data are received on a physical downlink shared channel (PDSCH).
7. The method of claim 1, further comprising: receiving a semi-persistent scheduling interval for the multiple transmissions of data via upper layer signaling.
8. The method of claim 1, wherein the designated value comprises all zeros.
9. The method of claim 2, wherein one or more of the HARQ field, the redundancy version field, the resource block assignment field, the MCS field, or the TPC command field are set to designated values for the validation of the semi-persistent assignments.
10. A method for wireless communication, comprising: mapping, according to a message format that is associated with both semi-persistent assignments that are valid for multiple transmissions of data and dynamic assignments that are valid for single transmissions of data, scheduling information for a semi-persistent assignment to a scheduling message intended for a user equipment (UE), wherein the message format comprises a new data indicator field that, for the dynamic assignments, carries information used in processing transmissions associated with the dynamic assignments, and for the semi-persistent assignments, is set to a designated value for validation of the semi-persistent assignments;
- mapping the new data indicator field to a designated value, wherein the designated value indicates that the scheduling message comprises a semi-persistent assignment;
- mapping an assignment of a first acknowledgement (ACK) resource to a transmit power control (TPC) command field of the scheduling message for the semi-persistent assignment;
- sending the scheduling message to the UE;
- sending the multiple transmissions of data to the UE according to the semi-persistent assignment; and receiving first ACK information on the first ACK resource.
11. The method of claim 10, wherein the message format further comprises one or more of: a hybrid automatic repeat

17

request (HARQ) field, a redundancy version field, a resource block assignment field, or a modulation and coding scheme (MCS) field.

12. The method of claim 10, further comprising:

scrambling the scheduling message using a semi-persistent scheduling cell radio network temporary identifier assigned to the UE that is different from a cell radio network temporary identifier assigned to the UE for detection of the dynamic assignments.

13. The method of claim 12, wherein the scrambling the scheduling message using the semi-persistent scheduling cell radio network temporary identifier assigned to the UE comprises scrambling a cyclic redundancy check (CRC) associated with the scheduling message with the semi-persistent scheduling cell radio network temporary identifier assigned to the UE.

14. The method of claim 12, wherein the

first ACK information indicates that a first transmission of data of the multiple transmissions of data was decoded in error, the method further comprising:

sending a dynamic assignment for a retransmission of the first transmission of data in a second scheduling message to the UE; and

sending the retransmission to the UE according to the dynamic assignment.

15. The method of claim 14, further comprising:

receiving second ACK information associated with the retransmission on a second ACK resource determined based on a resource used to send the second scheduling message.

16. The method of claim 10, wherein the scheduling message comprising the semi-persistent assignment is sent on a physical downlink control channel (PDCCH) and the multiple transmissions of data are sent on a physical downlink shared channel (PDSCH).

17. The method of claim 10, further comprising:

sending a semi-persistent scheduling interval for the multiple transmissions of data to the UE via upper layer signaling.

18. The method of claim 10, wherein the designated value comprises all zeros.

19. The method of claim 11, wherein one or more of the HARQ field, the redundancy version field, the resource block assignment field, the MCS field, or the TPC command field are set to designated values for the validation of the semi-persistent assignments.

20. An apparatus for wireless communication at a user equipment (UE), comprising:

at least one processor;

a memory coupled to the at least one processor, the memory comprising instructions that, when executed by the at least one processor, cause the at least one processor to:

receive a scheduling message according to a message format that is associated with both semi-persistent assignments that are valid for multiple transmissions of data and dynamic assignments that are valid for single transmissions of data, wherein the message format comprises a new data indicator field that,

for the dynamic assignments, carries information used in processing transmission associated with the dynamic assignments, and

for the semi-persistent assignments, is set to a designated value for validation of the semi-persistent assignments;

18

validate that the received scheduling message comprises a semi-persistent assignment based at least in part on a comparison of the new data indicator field to the designated value;

obtain an assignment of a first acknowledgement (ACK) resource from a transmit power control (TPC) command field of the scheduling message for the semi-persistent assignment;

determine first ACK information for a first transmission of data of the multiple transmissions of data;

receive the multiple transmissions of data sent in accordance with the semi-persistent assignment; and

send the first ACK information on the first ACK resource.

21. The apparatus of claim 20, wherein the message format further comprises one or more of: a hybrid automatic repeat request (HARQ) field, a redundancy version field, a resource block assignment field, or a modulation and coding scheme (MCS) field.

22. The apparatus of claim 20, wherein the at least one processor is further configured to:

detect the scheduling message based on a semi-persistent scheduling cell radio network temporary identifier assigned to the UE that is different from a cell radio network temporary identifier assigned to the UE for detection of the dynamic assignments.

23. The apparatus of claim 20, wherein the at least one processor is further configured to:

receive a dynamic assignment for a retransmission of the first transmission of data in a second scheduling message in response to indicating that the first transmission of data was decoded in error in the first ACK information; and

receive the retransmission of the first transmission of data according to the dynamic assignment.

24. The apparatus of claim 23, wherein the at least one processor is further configured to:

obtain a second assignment of a second ACK resource based on a resource used to send the second scheduling message; and

determine second ACK information for the retransmission of the first transmission of data; and

send the second ACK information on the second ACK resource.

25. The apparatus of claim 21, wherein one or more of the HARQ field, the redundancy version field, the resource block assignment field, the MCS field, or the TPC command field are set to designated values for the validation of the semi-persistent assignments.

26. An apparatus for wireless communication, comprising:

at least one processor;

a memory coupled to the at least one processor, the memory comprising instructions that, when executed by the at least one processor, cause the at least one processor to:

map, according to a message format that is associated with both semi-persistent assignments that are valid for multiple transmissions of data and dynamic assignments that are valid for single transmissions of data, scheduling information for a semi-persistent assignment to a scheduling message intended for a user equipment (UE), wherein the message format comprises a new data indicator field that,

for the dynamic assignments, carries information used in processing transmissions associated with the dynamic assignments, and

19

for the semi-persistent assignments, is set to a designated value for validation of the semi-persistent assignments;

map the new data indicator field to a designated value, wherein the designated value indicates that the scheduling message comprises a semi-persistent assignment; 5

map an assignment of a first acknowledgement (ACK) resource using a transmit power control (TPC) command field of the scheduling message for the semi-persistent assignment; 10

send the scheduling message to the UE; and

send the multiple transmissions of data to the UE according to the semi-persistent assignment; and

receive first ACK information on the first ACK resource.

27. The apparatus of claim 26, wherein the message format further comprises one or more of: a hybrid automatic repeat request (HARQ) field, a redundancy version field, a resource block assignment field, or a modulation and coding scheme (MCS) field. 15

28. The apparatus of claim 26, wherein the at least one processor is further configured to: 20

scramble the scheduling message using a semi-persistent scheduling cell radio network temporary identifier assigned to the UE that is different from a cell radio network temporary identifier assigned to the UE for detection of the dynamic assignments. 25

29. The apparatus of claim 26, wherein the at least one processor is further configured to scramble a cyclic redundancy check (CRC) associated with the scheduling message with a semi-persistent scheduling cell radio network temporary identifier assigned to the UE for semi-persistent scheduling. 30

30. The apparatus of claim 26, wherein the first ACK information indicates that a first transmission of data of the multiple transmissions of data was decoded in error, and wherein the processor is further configured to: 35

send a dynamic assignment for a retransmission of the first transmission of data in a second scheduling message to the UE; and 40

send the retransmission to the UE according to the dynamic assignment.

31. The apparatus of claim 30, wherein the at least one processor is further configured to: 45

receive second ACK information associated with the retransmission on a second ACK resource determined based on a resource used to send the second scheduling message.

32. The apparatus of claim 27, wherein one or more of the HARQ field, the redundancy version field, the resource block assignment field, the MCS field, or the TPC command field are set to designated values for the validation of the semi-persistent assignments. 50

33. A non-transitory computer-readable medium for wireless communication at a user equipment (UE), comprising code that, when executed by at least one computer, causes the at least one computer to: 55

20

receive a scheduling message according to a message format that is associated with both semi-persistent assignments that are valid for multiple transmissions of data and dynamic assignments that are valid for single transmissions of data, wherein the message format comprises a new data indicator field that, 5

for the dynamic assignments, carries information used in processing transmissions associated with the dynamic assignments, and

for the semi-persistent assignments, is set to a designated value for validation of the semi-persistent assignments; 10

validate that the received scheduling message comprises a semi-persistent assignment based at least in part on a comparison of the new data indicator field to the designated value;

obtain an assignment of a first acknowledgement (ACK) resource from a transmit power control (TPC) command field of the scheduling message for the semi-persistent assignment; 15

receive the multiple transmissions of data sent in accordance with the semi-persistent assignment;

determine first ACK information for a first transmission of data of the multiple transmissions of data; and

send the first ACK information on the first ACK resource. 20

34. A non-transitory computer-readable medium for wireless communication comprising code that, when executed by at least one computer, causes the at least one computer to: 25

map, according to a message format that is associated with both semi-persistent assignments that are valid for multiple transmissions of data and dynamic assignments that are valid for single transmissions of data, scheduling information for a semi-persistent assignment to a scheduling message intended for a user equipment (UE), wherein the message format comprises a new data indicator field that, 30

for the dynamic assignments, carries information used in processing transmissions associated with the dynamic assignments, and

for the semi-persistent assignments, is set to a designated value for validation of the semi-persistent assignments; 35

map the new data indicator field to a designated value, wherein the designated value indicates that the scheduling message comprises a semi-persistent assignment; 40

map an assignment of a first acknowledgement (ACK) resource using a transmit power control (TPC) command field of the scheduling message for the semi-persistent assignment; 45

send the scheduling message to the UE;

send the multiple transmissions of data to the UE according to the semi-persistent assignment; and 50

receive first ACK information on the first ACK resource. 55

* * * * *