



(51) International Patent Classification:

<i>B42D 13/00</i> (2006.01)	<i>B42D 25/382</i> (2014.01)
<i>B42D 25/23</i> (2014.01)	<i>B42D 25/387</i> (2014.01)
<i>B42D 25/24</i> (2014.01)	<i>B42D 25/41</i> (2014.01)
<i>B42D 25/309</i> (2014.01)	<i>B42D 25/455</i> (2014.01)
<i>B42D 25/351</i> (2014.01)	<i>B42D 25/46</i> (2014.01)

(21) International Application Number:

PCT/IB2024/000297

(22) International Filing Date:

11 June 2024 (11.06.2024)

(25) Filing Language:

English

(26) Publication Language:

English

(30) Priority Data:

23305932.8 12 June 2023 (12.06.2023) EP

(71) Applicant: **LINXENS HOLDING** [FR/FR]; 37 rue des
Closeaux, 78200 Mantes la Jolie (FR).

(72) Inventors: **KHUSUWAN, Khiengkrai**; 142 Moo 1, Hi-
Tech Industrial Estate, Tambon Ban Laean, Amphor

Bang-pa-in, Phra Nakhon Si Ayutthaya, 13160 (TH).
SOMKHANTEE, Niwat; 142 Moo 1, Hi-Tech Industrial
Estate Tambon Ban Laean, Amphor Bang-pa-in, Phra
Nakhon Si Ayutthaya, 13160 (TH). **GOURMELEN, Vin-
cent**; 142 Moo 1, Hi-Tech Industrial Estate Tambon Ban
Laeon, Amphor Bang-pa-in, Phra Nakhon Si Ayutthaya,
13160 (TH). **SUPATHAM, Patcharapol**; 142 Moo 1, Hi-
Tech Industrial Estate Tambon Ban Laean, Amphor Bang-
pa-in, Phra Nakhon Si Ayutthaya, 13160 (TH).

(74) Agent: **NEUBECK, Wolfgang**; 260 Boulevard Saint-Ger-
main, 75007 paris (FR).

(81) Designated States (unless otherwise indicated, for every
kind of national protection available): AE, AG, AL, AM,
AO, AT, AU, AZ, BA, BB, BG, BH, BN, BR, BW, BY, BZ,
CA, CH, CL, CN, CO, CR, CU, CV, CZ, DE, DJ, DK, DM,
DO, DZ, EC, EE, EG, ES, FI, GB, GD, GE, GH, GM, GT,
HN, HR, HU, ID, IL, IN, IQ, IR, IS, IT, JM, JO, JP, KE, KG,
KH, KN, KP, KR, KW, KZ, LA, LC, LK, LR, LS, LU, LY,
MA, MD, MG, MK, MN, MU, MW, MX, MY, MZ, NA,
NG, NI, NO, NZ, OM, PA, PE, PG, PH, PL, PT, QA, RO,
RS, RU, RW, SA, SC, SD, SE, SG, SK, SL, ST, SV, SY, TH,

(54) Title: STRUCTURE FOR A SECURITY DOCUMENT WITH PHOTOCROMIC FEATURES AND METHOD OF FORMING
SAME

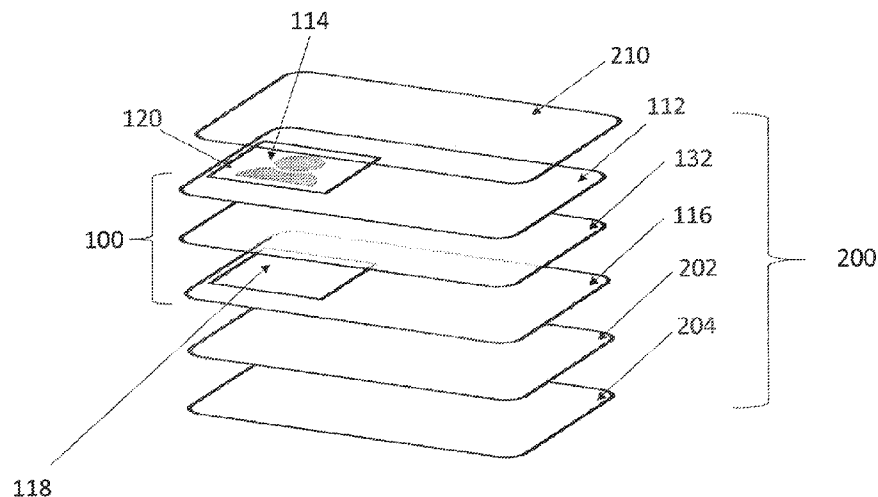

Fig. 1

(57) Abstract: The present invention refers to a structure for a security document, which comprises a first layer comprising a user identification area for forming an image of a user, and a second layer including a photochromic ink area comprising photochromic ink, wherein the photochromic ink area is placed in correspondence with the user identification area. The present invention further refers to a security document comprising the laminated structure obtained from the disclosed structure.



TJ, TM, TN, TR, TT, TZ, UA, UG, US, UZ, VC, VN, WS,
ZA, ZM, ZW.

- (84) Designated States** (*unless otherwise indicated, for every kind of regional protection available*): ARIPO (BW, CV, GH, GM, KE, LR, LS, MW, MZ, NA, RW, SC, SD, SL, ST, SZ, TZ, UG, ZM, ZW), Eurasian (AM, AZ, BY, KG, KZ, RU, TJ, TM), European (AL, AT, BE, BG, CH, CY, CZ, DE, DK, EE, ES, FI, FR, GB, GR, HR, HU, IE, IS, IT, LT, LU, LV, MC, ME, MK, MT, NL, NO, PL, PT, RO, RS, SE, SI, SK, SM, TR), OAPI (BF, BJ, CF, CG, CI, CM, GA, GN, GQ, GW, KM, ML, MR, NE, SN, TD, TG).

Published:

- *with international search report (Art. 21(3))*
- *before the expiration of the time limit for amending the claims and to be republished in the event of receipt of amendments (Rule 48.2(h))*

STRUCTURE FOR A SECURITY DOCUMENT WITH PHOTOCHROMIC FEATURES AND METHOD OF FORMING SAME

Technical Field

The present invention relates to structures and laminated structures for security documents and to the corresponding security documents.

Background Art

Due to recent developments in society and industry, data processing and data handling require compliance with increasingly restrictive regulations so as to reduce the possibility of tampering with sensitive data. In many applications, sensitive data or information has to be stored in a permanent and tamper resistant manner, in particular, when data or information in non-electronic form, possibly in combination with electronically stored data, has to be stored in certain carriers. For example, credit cards, respective cards for health insurance, passports and the like, represent respective "carriers" having stored therein a significant amount of non-electronic information, for instance, in the form of one or more images, symbols, text and the like. Typically, this information, possibly in combination with electronically stored data, such as RFID labels and the like, is provided on the basis of a respective carrier, hereinafter referred to as "security document," which may have to provide for resistance of the stored information with respect to environmental influences, while, nevertheless, allowing frequent and long term use of a respective security document. For example, a passport may have to be typically used for a time period of several years and may, thus, depending on the habits of the passport owner, require a more or less frequent opening and closing, storing in sometimes harsh environments and the like. Similarly, any type of cards to be used in financial transactions and the like, may have to withstand mechanical stress upon interaction with respective card readers and the like, while also providing for high robustness and reliability during a daily use of any such security documents.

Moreover, in addition to mechanical robustness, the information included in a corresponding security document, such as a datapage of a passport and the like, has to provide for high tamper resistance so as to make difficult any intentional manipulation of the information stored in the respective datapage of the security document, while, preferably, upon attempting to manipulate the datapage, any such attempt should become recognizable in a visible or any other appropriate manner.

In view of the requirements for security documents disclosed above, it is an object of the present invention to further improve the tampering resistance of security documents.

Summary of the invention

According to a first aspect of the present invention, a structure for a security document is provided, which comprises:

a first layer comprising a user identification area for forming an image of a user, and

a second layer including a photochromic ink area comprising photochromic ink,

wherein the photochromic ink area is aligned in correspondence with the user identification area.

This structure is advantageous because it is provided with an additional security feature. In fact, any attempt of counterfeiting or tampering the structure according to the present invention would result in a damage of the second layer including the photochromic ink and would hence hinder the response of the structure to light illumination and light activation.

According to another aspect of the present invention, a laminated structure for a security document is provided, which comprises:

a first layer comprising a user identification area for forming an image of a user, and

a second layer including a photochromic ink area comprising photochromic ink

wherein the photochromic ink area is aligned in correspondence with the user identification area, and wherein the first and second layer are laminated together.

This configuration is advantageous because it provides the laminated structure with an additional security feature. In fact, any attempt of counterfeiting or tampering the laminated structure according to the present invention would result in a damage of the second layer including the photochromic ink and would hence hinder the response of the laminated structure to light illumination and light activation.

In the present disclosure, it is to be understood that a laminated structure for a security document refers to a stacked structure of individual plastic sheets, such as polycarbonate layers or sheets, which are stacked and cut into desired dimensions, thereby providing the possibility of inserting respective sensitive data carriers, such as an image and the like, and/or using one of the layers itself as a carrier of sensitive information. After having introduced at least a part of the sensitive data into the stacked structure, the individual plastic sheets of the stacked structure are heat treated so as to be laminated together and form the laminated structure. After lamination of additional security layers to the laminated structure, the security document is formed. The security document is a more or less continuous piece of material or monoblock, which cannot be separated

in a later stage without inducing significant damage and, thus, leaving behind recognizable traces of any sort of tampering attempt.

In the present disclosure, it is to be understood that the expression “the photochromic ink area is aligned in correspondence with the user identification area” refers to an alignment of the two areas along the stacking direction. In particular, this expression indicates that a projection of at least a plurality of the points of a cross-section of the photochromic ink area (i.e. some or all the points of the cross-section of the photochromic ink area) is comprised, or falls within, a cross-section of the user identification area. Accordingly, several configurations may be possible, wherein the photochromic ink area and the user identification area are considered aligned according to the definition of the present disclosure. For instance, a symmetric configuration may be possible, wherein a cross-section of the photochromic ink area is equal to a cross-section of the user identification area, so that all the points of the cross-section of the photochromic ink area can be projected onto the cross-section of the user identification area. For example, an asymmetric configuration may be possible, wherein the cross-section of the photochromic ink area differs from the cross-section of the user identification area, e.g. the cross-section of the photochromic ink area is larger or smaller than the cross-section of the user identification area, so that part of the points of the cross-section of the photochromic ink area can be projected onto the cross-section of the user identification area.

In the present disclosure, it is to be understood that the photochromic ink area is placed in correspondence with the user identification area so that they are formed in corresponding portions of the first and second layers, once the two layers are assembled to form the laminated structure.

The image of a user may be formed in the user identification area by means of any suitable technique, such as laser engraving or particle deposition. Preferably, the image of the user may be formed in black and white.

According to a preferred embodiment of the present invention, the user identification area and the photochromic ink area may have the same dimensions and they may be placed in correspondence to each other so as to be aligned, i.e. so that the edges of the user identification areas are aligned with the edges of the photochromic ink area.

According to another preferred embodiment of the present invention, the user identification area and the photochromic ink area may have different dimensions and the photochromic ink area may be larger than the user identification area. In this embodiment, it is to be understood that the photochromic ink area is placed in correspondence with the user identification area so that the projection of the user identification area on the second layer is included in the photochromic ink area.

According to another preferred embodiment of the present invention, the dimensions of the user identification area and the photochromic ink area may be different to each other and the user identification area may be larger than the photochromic ink area. In this embodiment, it is to be understood that the photochromic ink area is placed in correspondence with the user identification area so that the projection of the user identification area on the second layer includes the photochromic ink area.

According to other preferred embodiments of the present invention, the laminated structure may comprise additional layers directly laminated to the first layer and/or to the second layer, such as one or more overlay layers, and/or one or more intermediate layers placed between the first and the second layers.

According to a preferred embodiment of the present invention, the photochromic ink may be an ultraviolet (UV) photochromic ink that responds to UV illumination.

According to another aspect of the present invention, a security document is provided, which comprises a laminated structure as the ones described above and an image of a user formed in the user identification area.

The advantage of this configuration is that the security document is provided with an additional security feature. In fact, if the security document comprising the second layer with the photochromic ink is illuminated with a light source, then the photochromic ink is activated and a response, such as a change in color, is induced in the photochromic ink. As a consequence, the image formed in the user identification area, which is aligned with the photochromic ink area, can appear to change color after exposure to the light. This additional security feature can appear only when the security document is exposed to a suitable light source. For instance, if the photochromic ink is a UV photochromic ink, this additional security feature may appear only after UV irradiation. For instance, if the photochromic ink is an infrared (IR) photochromic ink, this additional security feature may appear only after UV irradiation.

According to another aspect of the present invention, a method for forming a structure for a security document is provided, the method comprising the following steps:

- Providing a first layer comprising a user identification area for forming an image of a user;
- Providing a second layer including a photochromic ink area comprising photochromic ink;
- Aligning the first layer and the second layer so that the photochromic ink area is placed in correspondence with the user identification area.

This method enables producing a laminated structure for a security document with the advantages disclosed above.

According to a preferred embodiment of the present invention, a method is provided, which further comprises the following step:

- Laminating the first layer and the second layer together so as to form a laminated structure.

According to a preferred embodiment of the present invention, a method is provided, which further comprises the following steps:

- Providing one or more intermediate layers between the first layer and the second layer;
- Laminating the first layer, the second layer and the one or more intermediate layers together so as to form a stacked laminated structure.

According to another aspect of the present invention, a method for operating a security document comprising a photochromic ink feature is provided, wherein the method comprises the following steps:

- Illuminating the security document with a light source, for instance a UV source; and
- Inducing a temporary color change in at least one part of the image, preferably in the background of the image.

The advantage of this method is that it enables checking that the security document has not been tampered nor counterfeited. In fact, any attempt to counterfeit or tamper the security document would result in a damage of the photochromic ink and in a hindrance of the response to light illumination. If, after exposure to a suitable light source, for instance a UV source, no change in the color of the image of the security document is observed, this may be an indication that the security document has been counterfeited. On the other hand, if, after exposure to a suitable light source, the image of the security document undergoes a temporary color change, for instance a temporary color change in the background of the image, this may be an indication that the security document is original and reliable.

It is to be understood that the temporary color change is induced in the part of the image which is aligned with the photochromic ink and which receives the light transmitted by the photochromic ink after light irradiation.

Brief description of the drawings

The present invention will be explained in detail with regard to the accompanying drawings in which:

Figure 1 schematically illustrates an exploded view of a security document according to an embodiment of the present invention;

Figure 2 schematically illustrates an exploded view of a security document according to another embodiment of the present invention;

Figure 3 schematically illustrates a cross sectional view of a security document according to an embodiment of a present invention;

Figure 4 schematically illustrates a cross sectional view of a security document according to another embodiment of the present invention;

Figure 5 schematically illustrates a cross sectional view of a security document according to another embodiment of the present invention;

Figure 6A schematically illustrates a security document according to the present invention, during a first step of use;

Figure 6B schematically illustrates a security document according to the present invention, during a further step of use;

Figure 6C schematically illustrates a security document according to the present invention, during a further step of use;

Figure 6D schematically illustrates a security document according to the present invention during a further step of use.

Detailed description

In the following, the present invention is described with reference to particular embodiments, as is illustrated in the enclosed figures. However, the present invention is not limited to the particular embodiments described in the following detailed description and shown in figures. Instead, the described embodiments simply exemplify the different features of the present invention, the scope of which is defined in the claims. Further modifications and variations of the present invention will be clear to the skilled person.

Fig. 1 schematically illustrates an exploded view of a security document 200 according to an embodiment of the present invention.

The security document 200 comprises a laminated structure 100 and additional layers 202 and 204, which are laminated to the laminated structure 100. The additional layers 202 and 204 may be white or transparent and they may include printed security features, such as images.

The laminated structure 100 comprises a first layer 112 comprising a user identification area 114 for forming an image 120 of a user, and a second layer 116 including a photochromic ink area 118 comprising photochromic ink, that is ink responding to light stimulation.

In the illustrative embodiment of Fig. 1, the laminated structure 100 further comprises an intermediate layer 132 placed between the first layer 112 and the second layer 116.

The first layer 112 and the second layer 116 are placed so that the user identification area 114 is placed in correspondence with the photochromic ink area 118. In the illustrative configuration of Fig. 1, the photochromic ink area 118 is larger than the user identification area 114 and the fact that the user identification area 114 is placed in correspondence with the photochromic ink area 118 indicates that they are positioned so that a projection of the user identification area 114 on the second layer 116 falls within the area of the photochromic ink area 118.

In the security document 200, the image 120 of the user is generated in the user identification area 114, for instance is generated by means of laser illumination. It is to be understood that the laminated structure 100 does not comprise the image 120 of the user, which is generated at a later stage of the manufacturing of the security document 200, for instance by the competent authorities.

The security document 200 further comprises an overlay layer 210 for protecting the image 120 of the user. The overlay layer 210 is laminated to the laminated structure 100.

Fig. 2 schematically illustrates an exploded view of a security document 200, according to another embodiment of the present invention.

The security document 200 comprises the laminated structure 100, the overlay layer 210, and the additional layers 202 and 204.

The laminated structure 100 that is schematically shown in Fig. 2 comprises a first layer 112 and a second layer 116 having the same features of the first and second layers 112 and 116 described with reference to Fig. 1. In the illustrative embodiment of Fig. 2, the first layer 112 and the second layer 116 are directly attached to each other so that the photochromic ink area 118 is directly in contact with the user identification area 114. In other words, in the embodiment shown in Fig. 2, there are no intermediate layers between the first layer 112 and the second layer 116.

Fig. 3 schematically illustrates a cross sectional view of a security document 200 according to an embodiment of the present invention.

The security document 200 comprises the laminated structure 100 and the additional layers 202 and 204.

In the laminated structure 100 of Fig. 3, the first layer 112 and the second layer 116 are indirectly attached to each other via the intermediate layers 132 and 134. In the laminated structure 100 of Fig. 3, two intermediate layers 132 and 134 are placed between the first layer 112 and the second layer 116. However, it is to be understood that any number of intermediate layers may be placed between the first layer 112 and the second layer 116, for instance one, three, four or more.

The intermediate layers 132 and 134 may be advantageously added to the laminated structure 100 to facilitate the process of image formation on the first layer 112. For instance, they may simplify the process of image formation by means of laser irradiation.

Preferably, the one or more intermediate layers 132 and 134 are transparent, so as to not hinder the effect of the photochromic ink on the image 120 placed on the user identification area 114.

The first layer 112 and the second layer 116 are advantageously positioned so that the user identification area 114 is in correspondence with the photochromic ink area 118. As can be seen in Fig. 3, the photochromic ink area 118 is larger than the user identification area 114: the user identification area 114 is placed in correspondence with the photochromic ink area 118, so that the projection of the user identification area 114 on the second layer 116 is included within the photochromic ink area 118. In this way, when the photochromic ink of the photochromic ink area 118 is activated by means of light irradiation (as will be described in detail below), the color change of the photochromic ink can be visible on the whole image 120 placed in the user identification area 114.

In the illustrative embodiment of Fig. 3, the photochromic ink is placed on the side of the second layer 116 facing towards the intermediate layer 134.

Fig. 4 schematically illustrates a cross sectional view of the security document 200 of Fig. 1.

The security document 200 comprises the laminated structure 100 and the additional layers 202 and 204. The size of the photochromic ink area 118 is larger than the size of the user identification area 114.

A single intermediate layer 132 is placed between the first layer 112 and the second layer 116.

In the illustrative configuration of Fig. 4, the photochromic ink is placed on the side of the second layer 116 in contact with intermediate layer 132.

Fig. 5 schematically illustrates a cross sectional view of the security document 200 of Fig. 2.

The security document 200 of Fig. 5 comprises the laminated structure 100 and the additional layers 202 and 204. The size of the photochromic ink area 118 is larger than the size of the user identification area 114.

As can be seen in Fig. 5, the first layer 112 and the second layer 116 are directly attached to each other so that the photochromic ink is in contact with the first layer 112.

The method for operating the security document 200 according to the present invention is described in detail with reference to Figs. 6A to 6D.

Fig. 6A schematically illustrates the security document 200, comprising the user's image 120, during a first step of use, when the security document 200 is not illuminated by any light source suitable for activating the photochromic ink. In the step shown in Fig. 6A, the photochromic ink is not activated and the image 120 has one or more predefined colors. For example, the profile of the user 122 may have a first predefined color and the background of the image 124 may have a second predefined color. Preferably, the second predefined color is white.

Fig. 6B schematically illustrates the security document 200 during a further step of use, when the security document 200 is illuminated with a light source suitable for activating the photochromic ink. For instance, if the photochromic ink is a UV photochromic ink, the suitable light source may be a UV source. For instance, if the photochromic ink is an IR photochromic ink, the suitable light source may be an IR source.

The security document 200 may be exposed to the light source for a time interval necessary for activating the photochromic ink, for instance a time interval comprised within 1 to 10 seconds, preferably a time interval comprised within 1 to 2 seconds.

As a consequence of the light irradiation, the photochromic ink is activated and changes its color. The effect of the color change in the photochromic ink may be visible also in the area of the image 120 which receives the light transmitted by the photochromic ink. Accordingly, the image 120 may appear to change one or more colors. For example, the profile of the user 122 may show a first modified color and/or the background of the image 124 may show a second modified color.

According to preferred embodiments, the color change may be visible on the background of the image 124 and the second modified color may be a color in the shades of yellow, and/or in the shades of green.

According to other preferred embodiments, the color change may be visible on the background of the image 124 and the background may appear brighter.

Fig. 6C schematically illustrates the security document 200 during a further step of use, within a predefined time interval after illumination with a suitable light source. After activation by means of light irradiation, the photochromic ink remains activated for a predefined time interval. Accordingly, within this predefined time interval, the color change is still visible in the photochromic ink and in the image 120. For instance, the effect of the activation of the photochromic ink may still be visible after a predefined time interval comprised between 1 minute and 10 seconds after light irradiation, preferably between 30 seconds and 15 seconds, depending on the condition and on the illumination of the environment where the security document 200 is placed.

Fig. 6D schematically illustrates the security document 200 in a final step of use. In Fig. 6D, the image 120 has returned to the original configuration of Fig. 6A. Accordingly, the color of the image 120 in Fig. 6D is the same as the color of the image 120 in Fig. 6A before light illumination. For example, the profile of the user 122 may have again the first predefined color and the background of the image 124 may have again the second predefined color.

It is hence to be understood that the color change induced by the photochromic ink on the image 120 is temporary and it lasts for a predefined time interval after the light illumination, for instance the predefined time interval may be comprised between 1 min and 10 sec, preferably between 30 sec and 15 sec, depending on the illumination condition of the environment.

The method described with reference to Figs. 6A to 6D may be advantageously used to check whether the security document 200 has been tampered with or damaged. In fact, any attempt to tamper with the security document 200 would damage the photochromic ink placed on the photochromic ink area 116 and would hinder the color change effect on the image 120 described above. Moreover, the photochromic ink provides an additional security feature to the security document 200, in that the photochromic ink feature is visible on the image 120 of the security document 200 only after exposure to a suitable light source.

Even if the present invention has been described with reference to the embodiments described above, it is clear to the skilled person that it is possible to apply different modifications, variations and improvements of the present invention in light of the teachings described above and the field,

and within the scope of the enclosed claims, without departing from the scope and purpose of the present invention.

For example, it is clear that, even if, in the embodiments shown in Figs. 1 to 5, the dimensions of the photochromic ink area 118 are larger than the dimensions of the user identification area 114, the photochromic ink area 118 and the user identification area 114 may have any predefined aspect ratio between each other. For instance, the user identification area 114 and the photochromic ink area 118 may have the same size, or the user identification area 114 may be larger than the photochromic ink area 118.

The advantage of realizing the photochromic ink area 118 larger than the user identification area 114 is that, when the photochromic ink is activated by means of light exposure, it is possible to see the effect of the photochromic ink in the color change of the whole image 120. The same advantages hold for the configuration where the photochromic ink area 118 and the user identification area 114 have the same size.

According to alternative embodiments of the present invention (not shown), the dimensions of the photochromic ink area 118 may be smaller than the dimensions of the user identification area 114. In this way, when activating the photochromic ink by means of light irradiation, the effect in the color change of the photochromic ink may be visible only in a small portion of the image 120 which is aligned with the photochromic ink area 118.

Moreover, it is clear that, even if the laminated structure 100 has been described as comprising the first layer 112, the second layer 116 and, optionally, one or more intermediate layers 132 and 134, it could comprise additional layers directly laminated to the first layer 112 and/or to the second layer 116.

Finally, those fields considered known to the skilled person have not been described to avoid covering in a useless way the described invention. For example, the physical principles of the photochromic ink have not been described, because they are considered to be known to the skilled person.

Reference numbers:

100': structure for a security document

100: laminated structure for a security document

110: stacked structure

112: first layer

114: user identification area

116: second layer

118: photochromic ink area

120: user's image

122: profile of the user

124: background of the image

132, 134: intermediate layers

200: security document

202, 204: layers of the security document

210: overlay layer

CLAIMS

1. A structure (100') for a security document comprising:
 - a first layer (112) comprising a user identification area (114) for forming an image (120) of a user, and
 - a second layer (116) including a photochromic ink area (118) comprising photochromic ink, wherein said photochromic ink area (118) is aligned in correspondence with said user identification area (114).
2. The structure (100') for a security document according to claim 1, wherein said photochromic ink is a UV photochromic ink.
3. A laminated structure (100) for a security document comprising the structure (100') for a security document according to claim 1 or 2, wherein said first layer (112) and said second layer (116) are laminated together.
4. The laminated structure (100) for a security document according to claim 3, wherein said first layer (112) is directly attached to said second layer (116).
5. The laminated structure (100) for a security document according to claim 3 further comprising one or more intermediate layers (132, 134) placed between said first layer (112) and said second layer (116), so that said first layer (112) is indirectly attached to said second layer (116).
6. A security document (200) comprising:
 - the laminated structure (100) according to any one of claims 3 to 5;
 - an image (120) of a user formed in said user identification area (114).
7. The security document (200) according to claim 6 further comprising an overlay layer (210) laminated to said laminated structure (100) so as to cover said image (120).
8. A method for forming a structure (100') for a security document comprising the following steps:
 - a) Providing a first layer (112) comprising a user identification area (114) for forming an image (120) of a user;

- b) Providing a second layer (116) including a photochromic ink area (118) comprising photochromic ink;
 - c) Aligning said first layer (112) and said second layer (116) so that said photochromic ink area (116) is placed in correspondence with said user identification area (114).
9. The method of claim 8 further comprising the following step:
- d) Laminating said first layer (112) and said second layer (116) together so as to form a laminated structure (100).
10. The method of claim 8 further comprising the following steps:
- e) Providing one or more intermediate layers (132, 134) between said first layer (112) and said second layer (116);
 - f) Laminating said first layer (112), said second layer (116) and said intermediate layers (132, 134) together so as to form a stacked laminated structure (100).
11. A method for forming a security document (200) comprising:
- g) Forming a laminated structure (100) according to claim 9 or 10;
 - h) Generating an image (120) of a user on said user identification area (114).
12. The method for forming a security document (200) according to claim 11, further comprising the step of laminating an overlay layer (210) to said laminated structure (100) so as to cover said image (120).
13. A method for operating a security document (200) according to claim 6 or 7, comprising the following steps:
- i) Illuminating said security document (200) with a light source, for instance a UV source;
 - j) Inducing a temporary color-change in at least one part of said image (120), preferably in the background of said image (120).

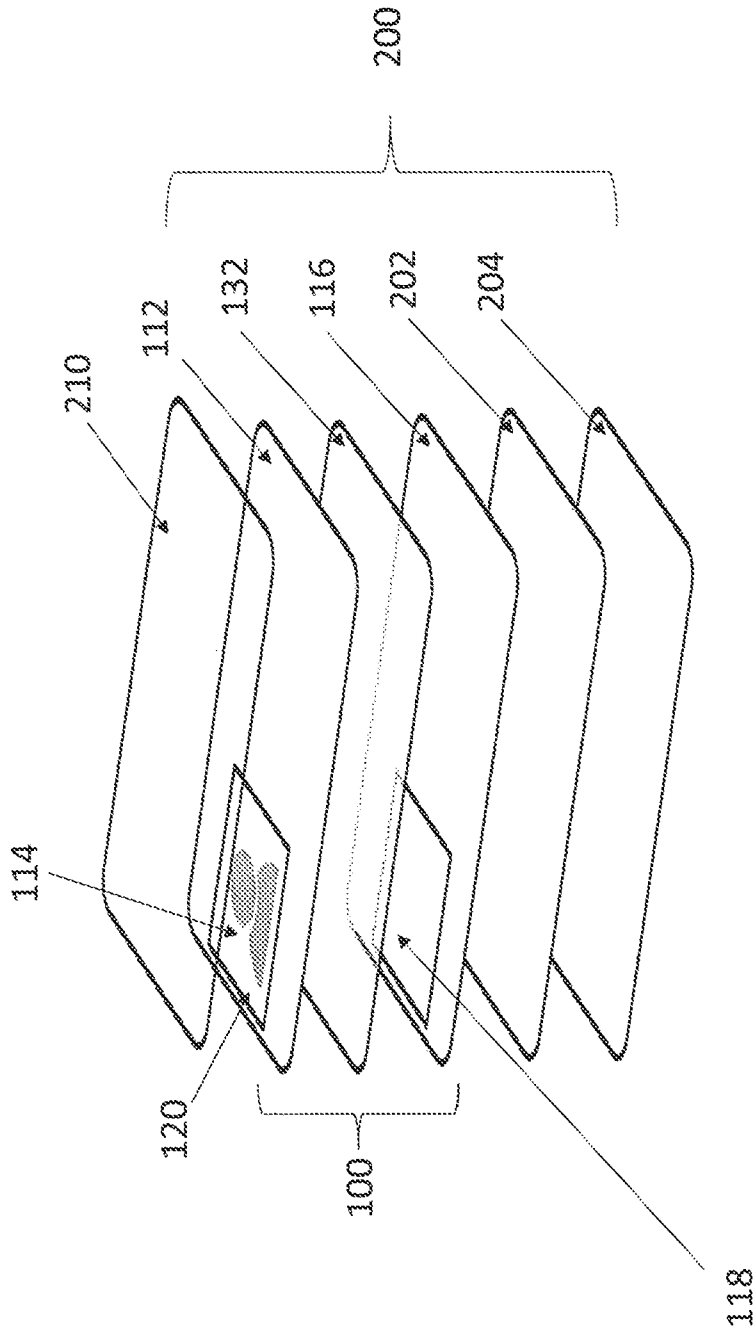

FIG. 1

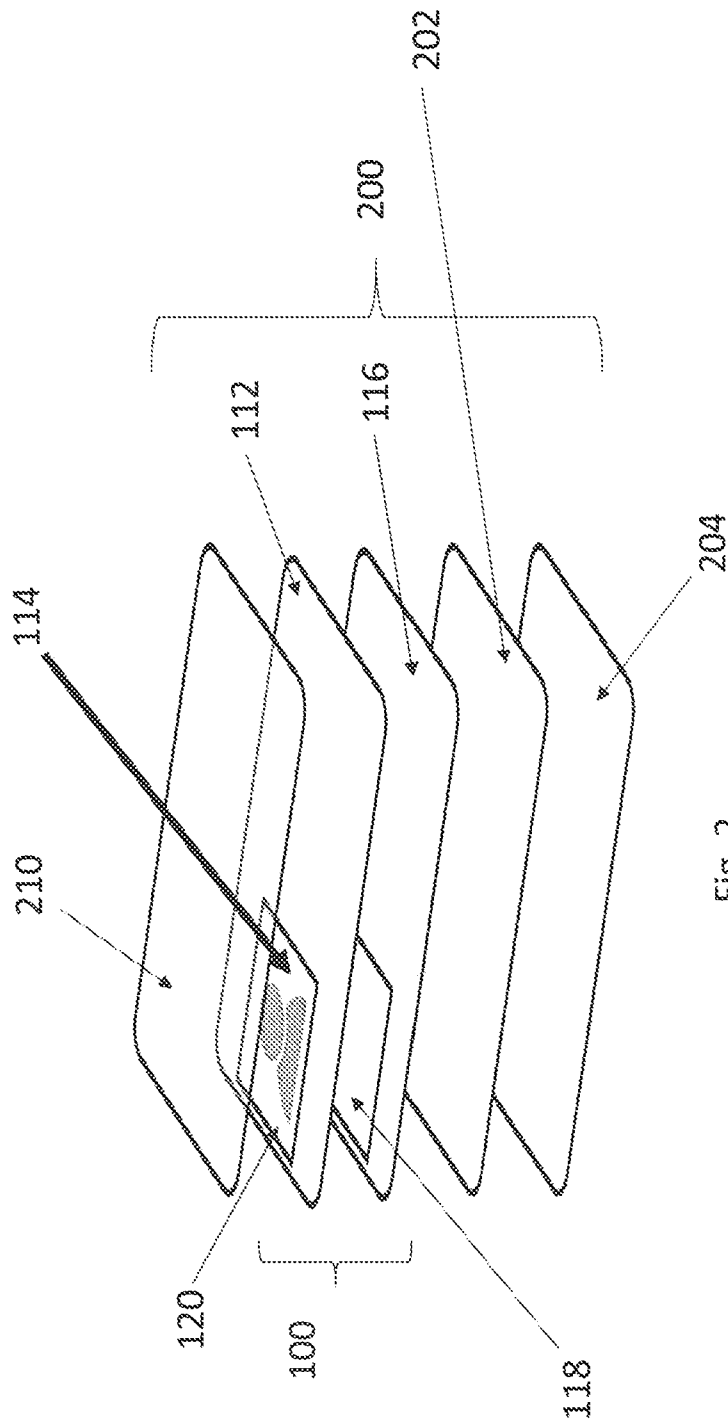

FIG. 2

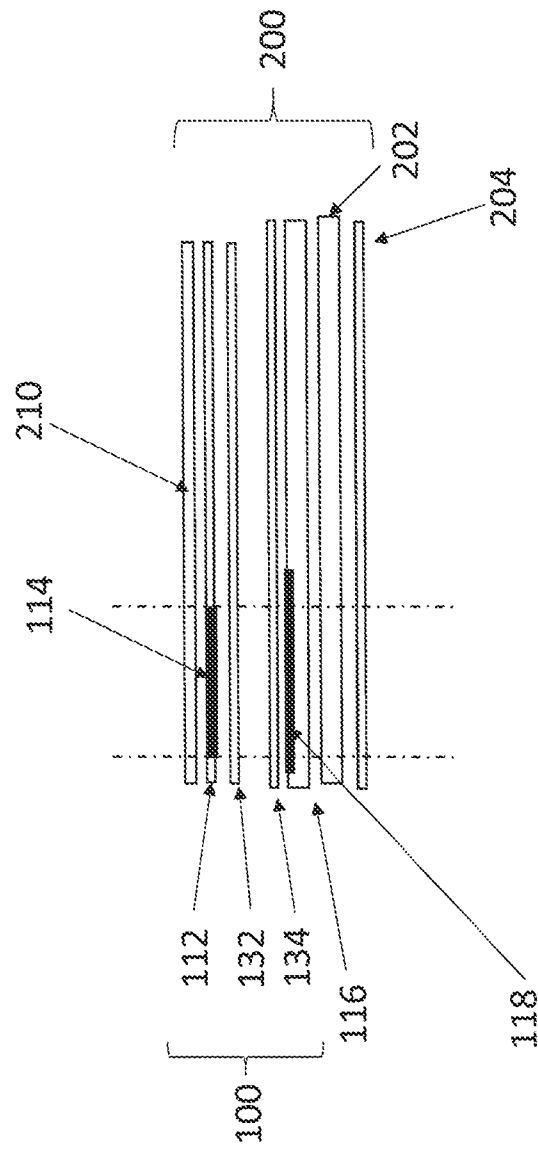

Fig. 3

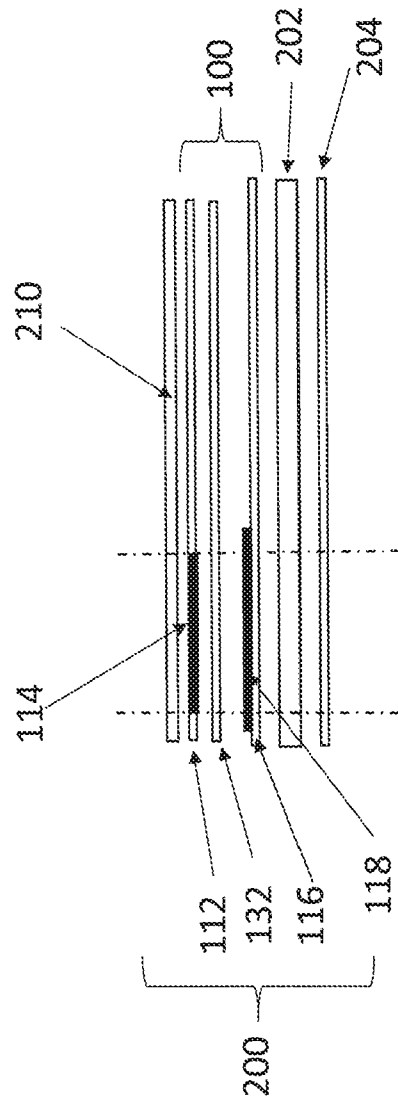

FIG. 4

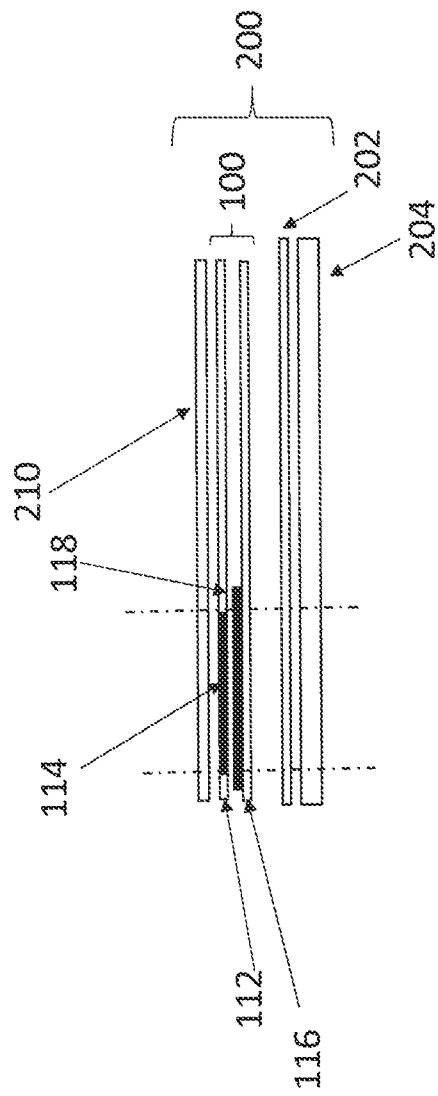

FIG. 5

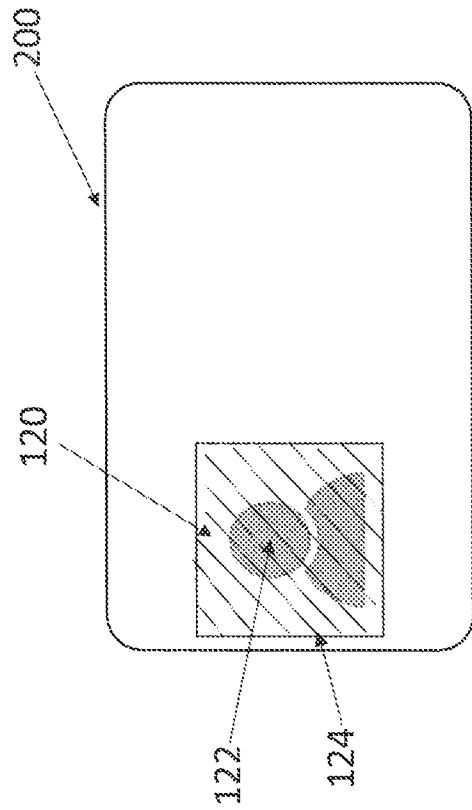

Fig. 6B

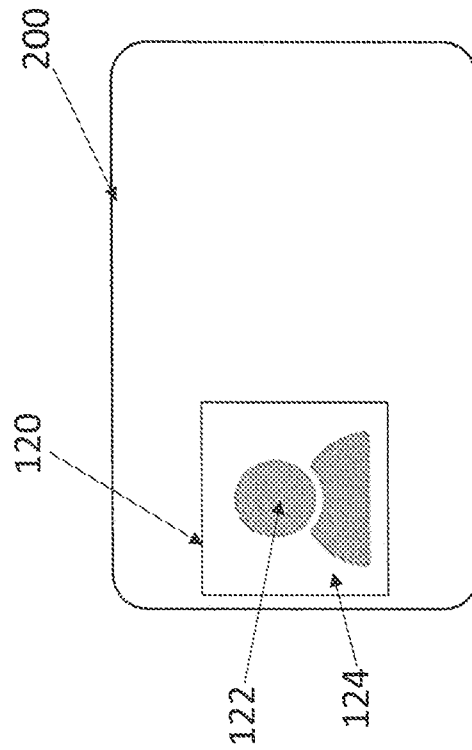

Fig. 6D

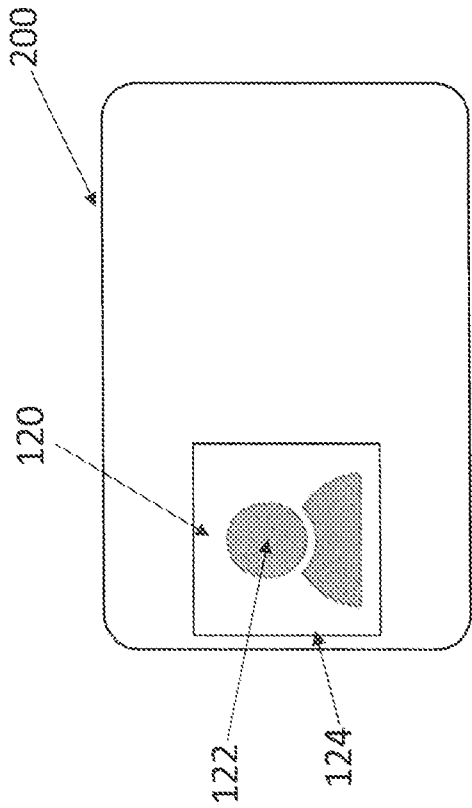

Fig. 6A

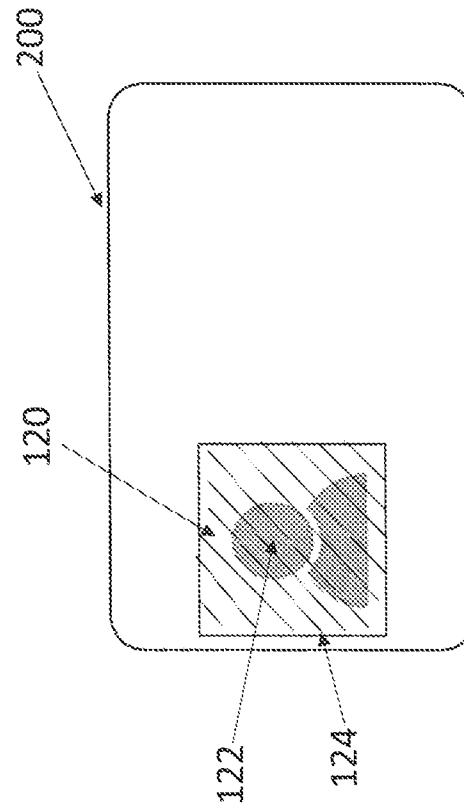

Fig. 6C

INTERNATIONAL SEARCH REPORT

International application No PCT/IB2024/000297

A. CLASSIFICATION OF SUBJECT MATTER
 INV. B42D13/00 B42D25/23 B42D25/24 B42D25/309 B42D25/351
 B42D25/382 B42D25/387 B42D25/41 B42D25/455 B42D25/46

ADD.
 According to International Patent Classification (IPC) or to both national classification and IPC

B. FIELDS SEARCHED
 Minimum documentation searched (classification system followed by classification symbols)
B42D

Documentation searched other than minimum documentation to the extent that such documents are included in the fields searched

Electronic data base consulted during the international search (name of data base and, where practicable, search terms used)
EPO-Internal, WPI Data

C. DOCUMENTS CONSIDERED TO BE RELEVANT

Category*	Citation of document, with indication, where appropriate, of the relevant passages	Relevant to claim No.
X	EP 4 000 940 A1 (IDEMIA FRANCE [FR]) 25 May 2022 (2022-05-25) paragraph [0073] - paragraph [0178]; claims 1-10; figures 1-7 -----	1-13
X	WO 2014/029686 A1 (BAYER MATERIALSCIENCE AG [DE]) 27 February 2014 (2014-02-27)	1-4,8,9
Y	page 28, line 6 - page 35, line 7; claims 1-14; figures 4-7 -----	6,7, 10-13
Y	WO 2009/056352 A1 (BUNDESDRUCKEREI GMBH [DE]; MUTH OLIVER [DE] ET AL.) 7 May 2009 (2009-05-07) page 34, line 8 - page 39, line 28; claims 1-47; figures 1-8 -----	6,7, 10-13
	-/-	

Further documents are listed in the continuation of Box C. See patent family annex.

* Special categories of cited documents :

"A" document defining the general state of the art which is not considered to be of particular relevance "E" earlier application or patent but published on or after the international filing date "L" document which may throw doubts on priority claim(s) or which is cited to establish the publication date of another citation or other special reason (as specified) "O" document referring to an oral disclosure, use, exhibition or other means "P" document published prior to the international filing date but later than the priority date claimed	"T" later document published after the international filing date or priority date and not in conflict with the application but cited to understand the principle or theory underlying the invention "X" document of particular relevance; the claimed invention cannot be considered novel or cannot be considered to involve an inventive step when the document is taken alone "Y" document of particular relevance; the claimed invention cannot be considered to involve an inventive step when the document is combined with one or more other such documents, such combination being obvious to a person skilled in the art "&" document member of the same patent family
--	--

Date of the actual completion of the international search 23 September 2024	Date of mailing of the international search report 08/10/2024
---	---

Name and mailing address of the ISA/ European Patent Office, P.B. 5818 Patentlaan 2 NL - 2280 HV Rijswijk Tel. (+31-70) 340-2040, Fax: (+31-70) 340-3016	Authorized officer Seiler, Reinhold
--	---

INTERNATIONAL SEARCH REPORT

International application No
PCT/IB2024/000297

C(Continuation). DOCUMENTS CONSIDERED TO BE RELEVANT		
Category*	Citation of document, with indication, where appropriate, of the relevant passages	Relevant to claim No.
X	EP 2 308 930 A1 (3DTL INC [US]) 13 April 2011 (2011-04-13) paragraph [0014] - paragraph [0073]; claims 1-15; figures 1-16 -----	1, 2, 8

INTERNATIONAL SEARCH REPORT

Information on patent family members

International application No

PCT/IB2024/000297

Patent document cited in search report	Publication date	Patent family member(s)	Publication date
EP 4000940	A1	25-05-2022	NONE

WO 2014029686	A1	27-02-2014	CN 104540685 A 22-04-2015
			EP 2888116 A1 01-07-2015
			JP 6309953 B2 11-04-2018
			JP 2015531705 A 05-11-2015
			KR 20150047487 A 04-05-2015
			RU 2015109872 A 10-10-2016
			TW 201427841 A 16-07-2014
			US 2015220057 A1 06-08-2015
			WO 2014029686 A1 27-02-2014

WO 2009056352	A1	07-05-2009	AU 2008317837 A1 07-05-2009
			CA 2703749 A1 07-05-2009
			CN 101980875 A 23-02-2011
			DE 102008012419 A1 07-05-2009
			EP 2209653 A1 28-07-2010
			ES 2464531 T3 03-06-2014
			KR 20100099101 A 10-09-2010
			PL 2209653 T3 30-09-2014
			RU 2010121972 A 10-12-2011
			US 2010295290 A1 25-11-2010
			WO 2009056352 A1 07-05-2009

EP 2308930	A1	13-04-2011	AT E486911 T1 15-11-2010
			EP 1926781 A2 04-06-2008
			EP 2308929 A1 13-04-2011
			EP 2308930 A1 13-04-2011
			EP 2308931 A1 13-04-2011
			EP 2316660 A2 04-05-2011
			EP 2322580 A1 18-05-2011
			EP 2327744 A2 01-06-2011
			ES 2355269 T3 24-03-2011
			ES 2533231 T3 08-04-2015
			ES 2643617 T3 23-11-2017
			ES 2643637 T3 23-11-2017
			PL 2327744 T3 28-09-2018
			RS 51720 B 31-10-2011
			US 2006237541 A1 26-10-2006
			US 2012080877 A1 05-04-2012
			US 2015014981 A1 15-01-2015
			WO 2007005354 A2 11-01-2007
