

W. B. KNAPP.  
SHOCK ABSORBER.  
APPLICATION FILED AUG. 20, 1909.

Patented Jan. 17, 1911.

982,008.

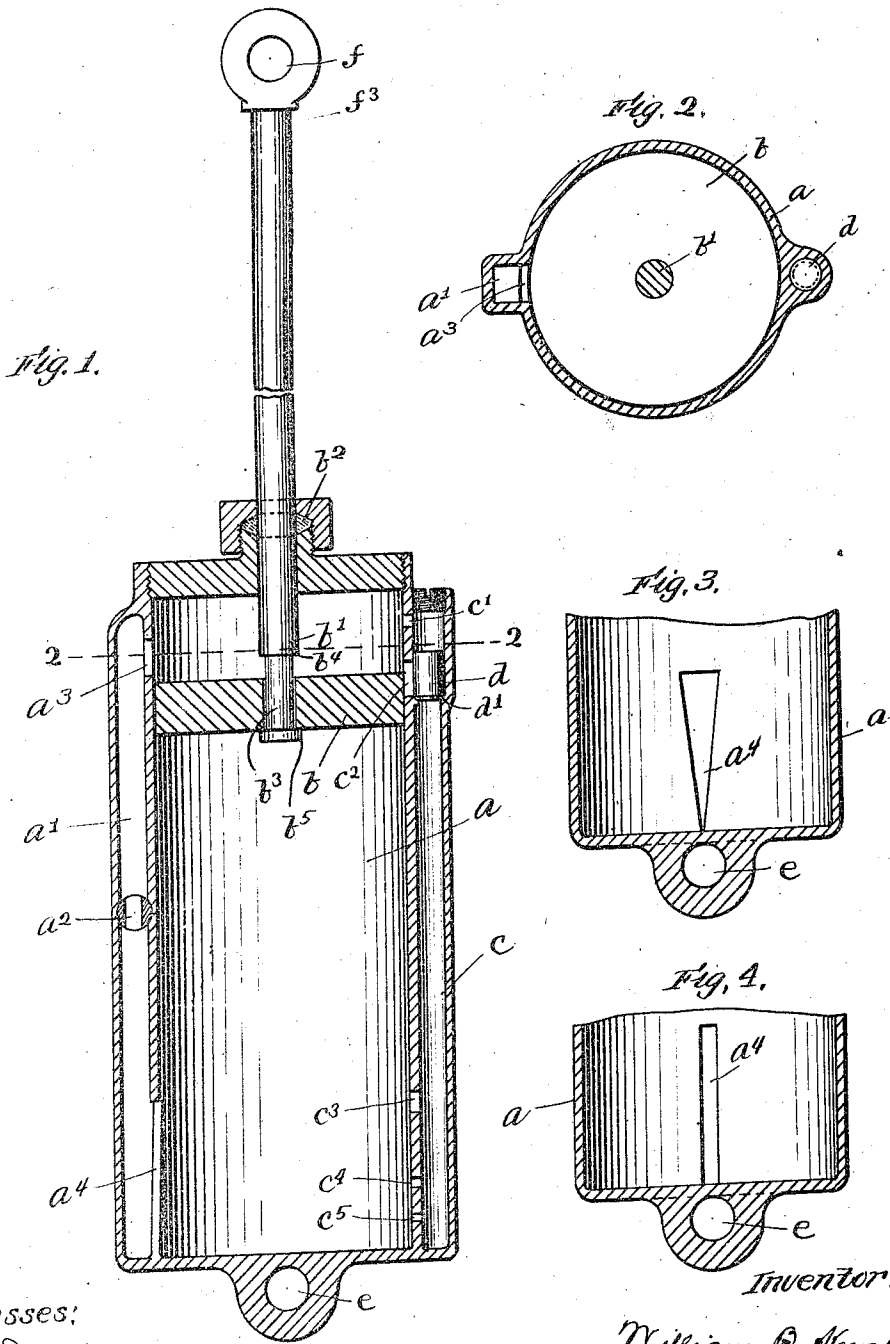

Witnesses:  
H. B. Davis.  
Cynthia Doyle.

Inventor:  
William B. Knapp.  
By Jones & Hannivan  
attys.

# UNITED STATES PATENT OFFICE.

WILLIAM BRUCE KNAPP, OF STONEHAM, MASSACHUSETTS, ASSIGNOR TO ANNIE L. KNAPP, OF STONEHAM, MASSACHUSETTS.

## SHOCK-ABSORBER.

982,008.

Specification of Letters Patent. Patented Jan. 17, 1911.

Application filed August 20, 1909. Serial No. 513,731.

To all whom it may concern:

Be it known that I, WILLIAM B. KNAPP, of Stoneham, county of Middlesex, State of Massachusetts, have invented an Improvement in Shock-Absorbers, of which the following is a specification.

This invention relates to shock-absorbers for automobiles and the like, of the type comprising a cylinder and piston, connected one with the running-gear and the other with the frame of the vehicle, and having means for establishing open communication between the opposite end-portions of the cylinder, permitting movement of the piston and cylinder toward and from each other, and having means for restraining such movements.

The object of the invention is to provide the cylinder with a continuously open main by-pass, permitting movements of the cylinder and piston toward and from each other, and also with an improved form of automatically-controlled by-pass by which movements of the cylinder and piston toward and from each other are controlled in the following manner: Upon the occurrence of a feeble shock their movements toward each other will be unrestrained and their return movements restrained, and upon the occurrence of a violent shock their movements toward each other will be unrestrained during the first part of the stroke, and gradually restrained during the last part thereof until checked, and their return movements will be unrestrained during the first part of the stroke and severely restrained during the last part thereof until checked.

The invention also has for its object to movably connect the imperforate piston with the piston-rod to provide for a short independent movement of said rod, which is of particular advantage upon the occurrence of feeble shocks, but is also of advantage at other times.

Figure 1 is a longitudinal vertical section of a shock-absorber embodying this invention. Fig. 2 is a cross-section of the shock-absorber shown in Fig. 1 taken on the dotted line 2-2. Fig. 3 is a sectional detail of the lower end-portion of the cylinder showing the lowermost port of the main by-pass. Fig. 4 is a sectional detail of the lower end-portion of the cylinder showing modified

forms of ports for the lower ends of both the main by-pass and automatically controlled by-pass.

As here shown *a* represents a hollow cylinder, closed at its ends, and *b* a piston contained therein and attached to a piston-rod *b'*, which extends through a suitable stuffing-box *b''*. The cylinder has a by-pass connection between its upper and lower ends, comprising as here shown, two by-passes. Along the wall of the cylinder *a*, a main by-pass *a'* is formed or provided which extends from end to end of the cylinder or thereabout, which is open at both ends into said cylinder, and said by-pass is provided with a manually operated regulating-valve *a''*. The port *a'''* leading from the upper end of the main by-pass to the cylinder may be circular or of any other shape, and the port *a''''* leading from the lower end of the main by-pass to the cylinder may be made as an inverted triangle, see Fig. 3, having its upper end made substantially as wide as the by-pass, and having its sides gradually converging toward the lower end, or said lower port may be made as a long slot having parallel sides, see Fig. 4. Also along the wall of the cylinder another by-pass *c* is formed or provided, which extends from end to end of the cylinder or thereabout, which is adapted to be automatically controlled, and is employed for controlling the movements of the cylinder and piston toward and from each other. As shown in Fig. 1, said by-pass *c* has several ports of various sizes, arranged along its length, all leading to the cylinder, as *c'*, *c''*, *c'''*, *c''''* and *c''''''*. At the upper end-portion of said by-pass *c* a check-valve *d*, of any suitable construction, is provided, which may be made as a cylinder or ball, and, as here shown, said by-pass *c* has an enlarged portion provided with a seat *d'*, on which said check-valve normally rests, to close the by-pass. Said check-valve is moved by variations in pressure as the piston and cylinder are moved relatively to each other. The seat *d'*, is arranged below the port *c''*, so that the check-valve, when seated, occupies a position opposite said port *c''*, or thereabout. The ports *c''*, *c''''* and *c''''''* are arranged at the lower end-portion of the by-pass. As here shown, the port *c''''* is made of a lesser area than the port *c''*, and the port *c''''''* of lesser area than

the port  $c^4$ , and the distance between the ports  $c^4$  and  $c^5$  is less than the distance between the ports  $c^3$  and  $c^4$ , but the sizes of the ports and their relative positions may be varied. Yet it will be understood, that the combined areas of the three ports  $c^3$ ,  $c^4$ ,  $c^5$ , shall be as great or greater than the area of the port  $c^2$ , and the combined areas of the ports  $c^4$  and  $c^5$  shall be less than the area of the port  $c^3$ .

The lower end of the cylinder has a connection adapting it to be connected with the running-gear, and the piston-rod has at its extremity a connection adapting it to be connected with the frame. Said piston-rod, however, is preferably made to move a short distance without moving the piston, as for instance upon the occurrence of a very feeble shock, and, as here shown, the piston is arranged loosely on, and so as to slide on the rod for a short distance. The piston-rod has its lower end formed with a reduced portion  $b^3$ , and with shoulders  $b^4$  and  $b^5$ , to thus provide for a short movement of the rod independently of the piston. By loosely connecting the piston to its rod, as here shown, it will be observed that on a full stroke of the piston it will not strike against the lower end of the cylinder for the reason that the end of the piston rod projects below it for a short distance at such time.

Normally the piston  $b$  occupies a position at or near the upper end of the cylinder, as shown in Fig. 1, and when the piston and cylinder are suddenly moved toward each other a short distance, due to a feeble shock, the check-valve in the by-pass  $c$  opens, and the liquid contained in the cylinder is forced through the by-pass  $c$ , so that such short movements of the piston and cylinder in a direction toward each other are unrestrained. During the return movements of said parts the check-valve closes on its seat, closing the by-pass  $c$ , consequently said return movements of the parts are restrained.

When the piston and cylinder are suddenly moved toward each other for a long distance, due to a violent shock, the piston moves, presumably, to or near the lower end of the cylinder, and the check-valve opens, and the movements are unrestrained until the piston passes the port  $c^3$ , when the combined areas of the ports leading from the lower end-portion of the cylinder being materially reduced, further movements of the parts are restrained, and when the piston passes the port  $c^4$  and closes over a portion of the port  $a^4$ , said movements are still further restrained, and so on until the piston passes all the ports, and at the end of a long stroke the piston is checked by a yielding cushion formed at the lower end of the cylinder. Thus movements of the piston and cylinder in a direction toward each other are

unrestrained during the first part of the stroke, and more and more restrained during the last part thereof, until checked. On the return movements of the parts the check-valve closes, but during the first part of said return movements they are unrestrained for the reason that the ports above and below the piston are open, permitting passage of the liquid, and such unrestrained movements of the parts continue until the piston closes the port  $c^3$ , when the remaining portions of said return movements are severely restrained. It will be noted that the ports  $c^3$ ,  $c^4$  and  $c^5$  extend over a distance greater than the thickness of the piston thereby providing openings both above and below the piston.

In lieu of providing a triangular-shaped port  $a^4$ , as shown in Fig. 3, at the lower end of the by-pass  $a'$ , said port may be made as a parallel-sided slot, see Fig. 4; and in lieu of providing the several ports  $c^3$ ,  $c^4$ ,  $c^5$ , at the lower end of the cylinder leading to the by-pass  $c$ , a similar parallel-sided slot may be employed, it being understood that I do not limit my invention to the shape or number of the ports at the lower end of the by-pass  $c$  as long as they extend over a distance greater than the thickness of the piston.

Having thus described my invention, what I claim as new and desire to secure by Letters Patent is:—

1. A shock-absorber comprising a cylinder and imperforate piston, said cylinder having two by-passes extending from end to end of it, each having a port at its upper end, and one having a port at its lower end, and the other having a series of ports at its lower end, the combined areas of which are as great as the area of the port at the upper end of the by-pass, the ports of said series being so arranged as to permit the piston to move over them *seriatim*, whereby the areas of the ports below the piston gradually become less than the areas of the ports above the piston, including the port at the upper end of the by-pass, to restrain and finally check movement of the piston, a regulating-valve contained in one of said by-passes, a valve-seat arranged in the other by-pass and a check-valve movable toward and from said seat, substantially as described.

2. A shock-absorber comprising a cylinder and an imperforate piston, said cylinder having a by-pass between its upper and lower ends, a check-valve arranged in said by-pass permitting unrestrained movement of the piston during the first part of its down stroke and restrained movement thereof during the last part of its up stroke, the lower end portion of said by-pass being in open communication with the cylinder for a distance greater than the thickness of the piston, whereby the area of open communication with the cylinder below the piston

gradually becomes less than the area above the piston as the piston moves in a downward direction over the lower end portion of the by-pass upon the occurrence of a violent shock, thereby gradually restraining downward movement of the piston more and more during the last part of its stroke and permitting unrestrained movement of the piston during the first part of its return

stroke as compared with the last part of its return stroke, substantially as described.

In testimony whereof, I have signed my name to this specification, in the presence of two subscribing witnesses.

WILLIAM BRUCE KNAPP:

Witnesses:

B. J. NOYES,  
H. B. DAVIS.