



(12) **DEMANDE DE BREVET CANADIEN
CANADIAN PATENT APPLICATION**

(13) **A1**

(22) Date de dépôt/Filing Date: 2016/08/22

(41) Mise à la disp. pub./Open to Public Insp.: 2018/02/22

(51) Cl.Int./Int.Cl. *H02S 20/10* (2014.01),
H02S 40/32 (2014.01), *H02S 40/34* (2014.01)

(71) Demandeur/Applicant:
BRADLEY, PATRICK MICHAEL, CA

(72) Inventeur/Inventor:
BRADLEY, PATRICK MICHAEL, CA

(74) Agent: BERUBE PATENT SERVICES

(54) Titre : **MODULE DE LOGEMENT CAPTEUR SOLAIRE EN TOTEM**

(54) Title: **TOTEM POLE SOLAR CAPTURE HOUSING UNIT**

(57) **Abrégé/Abstract:**

The Totem Pole Solar Capture Housing is an improved design for a photo voltaic module enclosure. It is cylindrical in shape to capture the maximum amount of solar radiation on the housing's surface transferred to the module for conversion to electricity, and eliminates positional orientation. The cylindrical glass outer shell exposes one half of its circumference to solar radiation on contact. Used singly or in multiples interconnected together, one atop the other and erected vertically on a foot print of one square meter. The inner photo voltaic module support core diameter and height can be sized to fit modules of different electrical outputs. The hollow center of the support core acts as the wiring channel to the base. Assembly couplings form the top and bottom of the enclosure and are critical in joining multiple enclosures into one vertical electrical output enhanced assembly.

Abstract

The Totem Pole Solar Capture Housing is an improved design for a photo voltaic module enclosure. It is cylindrical in shape to capture the maximum amount of solar radiation on the housing's surface transferred to the module for conversion to electricity, and eliminates positional orientation. The cylindrical glass outer shell exposes one half of its circumference to solar radiation on contact. Used singly or in multiples interconnected together, one atop the other and erected vertically on a foot print of one square meter. The inner photo voltaic module support core diameter and height can be sized to fit modules of different electrical outputs. The hollow center of the support core acts as the wiring channel to the base. Assembly couplings form the top and bottom of the enclosure and are critical in joining multiple enclosures into one vertical electrical output enhanced assembly.

INVENTOR: Patrick Michael Bradley

218 St. Felix Street
Cornwall, ON K6H 5A5
Canada
(613) 938-9231 pbradley14@cogeco.ca

TOTEM POLE SOLAR CAPTURE HOUSING UNIT

1 of 4

Additional to the abstract

TOTEM POLE SOLAR CAPTURE HOUSING UNIT

The Totem Pole housing unit consists of the following components:

- 1) A steel round base
- 2) Optional load bearing plug
- 3) Assembly couplings
- 4) Stabilizing and assembly metal draw bands
- 5) Inner core photovoltaic module support tube
- 6) Tempered low iron glass (or a material with similar qualities) outer cylinder
- 7) Steel threaded assembly support rods
- 8) Press fit domed cap
- 9) Optional compression gaskets
- 10) Rubber O rings
- 11) Nuts, bolts and washers

The Totem Pole Solar Capture Housing Unit using the above components is a vertically erected cylindrical assembly designed to provide maximum solar gain onto a flexible wrap-around photovoltaic module (NB. The flexible wrap-around photovoltaic module is NOT to be included in this request for patent) mounted onto a support tube enclosed within the housing unit. The vertical position of the unit (units) allows for the optimum amount of available solar radiation to be received each day regardless of the sun's East to West movement or the sun's position relative to the horizon. As the sun engages the vertical cylinder one half of the circumference's width and the full height of the photovoltaic module is engaged converting the sun's radiation to electricity. As the sun moves East to West the solar contact on the photovoltaic module progresses around

the circumference of the module maintaining full contact with half of the module's circumference and the full height of the module with no fall-off of solar radiation at the edges.

The Totem Pole system is designed to allow additional units to be stacked one atop the other with no increase in footprint for the cumulative electrical output of the combined photovoltaic units making it ideal for limited space installations to provide superior electrical gain per square area.

The following is a description of the function and relationship of the various components of the Totem Pole photovoltaic housing unit. Measurements are approximate based on a flexible photovoltaic module of 1640 mm long by 992 mm high which again is not meant to be included in this patent application.

1) STEEL ROUND BASE

A steel base approximately 550 mm in diameter by a height of 200 mm augmented by a load bearing ring welded to the top of the base and supported by gussets. The open center of the ring allows for the passage of electrical wiring from the photovoltaic modules electrical wiring above. A wiring access door is provided on the outside of the base with a junction box for connection of wiring to the photovoltaic inverters located elsewhere. Pre-drilled 90 degree tabs projecting outward are welded to the bottom of the round base equally spaced around the circumference for mounting of the base to a solid flat surface. In addition, four pre-drilled 90 degree assembly tabs are welded to the outside of the round base equally spaced 90 degrees apart around the circumference 100 mm down from the top of the base to secure the first assembly coupling.

2) OPTIONAL LOAD BEARING PLUG

A plastic load bearing plug with an open center is installed into the bottom of the first assembly coupling filling the grooves provided for the outer non-reflective glass cylinder and the inner photovoltaic support tube to assist in distributing the weight load of the assembled Totem Pole solar capture housing unit (s).

3) ASSEMBLY COUPLING

The assembly coupling is an 87.5 mm thick plastic ring with a 550mm. diameter equal to the diameter of the steel round base. The top and bottom of the assembly coupling are mirror images identical in all respects. Approximately 8 mm inward from the outside edge of the plastic ring on the top and bottom faces a 37 mm deep groove by a width equal to the thickness of the non-reflective glass cylinder is provided. On the outside wall of this groove and 6 mm down into it a rounded groove is established to provide for the insertion of a moisture barrier O ring. At the bottom of the groove

provided for the non-reflective glass cylinder a compression gasket is inserted to act as a cushion for the glass cylinder. A second groove set inward from the first groove and distanced by an air space and the thickness of the photovoltaic module is established on the top and bottom of the assembly coupling with a depth of 37 mm its width equal to the thickness of the inner core module support. From the inner width of this groove a support shoulder 12 mm wide is established its outer edge marking the beginning of the hollow wiring channel. On the outside vertical surface of the assembly coupling midway between the top and bottom of the assembly coupling a 31 mm wide groove is provided around the circumference its depth approx. 3.2 mm. to be determined by the thickness of the stabilising and assembly draw band for a flush fit.

4) STABILIZING and ASSEMBLY METAL DRAW BAND

The stabilising and assembly metal draw band is sized to fit into the vertical outside groove of the assembly coupling and wrap around the circumference of the assembly coupling. Each end of the draw band is bent outward at a 90 degree angle and pre-drilled to allow for a nut and bolt to draw the band tight to the assembly coupling. Eight (8) pre-drilled 90 degree 25mm.x25mm.x25mm assembly tabs are welded to the outside face of the draw band 45 degrees distance from each and projecting outward, additional to this three (3) metal rings 25mm. in diameter spaced approximately 120 degrees apart are welded to the outside face of the draw band to provide for the connection of stabilising guy wires to ensure the vertical position of the Totem Pole Solar Capture Housing System is maintained.

The first assembly coupling is now ready to be connected to the steel round base. The optional load bearing plug may be inserted into the bottom of the assembly coupling and the steel draw band is loosely attached to the assembly coupling and aligned to the four assembly tabs 25mm.x25mm.x25mm.set 90 degrees apart on the steel base and bolted tight to the assembly coupling. Next four (4) short threaded metal support and assembly rods are used to connect four of the draw band's assembly tabs to the four assembly tabs on the steel base and bolted tight.

5) INNER CORE PHOTOVOLTAIC MODULE SUPPORT TUBE

The inner core module support tube its diameter sized to accommodate a module approximately 1640 mm long by 992 mm high that wraps fully around the inner core support tube's circumference. Two ring discs project outward from the inner core tube each is located 37.5 mm from either end of the support tube to provide additional support for the photovoltaic module. A port hole in the main body of the inner core tube is provided to allow the module wiring into the hollow center and downward to the junction box located in the round base. The 37.5 mm length of the inner core tube

above the upper support ring disc and the 37.5 mm length below the lower support ring disc fit into the inner groove of the upper and lower faces of the assembly couplings.

6) OUTER TEMPERED LOW IRON GLASS CYLINDER

The glass cylinder 1065 mm. high fits into the outside groove of the assembly couplings to a depth of 37.5 mm, its diameter is measured across the assembly coupling from the outside groove of either side of the assembly coupling at the center line.

7) STEEL ASSEMBLY AND SUPPORT RODS

Having installed the second (top) assembly coupling onto the inner core tube and the outer non-reflective glass cylinder a draw band is installed onto the top assembly coupling and loosely tightened then aligned to the remaining assembly tabs of the bottom assembly coupling and tightened firmly. Next four (4) steel threaded rods with a nut run up the threads on each end are fitted into the upper and lower assembly tabs of the upper and lower assembly couplings washers placed and the rod adjusted to project equal length of rod above and below the assembly tabs the nuts are tightened then a second washer and nut are run down either end sandwiching the assembly tabs arresting any up or down movement and adding strength to the unit. Stage one is now complet.

STAGE TWO

Additional housing units may now be assembled atop the first unit utilizing the open grooves of the first unit's top assembly coupling in the same fashion as the initial housing unit's assembly. Once the second unit is installed guy wires are attached to the upper assembly coupling's draw band's three rings and diagonally anchored firmly to a level equal to or below the round base. Every second housing unit installed above the initial two (2) units are similarly supported with guy wires.

8) PRESS FIT DOMED CAP

When sufficient housing units have been installed to provide the desired electrical output and adequate guy wires have been installed to stabilize the vertical position of the assembled housing units a domed cap with a rim extending beyond the top assembly coupling's edge and a sleeve extending 37.5 mm below the rim having a diameter and width equal to the outside groove of the top assembly coupling is inserted into the groove completing the assembly. Vent holes are provided in the sleeve area above the 37.5 mark to vent to the outside between the domed cap and the assembly coupling.

Totem Pole Solar Capture Housing

Inventor: Patrick Michael Bradley 218 St. Felix St. Cornwall, On. K6H 5A5 (613) 938-9231

Pbradley14@cogeco.ca

Claims

The embodiments of the invention in which an exclusive property or privilege is claimed and defined as follows.

- 1 Cylindrical form or shape to enclose or house a photo voltaic module for exposure to solar radiation.
- 2 Vertical erection of a cylindrical photo voltaic module housing unit.
- 3 The same minimal foot print regardless of electrical output from housing unit (s).
- 4 Vertical stance eliminates orientation of housing unit to compensate for suns movement.
- 5 Vertical cylinder has 180 degrees of circumference exposed to suns radiation on contact.
- 6 Radiation contact on vertical cylinder circles around it as sun moves east to west.
- 7 Daily and seasonal positions of the sun track around the vertical cylinder.
- 8 Assembly couplings that locate and support inner core, outer glass cylinder and draw band.
- 9 Assembly couplings that form the top and bottom of the housing unit and part of the wiring channel.
- 10 Assembly couplings that locate and secure the vented domed cap.
- 11 Assembly coupling grooved to locate and secure draw band.
- 12 Draw band bolts securely into provided groove on assembly coupling.
- 13 Draw band has attached outward projecting pre-drilled assembly tabs.
- 14 Assembly tabs are used to join assembly coupling to the steel base and assembly coupling to assembly coupling.
- 15 Assembly couplings are key to mounting multiple housing units one atop the other into a single vertical assembly combining all the individual electrical output routed to the base junction box.
- 16 Draw band has attached metal rings for connection of guy wires which stabilize the assembly and maintain vertical plumb.
- 17 Threaded metal rods, washers, and nuts join and secure initial assembly coupling to the steel base and assembly coupling to assembly coupling.

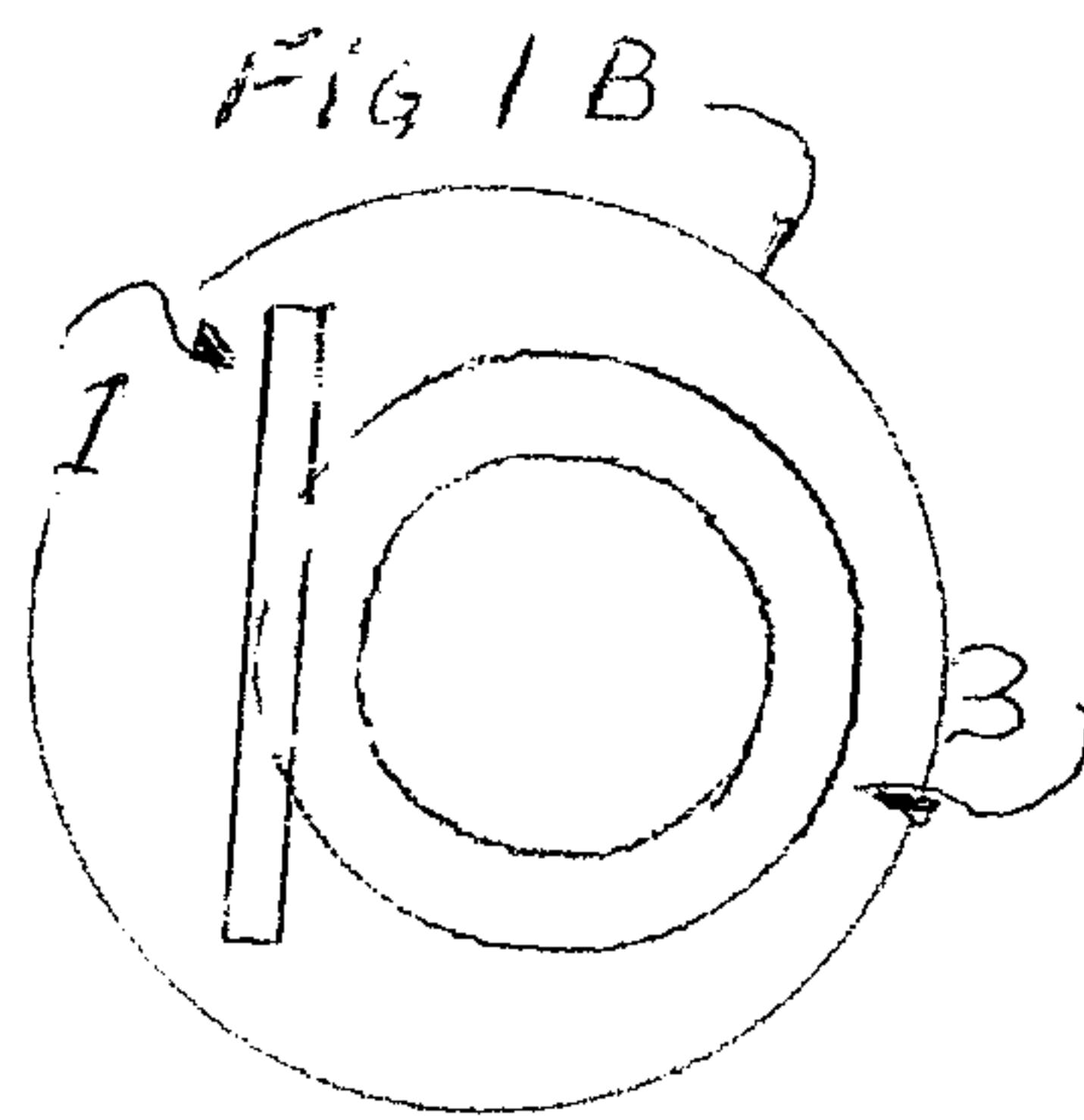
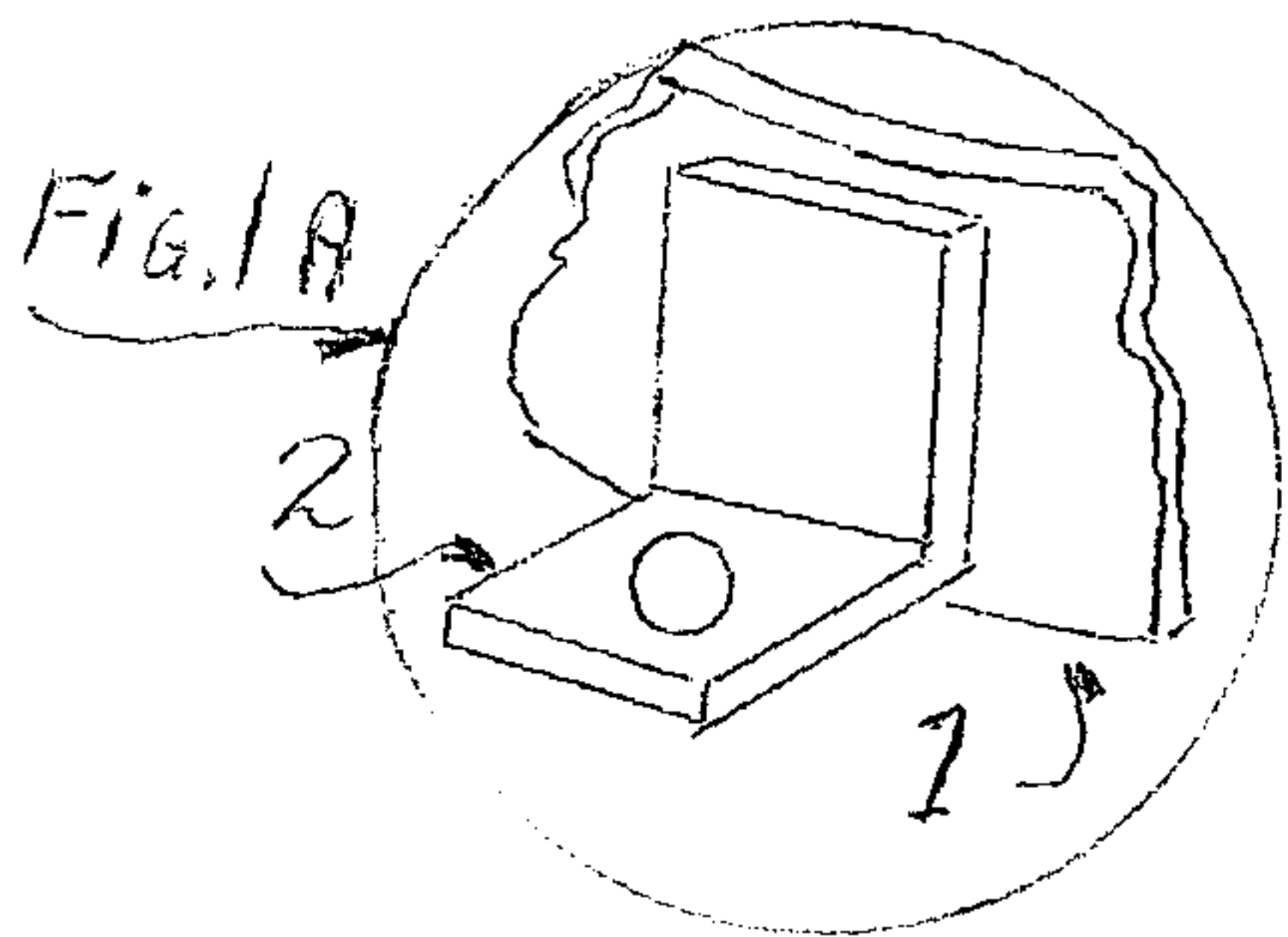

FIG. 1

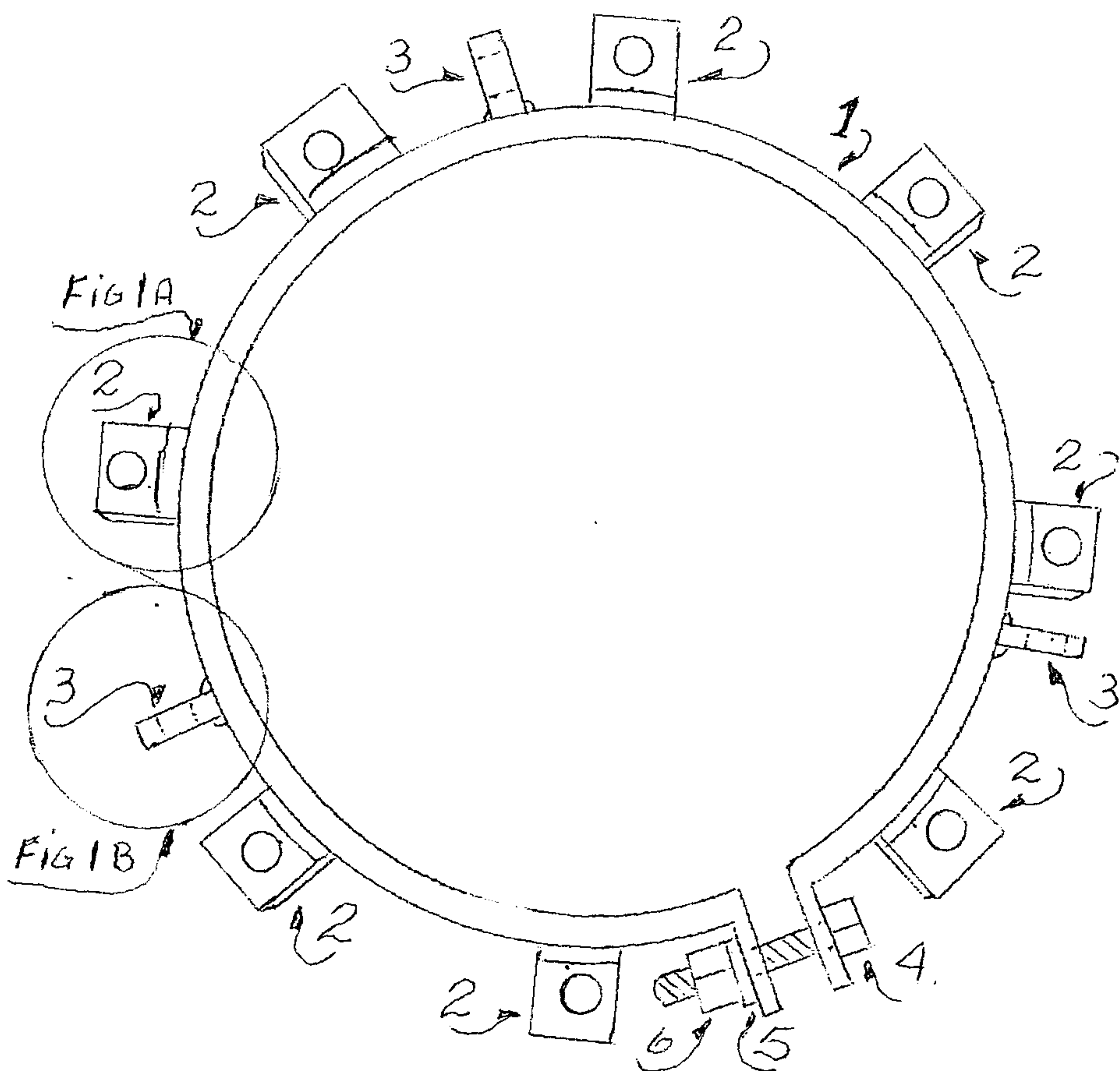

Fig. 2

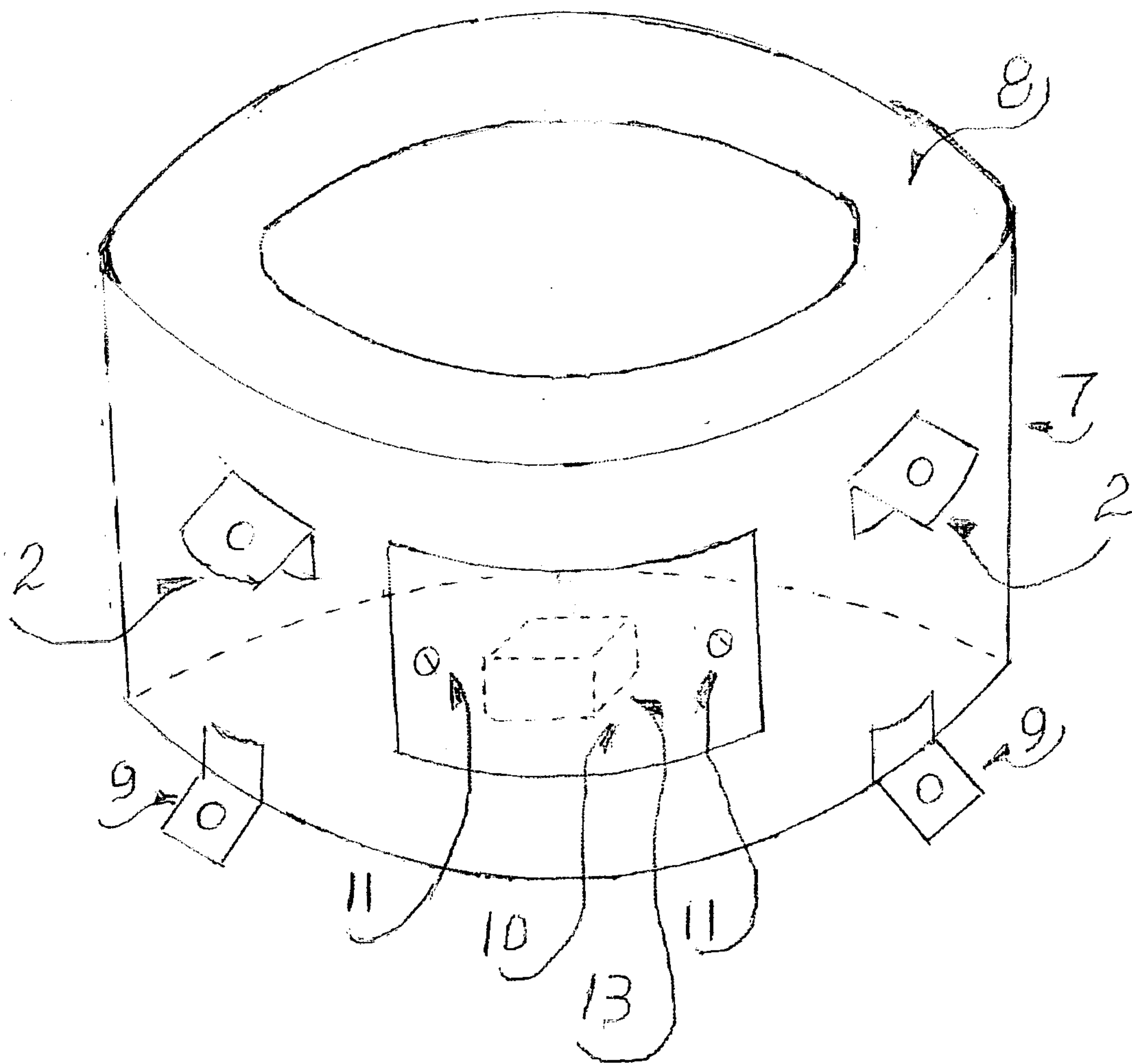

Fig. 3

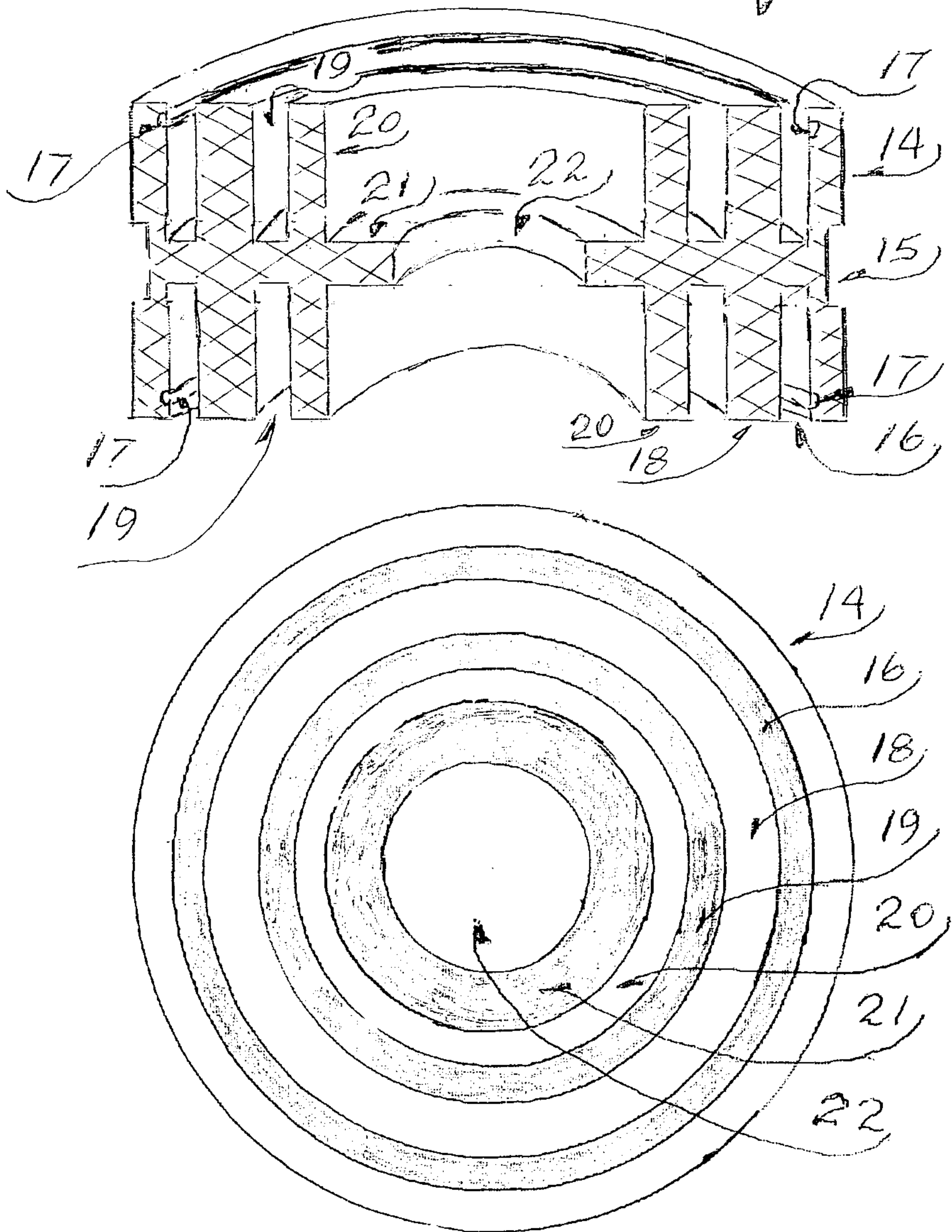

FIG. 4

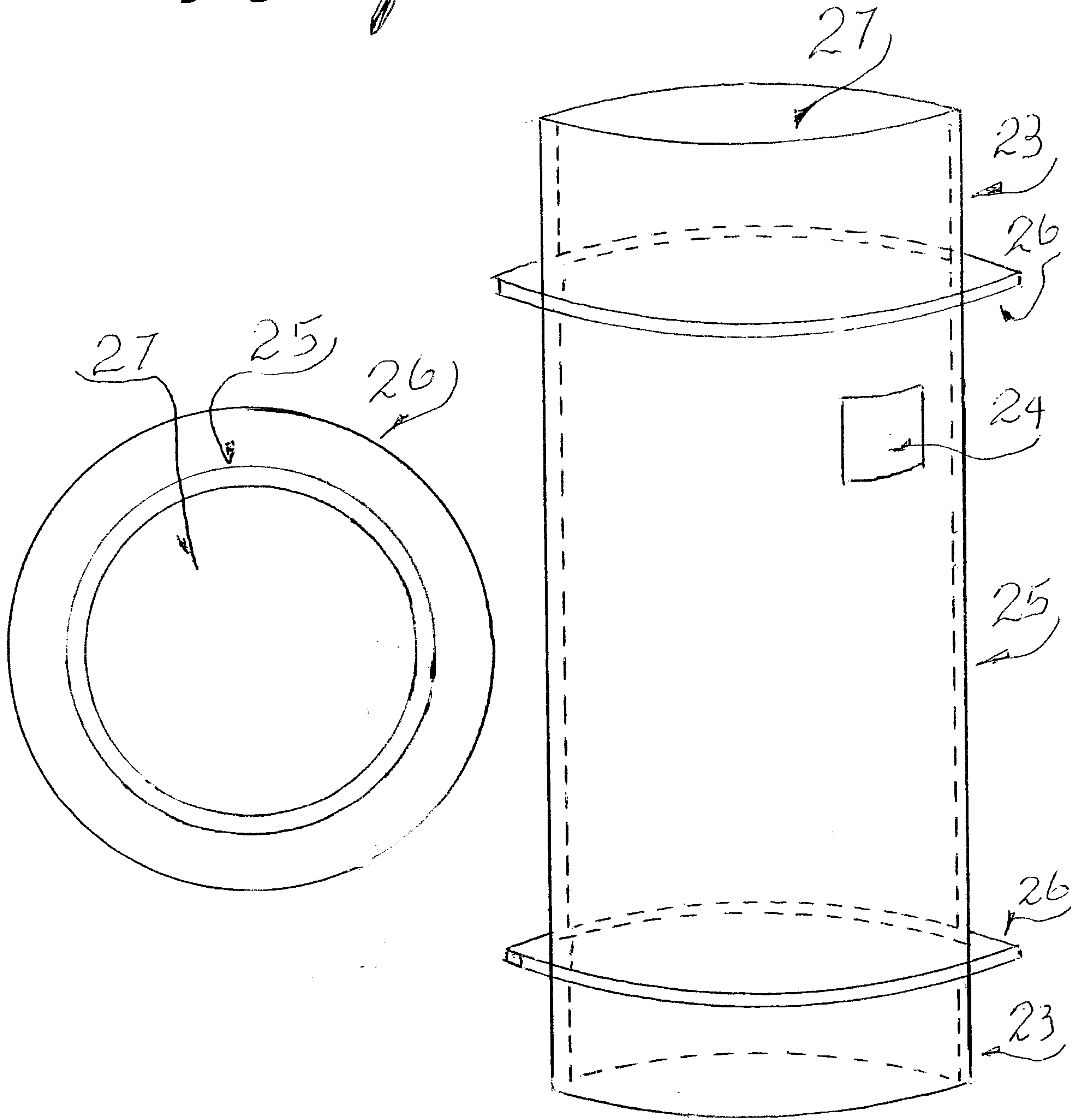

Fig. 5

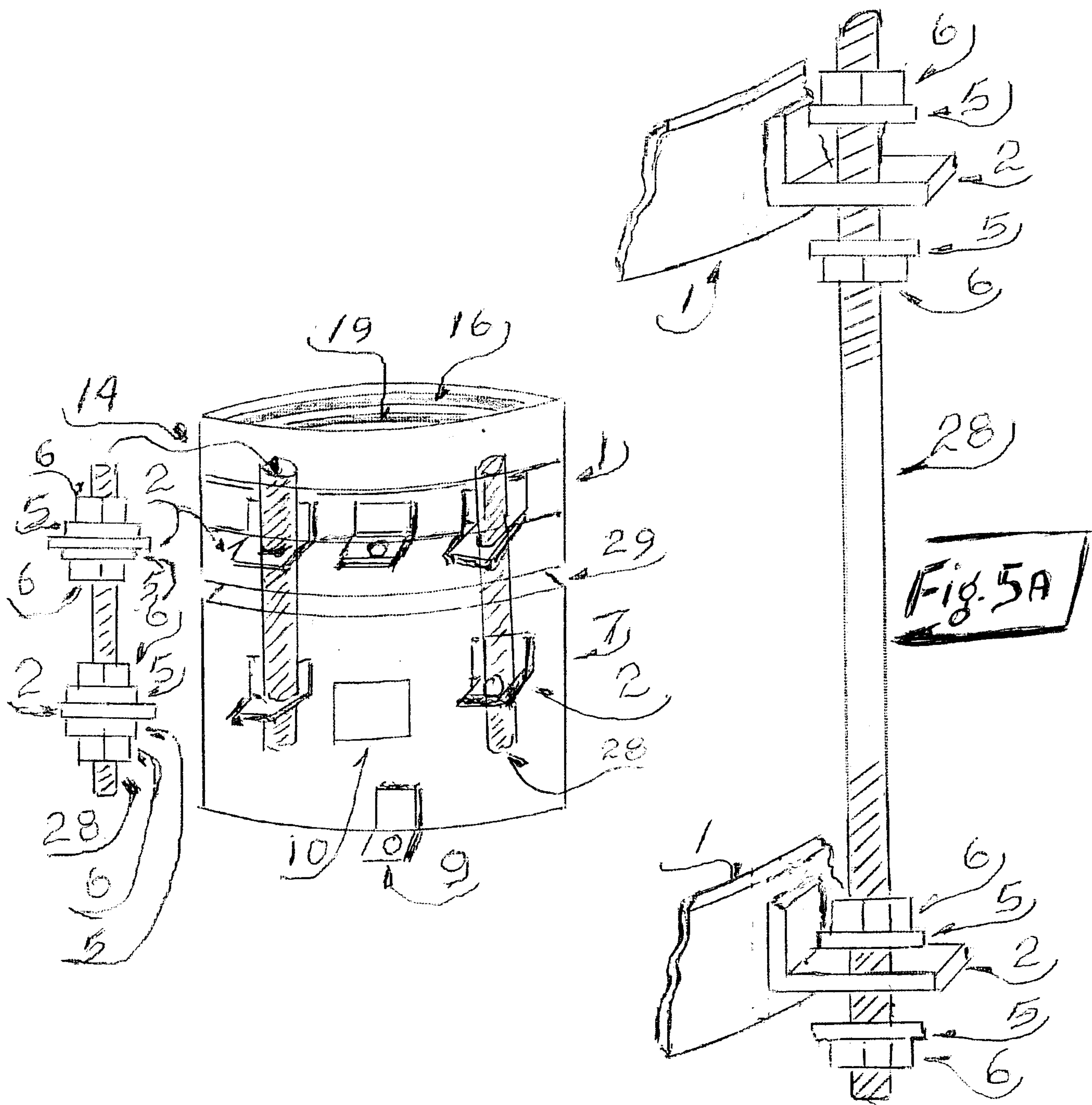
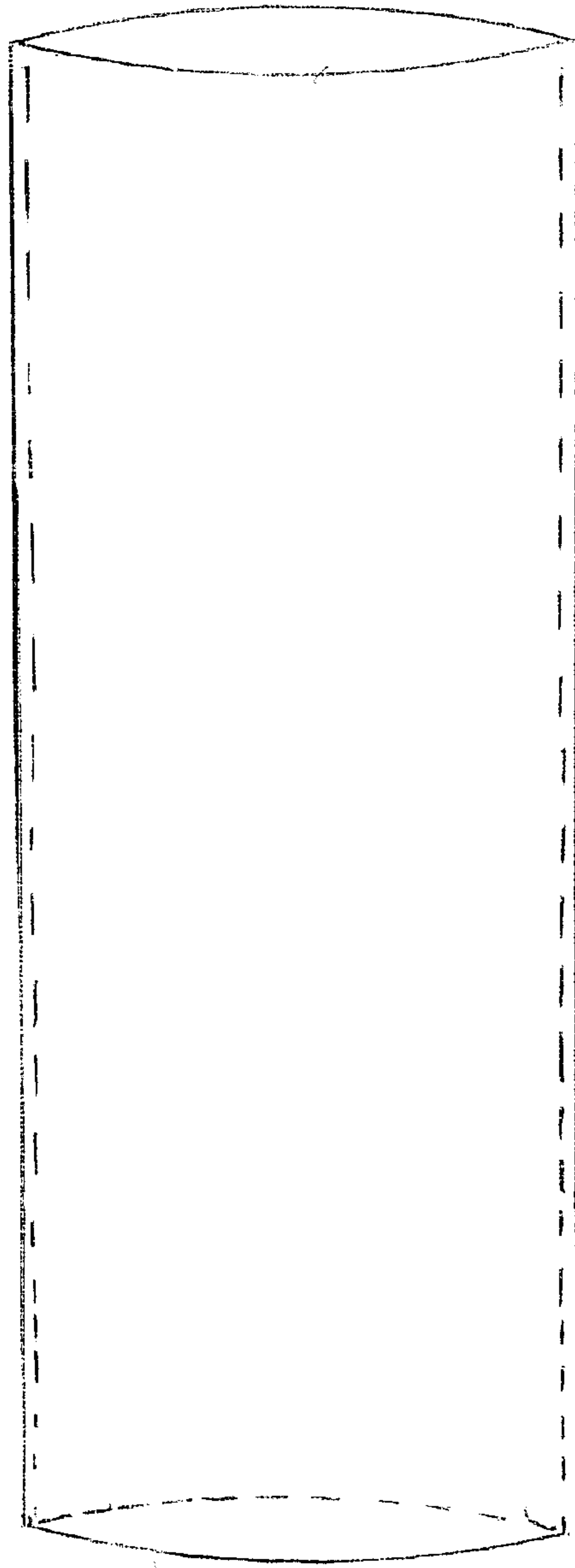

Fig. 6



30

Fig. 7

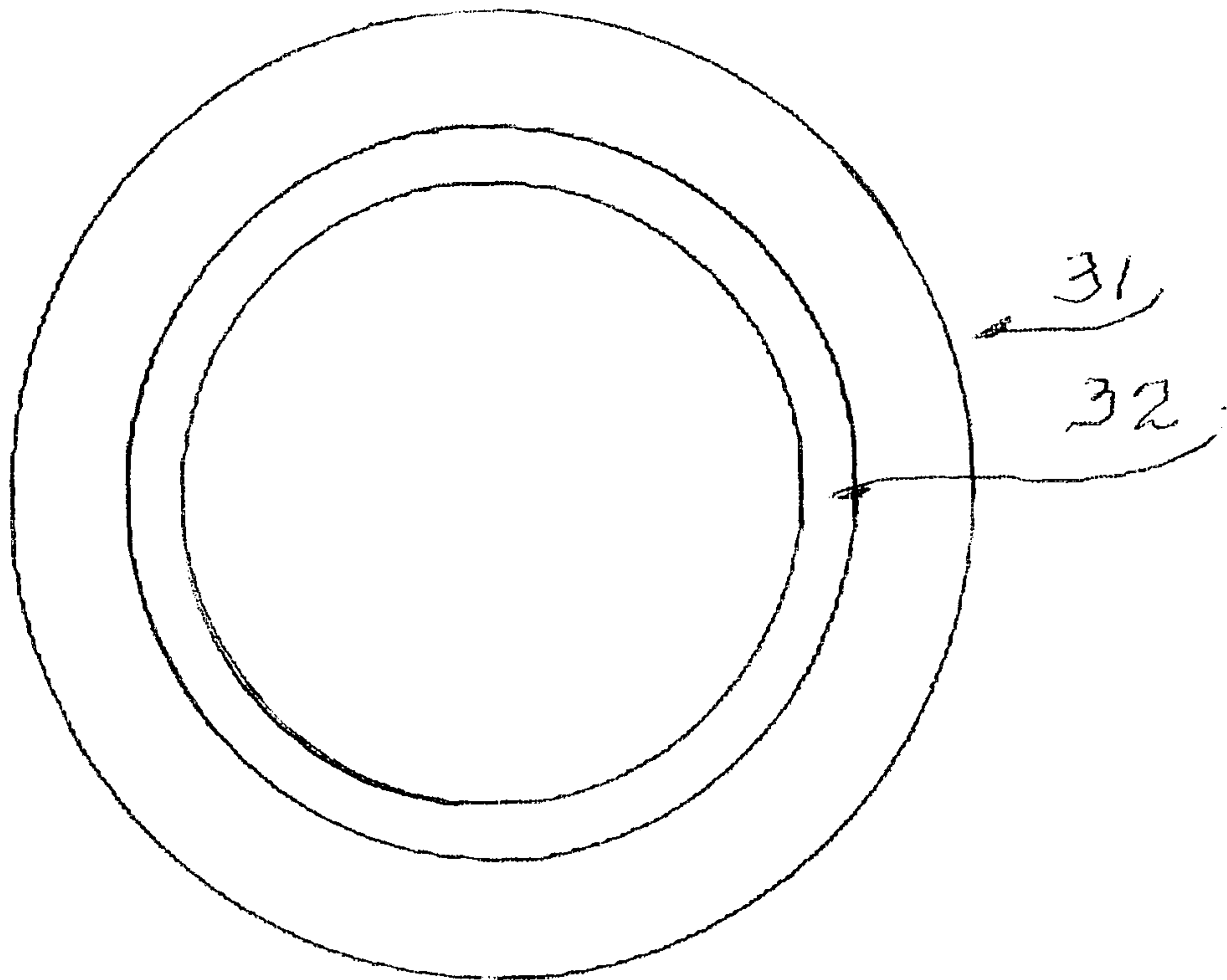
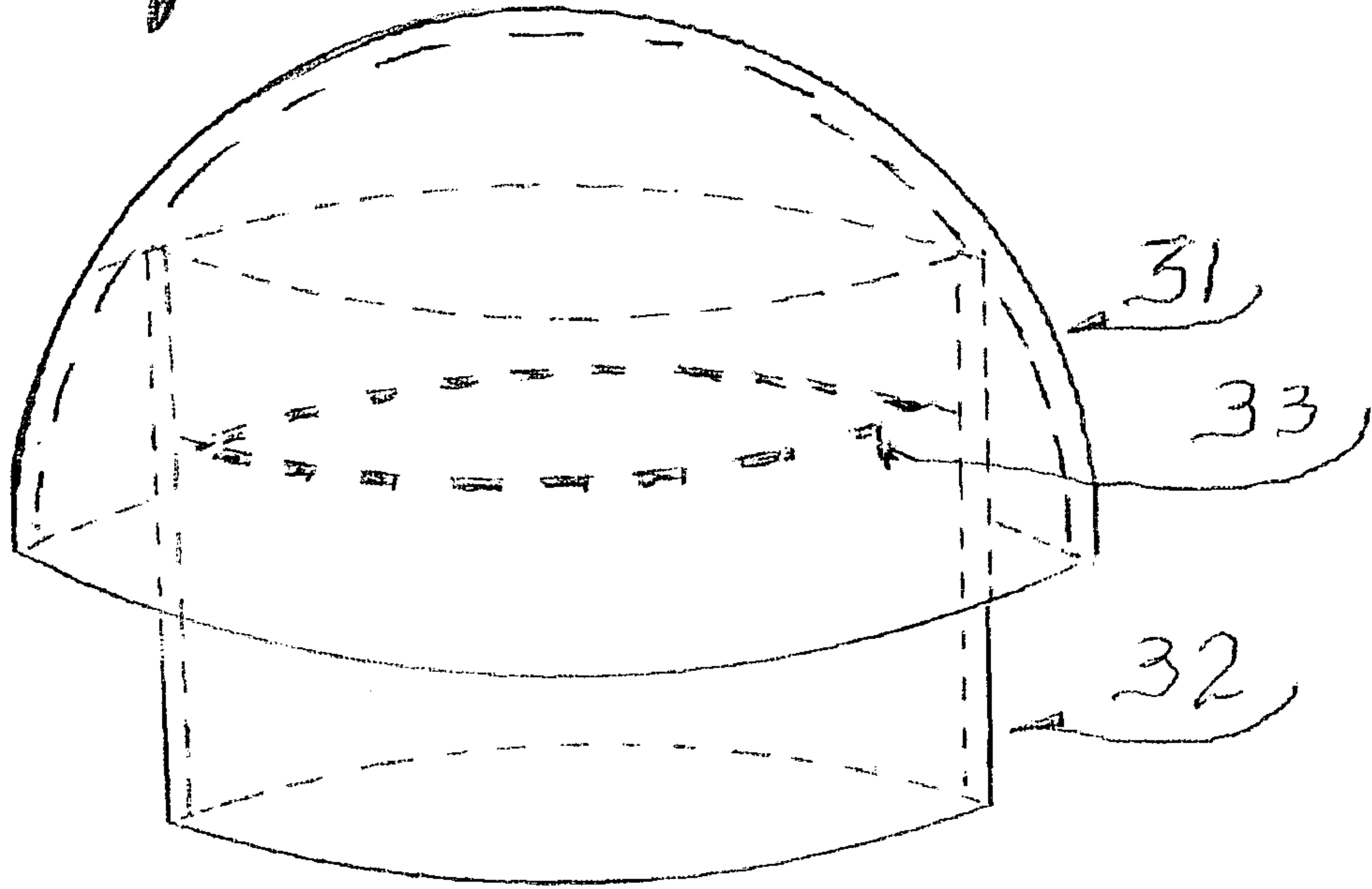

Fig. 8

