

W. HILL.
Clothes-Wringer.

No. 203,621.

Patented May 14, 1878.

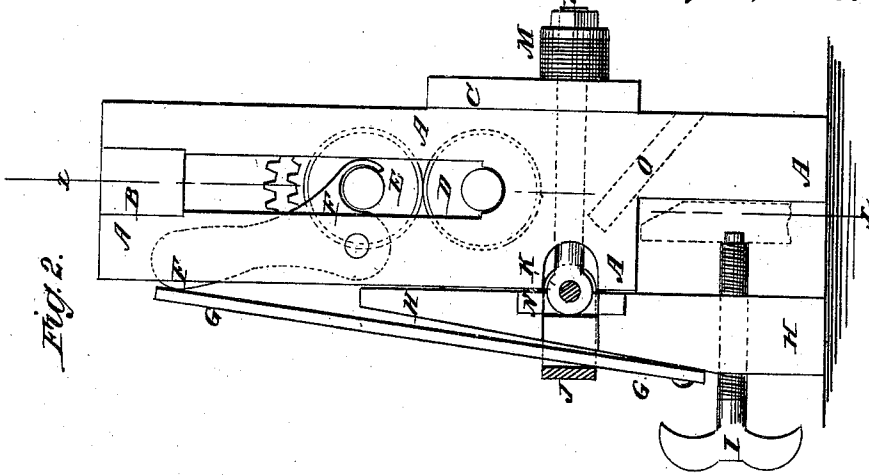

Fig. 2.

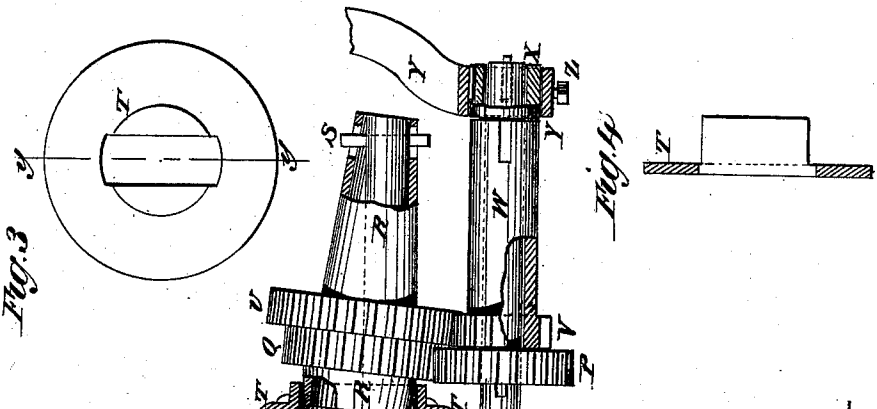

Fig. 3.

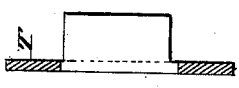

Fig. 4.

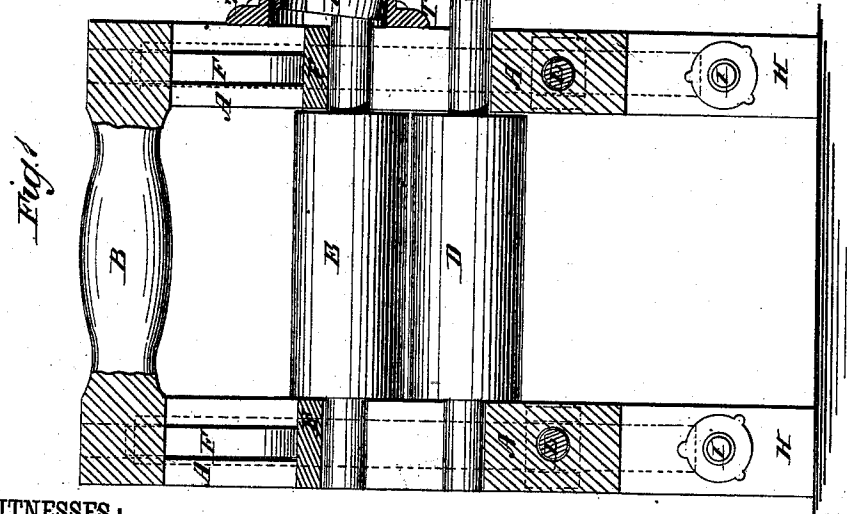

Fig. 1.

WITNESSES:

Francis McArdle.
Bedgwick

INVENTOR:

W. Hill
BY *Munn & Co*

ATTORNEYS.

UNITED STATES PATENT OFFICE.

WILLIAM HILL, OF SENNETT, NEW YORK.

IMPROVEMENT IN CLOTHES-WRINGERS.

Specification forming part of Letters Patent No. **203,621**, dated May 14, 1878; application filed December 7, 1877.

To all whom it may concern:

Be it known that I, WILLIAM HILL, of Sennett, in the county of Cayuga and State of New York, have invented a new and useful Improvement in Clothes-Wringers, of which the following is a specification:

Figure 1 is a side view of my improved wringer, partly in section, through the line *x x*, Fig. 2, and parts being broken away to show the construction. Fig. 2 is an end view of the same, partly in section, to show the construction. Fig. 3 is a detail plan view of a modified bearing for the cone hub. Fig. 4 is a cross-section of the same, taken through the line *y y*, Fig. 3.

Similar letters of reference indicate corresponding parts.

The object of this invention is to furnish clothes-wringers which shall be so constructed that the gear-wheels will remain in mesh however much the pressure-rollers may be forced apart, that they may be adjusted at the option of the operator to give an increased leverage, that the rollers will be pressed together only when the said wringers are attached to their supports, and which shall be simple in construction, inexpensive in manufacture, strong and durable, and effective in operation.

The invention will first be described in connection with the drawing, and then pointed out in the claims.

A are the standards or side bars of the wringer, which are connected at their upper ends by a cross-bar, B, which also serves as a handle.

The standards A are connected, a little below their centers, by the clothes-guard C, the ends of which are attached to the rear sides of the said standards. The lower ends of the standards A are rabbeted upon the rear sides to form a space to receive the edge of the tub or other support.

The upper parts of the standards A are slotted to receive the journals of the rubber rollers D E, the journals of the lower roller D resting in the lower ends of the said slots, and the upper roller E resting upon the lower one. In slots in the rear upper parts of the standards A are pivoted the bent levers F at their angles. The short arms of the levers

F project inward, are widened, and are concaved upon their lower sides to rest and fit upon the journals of the upper roller E. The long arms of the levers F project upward and outward, so that the upper ends of the spring-bars G may rest against their outer sides.

The lower ends of the spring-bars G are bolted to the lower part of the movable jaws H, which are provided with hand-screws I, to be turned forward against the side of the tub or other support to clamp the said support against the rabbeted lower ends of the standards A. The outer side of the upper part of the movable jaws H are beveled off, to allow the upper end of the spring-bars G to come in contact with the lever F.

The opposite sides of the middle parts of the movable jaws H are notched to receive the arms of the U bars or straps J, through the ends of which pass bolts K. The bolts K also pass through the tubular eyes of the eyebolts L, which pass through the standards A, and have washers and nuts placed upon their forward ends.

The inner side of the movable jaws H and the outer edges of the standards A are recessed to receive the eyes of the eyebolts L, so that the said eyebolts may have a longitudinal movement, and at the same time may serve as hinges or pivots to the movable jaws H.

M are rubber blocks placed upon the forward ends of the bolts L, between the washers of the said bolts and the standards A.

To the inner sides of the middle parts of the movable jaws H are attached the ends of the outer clothes-guard N, which also serves to keep the said movable jaws H in their proper relative positions.

To the inner sides of the lower parts of the standards A are attached the ends of an inclined board, O, to guide the water squeezed out of the clothes by the rollers D E back into the tub. By this construction there will be no pressure between the rollers D E until the wringer is secured to the side of the tub, by which operation the upper ends of the spring-bars G will be forced against the upper ends of the levers F, causing the lower ends of the said levers to force down the upper roller E, the elasticity of the bars G allowing the said

roller E to adjust itself to the varying thickness of the clothes being operated upon.

P is a gear-wheel, keyed or otherwise attached to the projecting journal of the lower roller D, and the teeth of which mesh into the teeth of a gear-wheel, Q, formed upon or attached to the larger or inner part of the conical hub R, placed upon the projecting journal of the upper roller E, and secured at its smaller or outer end to the outer end of the said journal by a pin, S, which passes through a hole in the end of the journal, and through an elongated hole or short slot in the end of the hub. This construction allows the journal of the roller E to work in the conical cavity of the hub R as the said roller moves up and down in adjusting itself to the varying thickness of the clothes without throwing the gear-wheels Q P out of gear. The inner end of the conical hub R revolves in the ring-flange of the plate T, attached to the outer side of the standard A, or formed upon it when the said standard is made of iron.

If desired, the bearing-flange for the inner end of the hub R may be placed within its cavity. In this case the plate T has a vertical slot formed in it, with outwardly-projecting flanges at the opposite sides of the said slot, the said flanges being curved upon their outer sides and straight upon their inner sides, as shown in Fig. 3.

To the hub R, at the outer side of the gear-wheel Q, is attached, or upon it is formed, a larger gear-wheel, U, the teeth of which mesh into the teeth of a smaller gear-wheel, V, placed at the outer side of the gear-wheel P, and formed upon or attached to the inner end of a sleeve, W, placed upon the journal of the lower roller D, and kept in place by a short tube, X, placed upon and keyed to the end of the said journal, and which is of the same diameter as the sleeve W, so that the outer surfaces of the said sleeve and tube may be flush with each other.

In the side of the tube X and the sleeve W is formed a groove to receive a tongue formed in the eye of the crank Y, so that the said crank may be adjusted upon the tube X or

sleeve W, as may be desired. The crank Y is secured in place when adjusted by a set-screw, Z. With this construction, when the crank Y is secured to the tube X it will revolve the lower roller, the upper roller being revolved by the gear-wheels P Q and the hub R. When the crank Y is secured to the sleeve W the upper roller will be revolved by the sleeve W, the gear-wheels V U, and the hub R, and the lower roller will be revolved from the hub R by the gear-wheels Q P. The latter arrangement enables the machine to be operated with an increased leverage, and is especially intended for use when wringing large articles.

Having thus described my invention, I claim as new and desire to secure by Letters Patent—

1. The combination of the conical hub R, the flanged bearing-plate T, and the gear-wheels Q P with the journals of the rollers D E and the standard A of a clothes-wringer, substantially as herein shown and described.

2. The combination of the sleeve W and the gear-wheels V U with the conical hub R, the flanged bearing-plate T, and the gear-wheels Q P, and with the roller-journals and standards of a clothes-wringer, substantially as herein shown and described.

3. The combination, with the gear-wheels P Q U V, conical hub R, and ring-flanged plate T, of the grooved sleeve W, the grooved tube X and the tongued crank Y, the latter adapted to transmit power either through the parts X P Q or the parts W V U, whereby the leverage of the crank or the relative rates of speed of rollers and crank may be changed, as desired, as and for the purpose specified.

4. The combination of the rubber springs M with the bolts and straps L K J, the movable jaws H, the bars G, whether elastic or rigid, the bent levers F, the journal of upper roll E, the hand-screws I, and the standards A, substantially as herein shown and described.

WILLIAM HILL.

Witnesses:

HENRY GLANVILLE,
CHARLES DRESSER.