

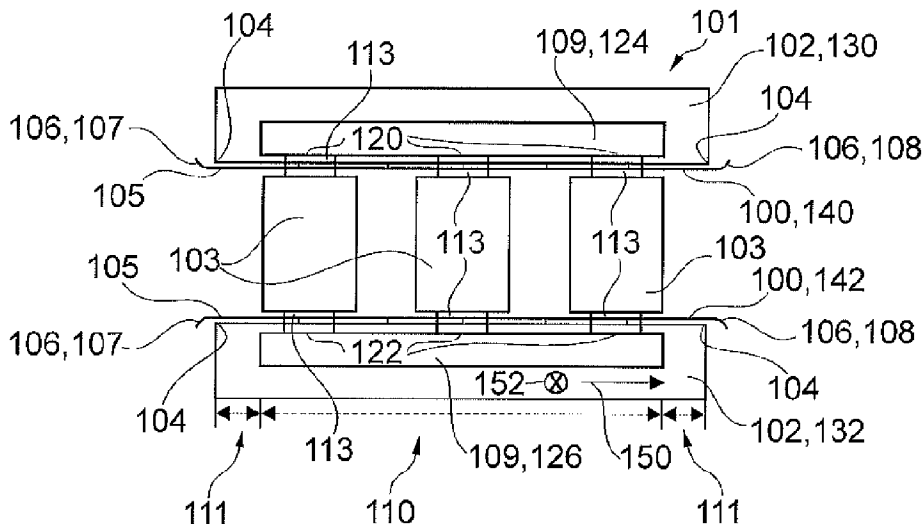

(86) Date de dépôt PCT/PCT Filing Date: 2011/06/21  
 (87) Date publication PCT/PCT Publication Date: 2012/01/05  
 (45) Date de délivrance/Issue Date: 2020/06/09  
 (85) Entrée phase nationale/National Entry: 2012/12/18  
 (86) N° demande PCT/PCT Application No.: EP 2011/060299  
 (87) N° publication PCT/PCT Publication No.: 2012/000828  
 (30) Priorité/Priority: 2010/06/28 (EP10167493.5)

(51) Cl.Int./Int.Cl. *H01F 27/36* (2006.01)  
 (72) Inventeurs/Inventors:  
 ROY, CARLOS, ES;  
 MURILLO, RAFAEL, ES;  
 TEPPER, JENS, DE;  
 SMAJIC, JASMIN, CH;  
 LETOSA FLETA, JESUS, ES;  
 USON, ANTONIO, ES;  
 VILLEN, MARIA TERESA, ES;  
 SAMPLON, MIGUEL, ES  
 (73) Propriétaire/Owner:  
 ABB SCHWEIZ AG, CH  
 (74) Agent: NORTON ROSE FULBRIGHT CANADA  
 LLP/S.E.N.C.R.L., S.R.L.

(54) Titre : TRANSFORMATEUR A PINCES BLINDEES  
 (54) Title: TRANSFORMER WITH SHIELDED CLAMPS



(57) **Abrégé/Abstract:**

The present invention relates to the shielding of clamps of a transformer, and in particular to an electric shielding arrangement for a transformer and a transformer with the arrangement. An electric shielding arrangement for a transformer (101) is provided, with a clamp (102, 130, 132) attached at a yoke (109, 124, 126) and stabilizes the yoke (109, 124, 126) of the transformer (101). The arrangement comprises an electric shielding device (100, 140, 142) arranged at the clamp (102, 130, 132) between the yoke (109, 124, 126) and a winding (103) of the transformer (101) and having a trough-like form. The electric shielding device (100, 140, 142) may have the form of a rounded cover and is adapted for shielding the clamp (102, 130, 132) from an electric field of the winding (103).

## (12) INTERNATIONAL APPLICATION PUBLISHED UNDER THE PATENT COOPERATION TREATY (PCT)

(19) World Intellectual Property Organization  
International Bureau(43) International Publication Date  
5 January 2012 (05.01.2012)

PCT

(10) International Publication Number  
**WO 2012/000828 A1**(51) International Patent Classification:  
*H01F 27/36* (2006.01)(21) International Application Number:  
PCT/EP2011/060299(22) International Filing Date:  
21 June 2011 (21.06.2011)

(25) Filing Language: English

(26) Publication Language: English

(30) Priority Data:  
10167493.5 28 June 2010 (28.06.2010) EP(71) Applicant (for all designated States except US): **ABB TECHNOLOGY AG** [CH/CH]; Affölnernstrasse 44, CH-8050 Zürich (CH).

(72) Inventors; and

(75) Inventors/Applicants (for US only): **ROY, Carlos** [ES/ES]; Santa Teresa de Jesus 9, E-50006 Zaragoza (ES). **MURILLO, Rafael** [ES/ES]; Madre Sacramento 53, 4A, E-50004 Zaragoza (ES). **TEPPER, Jens** [DE/DE]; Springstrasse 22, D-59929 Brilon (DE). **SMAJIC, Jasmin** [BA/CH]; Dorfwiesenstrasse 22, CH-8165 Schöfflisdorf (CH). **LETOSA FLETA, Jesus**; c/o Plablo Iglesias n°33, 8°B, E-50018 Zaragoza (ES). **USON, Antonio** [ES/ES]; Paseo de Sagasta 2m 3°izda., E-50006 Zaragoza (ES). **VILLÉN, María Teresa** [ES/ES]; c/o Viridiana, 11 3 izq., E-50019 Zaragoza (ES). **SAM-****PLON, Miguel** [ES/ES]; Paseo Teruel 19 5°, E-50004 Zaragoza (ES).(74) Agents: **INGOLD, Mathias** et al.; ABB Patent Attorneys, Zusammenschluss 154, c/o ABB Schweiz AG, Intellectual Property CH-LC/IP, Brown Boveri Strasse 6 CH-5400 Baden (CH).

(81) Designated States (unless otherwise indicated, for every kind of national protection available): AE, AG, AL, AM, AO, AT, AU, AZ, BA, BB, BG, BH, BR, BW, BY, BZ, CA, CH, CL, CN, CO, CR, CU, CZ, DE, DK, DM, DO, DZ, EC, EE, EG, ES, FI, GB, GD, GE, GH, GM, GT, HN, HR, HU, ID, IL, IN, IS, JP, KE, KG, KM, KN, KP, KR, KZ, LA, LC, LK, LR, LS, LT, LU, LY, MA, MD, ME, MG, MK, MN, MW, MX, MY, MZ, NA, NG, NI, NO, NZ, OM, PE, PG, PH, PL, PT, RO, RS, RU, SC, SD, SE, SG, SK, SL, SM, ST, SV, SY, TH, TJ, TM, TN, TR, TT, TZ, UA, UG, US, UZ, VC, VN, ZA, ZM, ZW.

(84) Designated States (unless otherwise indicated, for every kind of regional protection available): ARIPO (BW, GH, GM, KE, LR, LS, MW, MZ, NA, SD, SL, SZ, TZ, UG, ZM, ZW), Eurasian (AM, AZ, BY, KG, KZ, MD, RU, TJ, TM), European (AL, AT, BE, BG, CH, CY, CZ, DE, DK, EE, ES, FI, FR, GB, GR, HR, HU, IE, IS, IT, LT, LU, LV, MC, MK, MT, NL, NO, PL, PT, RO, RS, SE, SI, SK, SM, TR), OAPI (BF, BJ, CF, CG, CI, CM, GA, GN, GQ, GW, ML, MR, NE, SN, TD, TG).

[Continued on next page]

(54) Title: TRANSFORMER WITH SHIELDED CLAMPS

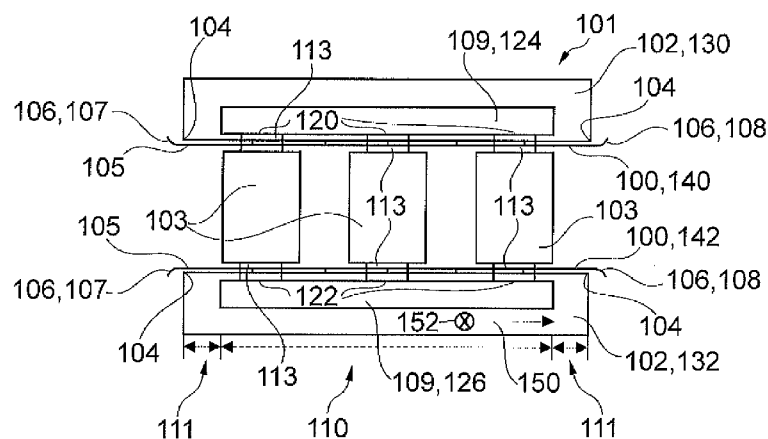

Fig. 1

(57) Abstract: The present invention relates to the shielding of clamps of a transformer, and in particular to an electric shielding arrangement for a transformer and a transformer with the arrangement. An electric shielding arrangement for a transformer (101) is provided, with a clamp (102, 130, 132) attached at a yoke (109, 124, 126) and stabilizes the yoke (109, 124, 126) of the transformer (101). The arrangement comprises an electric shielding device (100, 140, 142) arranged at the clamp (102, 130, 132) between the yoke (109, 124, 126) and a winding (103) of the transformer (101) and having a trough-like form. The electric shielding device (100, 140, 142) may have the form of a rounded cover and is adapted for shielding the clamp (102, 130, 132) from an electric field of the winding (103).



WO 2012/000828 A1

**WO 2012/000828 A1** 

---

**Published:**

— *with international search report (Art. 21(3))*

## DESCRIPTION

### TRANSFORMER WITH SHIELDED CLAMPS

5

#### FIELD OF THE INVENTION

The invention relates to the shielding of clamps of transformers. In particular, the invention relates to an electric shielding arrangement for a transformer and a transformer comprising the arrangement.

10

#### BACKGROUND OF THE INVENTION

Transformers may be widely used for low, medium, and high voltage applications.

15

Typically, in dry type transformers, the high voltage to clamp insulation is made by an airspace between the high voltage surrounded by solid insulation (e.g. casted) and the clamp surface being bare or insulated by some films. Support blocks for coils are also placed between the clamps and the coils. The clamps typically include tie rods, balls, nuts, and welded steel and comprise several sharp metallic edges.

20

Carbon steel clamps may be used in dry transformers. The clamps may have a U-profile or may have a form of a bended plate. In some cases the clamps show polished edges to avoid the sharp edges, leading to an equivalent radii of about 1-3 mm (for oil and dry transformers). The clamp side facing the windings may be bare or insulated by some films.

25

#### SUMMARY OF THE INVENTION

It may be seen as an object of the invention to increase the dielectric strength of a transformer.

30

According to one embodiment of the invention an electric shielding arrangement for a transformer is provided with a clamp attached at a yoke and stabilizing the yoke of the transformer, and an electric shielding device. The electric shielding device is arranged at the clamp between the yoke and a winding of the transformer. The electric  
5 shielding device is adapted for shielding the clamp from an electric field of the winding.

In other words, a cover may be placed on a clamp facing the winding, and the cover may act as an electrostatic shield or as a protective shield in order to shield the  
10 sharp edges of the clamp itself and all other metallic edges related to the clamp, so smoothing the electric field of the transformer with respect to the clamps. This shielding cover is kept bare, not covered by any insulation film. The shielding cover may be insulated according to another embodiment of the invention. The clamp is adapted for holding together or mechanically fixing or stabilizing a yoke of the  
15 transformer to the coil(s) of the transformer. The electric shielding device may cover the clamp and/or may have a vat- or trough-like form covering the clamp. The yoke is adapted for connecting at least two limbs. More than one yoke may be provided. The winding may be arranged around at least one of the at least two limbs.

20 The above mentioned electric shielding device arrangement is applicable to dry transformers with a voltage level above 70kV effectively shielding the clamp of the dry transformer from the electric field generated by the winding of the dry transformer. Thus a dry transformer with HV winding designed as HV disc winding with a voltage level of 70kV and above may be built as compact as a dry transformer  
25 with a lower voltage level. There may be higher field strength in the critical region between the HV winding and the clamp and particularly higher field peaks at the HV disc winding and the edges of the clamp compared to a dry transformer with a voltage level below 70 kV requiring a higher dielectric strength. This required higher dielectric strength may be provided by the electric shielding device which may  
30 homogenize the electric field to the ground such that the

clamp is prevented from overheating or losing its required mechanical strength due to discharges of the electric field to the edges of the clamp by the electric shielding device.

The electric shielding device may comprise a material selected from the group  
5 consisting of steel, and aluminium, and generally any conducting material with stabilizing mechanical properties.

The electric shielding device may increase the breakdown voltage and may lead to a  
25% improvement of shielding between winding of the transformer coil and the clamps  
10 compared to clamps without a electric shielding device according to impulse voltage tests.

The clamp may have rounded edges forming a rounded clamp that may have the  
function of the electric shielding device, shielding the clamp from an electric field  
generated by the winding or windings of the transformer. According to another  
15 embodiment of the invention the rounded clamp is provided without an electric shielding device.

According to another embodiment of the invention the electric shielding device  
comprises rounded edges. Such an electric shielding device with rounded edges may  
20 smooth an electric field of the winding of a transformer with respect to the transformer clamp by avoiding field peaks or discharges at edges of the clamp, thus preventing the clamp from overheating or losing its required mechanical strength.

According to another embodiment of the invention the form of the electric shielding  
25 device may be trough-like with rounded edges at the edges of the trough-like electric shielding device.

According to another embodiment of the invention the rounded edges of the  
arrangement comprise first rounded edges at a longitudinal side of the clamp facing the  
30 winding of the transformer. By providing first rounded edges at a longitudinal side of the clamp such that the first rounded edges are facing the winding of a transformer, the clamp may be effectively shielded from the electric field generated in the winding by essentially

avoiding electric field peaks that would possibly occur if the (sharp) edges of the electric shielding device at the longitudinal side of the clamp would be not rounded. Thus the mechanical strength of the clamp at its longitudinal side or at the side where the clamp is stabilizing the yoke of the transformer may be ensured and not be lost by overheating the clamp due to discharges from the electric field to (sharp) edges of the electric shielding device.

According to another embodiment of the invention the rounded edges of the arrangement further comprise second round edges at a first end and at a second end of the electric shielding device at a transverse side of the clamp. The second rounded edges at the first and second end of the electric shielding device at a transverse side of the clamp provides effective shielding of the clamp against an electric field of the winding at the most critical areas of the clamp concerning possible discharges due to the electric field. As described above electrical field peaks may be avoided by the second rounded edges that would possibly occur if the (sharp) edges of the electric shielding device at the transversal sides of the clamp would be not rounded. Thus an overheating and losing of the mechanical stability of the clamp at its transversal side due to discharges from the electrical field to (sharp) edges of the electric shielding device may be prevented

According to another embodiment of the invention the first or second rounded edges have a radius of 5-45 mm, in particular 30 mm. By providing first or second rounded edges of a radius of 5 to 45 mm the shielding properties of the electric shielding device are improved compared to first or second rounded edges of a different radius or a radius of 0 mm. Particularly a radius of 30 mm for the first and/or second rounded edges provides for an effective shielding of the electric field of the winding to the clamp due to the avoidance of field peaks at possible edges of the electric shielding device and/or the clamp and an effective smoothing of the electric field.

According to another embodiment of the invention the first rounded edges have a different radius at a first region at a yoke of the transformer and at a second region that is not at the yoke. Thus at a first region at a yoke of the transformer depending on the core stacking a smaller radius, particularly a radius of 10 mm, may be provided, and at a second region that is not at the yoke a larger radius, particularly a radius of 30 mm, may be

provided ensuring a sufficient optimal shielding of the electric field of the winding to the clamp while enabling an easy mounting of the electric shielding device particularly in the first region at the yoke, where larger radii could lead to a difficult mounting of the electric shielding device, and a saving of material.

5

According to another embodiment of the invention the electric shielding device is grounded by being connected to the clamp. Such a grounding of the shielding device by connecting the shielding device to the clamp may provide for the clamp being free of an electric field. The electric shielding device is affected by the electric field of the winding and not the clamp.

10

The connection of the electric shielding device to the clamp may be a screw-thread connection, for example the electric shielding device may have threaded pins or threaded holes matching with holes in the clamp, such that the electric shielding device may be screwed to the clamp.

15

According to another embodiment of the invention the electric shielding device is welded to the clamp. By welding the electric shielding device to the clamp an efficient and easy mounting of the electric shielding device to the clamp may be provided as no holes for screw connections may be necessary to fix the electric shielding device to the clamp. Furthermore an electric shielding device with no recesses or through-holes for fastening the electric shielding device may be provided allowing for better shielding properties as through-holes and recesses may have sharp edges which may cause or abet discharges from the electric field of the winding to the electric shielding device. Thus a cheaper electric shielding device may be provided as no possible sharp edges of recesses or through-holes have to be rounded.

20

25

According to another embodiment of the invention the first rounded edges have a length of  $1/8$  of the circumference of a corresponding sphere defined by the radius of the first rounded edges or in other words the first rounded edges may have a length of  $1/8$  of a sphere. Such first rounded edges with a length of  $1/8$  of a sphere may provide for an efficient electric shielding device, for an easy and cheap manufacturing of the electric

30

shielding device and mounting to the clamp, and may enable manufacturing a compact, room saving transformer.

5 According to another embodiment of the invention the arrangement further comprises holes for placing support block inserts and pressing bolts of the transformer. The holes may be recesses receiving matching counterparts such as the above mentioned pressing bolts. By providing holes for placing support block inserts and pressing bolts of the transformer in the electric shielding device an easier, more efficient manufacturing of the electric shielding device and an easier, more efficient mounting of the electric shielding  
10 device to the clamp may be achieved as no additional holes for mounting the electric shielding device to the clamp are needed, for example. Such additional holes may affect, and particularly decrease the shielding function of the electric shielding device due to possible sharp edges at the holes, for example.

15 According to another embodiment of the invention the electric shielding device projects over edges of the clamp. Thus the electric shielding device may be adapted for shielding the clamp from an electric field generated in the winding of the transformer

20 According to another embodiment of the invention a transformer is provided, the transformer comprising the arrangement of one of the above-mentioned embodiments, at least two limbs, a winding arranged around at least one of the at least two limbs, and a first yoke connecting the at least two limbs. Such transformer with an electric shielding arrangement may effectively shield the clamp of a transformer from the electric field generated by the winding of the transformer. Thus for example a dry transformer with HV  
25 winding designed as HV disc winding with a voltage level of 70kV and above may be built as compact as a dry transformer with a lower voltage level. There may be higher field strength in the critical region between the HV winding and the clamp and particularly higher field peaks at the HV disc winding and the edges of the clamp compared to a dry transformer with a voltage level below 70 kV requiring a higher dielectric strength. This  
30 required higher dielectric strength may be provided by the electric shielding device which may homogenize the electric field to the ground such that the clamp is prevented from overheating or losing its required mechanical strength due to discharges of the electric field to the edges of the clamp by the electric shielding device. The following embodiments may

all have the above mentioned advantages compared to a transformer without the above and below mentioned electric shielding arrangement.

5 According to another embodiment of the invention the transformer is a dry type transformer.

According to another embodiment of the invention the transformer is a dry distribution transformer.

10 According to another embodiment of the invention the transformer is applicable at a 72.5 kV voltage level.

According to another embodiment of the invention the transformer is applicable at a level above a 72.5 kV voltage level.

15

According to another embodiment of the invention the transformer is applicable at a level below a 72.5 kV voltage level.

20 According to another embodiment of the invention the electric shielding device of the transformer is arranged on all clamps of the transformer.

In other words, the transformer may comprise two clamps at the bottom and two clamps at the top, wherein an electric shielding device is arranged at each of the four clamps.

25 According to another embodiment of the invention the transformer is adapted for electrically shielding high voltage windings to the clamp of the transformer.

30 According to another embodiment of the invention the transformer is adapted for electrically shielding high voltage and low voltage windings to the clamp of the transformer.

According to another embodiment of the invention the transformer is adapted for electrically shielding low voltage windings to the clamp of the transformer.

5 According to another embodiment of the invention the electric shielding device of the transformer is adapted to electrically shield high voltage windings to the clamp of the transformer.

10 According to another embodiment of the invention the electric shielding device of the transformer is adapted to electrically shield high voltage and low voltage windings to the clamp of the transformer.

15 According to another embodiment of the invention the electric shielding device of the transformer is adapted to electrically shield low voltage windings to the clamp of the transformer.

20 According to another embodiment of the invention the transformer comprises three limbs each comprising a first limb end and a second limb end. The first yoke connects the three limbs at the first limb ends. The transformer further comprises a second yoke, that connects the three limbs at the second limb ends. The electric shielding arrangement of the transformer comprises first clamps attached at the first yoke to stabilize the first yoke, second clamps attached at the second yoke to stabilize the second yoke, first electric shielding devices arranged at the first clamps between the first yoke and three windings each of the windings arranged around each of the three limbs, and second electric shielding devices arranged at the second clamps between the second yoke and the three windings.

25

According to another embodiment of the invention the above-mentioned windings may be high voltage windings or low voltage windings.

30 These and other aspects of the present invention will become apparent from and elucidated with reference to the embodiments described hereinafter.

## BRIEF DESCRIPTION OF THE DRAWINGS

The subject-matter of the invention will be explained in more detail in the following text with reference to exemplary embodiments which are illustrated in the attached drawings.

5

Fig. 1 schematically shows a cross-sectional view of a transformer with an electric shielding arrangement according to one embodiment of the invention.

Fig. 2 schematically shows an electric shielding arrangement according to another  
10 embodiment of the invention.

Fig. 3 schematically shows a perspective view of the bottom of a transformer with an electric shielding arrangement according to another embodiment of the invention.

15 Fig. 4 schematically shows a perspective view of the top of the transformer of Fig. 3.

The reference signs used in the drawings, and their meanings, are listed in summary form in a list of reference symbols. In principle, identical parts are provided with the same reference symbols in the figures.

20

## DETAILED DESCRIPTION OF EXEMPLARY EMBODIMENTS

Fig. 1 schematically shows a cross-sectional view of an electric shielding arrangement for a transformer 101 comprising a clamp 102, 130, 132 attached at a yoke 109, 124, 126, and stabilizing the yoke 109, 124, 126 of the transformer 101, and an electric shielding device 100, 140, 142 arranged at the clamp 102, 130, 132 between the yoke 109, 124, 126 and a winding 103 of the transformer 101. The electric shielding device 100, 140, 142 is adapted for shielding the clamp 102, 130, 132 from an electric field of the winding 103. The clamp 102, 130, 132 is adapted for holding together or mechanically fixing the yoke  
30 109, 124, 126 of the transformer 101. The yoke 109, 124, 126 connects at least two limbs

113 of the transformer 101. The electric shield 100, 140, 142 may comprise rounded edges 105, 106.

The electric shielding device 100, 140, 142 may project over the edges 104 of the clamp 102, 130, 132.

5 The transformer 101 comprises the above mentioned arrangement and at least two limbs 113, in particular three limbs 113, each comprising a first limb end 120 and a second limb end 122. A winding 103 is arranged around at least one of the at least two limbs 113, in particular a winding 103 is arranged at three limbs 113. A first yoke 109, 124 connects the three limbs 113 at the first limb ends 120. A second yoke 109, 126 connects the three limbs  
10 113 at the second limb ends 122. The electric shielding arrangement comprises first clamps 102, 130 attached at the first yoke 109, 124 to stabilize the first yoke 109, 124, and second clamps 102, 132 attached at the second yoke 109, 124 to stabilize the second yoke 109, 126. First electric shielding devices 100, 140 are arranged at the first clamps 102, 130 between the first yoke 109, 126 and three windings 103 each of the windings 103 arranged  
15 around each of the three limbs 113. Second electric shielding devices 100, 142 are arranged at the second clamps 102, 132 between the second yoke 109, 126 and the three windings 103.

First rounded edges 105 are arranged at a longitudinal side 150 of the clamp 102, 130,  
20 132 facing the windings 103 of the transformer 101, wherein the windings 103 may be high voltage or low voltage windings. The longitudinal side 150 may be horizontal, and parallel to the yoke 109, 124, 126 limb 113 connecting side and perpendicular to the limbs 113 as indicated in Fig. 1. The first rounded edges 105 may arranged at edges 104 of the clamp 102, 130, 132 which may be metallic edges 104 related to the clamp 102, 130, 132.

25

The electric shielding device 100, 140, 142 may act as electrostatic shield to shield the sharp edges 104 of the clamp 102, 130, 132 itself and all other metallic edges 104 related to the clamp 102, 130, 132, thus smoothing the electric field of the transformer 101.

30 Second rounded edges 106 of the arrangement are arranged at the first end 107 and at the second end 108 of the electric shielding device 100, 140, 142 at a transverse side 152 of the clamp 102, 130, 132. The transverse side 152 may be horizontal, perpendicular to the longitudinal side 150 and to a vertical side parallel to the limbs 113.

The first or second rounded edges 105, 106 may have a radius of 10-45 mm, in particular 30 mm.

5 The first rounded edges 105 have a different radius at a first region 110 at a yoke 109, 109, 124, 126 of the transformer 101 then at a second region 111 that is not at the yoke 109, 124, 126. The electric shielding device 100, 140, 142 may be grounded by being connected to the clamp 102, 130, 132, for example by being welded to the clamp 102.

10 The first rounded edges 105 may have a length of 1/8 of a circumference of a sphere defined by the radius of the first rounded edges 105 or in other words the first rounded edges 105 may have a length of 1/8 of a sphere.

The transformer 101 may be a dry type transformer 101.

15

The electric shielding device 100, 140, 142 is arranged on all clamps 102 of the transformer 101, wherein the transformer 101 is adapted for electrically shielding the windings 103 which may be high voltage windings 103 or low voltage windings 103, or both, to the clamp 102, 130, 132.

20

The transformer 101 is applicable at a 72.5 kV level but may also be applicable at a level below or above 72.5 kV.

25 Fig. 2 schematically shows a cross-sectional view of an electric shielding arrangement with a clamp 102 and an electric shielding device 100. The electric shielding device 100 comprises rounded edges 105 which face a winding 103 of the transformer 101, wherein the clamp 102 is attached to a yoke 109 of the transformer 101. The electric shielding device 100 is adapted for shielding the clamp 102 from an electric field of the winding 103. The clamp 102 is adapted for holding together or mechanically fixing or stabilizing a  
30 yoke 109 of the transformer 101.

The yoke 109 of a transformer is arranged at the clamp 102. The electric shielding device 100 may have the same function as the electric shielding device 100 of Fig. 1. First rounded edges 105 at edges of clamp 102 between the yoke 109 and the clamp 102 may be provided, having a radius of  $R10 = 10$  mm facing the yoke 109, respectively at the yoke  
5 region of the transformer.

Second rounded edges 106 are arranged at a first end 107 of the electric shielding device 100 and have a radius of  $R30 = 30$  mm.

10 The arrangement of Fig. 2 further comprises holes 201 for placing support block inserts 202 and pressing bolts 204 of the transformer inside the holes, thereby fastening the support block 203 and the electric shielding device 100 to the clamp 102.

Fig. 3 schematically shows a perspective view of a bottom part of a transformer with a  
15 part of the clamp and shielding arrangement of Fig. 1. Windings 103, clamps 102 and the yoke 109 of a transformer are depicted.

Isolators 301 are arranged between the windings and the electric shielding devices 100 on top of the clamps 102.

20

The electric shielding devices 100 comprise rounded edges 105 which face the windings 103 of the transformer 101 with a clamp 102 being attached to the transformer 101. First rounded edges 105 at edges of the clamp 102 face the windings 103 of the transformer and may have a radius of 10-45 mm.

25

Second rounded edges 106 at a first end 107 of the electric shielding device 100 are provided and may have a radius of about 30 mm.

Fig. 4 schematically shows a top part of the transformer of Fig. 3 with two isolators 301  
30 isolating the windings 103 from the clamps 102 with the rounded electric shielding devices 100.

While the invention has been illustrated and described in detail in the drawings and the foregoing description, such illustration and description are to be considered illustrative or exemplary and not restricted; the invention is not limited to the disclosed embodiments.

5

Other variations of the disclosed embodiments may be understood and affected by those skilled in the art and practising the claimed invention, from a study of the drawings, the disclosure, and the appended claims.

10 In the claims, the word “comprising” does not exclude other elements or steps, and the indefinite article “a” or “an” does not exclude a plurality. A single electric shielding arrangement, or a single transformer and a single clamp or a single electric shielding device may fulfil the function of several items recited in the claims. The mere fact that  
15 certain measures are recited in mutually different dependent claims does not indicate that a combination of these measures may not be used to advantage. Any reference signs in the claims should not be construed as limiting the scope.

## LIST OF REFERENCE SIGNS

	100	Electric shielding device
	101	Transformer, dry transformer
	102	Clamp(s)
5	103	Winding, high voltage winding, coil(s)
	104	Edge(s), metallic edge(s)
	105	Rounded edges, first rounded edges
	106	Rounded edges, second rounded edges
	107	First end (of the electric shielding device)
10	108	Second end (of the electric shielding device)
	109	Yoke(s)
	110	First region (at the yoke)
	111	Second region (that is not at the yoke)
	120	First limb end(s)
15	122	Second limb end(s)
	124	First yoke
	126	Second yoke
	130	First clamp(s)
	132	Second clamp(s)
20	140	First electric shielding device(s)
	142	Second electric shielding device(s)
	150	Longitudinal side (of the clamp)
	152	Transverse side (of the clamp)
	113	Limb(s)
25	201	Holes
	202	Block inserts
	203	Support block
	204	Pressing bolts
	301	Isolator, isolators
30	R10	Radius of 10 mm
	R30	Radius of 30 mm

**PATENT CLAIMS**

1. An electric shielding arrangement for a transformer (101), the arrangement comprising:  
a clamp (102, 130, 132) attached at a yoke (109, 124, 126) and stabilizes the yoke (109,  
5 124, 126) of the transformer (101); and  
an electric shielding device (100, 140, 142) arranged at the clamp (102, 130, 132)  
between the yoke (109, 124, 126) and a winding (103) of the transformer (101);  
wherein the electric shielding device (100, 140, 142) is adapted for shielding the clamp  
(102, 130, 132) from an electric field of the winding (103); and  
10 wherein the electric shielding device (100, 140, 142) is welded to the clamp (102, 130,  
132).
2. The arrangement of claim 1,  
wherein the electric shielding device (100, 140, 142) comprises rounded edges (105,  
15 106).
3. The arrangement of claim 2, wherein the rounded edges (105, 106) comprise:  
first rounded edges (105) at a longitudinal side (150) of the clamp (102, 130, 132)  
facing the winding (103) of the transformer (101).  
20
4. The arrangement of claim 3, wherein the rounded edges (105, 106) further comprise:  
second rounded edges (106) at a first end (107) and at a second end (108) of the  
electric shielding device (100, 140, 142) at a transverse side (152) of the clamp (102,  
130, 132).  
25
5. The arrangement of claim 4:

wherein the first or second rounded edges (105, 106) have a radius in the range of 5 to 45 mm.

6. The arrangement of claim 5:

5 wherein the radius of the first or second rounded edges (105, 106) is 30 mm.

7. The arrangement of any one of claims 3 to 6,

wherein the first rounded edges (105) have a different radius at a first region (110) at the yoke (109, 124, 126) of the transformer (101) than at a second region (111) that is  
10 not at the yoke (109, 124, 126).

8. The arrangement of any one of claims 1 to 7,

wherein the electric shielding device (100, 140, 142) is grounded by being connected to the clamp (102, 130, 132).

15

9. The arrangement of any one of the claims 3 to 7,

wherein the first rounded edges (105) have  $1/8$  of a circumference of a corresponding sphere defined by the radius of the first rounded edges (105).

20 10. The arrangement of any one of claims 1 to 9, further comprising:

holes (201) for placing support block inserts (202) and pressing bolts (204) of the transformer (101).

11. The arrangement of any one of claims 1 to 10,

25 wherein the electric shielding device (100, 140, 142) projects over edges (104) of the clamp (102, 130, 132).

12. The arrangement of any one of claims 1 to 11, wherein the electric shielding device (100, 140, 142) has a vat or trough form covering the clamp (102, 130, 132).
13. Transformer (101) comprising:
- 5        an arrangement of any one of claims 1 to 12; and  
       at least two limbs (113);  
       the winding (103) arranged around at least one of the at least two limbs (113);  
       and a first yoke (109, 124) connecting the at least two limbs (113).
- 10    14. The transformer (101) of claim 13,  
       wherein the transformer (101) is a dry type transformer (101) applicable at a 72,5 kV  
       voltage level.
- 15    15. The transformer (101) of claim 13 or 14,  
       wherein the transformer (101) is adapted for electrically shielding high voltage  
       windings (103) to the clamp (102).
16. The transformer (101) of any one of claims 13 to 15, comprising:
- 20        three limbs (113) each comprising a first limb end (120) and a second limb end (122);  
       wherein the first yoke (109, 124) connects the three limbs (113) at the first limb ends  
       (120);  
       a second yoke (109, 126) connects the three limbs (113) at the second limb ends (122);  
       and  
       wherein the electric shielding arrangement comprises:
- 25        first clamps (102, 130) attached at the first yoke (109, 124) to stabilize the first yoke  
       (109, 124);

second clamps (102, 132) attached at the second yoke (109, 124) to stabilize the second yoke (109, 126);

5 first electric shielding devices (100, 140) arranged at the first clamps (102, 130) between the first yoke (109, 124) and three windings (103) each of the windings (103) arranged around each of the three limbs (113);

second electric shielding devices (100, 142) arranged at the second clamps (102, 132) between the second yoke (109, 126) and the three windings (103).

1/1

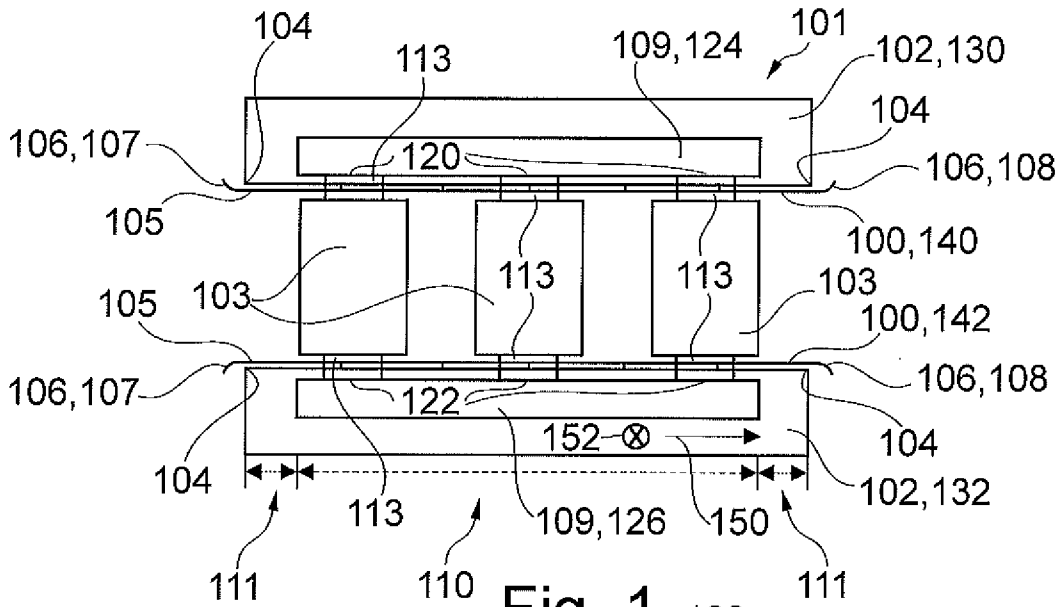

Fig. 1

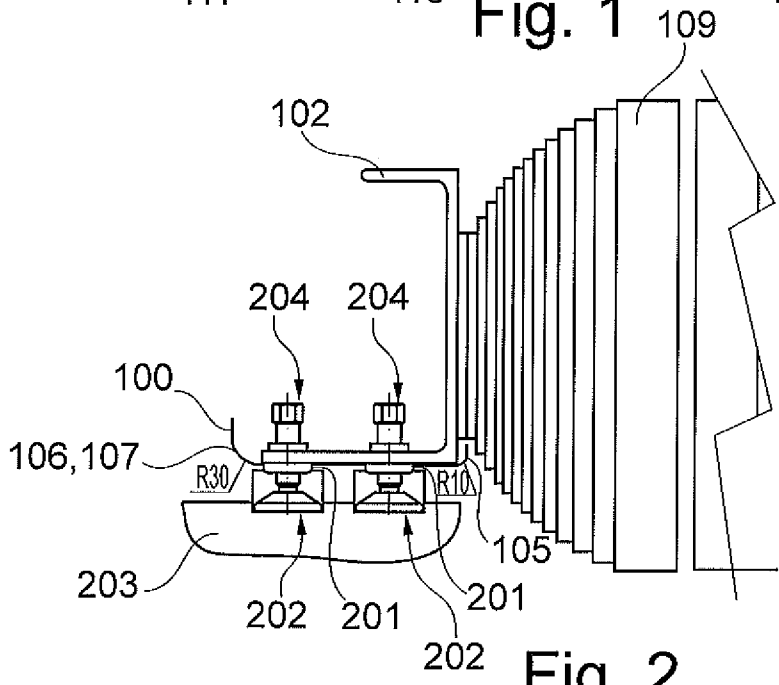

Fig. 2

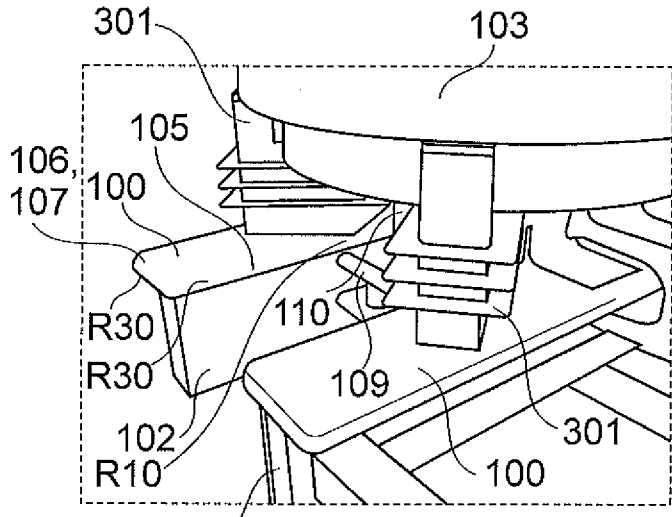

Fig. 3

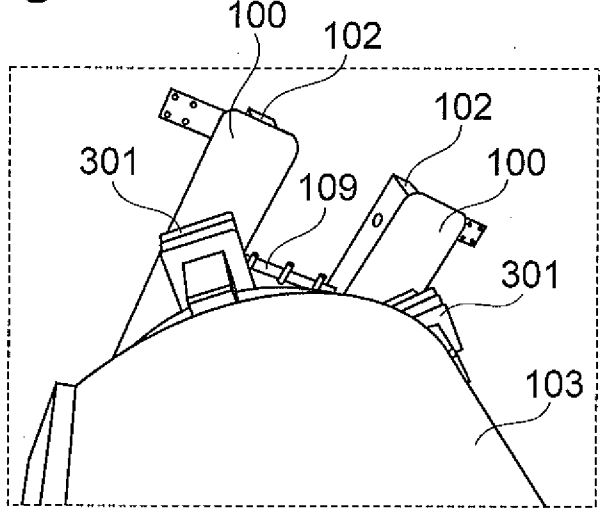

Fig. 4

