

Feb. 5, 1924.

1,482,437

C. KOEGEL ET AL
ROTARY SLITTING CUTTER

Filed March 8, 1922

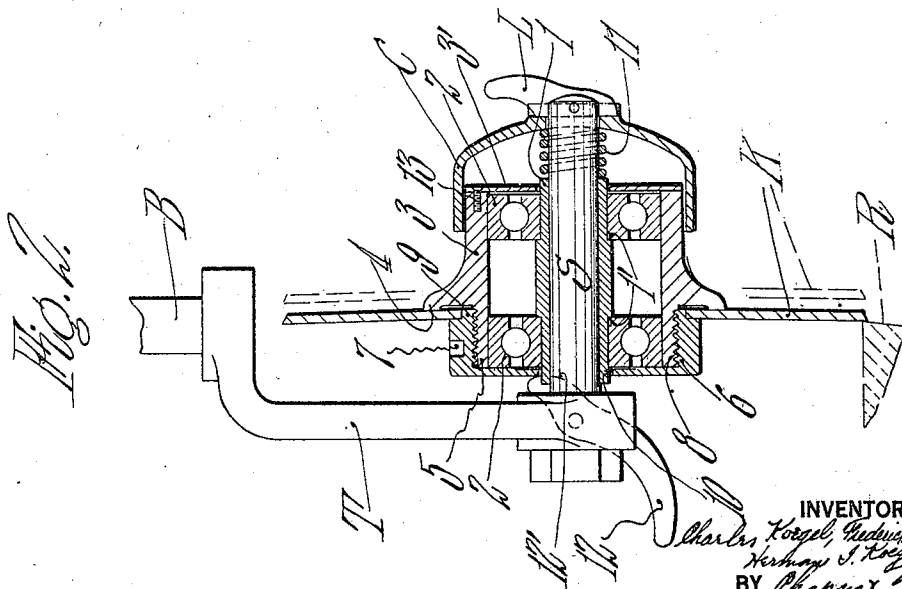
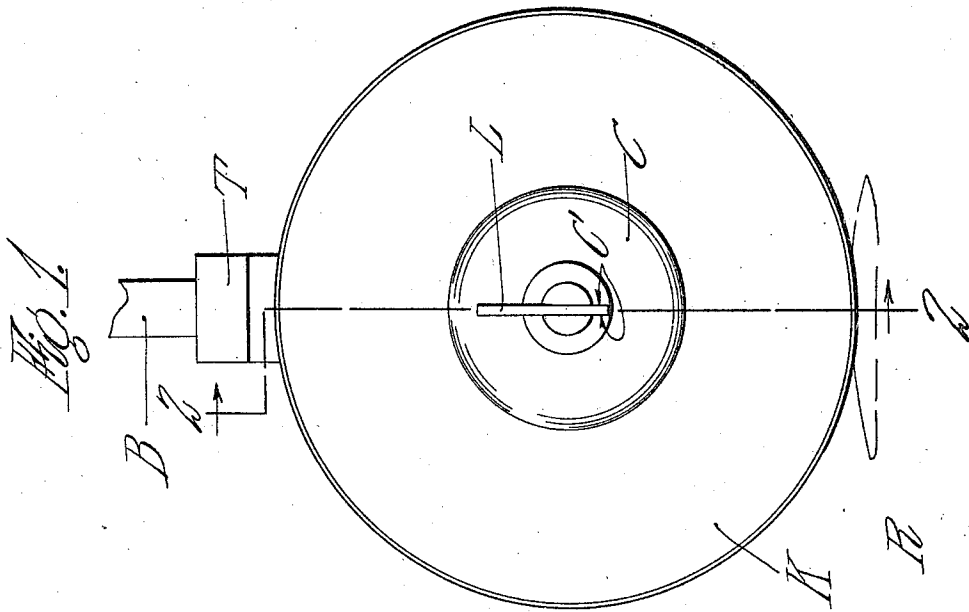

INVENTOR
Charles Koegel, Gustav W. Koegel
Herman J. Koegel
BY Chapman & Neal
ATTORNEYS

UNITED STATES PATENT OFFICE.

CHARLES KOEGEL, FREDERICK W. KOEGEL, AND HERMAN I. KOEGEL, OF HOLYOKE,
MASSACHUSETTS.

ROTARY SLITTING CUTTER.

Application filed March 8, 1922. Serial No. 541,980.

To all whom it may concern:

Be it known that we, CHARLES KOEGEL, FREDERICK W. KOEGEL, and HERMAN I. KOEGEL, citizens of the United States, residing at Holyoke, in the county of Hampden and State of Massachusetts, have invented new and useful Improvements in Rotary Slitting Cutters, of which the following is a specification.

This invention relates to improvements in rotary slitting cutters for paper machines or the like and is directed particularly to improvements in slitting cutters of the type disclosed in Patent #852,964 issued to me May 7, 1907.

Cutters of this general type are particularly adapted and arranged for use in connection with paper making machines when it is desired to cut or slit, the web of paper, being run on such machines. It is usual to so locate the slitting cutter upon the machine that the rotatable knife thereof cooperates with and is frictionally engaged and driven by a rotating cutting roll, slitting knife or other rotating element of the paper making machine.

In the patent above referred to, the rotatable slitting cutter is resiliently held in frictional engagement with the rotating cutter or slitter of the paper making machine by means of a coil spring that is interposed between a stationary member and the rotating slitting cutter hub. This spring tends to urge the cutter into frictional engagement with the driving cutter of the paper making machine for the slitting or cutting operation. But as the spring is thus interposed between stationary and rotating parts it is obvious that considerable friction results, which causes the speed of the revolving cutter to be retarded and also causes excessive wear of the parts.

One object of the present invention is the provision of means, for urging the rotatable cutter toward the driving element, that does not contract with the rotating cutter, whereby the said cutter is not retarded in its rotative movement and may accordingly rotate, at a speed corresponding to that of its driving element.

Another object of the invention is the provision of means between the rotatable cutter and its support that is adapted to permit at all times a freely rotative movement of the said cutter.

A further object is the provision of a device that is readily applicable to the present standard cutter supports now in use.

Other objects and advantages will appear from the following description and accompanying drawings in which the present preferred form of the invention is shown.

Fig. 1 is a side elevational view of a slitting cutter embodying my invention;

Fig. 2 is a sectional view on the line 2—2 of Fig. 1.

In the drawings B represents a hanger of the standard type that is adapted to be supported by the usual clamp (not shown) of a paper making machine. R represents a portion of a rotating cutter of a paper machine with which my slitting cutter is adapted to frictionally engage for the slitting operation and by means of which engagement the slitting cutter K is driven or rotated. The post B is usually held or supported by the clamp or other parts of the paper making machine in such a manner that the slitting cutter K may be lowered or raised accordingly as it is desired to vary the overlapping of the rotating driving element R and cutter K. A bracket T fixed to the post B carries a support S in the form of a stud that may be secured thereto in any suitable manner which support carries on its outer end a latch L that is pivoted thereto for a swinging movement as in the Patent 852,964 previously referred to.

For the proper operation of the device it is usual and customary that the axis of the cutter K be disposed at a slight angle with respect to the axis of the rotating cutter R and this may be accomplished by so shaping the bracket T or securing the support S thereto in such a manner that the axis of the support S is at a slight angular relation with respect to the axis of rotation of the roll R.

A hollow supporting tube or sleeve 1 for supporting the rotatable cutter is loosely mounted upon the support S and is adapted for a sliding and rotative movement thereon. Shoulders 1' are provided upon the sleeve as shown to position or space apart ball or roller bearings 2. Under certain conditions it may be desirable to provide a means whereby the sleeve may be held from a rotative movement upon the support without preventing a sliding movement therealong and obviously could be ac-

complished by the provision of an inter-fitting key and slot between the said sleeve and support.

A hollow cutter hub 3 is provided that carries a circular flange 4 which serves as an abutment flange against which the disk cutter K is clamped. A male screw-threaded portion 5 extends forwardly of the flange and is adapted to receive a clamping nut 6. An end plate 3' having a central opening for encircling an end of the sleeve 1 is secured to the end of the hub 3 by screws 13 or the like.

Ball or roller bearings 2 are provided that have their raceways inner in abutment with the shoulders 1' of the sleeve while their outer raceways fit within the hollow hub 3 to support the hub for a freely rotative movement about the said sleeve. As will be seen, by the means of these free running bearings 2, the cutter hub in its rotation will not impart a rotative action to the sleeve. While the device here shown includes ball bearings between the hub 3 and sleeve 1 it is obvious that if desired the bearings may be omitted and that an equally freely rotative movement of the cutting element upon the sleeve may be facilitated by various other means.

The clamping nut 6 previously referred to is provided with an internal screw thread 8 adapted for engagement with the male thread 5 of the hub 3 and is provided with suitable spanner openings 7 to facilitate the turning of the nut upon the end of the hub 3. A pilot flange 9 is provided on the forward face of the nut 6 and is adapted to interfit the usual central opening of the cutter K while the rear wall of the said nut is provided as shown with an annular opening 10 through which an end of the sleeve 1 may project.

The disk cutter K is securely clamped by and between the nut 6 and hub flange 4 as shown, wherein it will be seen that the cutter is dished or concaved to adapt the cutter to a proper shearing and cutting action. The inner face of the nut 6 is adapted to abut the threaded end 5 of the hub whereby the cutter K is securely locked in its dished condition. The concavity of the cutter may be varied as desired by lengthening or shortening the end 5 of the hub which of course permits the nut 6 to be run onto the hub and a greater or less distance depending upon the concavity desired.

The length of the hub is preferably slightly greater than the outside face to face length of the bearings as will be seen, whereby a clearance is provided between the outer bearing faces of the bearing and the inner faces of the said nut 6 and plate 3'. By thus providing clearance, the bearings are not bound or clamped between the nut and plate and the outer raceway of the

bearings may rotate with the hub without exerting a rotative action upon the inner raceways or upon the sleeve 1.

A cup or cap C is provided and fits loosely over the support S and has a slot C' for receiving the latch L, by the means of which the said cup is held from a rotative movement upon the support as in my before mentioned Patent 852,964.

A coil spring 11 is provided that encircles the support S and is adapted when interposed between the sleeve 1 and removable cap C to urge the said sleeve along the support.

It will be seen, that the spring does not bear against or contact with the rotatable cutter hub but that it is interposed between the non-rotative cup that serves as an abutment and a slidable element supporting the rotatable cutter whereby the rotatable cutting unit is urged toward the driving element without impairing the freely rotative movement of the said cutter about the support.

A lever 12 is pivoted to the bracket T and is provided with a cam surface 12' that is adapted to bear against the outer face of the nut 6. The lever is adapted for a swinging movement in a downward direction to move the rotatable cutter to the dotted line in operative position shown in Fig. 2, in which position the cutter K is not engaged or driven by the driving roll R.

It is obvious that many changes may be made in the embodiment of the invention herein described without departing from the scope of the invention. I therefore prefer not to be limited by the foregoing description but rather by the following claims.

Claims:

1. The combination in a slitting cutter of, a rigid support, a sleeve slidable thereon, ball bearings carried by said sleeve in a spaced relation, a cutter hub mounted upon said bearings, a nut and a plate carried by said hub that are adapted to abut the outer faces of said bearings to prevent a substantial relative axial movement of the cutter hub and sleeve, a removable cup mounted adjacent an end of said support, and a spring encircling the said support between the cup and an end of the sleeve for urging the sleeve and cutter along the support without impairing the freely rotative movement of the cutter upon the support.

2. The combination in a cutting device of a rotating driving element with a rotatable cutter adapted to be frictionally engaged and driven by said driving element comprising, a rigid support, a sleeve mounted for an axial movement thereon, a cutter carried wholly by the sleeve and adapted for a freely rotative movement upon the said sleeve, means carried by the support that acts upon the sleeve and that tends to urge the sleeve

and rotatable cutter along the shaft whereby the rotatable cutter may be engaged and driven by the driving element.

3. A slitting device comprising, in combination, co-acting driving and driven slitting elements, a support, a member slidable upon the said support the said driven element being wholly carried by the slidable member and adapted for a freely rotative movement thereon, and means acting upon the sliding member whereby the rotatable driven element is urged into slitting engagement with the driving element and is driven thereby.

4. The combination in a slitting cutter of, a rigid support, a sleeve slidable thereon,

a cutter carried wholly by the sleeve and adapted for a freely rotative movement thereon, means associated with the sleeve and cutter to prevent a relative longitudinal movement thereof, a removable cup mounted adjacent the outer end of said support, a spring encircling the support that abuts the said cup and an end of the sleeve for urging the sleeve along the support without impairing the freely rotative movement of the cutter upon the support.

In testimony whereof we have affixed our signatures.

CHARLES KOEGEL.
FREDERICK W. KOEGEL.
HERMAN I. KOEGEL.