

May 9, 1933.

W. H. YOST

1,908,096

DUMP CAR

Filed Sept. 5, 1930

4 Sheets-Sheet 1

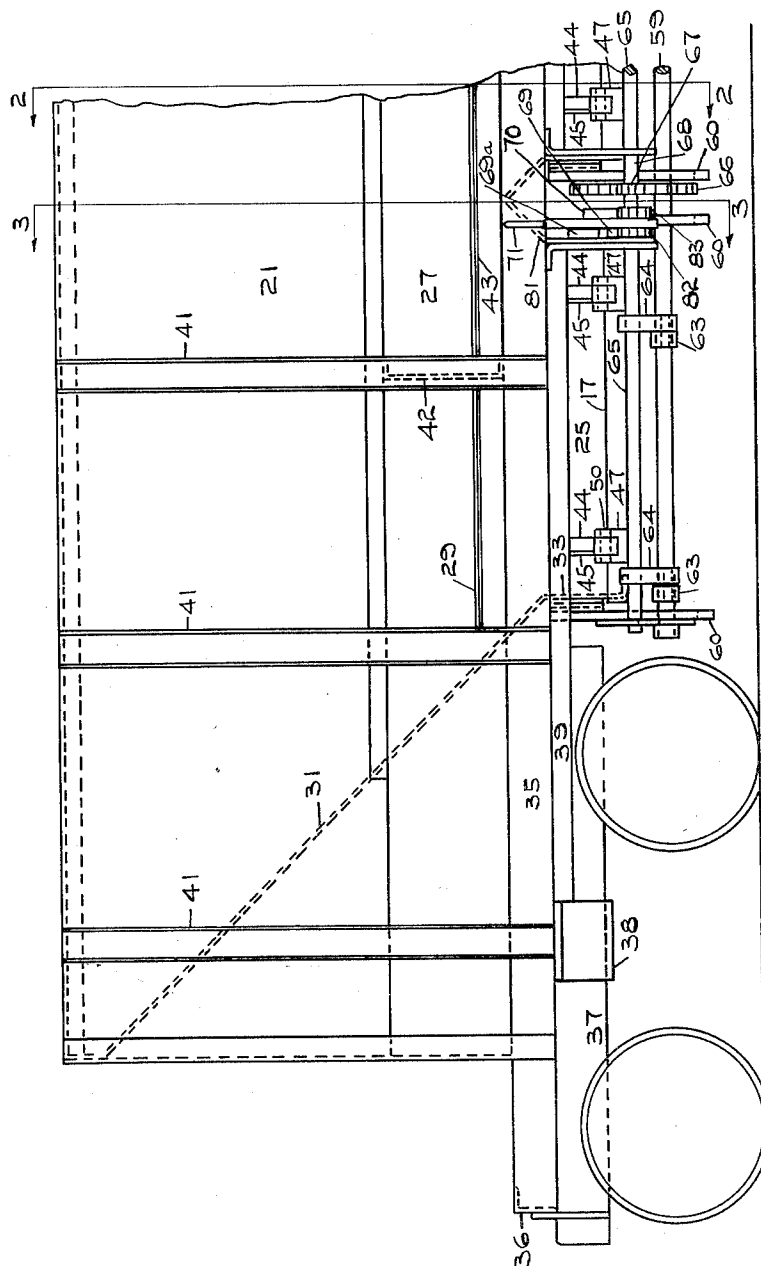

FIG. 1

INVENTOR.  
W. H. Yost.  
By  
C. J. Kehring & Co.  
ATTORNEY.

May 9, 1933.

W. H. YOST

1,908,096

DUMP CAR

Filed Sept. 5, 1930

4 Sheets-Sheet 2

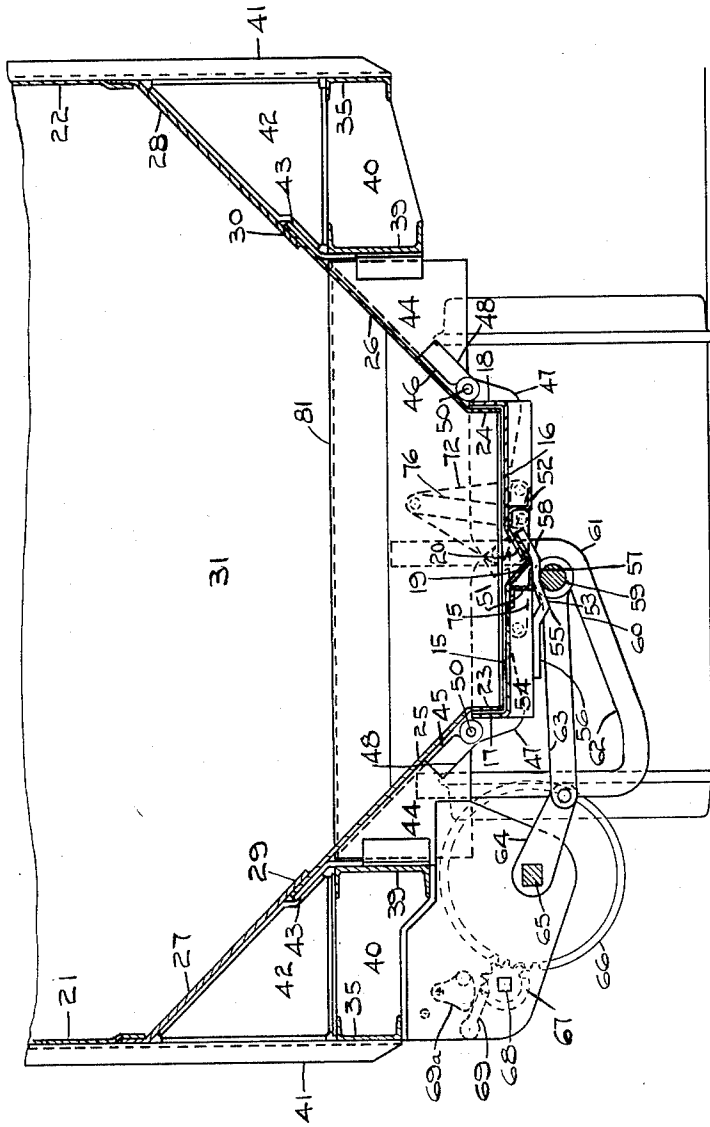

FIG. 2

INVENTOR  
W. H. Yost.  
L. J. Scheraboung  
ATTORNEY.

May 9, 1933.

W. H. YOST

1,908,096

DUMP CAR

Filed Sept. 5, 1930

4 Sheets—Sheet 3

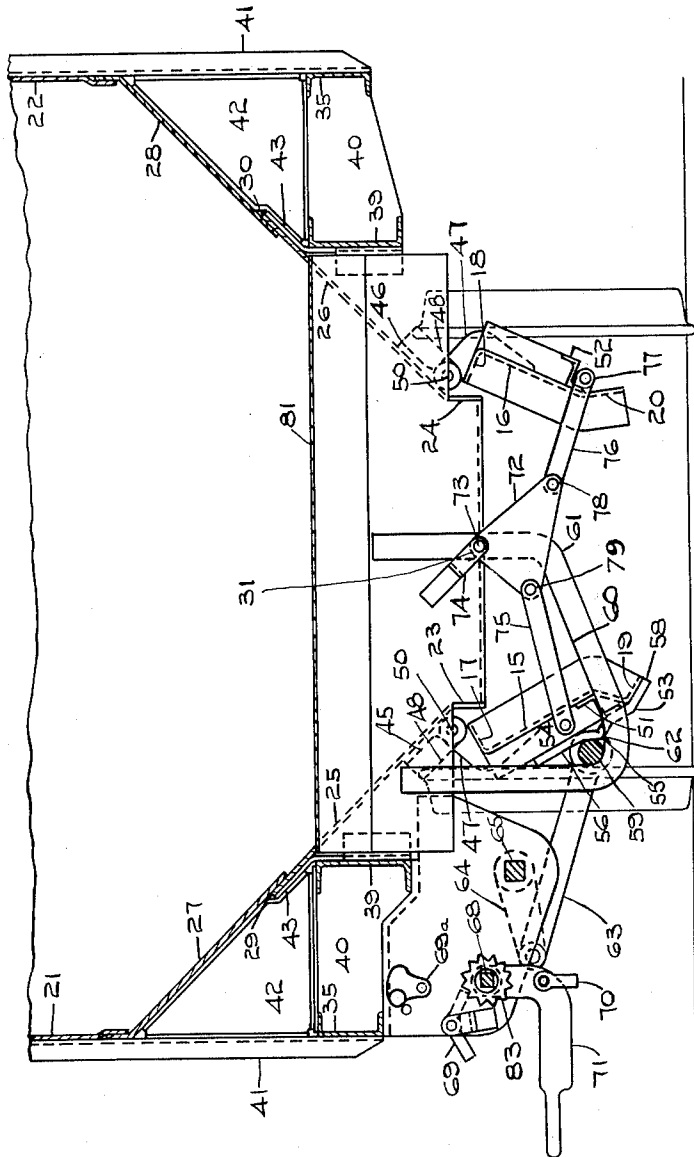

FIG. 3.

INVENTOR  
W. H. Yost  
E. J. Ketherstonhaugh  
ATTORNEY

May 9, 1933.

W. H. YOST

1,908,096

DUMP CAR

Filed Sept. 5, 1930

4 Sheets-Sheet 4

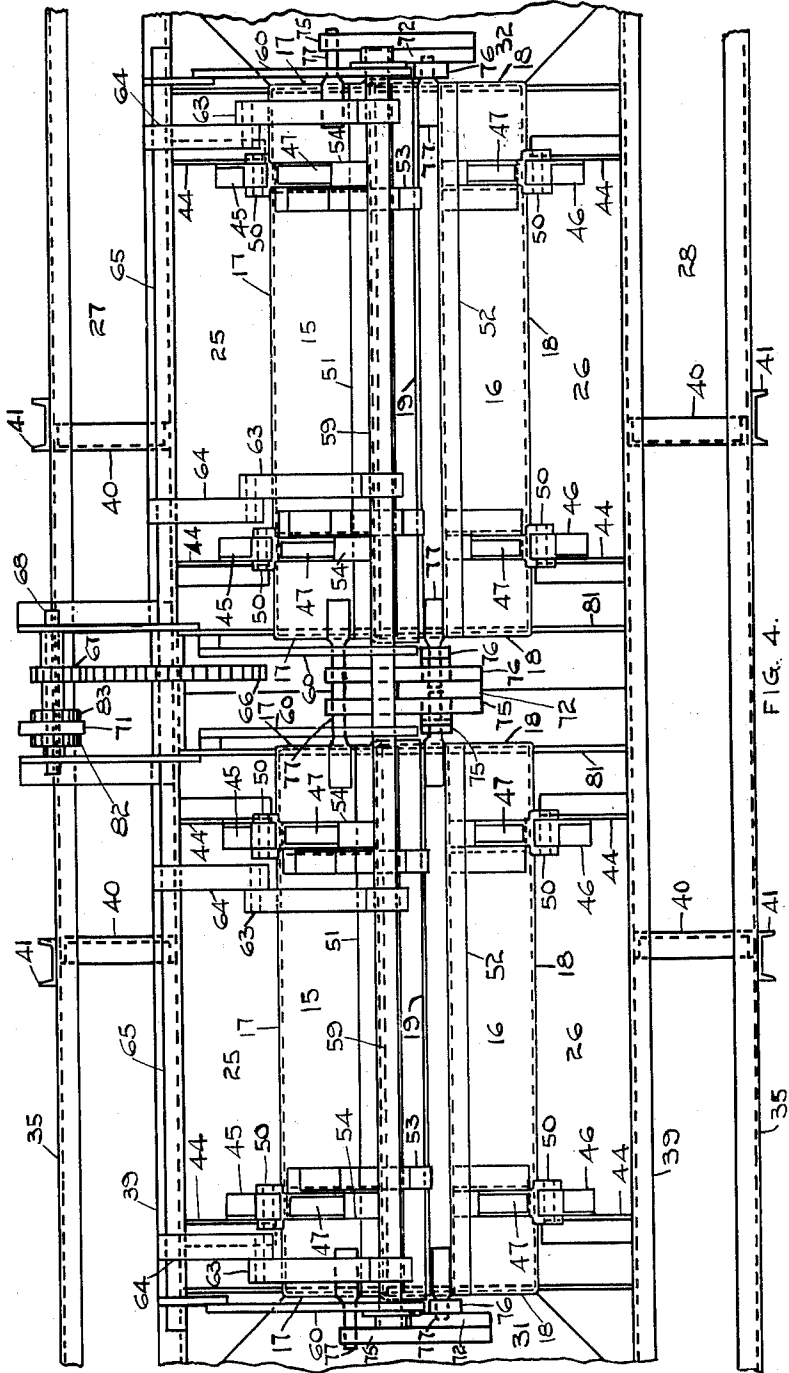

FIG. 4.

INVENTOR.  
W. H. Yost.  
C. J. Schenck & Co.  
ATTORNEY.

## UNITED STATES PATENT OFFICE

WINFIELD HANCOCK YOST, OF MONTREAL, QUEBEC, CANADA

## DUMP CAR

Application filed September 5, 1930. Serial No. 479,884.

The invention relates to dump cars, as described in the present specification and illustrated in the accompanying drawings that form part of the same.

The invention consists essentially in tightening joints incident to the application of closures to openings in the bottom or walls of a car as pointed out in the claims for novelty following a description of the preferred constructional features.

The objects of the invention are to eliminate the leakages and the consequent losses of valuable cargoes transported in dump cars, where it is essential for despatch and the release of the cars to discharge the contents of the car body without delay, as under existing conditions this is usually done by dropping the product or material into pits prepared for the purpose, and in order to avoid any change of existing methods, this invention insures the tight body, whereby semi-fluid substances, such as concentrates or even very finely divided flowing material will be held safely from the beginning to the end of the journey; to maintain the closures in a reliable and effective close fitting joint in relation to one another and to the car body without in any way complicating the opening and shutting mechanism, for it is well known in the art that dump car doors or gates are not handled with the greatest care, being subject to manipulation, often by rough and unintelligent men, thereby making it actually a necessity to use only the simplest methods for operating the closures; to time the operation of the doors automatically in central discharge dump cars, so that one door will follow the operation of the other door and close in tightly thereon to effect the joint and form therewith a pan for sealing purposes; and generally to provide improved transportation facilities for flowing substances in cars having the gravity discharge openings and closures therefor.

In the drawings, Figure 1 is an elevation view of the car broken away.

Figure 2 is a cross sectional view on the line 2—2 in Figure 1, showing the doors closed.

Figure 3 is a cross sectional view on the line 3—3 in Figure 1, showing the doors open.

Figure 4 is a plan view showing the operating parts and mechanism thereto broken away from either end.

Like numerals of reference indicate corresponding parts in the various figures.

In the modern commercial method of the handling of ore from the mines to a distant smelter, the ore is put through a process at the mines where all the foreign matter is removed as far as possible in order that nothing but pure ore is transported.

This method makes a great saving in cost of the production of the finished product.

The ore when ready for transport from the mines is ground very fine and is often saturated with water, making it almost a liquid substance. Consequently the vehicle used for the transportation of the semi-fluid substance must be tight.

The vehicle generally used is the hopper type of dumping car with doors in the bottom for discharging the contents between the rails at destination. As heretofore it has been impossible to obtain a car with doors tight enough to retain the semi-fluid ore without leaks, notwithstanding that the shipper calks the joints around the doors with bagging or other packing, this invention has been made in order to avoid the losses from this very valuable ore. This calking and the loss of ore means a higher cost in the manufacture and refining of the finished product.

Referring to the drawings, the doors 15 and 16 form in their closed position a sealing pan having the flanges 17 and 18 upturned at the outer edges to form this pan.

The door 15 terminates inwardly in the V-shaped flange 19, while the door 16 terminates inwardly in the bevel flange 20, fitting into the V-shaped flange 19.

The hopper floors 21 and 22 are offset downwardly at their lower ends 23 and 24 and fit into the pan formed by the doors 15 and 16, and these offsets 23 and 24 are at the lower ends of the floor plates 25 and 26, while the plates 27 and 28 extend from the

floor plates 25 and 26 and overlap the latter at the joints 29 and 30.

The end hopper walls 31 and 32 extend downwardly and are offset at 33 and 34 into the pan formed by the doors. These hopper walls, the ends and the sides, together with the doors form the body of the car and the receptacle for the cargo, and it will be noticed that the pan formed by the doors, and having the walls projecting downwardly thereinto forms a perfect seal for any semi-fluent cargo where there is a settling effect.

The sediment in semi-fluent cargoes, such as concentrates, will form a stiff mixture of a clayey consistency, which fills up the pan and completely immerses the flanges from the walls projecting into the pan, so that no fluid can readily pass this seal nor can it pass the seal formed by the door flanges, consequently there is no leak at all from the bottom of the car, as the receptacle is effectively sealed by the cargo itself, that is to say, by the collected solids of the cargo.

The body of the car just described is supported by the frame, which is of substantial construction and comprises the side sills 35, the end sills 36, the center sills 37 extending from the end sills 36 to the hopper end walls through the body bolsters 38.

The intersills 39 extend between the body bolsters 38 and are connected thereto, and the side sill and intersill separators 40 hold these sills together to form a rigid construction.

The side stakes 41 extend upwardly from the side sills 35 and are rigidly secured thereto and these stakes 41 are connected to the extension plates 27 and 28 by the reinforcing gusset 42.

The reinforcing plates 43 are rigidly secured to the intersills 39 and offset under the joints 29 and 30 and rigidly secured thereto, thus directly supporting the wall plates at their overlaps from the intersills 39.

The gussets 44 extend inwardly from the intersills 39 and are rigidly secured thereto and at their inner ends are rigidly secured to the floor plates 25 and 26, thereby insuring great rigidity in so far as the support of the hopper wall is concerned, especially that part of it that takes the greatest weight.

The hinges 45 and 46 are secured to the gussets 44 and the leaves 47 of these hinges are in angle form and reach over the flanges 17 and 18 and are secured to the undersides of the doors, while the hinge plates 48 are secured to said gussets.

The barrels of the hinges are joined together by the hinge pins 50, so it will be understood from these hinge connections that the doors 15 and 16 are thrown wide, when they drop to their open position and quite clear of the flanges 17 and 18, leaving the discharge opening without interference.

The Z-bars 51 and 52 are secured respec-

tively to the doors 15 and 16 on the underside, the Z-bar 51 being inside the V-shaped flange 19, and extending slightly therebeyond, and forming a support for the shaft guide and lock 53, which is secured to the angle bars 54 rigidly secured to the underside of the door, and extending inwardly to the flange 17.

The shaft guide way 53 is formed with a V-shaped hump 55 extending rearwardly into the section 56 parallel with the door and forwardly into the section 57 parallel with the door and forwardly again into the offset portion 58 backing the extreme section of the V-shaped flange 19.

The shaft 59 slides on the guide 53 and passes over the hump 55 closing and locking the door 15. This shaft 59 is carried on the tracks 60 formed of the substantially U-shaped rails 61 rigidly secured to the frame of the car.

The sections 62 of the rails are inclined upwardly from the outer end to the inner end of the U, therefore the shaft in the outer position allows the door the full swing or wide open position, while the shaft in its inner position binds the door tightly to its closed position.

The shaft 59 is operated through a pitman 63, in which the shaft is mounted at the extreme end of said pitman, this pitman being pivotally connected to the crank 64 mounted on the squared shaft 65.

The shaft 65 carries the gear wheel 66, which coacts with the pinion 67 mounted on the squared shaft 68, the ratchet 82 mounted on the shaft 68 is held by the stop pawl 69 and locked by the pivoted dog 69a in engagement with the pawl 69 and adapted to be swung around out of engagement with the teeth of ratchet 82, allowing the said pawl 69 to slip from tooth to tooth during the operation of the ratchet 82.

The operating pawl 70 engages the ratchet 83 and is operated by the lever 71 and it is by this lever 71 that the shaft 59 is drawn along the tracks 60, so that the doors may be opened or pushed up the incline 62 to close the door 15.

The door 16 is operated by the bell crank 72. The bell crank lever 72 is fulcrumed on a shaft 73 secured to the car by the bracket 74, said crank lever being pivotally connected at one of its angles by the connecting link 75 to the angle bar 54, forming part of the structure of the door 15, thus when the door 15 is moved to its closed position, this movement must affect the position of the bell crank lever 72, and consequently the position of the door 16.

The loose link 76 is pivotally secured at another angle of the bell crank lever 72 and at its end free from the bell crank it is pivotally secured to the trunnion 77 rigidly secured with the structure of the door, thereby con-

necting said door with the bell crank. Consequently when the door 15 is swung to its open position the bell crank lever is reversed bringing the pivot pin 78 of the bell crank

5 lever to a lower position from an upper position and throwing the pivot pin 79 of the bell crank lever to the other side of the pivot pin 73 of the bell crank lever, thus the pin 78 in its lower position will throw the loose links

10 76 outwardly in order to completely clear the discharge opening of the car, while the pin 79 being thrown over beyond the pin 73 connecting the link 75 allows the full swing of the door 15 to clear the discharge opening.

15 The central operating mechanism is shaded by the hood 81, which is shown as extending across the car from sill to sill and rigidly secured, while the end operating mechanism is under the end floors 31 and 32, therefore

20 in unloading the car, no cargo will interfere with the operating mechanism. In the operation of this invention, the receptacle formed by the body of the car and the closed doors, is filled with the semi-fluent

25 substance already mentioned, and which in the present instance is intended to refer to the products of the mines, which have been brought up to a condition where the really valuable metals are in solution after crushing,

30 and which have been named already in this description as concentrates. This material is poured into the receptacle and immediately begins to settle, the heavier more solid portion of the mixture gravitating

35 to the pan at the bottom of the car already described as formed by the doors, and lined around the side walls by the projecting flanges of the hopper walls. This sediment in the pan is really the

40 equivalent of a thick clayey mixture, which fills up all cracks, such as would appear between the linings or flanges on the side walls of the pan or such as would appear between the door flanges.

45 It will thus be seen that the bottom of the receptacle formed by the body is sealed by the very material which forms the cargo and any fluency there is to the material thereabove simply washes about and the valuable contents of it remain in the car and are transported to the destination, where the doors are

50 opened and the complete cargo dropped into a pit. The opening of the doors is accomplished

55 by first swinging the locking dog 69a away from the stop pawl 69, then the lever 71 is operated, which turns the ratchets 82 and 83 by means of the progressive pawl 70. The gear 66 coacts with the pinion 67 and rotates

60 the crank 64, which draws on the pitman 63, thus pulling the shaft 59 along the rails forming the track 60. This brings the shaft 59 over the hump 55 at the same time releasing the door 15. The

65 release of the door is accompanied by the

downward swing of said door and coincidentally the downward swing of the door 16, because the weight above is bound to open these doors.

The bell crank 72 rotates on its fulcrum 70 and really reverses itself, so that the link 76 is carried outwardly by the weight of the door 16 and the link 75 is also carried outwardly by the door 15, but on the other side of the car.

75 It is obvious now that when the receptacle is emptied the movements will be reversed throughout, the lever 71 will of course be operated and this will in turn operate the co-acting ratchet 83 and in this movement the shaft will be forced up the incline track 60 by means of the pitman 63, and crank 64, and coincidentally the connecting link 75 will begin the reversal of the bell crank, that is to say, the bell crank will begin to rotate just as soon

80 as the shaft begins to travel up the tracks, for as the door 15 swings upwardly, the bell crank swings on its fulcrum 73 and the link 76 begins to lift the door 16.

85 The closing mechanism of the door 16 is so arranged that its movement is quicker than the door 15, until the V-flange 19 is in lifting position in relation to the bevel flange 20, that is to say, therebelow, then the bell crank reaches a position where its section connected to the connecting link 75 is practically horizontal and this causes a pause for the connection of the closing link is practically center for a moment, and this pause in the operation of the door 16 permits the V-

90 shaped flange of the door 15, which is constantly moving to close up on the bevel flange 20, which it immediately crowds to its closed position, thereby bringing the two flanges in very intimate relationship as the shaft 59 is clamping the V-shaped flange 19 tightly to the bevel flange 20 through the shaft guide 53, and no weight from above, due to the loading of the cargo can release this shaft from its clamping position, as the hump 55 is

95 now behind the shaft and any pressure from above will in no way affect the position of the shaft other than to exert still greater pressure from beneath, through the engagement of the said hump.

100 The car body is now ready for loading purposes, and the pan bottom has been restored to its original position for sealing purposes, and it will be noticed that the end flanges of the doors overlap in their closed

105 positions correspondingly to the overlapping closure flanges.

110 What I claim is:—

1. In a dump car, a body forming the cargo receptacle and having a suitable discharge opening, hinged horizontal doors closing said opening and having overlapping offsets forming a longitudinal channel for a sediment seal, and means for operating said

115 doors.

2. A dump car, comprising running gear, a frame, a hopper receptacle supported in said frame and having a central discharge opening, brackets rigidly secured to said frame, a pair of folding doors having inturned side and end flanges forming together a pan and hinges having angularly offset levers secured to the doors and plates secured to said brackets, and means supported by the car frame for clamping one of said doors to its shut position and coincidentally shutting the other door in with it.

3. In a dump car, a body having walls adapted to gravitate the contents to the discharge end and a flat pan bottom in centrally overlapping sections forming a central sealing channel therealong and turned up at the edges to cap said discharge end and means for operating said sections and retaining them in their closed position.

4. In a dump car, a body having walls adapted to gravitate the contents to the discharge end and a flat pan bottom in centrally overlapping sections having a cap flange receiving a flange overlap and forming a longitudinal central sealing channel and also having upstanding outside edge flanges capping said discharge end and means for operating said sections and retaining them in their closed position.

5. In a dump car, a hopper body forming a central longitudinal discharge opening, swing doors closing said opening and having side and end flanges cooperating with the ends of the hopper walls and the hopper body contents in forming tight joints and centrally meeting in overlapping angular flanges to form a tight joint and means for operating said doors, said means supporting one door directly and the other door indirectly in the closed position.

6. In a dump car, a body converging to a central discharge opening, doors swinging widely from said opening and closing tightly thereto and having overlapping angular meeting flanges, and side flanges and end flanges fitting tightly over the projecting lower ends of the body walls and means for operating said doors.

7. In a dump car, a body forming the cargo receptacle and having a suitable discharge opening, hinged doors closing said opening, and means for shutting and releasing said doors having connections from door to door in the operating mechanism adapted to vary the relative speeds of the doors in their closing movements, for the purpose set forth.

8. In a dump car, a body forming the cargo receptacle and having a suitable discharge opening, hinged doors closing said opening, and operating mechanism for clamping and releasing said doors and having interconnecting means for timing the movement of one door in relation to the other door to seal the joint therebetween when closed.

9. In a dump car, a body forming the cargo receptacle and having a suitable discharge opening, hinged doors closing said opening and clamping mechanism cooperating with lever mechanism in closing and releasing the doors and having link members coacting with a bell crank member in timing the operation of the doors in relation to one another, to positively place one door under the other door at their meeting edges to seal the joint therebetween.

10. A door operating mechanism comprising a slidable shaft in constant engagement with a flanged door and supported on track bearings, a ratchet and crank mechanism for sliding said shaft and link connections to a companion flanged door, said sliding shaft adapted to wedge one of the doors up to and under the meeting edge of the companion door in closed position to seal the joint therebetween.

11. In a dump car, a pair of oppositely hung pan doors and mechanism for operating said doors providing a stop for one of the doors in its open position and a support for both doors in their closed position and means connecting said oppositely hung doors, said mechanism including timing means for the operation of one of the doors in its movements relatively to the movements of the other door, so that the closing movement of one door will be faster than the other door until said door is almost closed, then slower until the opposite door comes into contact underneath to force the same shut and seal the joint therebetween.

12. In a dump car, a pair of oppositely hung overlapping doors, said doors making a tight joint with the car frame on three sides, operating mechanisms for said doors means whereby the operation of one door opens and closes the other and automatically tightens the overlapping joint of the doors on the increase of cargo weight.

Signed at Montreal, Canada, this 24th day of July 1930.

WINFIELD HANCOCK YOST