



US00D744618S

(12) **United States Design Patent**
Gooding

(10) **Patent No.:** **US D744,618 S**

(45) **Date of Patent:** **** Dec. 1, 2015**

(54) **FLANGE SHIELD**
(71) Applicant: **Thermaflue Systems Limited,**
Doncaster (GB)
(72) Inventor: **David Gooding,** Doncaster (GB)

6,640,825 B2 * 11/2003 McAtarian 137/312
D486,205 S * 2/2004 Petschek D23/249
6,907,907 B2 * 6/2005 Maida 138/149
D605,900 S * 12/2009 Bodum D7/607
7,637,288 B2 * 12/2009 Kressierer/Huber et al. . 138/149
8,944,092 B2 * 2/2015 Earp 137/313
2004/0168754 A1 * 9/2004 Chen 150/156

(73) Assignee: **Thermaflue Systems Limited (GB)**

FOREIGN PATENT DOCUMENTS

(**) Term: **14 Years**

GB 2509834 A 7/2014

(21) Appl. No.: **29/492,858**

* cited by examiner

(22) Filed: **Jun. 3, 2014**

Primary Examiner — John Windmuller

Assistant Examiner — Steven Czyz

(30) **Foreign Application Priority Data**

(74) *Attorney, Agent, or Firm* — Clark Hill PLC; James R. Foley

May 6, 2014 (WO) DM/083 617

(51) **LOC (10) Cl.** **23-01**

(52) **U.S. Cl.**
USPC **D23/259**

(58) **Field of Classification Search**
USPC D23/259–265; 285/45, 47, 53; 150/156,
150/901; 138/149; 137/375, 377, 382
See application file for complete search history.

(57) **CLAIM**

The ornamental design for a flange shield, as shown and described.

(56) **References Cited**

DESCRIPTION

U.S. PATENT DOCUMENTS

2,985,552 A * 5/1961 Watanabe 150/156
3,116,774 A * 1/1964 Callahan 220/200
4,039,098 A * 8/1977 Stilts 220/694.1
4,207,918 A * 6/1980 Burns et al. 137/375
4,489,473 A * 12/1984 Nakagami 29/451
4,556,082 A * 12/1985 Riley et al. 137/375
D293,703 S * 1/1988 Kaye D23/249
4,925,605 A * 5/1990 Petronko 264/46.6
5,158,114 A * 10/1992 Botsolas 138/149
5,522,433 A * 6/1996 Nygaard 138/149
5,878,776 A * 3/1999 Love 137/375
6,520,201 B2 * 2/2003 Sweeney et al. 137/377

FIG. 1 is a top view of an unfolded flange shield;
FIG. 2 is an enlarged view of the unfolded flange shield taken along line 2-2 as illustrated in FIG. 1;
FIG. 3 is a side view of the folded flange shield;
FIG. 4 is an enlarged view of the folded flange shield taken along line 4-4 as illustrated in FIG. 3;
FIG. 5 is a side-front view of the folded and joined flange shield;
FIG. 6 is a front-side view of the folded and joined flange shield;
FIG. 7 is a top view of the folded and joined flange shield; and,
FIG. 8 is an enlarged view of the folded and joined flange shield taken along line 8-8 as illustrated in FIG. 7.
The broken lines represent stitch lines and form no part of the claimed design.

1 Claim, 8 Drawing Sheets

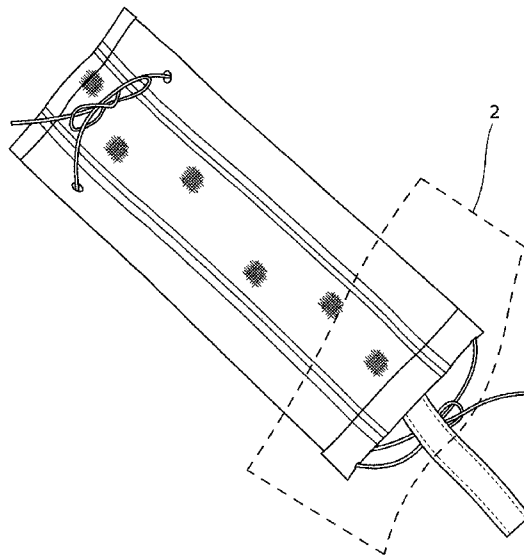

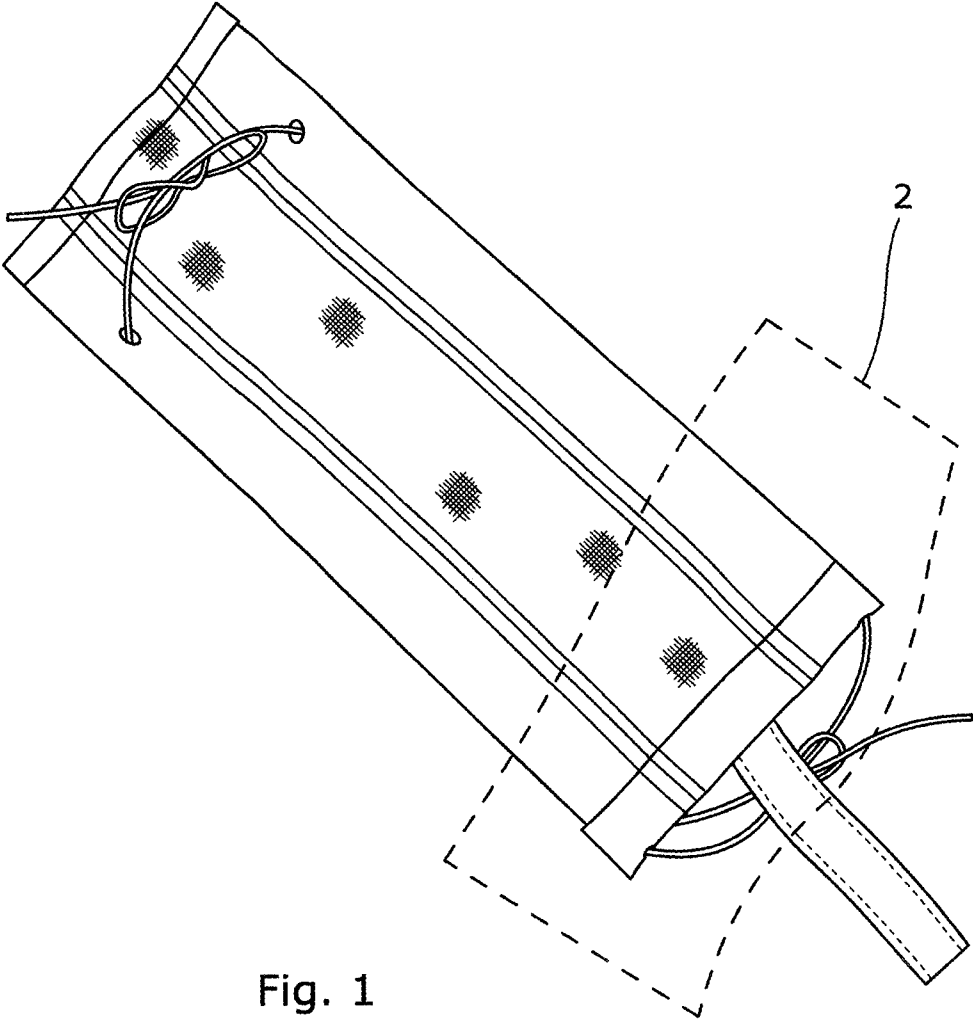

Fig. 1

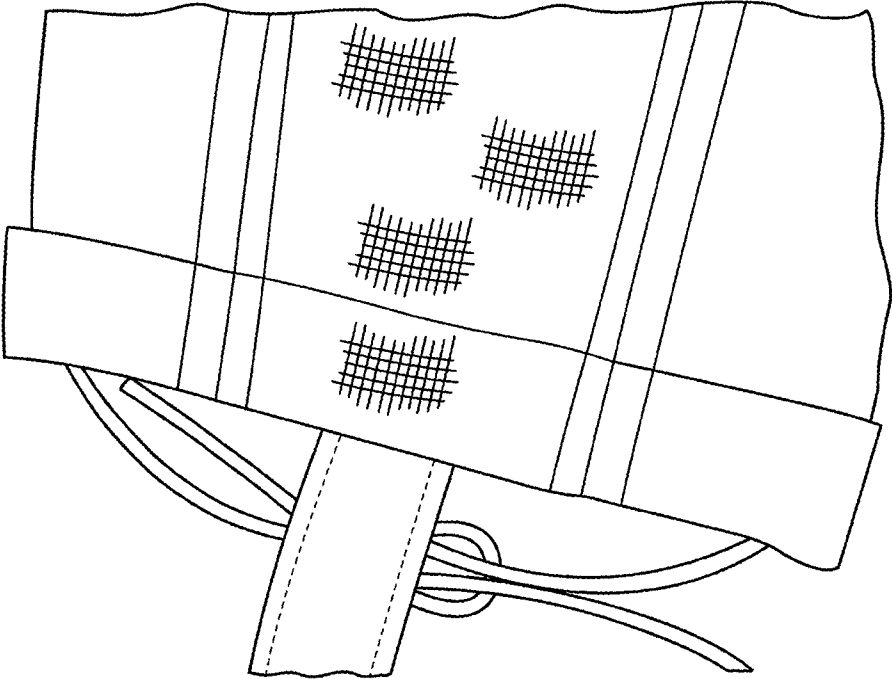

Fig. 2

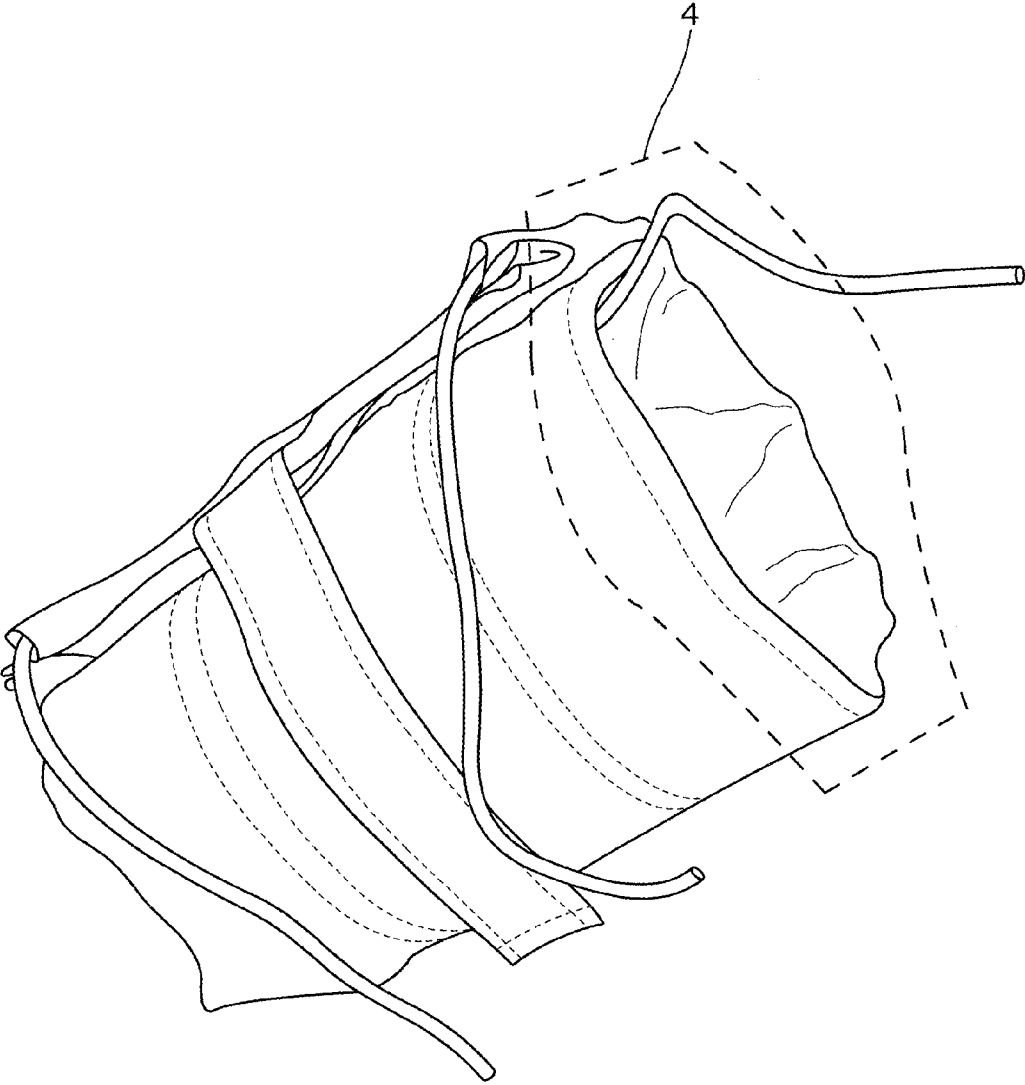

Fig. 3

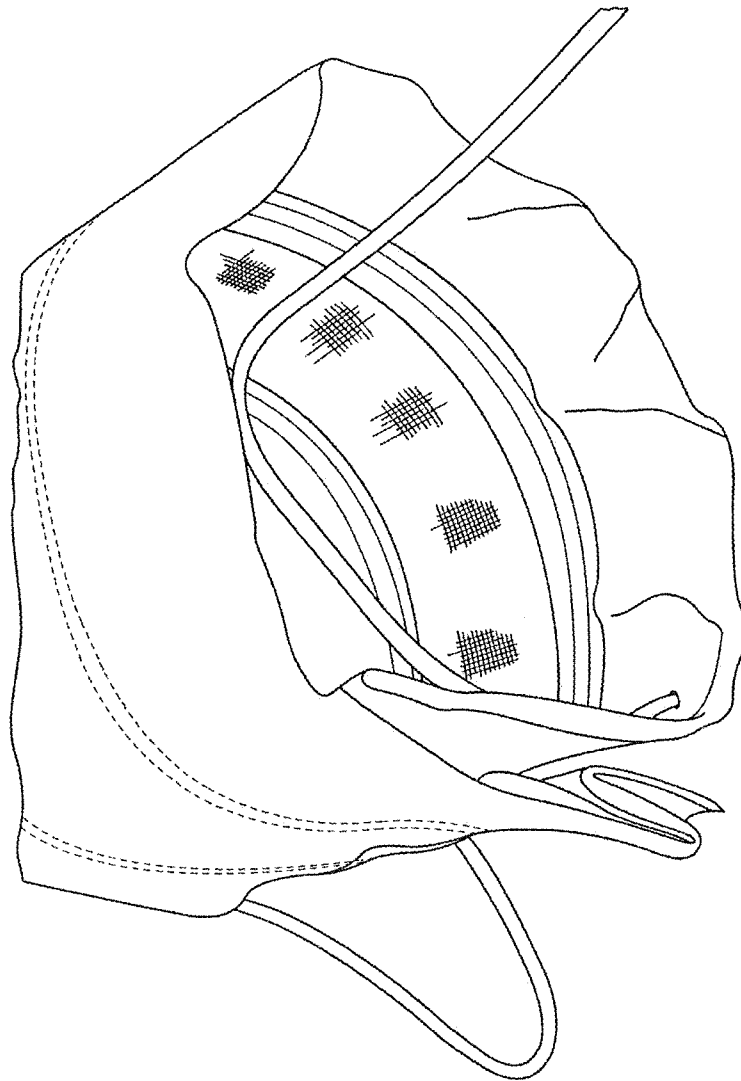

Fig. 4

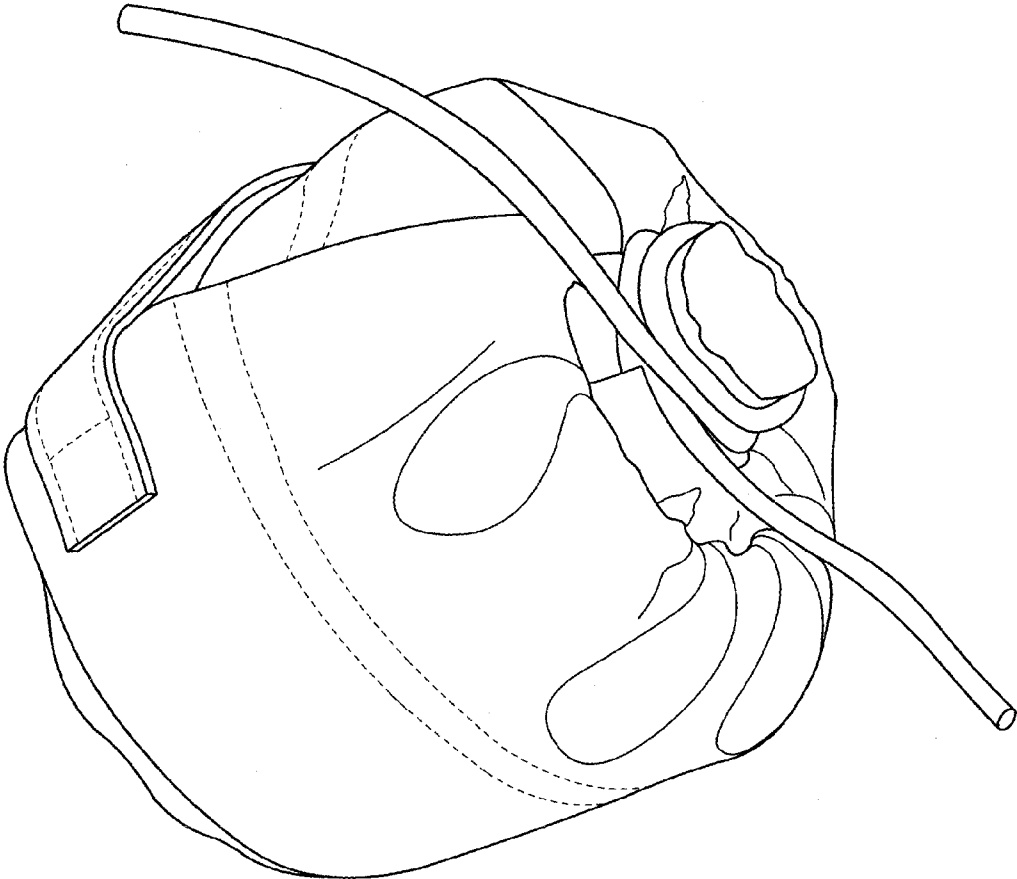

Fig. 5

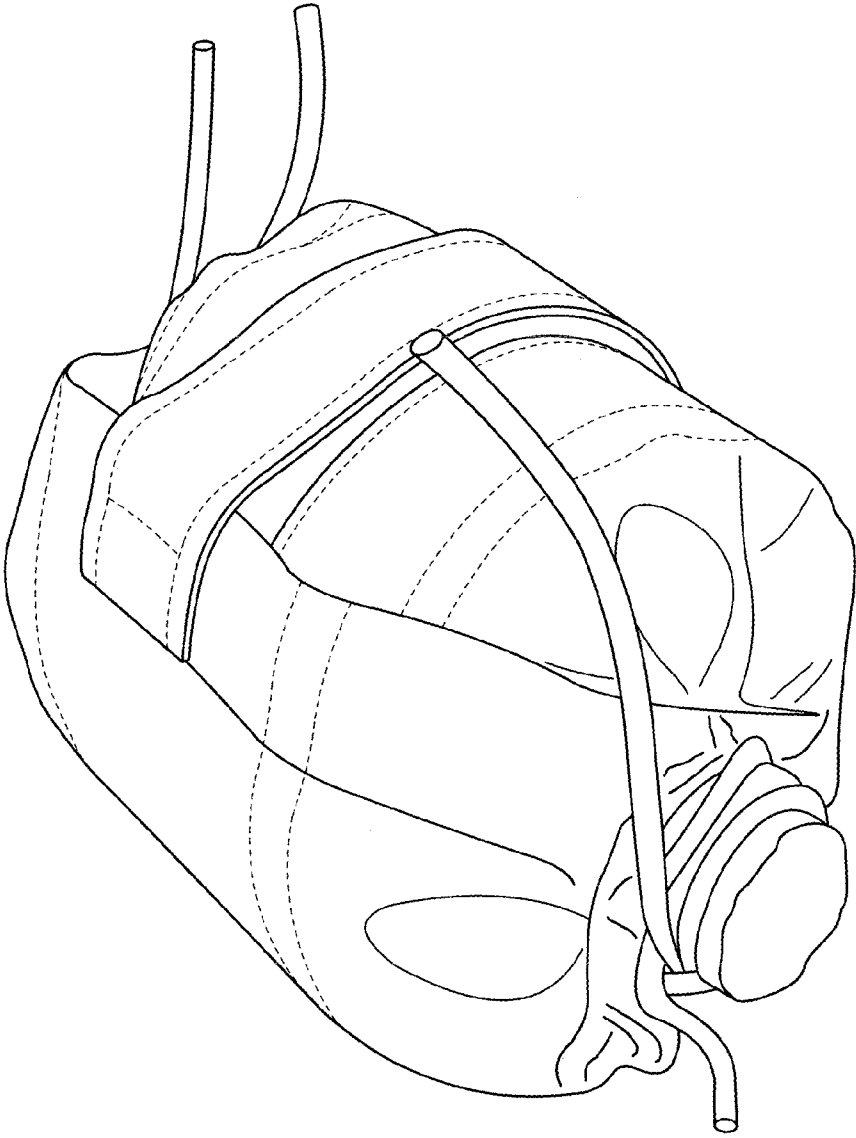

Fig. 6

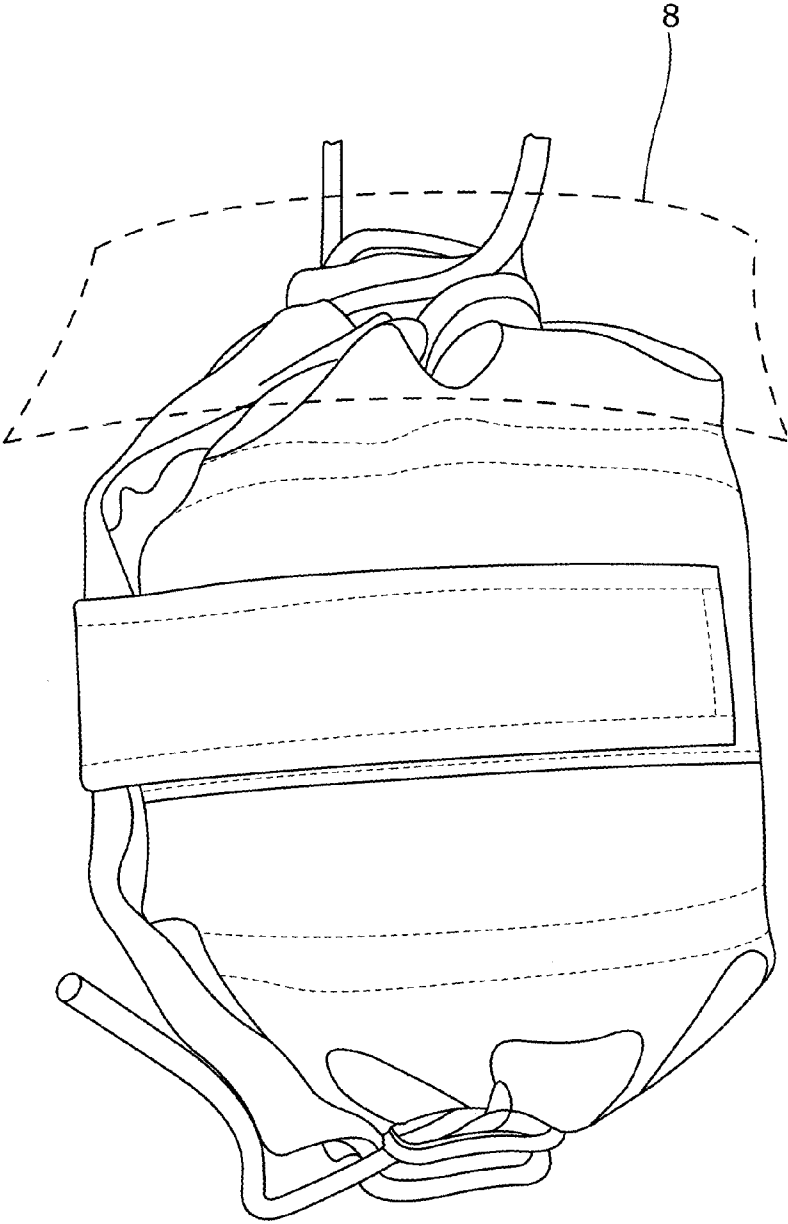

Fig. 7

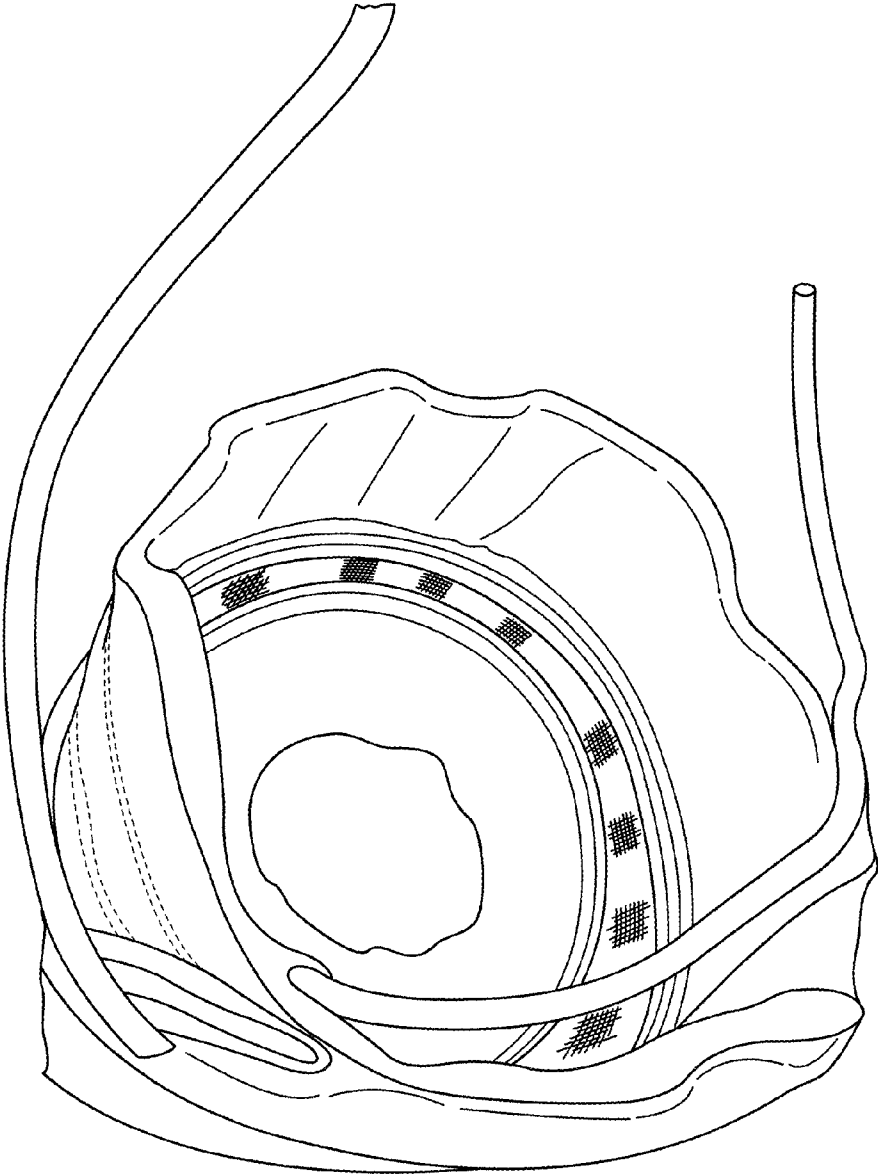

Fig. 8