



(11) (21) (C) **2,128,299**
(22) 1994/07/18
(43) 1995/01/27
(45) 2000/11/14

(72) Winter, Ari, FI

(72) DE JONG, JOHANNES, FI

(73) KONE Oy, FI

(51) Int.Cl.⁵ B66B 1/14

(30) 1993/07/26 (FI 933340) FI

(54) **PANNEAU A POUSSOIRS POUR ASCENSEUR**

(54) **PUSH BUTTON PANEL FOR AN ELEVATOR**

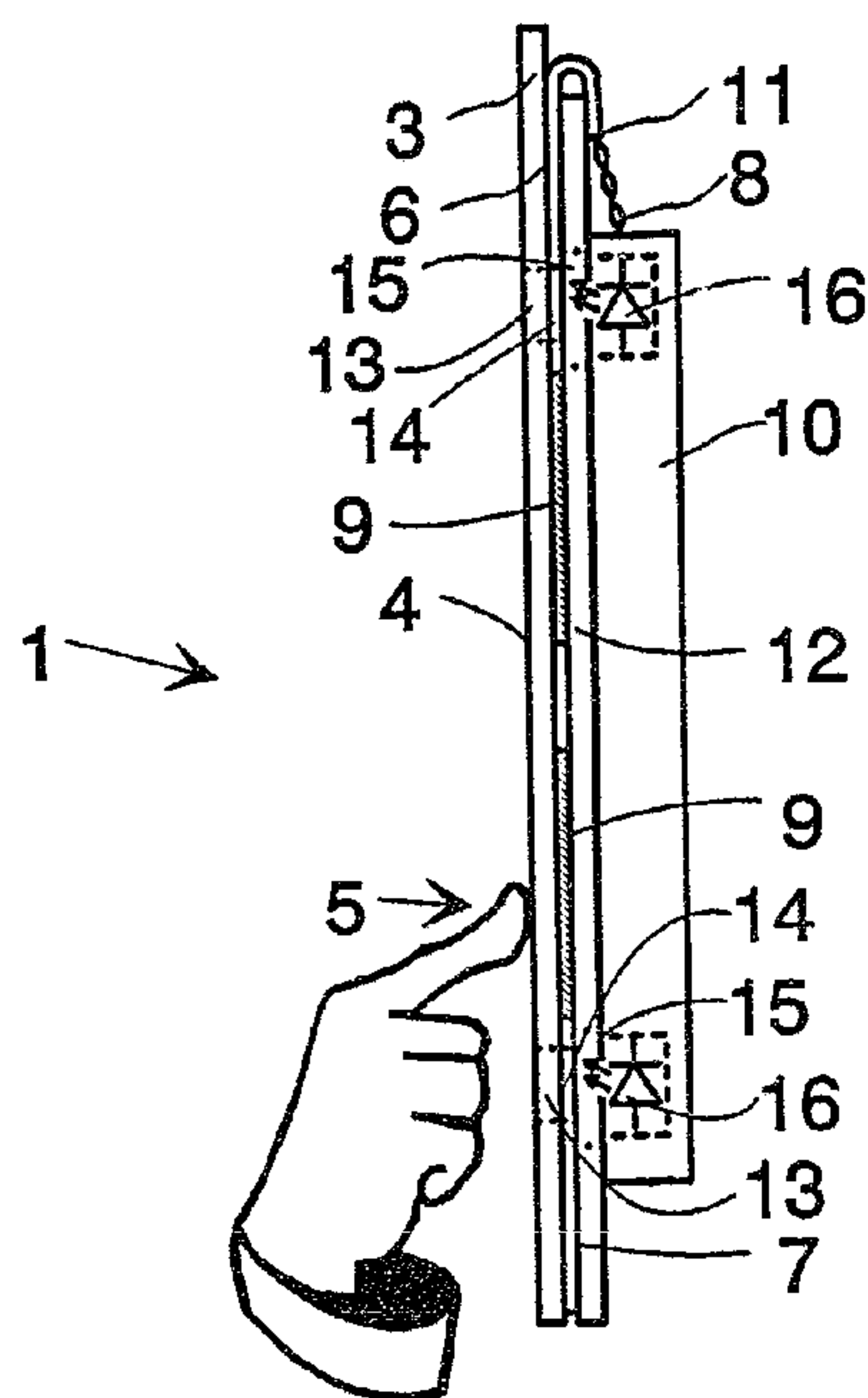

(57) The invention relates to a push button panel for an elevator. The push button panel comprises a front panel and push button areas provided on the front surface of the front panel. The front panel is made of a material having a high degree of rigidity. At least in the regions of the push button areas, the back surface of the front panel is provided with elements sensitive to pressure changes. The sensor element is connected by at least one signal conductor to the data transmission system of the elevator. The sensor element preferably consists of a film which, when subjected to mechanical work, produces an electrical signal.

2128299

ABSTRACT OF THE DISCLOSURE

The invention relates to a push button panel for an elevator. The push button panel comprises a front panel and push button areas provided on the front surface of the front panel. The front panel is made of a material having a high degree of rigidity. At least in the regions of the push button areas, the back surface of the front panel is provided with elements sensitive to pressure changes. The sensor element is connected by at least one signal conductor to the data transmission system of the elevator. The sensor element preferably consists of a film which, when subjected to mechanical work, produces an electrical signal.

PUSH BUTTON PANEL FOR AN ELEVATOR

The present invention relates to a push button panel for an elevator.

5 Elevators are normally operated by pressing push buttons placed in elevator cars or on landings near elevator doors. The signal issued by a push button is transmitted either directly or after processing to an elevator control system, which usually indicates receipt of the information
10 by feeding back an acknowledgement signal to the push button itself or to a device placed near it. This acknowledgement signal often takes the form of a signal light. In practical terms, the push buttons for an elevator can be implemented in various ways and, under normal conditions and if properly
15 used, the various solutions employed generally work without problems.

In certain locations and under certain conditions, improper and sometimes violent treatment of elevator push buttons becomes a problem. Vandalism directed at the push
20 buttons or associated equipment may, apart from damaging the particular equipment, disturb the whole elevator system. For instance, an elevator calling device on a landing may be damaged by having its parts stuck in a position where a call signal is continuously transmitted. Push buttons may also
25 be jammed with chewing gum, sticks, tape and similar items so that they remain in a continuous active position. The structure and material of conventional push buttons usually are not designed to withstand abnormal service conditions.

There are several known solutions for handling the
30 push button abuse described above, involving push buttons capable of withstanding rough treatment and exceptionally difficult service conditions. However, those solutions are both expensive and complicated.

The object of the subject invention is to produce
35 a new elevator push button panel which is as insensitive to external disturbances as possible but which still provides highly-reliable transmission of call signals to the elevator

control system. The panel of this invention is completely insensitive to normal external disturbances. Even use of an arm blanche, hammer or other striking tool on the panel will not cause a disturbance in the transmission of calls or in the subsequent operation of the push button panel. The push buttons have no parts protruding from the panel which may be damaged; all functions take place behind a plate or wall and are thus protected. Customers' specific requirements as to the appearance of the push button panel can be easily accommodated, since no expensive specially-designed components are required; instead, a customer's wishes are met by using patterns formed on the panel. Additionally, since the push button panel is of a flat construction, it does not require a deep cavity for its mounting.

According to an aspect of the present invention, there is provided a push button panel comprising: a substantially rigid front plate having a front surface and a rear surface, said front surface including at least one push button area located thereon; a back plate located proximate to said rear surface of said front plate, said back plate including a first aperture; a pressure sensitive film located between said front plate and said back plate and abutting said front plate and said back plate, said pressure sensitive film including a second aperture; at least one signal conductor associated with said pressure sensitive film for conducting a signal produced by said pressure sensitive film; and indicator means aligned with said first aperture and said second aperture for indicating when mechanical work has been applied to the push button area, said indicator means being visible through said first aperture, said second aperture, and a portion of said front plate; whereby mechanical work applied to the push button area is transferred to the pressure sensitive film to produce said signal in said signal conductor.

According to another aspect of the present invention, there is provided a push button panel comprising: a substantially rigid front plate having a front surface and

a rear surface, said front surface including at least one push button area located thereon; a back plate located proximate to said rear surface of said front plate; a pressure sensitive film located between said front plate and said back plate and abutting said front plate and said back plate; at least one signal conductor associated with said pressure sensitive film for conducting a signal produced by said pressure sensitive film; and indicator means for indicating when mechanical work has been applied to the push button area; whereby mechanical work applied to the push button area is transferred to the pressure sensitive film to produce said signal in said signal conductor, and wherein said pressure sensitive film includes a pair of electrodes, and wherein said signal corresponds to a change in capacitance between said pair of electrodes.

According to a further aspect of the present invention, the push button panel of the invention comprises a front plate having a front surface provided with push button areas. The plate is made of a material having a high degree of rigidity. The panel also comprises an element sensitive to pressure changes attached to the backside of the front plate at least in the regions under the push button areas. The pressure-sensitive element is connected by at least one signal conductor to a data transmission system of the elevator.

The panel may also comprise a back plate attached to the backside of the front plate, the pressure-sensitive element being fitted between the front plate and that back plate. The transfer of the signal is so arranged that at least a portion of the transmission path of the signal is between the front and back plates and away from the push button areas. The push button panel may be attached by means of fixing elements to a wall of an elevator car or to a landing wall. The front plate may form part of a plate structure of a wall of an elevator car or a landing wall, with the pressure-sensitive element being attached to the backside of the plate structure; the surface of the car wall

or landing wall may be provided with one or more symbols for designating the push button areas. The panel may further be provided with signalling elements placed near the push button areas for indicating a call received and/or served. The pressure-sensitive element may comprise a film in which at least one of the surfaces is provided with an electrode electrically connected to a signal conductor and in which, at least in the area of the electrode, mechanical work applied to the film produces an electrical change in the electrode.

The invention will next be more fully described by means of a preferred embodiment, utilizing the accompanying drawings, in which:

Figure 1 is a front view of a push button panel of the invention; and

Figure 2 is a side view of the push button panel of the invention.

Push button panels for elevators usually have push buttons for both up calls and down calls. In Figure 1, a push button panel 1 has a pair of call button patterns 2 forming button areas on the surface of the front plate 3 of the panel. The front plate 3 is essentially continuous and even over the whole area of the panel. The call button patterns are created by painting the front panel, gluing a thin surface layer thereon, or through etching, engraving, anodizing or some other process that is compatible with manufacture and produces sufficiently durable patterns.

A side view of the push button panel 1 is shown in Figure 2. The external or front surface 4 of front plate 3, which is visible to the user, is provided with call button patterns 2 as illustrated in Figure 1. The front plate 3 is constructed of a fairly rigid material, for instance, sheet metal with a thickness of one or two millimetres. However, front plate 3 must not be absolutely rigid; instead, it must yield somewhat under applied pressure by bending or slightly locally deforming or a combination thereof. Once the pressure is removed, the plate returns to its previous

shape. For operation of the push buttons, it makes no difference if the front plate 3 is implemented as an integral part of the plate structure of the elevator car wall or landing wall, or is implemented as a separate plate. The plate structure of the elevator car wall or landing wall usually consists of a car wall panel or a landing door jamb sheet, respectively. A deflection sufficient to produce a call signal is produced by pressing at point 5 with a finger. Irrespective of how the front plate 3 is mounted, i.e. by attachment of the plate to the wall structure using fixing elements such as screws or glue placed at a distance of, for example, 5 to 10 cm. from the call button pattern 2, or by integrating it into a larger plate such as a landing door jamb sheet or car wall panel, a large local displacement or pressure due to the deflection of the front plate 3 occurs at the point 5 where the pressure is applied.

Attached to a back surface 6 of the front plate 3 is a film 7, whose deformation produces an electrical signal in a signal conductor 8. Typically the film 7 is very thin, usually only a fraction of a millimetre. In the film 7 a signal is preferably only generated in the film areas 9 that are under the call button patterns 2 marked on front plate 3. The film areas 9 under those push button areas which are active in the signal generation process are not necessarily of the same size and shape as the call button patterns 2.

The signal conductor 8 passes a signal to an electronics unit 10 in the push button panel 1. On the basis of the push button signal, the unit 10 produces the actual call that is sent to the elevator control system through the data transmission system. For purposes of the data transmission system, the electronics unit 10 may be simply an amplifier which amplifies the push button signal. In a system with serial data communication, however, one function of unit 10 is the generation and transmission of messages corresponding to the calls into the serial communication bus in accordance with the bus protocol. The push button signal may initiate a frequency shift in an

oscillation circuit following a deformation of the film 7, owing to a change in capacitance between the electrodes attached to those film areas 9 under the call button areas 2. That capacitance change is transmitted to the oscillation circuit by signal conductors 8. The signal may alternatively be a pulse of electrical energy that is generated in the film when the latter is of a type that converts mechanical energy into electrical energy. In such a structure, the electrodes affect the properties of the film areas 9 under them to generate a signal. For instance, an elastic, electrically-insulating film formed from plastic material and provided on either side with an electrode that is formed by metal deposition, or a plastic conductive film with internal gas bubbles and capable of being compressed by applied pressure may be regarded as functioning in one of the two aforementioned ways. At least a portion of the signal conductors is preferably formed in film 7 in the same way as the electrodes, so that the push button signal is available at an edge of the film 7. The signal conductors formed in film 7 have a sufficiently small area that when a button is pressed those conductors cannot produce a signal of comparable strength to that produced by the film areas 9 under the electrodes. Behind the film 7 is a back plate 12. When the film 7 is compressed between the front plate 3 and the back plate 12, the film 7 is subjected to a stronger pressure; in the result, the signal generated by that pressure is correspondingly greater.

The front plate 3 has two small window openings 13, and the film 7 and back plate 12 may either have holes 14, 15 placed in the area directly under a respective window opening 13, or be translucent. The light from a light emitting diode (LED) 16, which is positioned behind push button panel 1 and is controlled by electronics unit 10, illuminates the window 13. The light from LED 16 is used to indicate the receipt of a call. The window opening 13 is filled with a transparent, possibly coloured, plastic or other window material, or is formed by making a number of

smaller holes and filling them with a window material. Thus it is not possible to insert pointed objects, such as keys or matches into the window opening 13.

5 It will also be apparent to a person skilled in the art that the front plate 3 may be transparent or translucent (for instance, made of smoked glass). The plate may be made of a hard translucent plastic, in which case it is easy to combine the push buttons with signal lights. For instance, a LED or other type of illuminating component may be mounted
10 in the push button area on the backside of the plate. It will also be apparent that the film may have an electrode on one side only, with the other electrode being formed by the conducting mounting base of the film. The film may also comprise two films having an electrode pattern on one side
15 and being layered to form a single structure in regards to capacitance. By using multi-layered film structures and suitably combining the signals obtained from the different layers in an electrical circuit, it is possible to achieve a push button which, when pressed, produces an electrical
20 signal of multiple strength. It should also be apparent that the electronics unit need not necessarily be placed directly behind the push button panel.

25 The invention has been described in terms of a preferred embodiment. However, the description should not be taken as limiting the ambit of patent protection. The ambit of the invention is intended to vary within the limits set out in the claims which follow.

THE EMBODIMENTS OF THE INVENTION IN WHICH AN EXCLUSIVE PROPERTY OR PRIVILEGE IS CLAIMED ARE DEFINED AS FOLLOWS:

1. A push button panel comprising:
 - a substantially rigid front plate having a front surface and a rear surface, said front surface including at least one push button area located thereon;
 - a back plate located proximate to said rear surface of said front plate, said back plate including a first aperture;
 - a pressure sensitive film located between said front plate and said back plate and abutting said front plate and said back plate, said pressure sensitive film including a second aperture;
 - at least one signal conductor associated with said pressure sensitive film for conducting a signal produced by said pressure sensitive film; and
 - indicator means aligned with said first aperture and said second aperture for indicating when mechanical work has been applied to the push button area, said indicator means being visible through said first aperture, said second aperture, and a portion of said front plate;whereby mechanical work applied to the push button area is transferred to the pressure sensitive film to produce said signal in said signal conductor.
2. The push button panel according to claim 1, wherein the signal transfer is so arranged that the signal is transferred, at least through part of the transfer distance, between the plates away from the push button area.
3. The push button panel according to claim 1, wherein the push button panel is attached to an elevator car wall or a landing wall by fixing elements.
4. The push button panel according to claim 1, wherein the front plate forms part of a plate structure of

an elevator car wall or a landing wall and wherein the pressure sensitive film is attached to the backside of the plate structure of the car or landing wall.

5. The push button panel according to claim 4, wherein a front surface of the elevator car wall or the landing wall is provided with symbols indicating push button areas.

6. The push button panel according to claim 1, further including signalling elements placed near the push button areas and designed to indicate a call received and/or to be served.

7. The push button panel according to claim 1, wherein said pressure sensitive film is provided with an electrode electrically connected to said signal conductor and in which, at least in the area of the electrode, mechanical work applied to the film produces an electric change in the electrode.

8. The push button panel according to claim 1, wherein said indicator means is located at a rear side of said back plate.

9. The push button panel according to claim 1, wherein said indicator means comprises at least one light emitting diode.

10. The push button panel according to claim 1, wherein said front plate includes a window through which said indicator means is visible.

11. A push button panel comprising:
a substantially rigid front plate having a front surface and a rear surface, said front surface including at least one push button area located thereon;

a back plate located proximate to said rear surface of said front plate;

a pressure sensitive film located between said front plate and said back plate and abutting said front plate and said back plate;

at least one signal conductor associated with said pressure sensitive film for conducting a signal produced by said pressure sensitive film; and

indicator means for indicating when mechanical work has been applied to the push button area;

whereby mechanical work applied to the push button area is transferred to the pressure sensitive film to produce said signal in said signal conductor, and

wherein said pressure sensitive film includes a pair of electrodes, and wherein said signal corresponds to a change in capacitance between said pair of electrodes.

12. The push button panel according to claim 1, wherein said pressure sensitive film includes means for converting mechanical energy into electrical energy.

13. The push button panel according to claim 1, wherein said indicator means is located at a rear side of said back plate, and wherein said front plate includes a window through which said indicator means is visible.

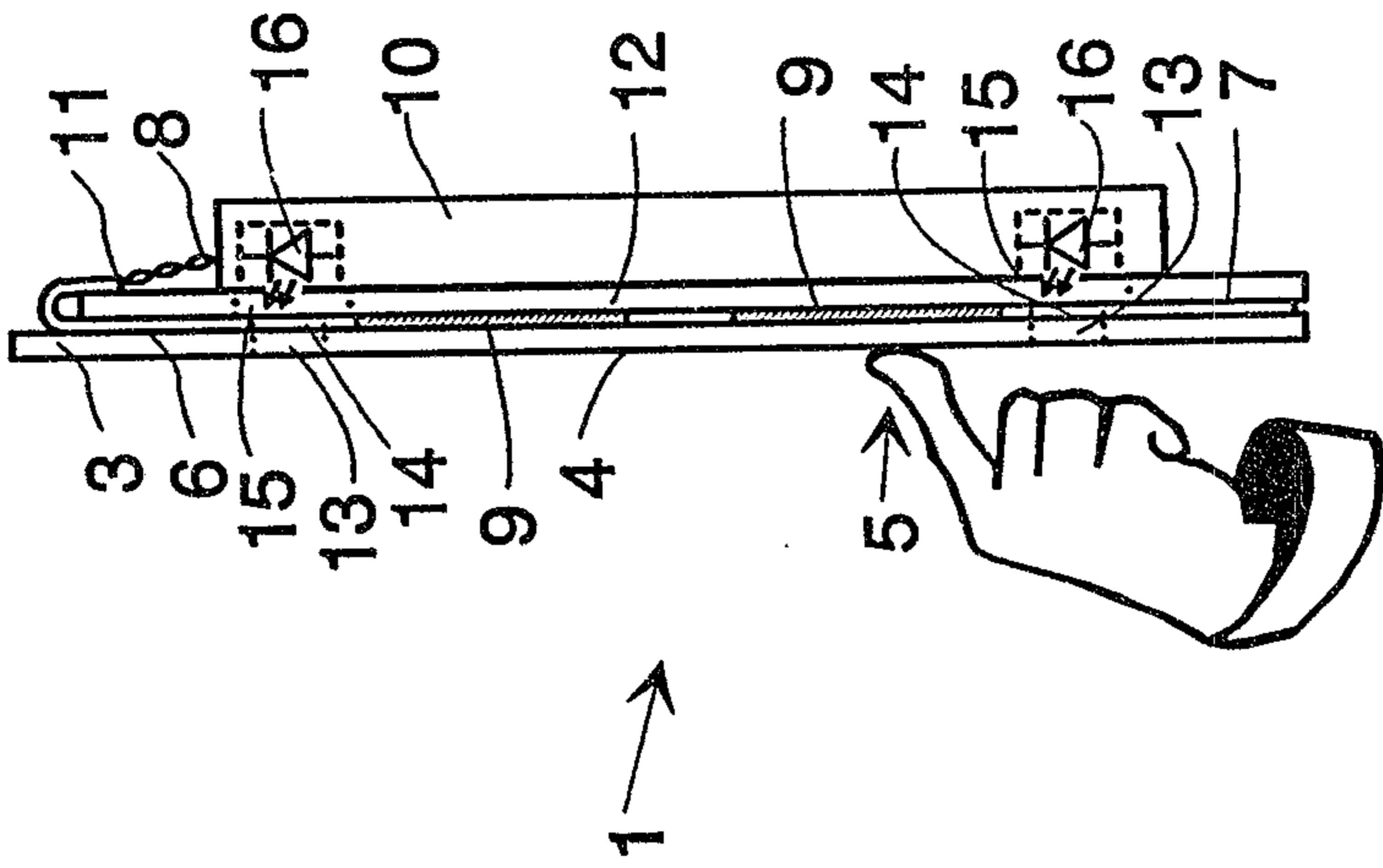

Fig. 2

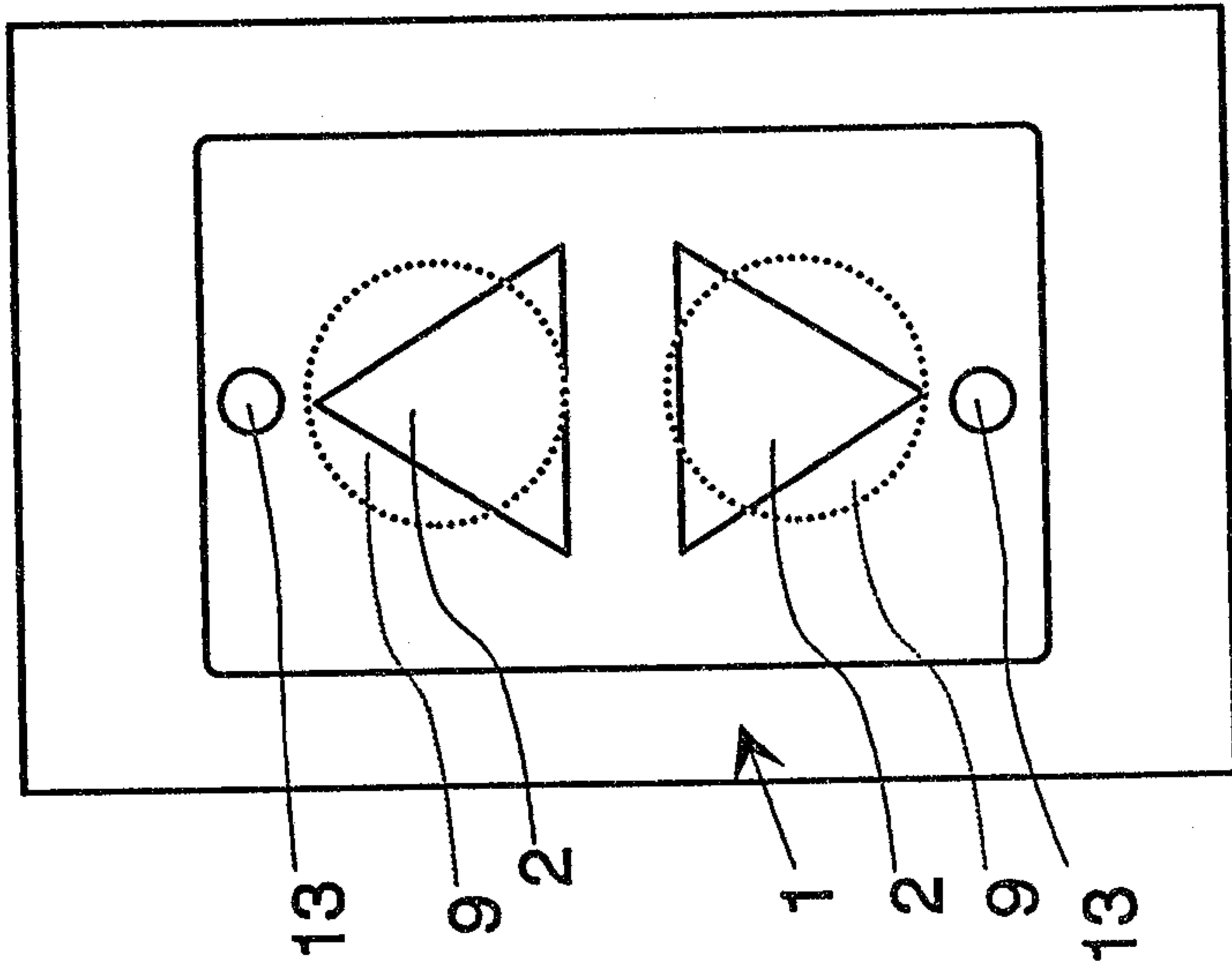

Fig. 1

