

C. VAN HAAGEN,  
Gear Cutting Machine.

No. 110,406.

Patented Dec. 20, 1870.

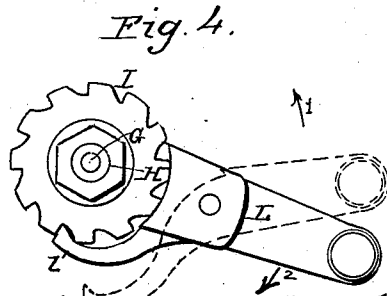
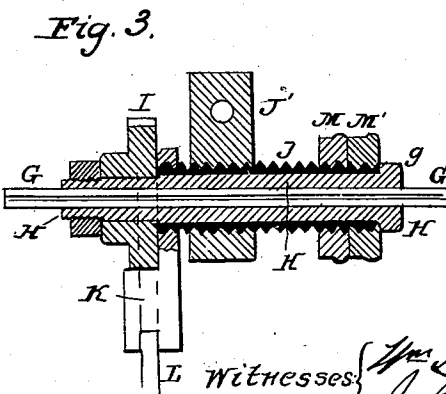
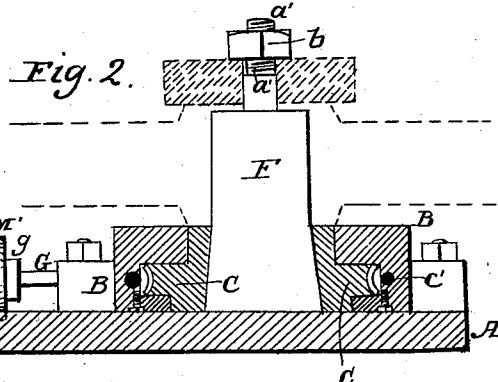
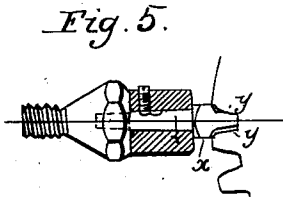
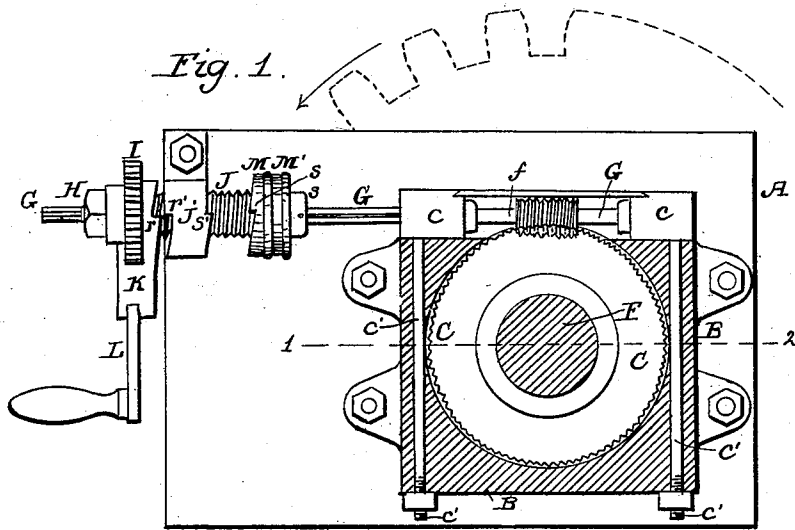

Witnesses: *Wm. Adams*  
*John Parker*

Inventor:  
*Charles Van Haagen*  
by his Attys  
*Houman and Son*

# United States Patent Office.

CLAUS VAN HAAGEN, OF PHILADELPHIA, PENNSYLVANIA, ASSIGNOR TO HIMSELF AND ANTHONY VAN HAAGEN, OF SAME PLACE.

Letters Patent No. 110,406, dated December 20, 1870.

## IMPROVEMENT IN GEAR-CUTTING MACHINES.

The Schedule referred to in these Letters Patent and making part of the same.

I, CLAUS VAN HAAGEN, of Philadelphia, county of Philadelphia, State of Pennsylvania, have invented certain Improvements in Gear-cutting Machines, of which the following is a specification.

### *Nature and Object of the Invention.*

My invention consists of mechanism, too fully explained hereafter to need preliminary explanation, to be used in connection with gear-cutting machines, for the most part as a substitute for the more expensive dividing-plate and other appliances heretofore used.

### *Description of the Accompanying Drawing.*

Figure 1 is a plan view, partly in section, of my improved mechanism for gear-cutters;

Figure 2, a sectional elevation of the same, on the line 1 2, fig. 1;

Figures 3 and 4, detached views of part of the mechanism drawn to an enlarged scale; and

Figure 5, a plan view of part of the wheel, with a cutter operating on the same.

### *General Description.*

To a plate, A, is secured a box or casing, B, in which are contained a worm-wheel, C, and worm *f*, the worm-shaft G turning in bearings *c c* at one side of the said casing.

This worm-wheel is furnished with a spindle, F, extending upward above the casing and terminating at the top in a threaded projection, *a'*, to which is adapted a nut, *b*.

The spindle F, where it passes through the worm-wheel C, is slightly tapering, as shown, and is in contact with the plate A, with which, however, the wheel C is not quite in contact; hence, in screwing down the casing B to the plate the conical portion of the spindle F will be forced tightly into the said wheel.

The bearings *c c* of the worm-shaft G are so controlled by bolts *c' c'*, that, on turning the nuts of the latter, the teeth of the worm *f* may be brought into close gear with those of the wheel, to prevent the possibility of the wheel turning to the slightest extent independently of the worm.

A sleeve, H, having at one end an enlargement, *g*, and at its opposite or outer end a ratchet-wheel, I, is adapted to and arranged to slide longitudinally upon the shaft G, but is prevented from turning independently of the same by a feather adapted to a longitudinal groove cut in the said shaft.

Upon this sleeve there is arranged to turn freely a tube, J, on the entire outer surface of which is cut a screw-thread, corresponding to the internal thread of a stationary nut, J', which is secured to the plate A.

To the outer end of this tubular screw J is perma-

nently secured an arm, K, to which is pivoted a lever, L, having a pawl-like end, *l*, adapted to the teeth of the ratchet-wheel I.

The said tubular screw is also provided with a nut, M, which, when adjusted to any required position, is prevented from accidentally turning by means of a jam-nut, M'.

When the crank or lever L is turned in the direction of the arrow 1, fig. 4, its pawl-like end will be disengaged from the teeth of the ratchet-wheel, so that the screw J will be caused to turn upon the sleeve without imparting any rotary motion to the latter or to the shaft G.

The screw, however, will traverse longitudinally through the fixed nut J' until its movement is arrested by an abrupt shoulder, *r*, on the arm K, coming in contact with a corresponding shoulder, *r'*, on the fixed nut, and the sleeve H will thus have a longitudinal sliding movement, determined by that of the tubular screw.

When the crank or lever is turned in the opposite direction, as indicated by the arrow 2 in fig. 4, its pawl-like end will engage with the teeth of the ratchet-wheel, and will cause the latter, the sleeve H, and the spindle G, as well as the screw, to turn, so that the worm-wheel C and its mandrel will also be turned, and such movement will be continued until, as in the previous case, it is suddenly stopped by an abrupt shoulder, *s*, on the nut M striking a corresponding shoulder, *s'*, on the fixed nut.

It will be evident from the above that the number of revolutions of the screw J and spindle G, and consequently the extent of the movement of the worm-wheel, will depend entirely upon the adjustment of the nut M and the position of its abrupt shoulder in respect to that of the fixed nut.

In using the mechanism for cutting the teeth of gear-wheels the wheel *w*, (shown by dotted lines,) in which the teeth are to be cut, is placed upon the spindle F, and is secured thereto by the nut *b*, as seen in fig. 2.

Mandrels, F, of different lengths and diameters may be used for different wheels, in accordance with the bore and depth of the hubs.

The plate A is placed upon or supposed to form a part of a gear-cutting machine, which is furnished with the usual rose-cutter, caused to revolve and traverse in a manner too well understood by those familiar with tools of this class to need explanation; or, what I prefer, the cutter may be made of the exact shape of the space between two teeth, as shown at *x*, fig. 5, and have two or more cutting-edges, *y y*, the cutter to revolve and at the same time traverse as it cuts away the metal.

The nut M must be so adjusted as to permit the

shaft G to turn a greater or lesser number of times, according to the number of teeth which are to be cut upon the wheel.

Let it be supposed, for instance, that the worm-wheel C has seventy-two teeth, each single revolution of the shaft G will consequently turn it to the extent of one tooth.

If a wheel of seventy-two teeth, therefore, has to be cut, it will be necessary to turn the shaft G but once for every tooth.

Half this number, or thirty-six teeth, would require two turns of the shaft, for each tooth.

In order to illustrate the operation of the machine let it be supposed that a wheel of thirty-six teeth has to be cut.

The crank L is first turned in the direction of the arrow 1, fig. 4, until the shoulder  $r$  of the arm K is brought into contact with that of the fixed nut; the stop-nut M is then adjusted to such a position upon the screw that the shaft cannot be turned in a contrary direction more than two complete revolutions.

These several adjustments having been made, the first tooth is cut on the edge of the wheel, after which the spindle G is turned, by means of the crank, to the extent of two revolutions, which will be accurately determined by the contact of the shoulder  $s$  of the stop-nut M, with the shoulder  $s'$  of the fixed nut.

A second tooth is then cut on the wheel, and in order to effect the required adjustment of the latter for the cutting of a third tooth the crank is first turned in one direction until the shoulder  $r$  is brought in contact with the shoulder  $r'$ , and then in the reverse direction to the extent permitted by the stop-nut.

This operation is continued in the same manner until the full number of teeth has been cut, the divisions being made entirely around the wheel with the most perfect accuracy.

In order to cut a wheel of eighteen teeth it would be only necessary to adjust the stop-nut to such a position as to permit four revolutions of the shaft instead of two; and to cut a pinion of nine teeth the shaft should be permitted to make eight complete revolutions in order to effect each adjustment of the wheel.

The machine, however, is not confined in its operations to the cutting of wheels having such number of teeth only as will divide equally into the number of teeth of the worm-wheel.

Suppose, for instance, that a wheel of twenty-eight teeth has to be cut. This number divided into seventy-two (the number of teeth in the worm-wheel) gives two and sixteen-twenty-eighths, or two and eight-fourteenths, as the number of revolutions of the shaft G for each adjustment of the wheel.

The stop-nut M is first adjusted, as before described, so as to permit two revolutions of the shaft, and the fraction is determined by means of the ratch-

et-wheel, which, in the present instance, has fourteen teeth.

The stop-nut M being adjusted to permit two revolutions, and the shoulder  $r$  and  $r'$  in contact with each other, the said nut is held with one hand to prevent it from turning with the screw, while with the other hand the crank L is turned in such a direction as to withdraw the shoulder  $r$  from the shoulder  $r'$ , and cause the point of the pawl to slip over eight of the teeth of the stationary ratchet-wheel, or in other words to pass around eight-fourteenths of the circumference of the latter.

If, after this, the nut M be tightened by means of the jam-nut, and the shoulders  $r$  and  $r'$  be again brought in contact, it will be found that the nut M has been adjusted to such a position as to permit two and eight-fourteenths revolutions of the shaft for every adjustment of the wheel.

Other fractions can in like manner be determined, it being proposed to furnish the machine with a number of ratchet-wheels having different numbers of teeth, so that any required divisions can be made.

The object of extending the sleeve H through the screw J is to connect the ratchet I to the screw, so that it will move longitudinally with the latter but revolve independently of the same; other means of thus connecting the screw and ratchet may, however, be employed. For instance, the sleeve may be dispensed with, and the ratchet may have at its inner side fingers extending into an annular groove in the screw, or clasping a flange on the latter, so that, while the ratchet will always move longitudinally with the screw, it may revolve without turning the same.

Other devices may also be substituted for the pawl and ratchet as, for instance, an eccentric-dog arranged upon a lug or arm on the screw; or such devices may be altogether dispensed with, and the screw turned by grasping a flange on the same with the fingers.

It will be evident, without further description, that by the use of the above simple mechanism wheels of any number of teeth can be cut as accurately as in machines furnished with the well-known complex and costly dividing-plate.

#### Claim.

The combination of the worm G, its shaft  $f$ , screw J turning in a nut,  $J'$ , and sliding on the shaft G, the stationary stops  $r'$   $s'$ , fixed stop  $r$ , and adjustable stop  $s$  on the screw, and the sleeve H, wheel I, arm and pawl, or equivalent devices, whereby the screw may be turned in one direction with and in the other independently of the shaft  $f$ , as specified.

In testimony whereof I have signed my name to this specification in the presence of two subscribing witnesses.

C. VAN HAAGEN.

Witnesses:

WM. A. STEEL,  
HARRY SMITH.