

(12) STANDARD PATENT APPLICATION (11) Application No. AU 2018274903 A1
(19) AUSTRALIAN PATENT OFFICE

(54) Title
Methods and apparatus for flow restoration

(51) International Patent Classification(s)
A61B 17/22 (2006.01) **A61F 2/92** (2006.01)
A61F 2/90 (2006.01)

(21) Application No: **2018274903** (22) Date of Filing: **2018.12.05**

(43) Publication Date: **2019.01.03**

(43) Publication Journal Date: **2019.01.03**

(62) Divisional of:
2016277687

(71) Applicant(s)
Covidien LP

(72) Inventor(s)
FRANCO, David;SLEE, Earl Howard;WILDER III, Thomas;SHRIVASTAVA, Sanjay;MCCARTHY, Thomas;ASHBY, Mark Philip

(74) Agent / Attorney
Spruson & Ferguson, GPO Box 3898, Sydney, NSW, 2001, AU

METHODS AND APPARATUS FOR FLOW RESTORATION

ABSTRACT

A removable, integrated apparatus-thrombus mass, comprising a thrombus (12) at least partially engaged with an apparatus, wherein the apparatus comprises: a self-expandable structure (5) comprising a first plurality of cells, the structure (5) having a proximal end (3) and a distal end (2), the proximal end (3) and the distal end (2) being open, and the first plurality of cells being expanded into and engaged with at least a portion of the thrombus (12); a tapering portion comprising a second plurality of cells, the tapering portion disposed toward the proximal end of the structure (5); and a connection portion, at which the tapering portion converges, located at a proximal end of the tapering portion; wherein the apparatus is self-expandable and pre-formed to assume a volume-enlarged form and, in the volume-enlarged form, takes the form of a longitudinally open tube tapering toward the connection portion.

METHODS AND APPARATUS FOR FLOW RESTORATION

CROSS-REFERENCE TO RELATED APPLICATION

This is a divisional application of Australian Patent Application No. 2016277687, filed on 22 December 2016. The entire content of Australian Patent Application No. 2016277687 is hereby incorporated by reference in its entirety and for all purposes.

FIELD OF THE INVENTION

The present invention relates to methods and apparatus for quickly or immediately restoring blood flow in occluded blood vessels, particularly occluded cerebral arteries. Furthermore, the present invention relates to the application of such apparatus for thrombus removal and/or thrombus dissolution.

BACKGROUND OF THE INVENTION

Current technology for treating cerebral arteries occluded by thrombus may take hours to reestablish flow in the artery. Furthermore, known apparatus and methods for treating cerebral thrombus may be ineffective or only partially effective at resolving thrombus, and may additionally result in distal embolization or embolization of uninvolved arteries. The risk and degree of permanent neurological deficit increases rapidly with increased time from onset of symptoms to blood flow restoration.

OBJECT OF THE INVENTION

It is an object of the present invention to substantially overcome or at least ameliorate one or more of the disadvantages of the prior art, or to at least provide a useful alternative.

SUMMARY OF THE INVENTION

Accordingly, in one aspect of the present invention there is provided a removable, integrated apparatus-thrombus mass, comprising a thrombus at least partially engaged with an apparatus, wherein the apparatus comprises:

a self-expandable structure comprising a first plurality of cells, the structure having a proximal end and a distal end, the proximal end and the distal end being open, and the first plurality of cells being expanded into and engaged with at least a portion of the thrombus;

a tapering portion comprising a second plurality of cells, the tapering portion disposed toward the proximal end of the structure; and

a connection portion, at which the tapering portion converges, located at a proximal end of the tapering portion;

wherein the apparatus is self-expandable and pre-formed to assume a volume-enlarged form and, in the volume-enlarged form, takes the form of a longitudinally open tube tapering toward the connection portion.

Another aspect of the present invention provides a removable, integrated apparatus-thrombus mass, comprising a thrombus at least partially engaged with a self-expandable apparatus, wherein the apparatus comprises:

a self-expandable structure comprising a first plurality of cells, the structure having a proximal end and a distal end, the proximal end and the distal end being open, and the first plurality of cells being expanded into and interlocked with at least a portion of the thrombus;

a tapering portion comprising a second plurality of cells, the tapering portion disposed toward the proximal end of the structure; and

a connection member, toward which the tapering portion converges, located at a proximal end of the tapering portion;

wherein the self-expandable apparatus is configured to assume a volume-enlarged form and, in the volume-enlarged form, to take the form of a longitudinally open tube; and

wherein the thrombus extends outside of the structure.

There is also disclosed herein a removable, integrated apparatus-thrombus mass, comprising a thrombus at least partially engaged with an apparatus, wherein the apparatus comprises:

a structure comprising a first plurality of cells, the structure having a proximal end and a distal end, the proximal end and the distal end being open, and the first plurality of cells being configured to engage at least a portion of the thrombus;

a tapering portion comprising a second plurality of cells, the tapering portion disposed toward the proximal end of the structure; and

a connection portion, at which the tapering portion converges, located at a proximal end of the tapering portion;

wherein the apparatus is self-expandable and pre-formed to assume a volume-enlarged form and, in the volume-enlarged form, takes the form of a longitudinally open tube tapering toward the connection portion.

There is also disclosed herein a removable, integrated apparatus-thrombus mass, comprising a thrombus at least partially engaged with a self-expandable apparatus, wherein the apparatus comprises:

a structure comprising a first plurality of cells, the structure having a proximal end and a distal end, the proximal end and the distal end being open, and the first plurality of cells being configured to interlock with at least a portion of the thrombus;

a tapering portion comprising a second plurality of cells, the tapering portion disposed toward the proximal end of the structure; and

a connection member, toward which the tapering portion converges, located at a proximal end of the tapering portion;

wherein the self-expandable apparatus is configured to assume a volume-enlarged form and, in the volume-enlarged form, to take the form of a longitudinally open tube; and

wherein the thrombus extends outside of the structure.

There is also disclosed herein a removable, integrated apparatus-thrombus mass, comprising a thrombus at least partially engaged with an apparatus, wherein the apparatus comprises:

a structure comprising a first plurality of cells, the structure having a proximal end and a distal end, the proximal end and the distal end being open, and the first plurality of cells being configured to engage at least a portion of the thrombus;

a tapering portion comprising a second plurality of cells, the tapering portion disposed toward the proximal end of the structure; and

a connection portion, at which the tapering portion converges, located at a proximal end of the tapering portion;

wherein the apparatus is self-expandable and pre-formed to assume a volume-enlarged form and, in the volume-enlarged form, takes the form of a longitudinally open tube tapering toward the connection portion.

There is also disclosed herein a thrombus at least partially engaged with a self-expandable apparatus, wherein the apparatus comprises:

a structure comprising a first plurality of cells, the structure having a proximal end and a distal end, the proximal end and the distal end being open, and the first plurality of cells being configured to interlock with at least a portion of the thrombus that extends outside of the structure;

a tapering portion comprising a second plurality of cells, the tapering portion disposed toward the proximal end of the structure; and

a connection member, toward which the tapering portion converges, located at a proximal end of the tapering portion;

wherein the self-expandable apparatus is configured to assume a volume-enlarged form and, in the volume-enlarged form, to take the form of a longitudinally open tube.

There is also disclosed herein an apparatus for removal of a thrombus in a cerebral blood vessel and for restoring localized blood flow in the cerebral blood vessel, comprising:

a self-expandable distal member comprising a tubular structure having a plurality of cells, the tubular structure being configured to assume a volume-enlarged configuration at a site of the thrombus in the cerebral blood vessel, and to be modified into a compressed configuration for delivery through a microcatheter, the compressed configuration having a smaller cross-sectional dimension than the volume-enlarged configuration, the tubular structure being configured to expand into the thrombus when transitioning from the compressed configuration to the volume-enlarged configuration upon proximal withdrawal of the microcatheter from over the tubular structure, the tubular structure having a proximal end and a distal end, said distal end of the tubular structure being configured such that at least an outer portion of the tubular structure engages and applies an outward radial force on at least a portion of the thrombus, whereby the tubular structure interlocks with at least a portion of the thrombus;

a proximal elongate member attached to the self-expandable distal member by a plurality of struts such that the proximal elongate member extends generally parallel to, and is offset from, a central longitudinal axis of the tubular structure.

In one embodiment, methods and apparatus are provided to create immediate (or restore) blood flow in the occluded artery upon deployment of the apparatus. In one embodiment, a self-expandable apparatus is delivered to a site that is radially adjacent to the thrombus and the apparatus is expanded thereby restoring flow.

In another embodiment, the invention is directed to methods and apparatus that restore blood flow in the blood vessel that is occluded with a thrombus, with an associated increased

efficiency in dislodging the thrombus from the vessel and removing the thrombus. In this embodiment, a self-expandable apparatus is delivered to a site that is radially adjacent to the thrombus and then expanded. The expanded apparatus then restores flow, which flow assists in dislodging the thrombus from the vessel wall. In one embodiment, the apparatus engages the thrombus and the thrombus can then be removed from the site of occlusion.

In yet another embodiment, the invention is directed to methods and apparatus that restore blood flow in the occluded artery, with an associated increased efficiency in dissolving part or all of the thrombus from the vessel and optionally retrieval of the apparatus. In this embodiment, a self-expandable apparatus is delivered to a site that is radially adjacent to the thrombus and then expanded. Once expanded, the apparatus then restores flow to the occluded site and this increased flow may dissolve or partially or substantially dissolve the thrombus and the apparatus-thrombus mass is then removed from the formerly occluded site.

In still yet another embodiment, the invention is directed to methods and apparatus that restore blood flow in the occluded artery, with an associated increased efficiency in dissolving part or all of the thrombus from the vessel and implantation of a portion of the apparatus. In this embodiment, the apparatus engages (or implants in or integrates with) at least a portion of the thrombus providing a removable, integrated apparatus-thrombus mass. The removable, integrated apparatus-thrombus is removed from the site of occlusion.

In some embodiments, the method of the invention is directed to a method for imaging restoration of blood flow in a blood vessel occluded with a thrombus. This method comprises: a) acquiring an image of a self-expandable apparatus placed radially adjacent to a thrombus; and b) acquiring an image of expanding the apparatus thereby restoring blood flow.

In another embodiment, the method of the invention is directed to a method for imaging partially or substantially dissolving a thrombus lodged in a blood vessel. This method comprises: a) acquiring an image of a self-expandable apparatus placed radially adjacent to a thrombus; and b) acquiring an image of expanding the apparatus thereby increasing blood through the vessel wherein the increased blood flow partially or substantially dissolves the thrombus.

In still yet another embodiment, the method of invention is directed to a method for imaging dislodging a thrombus lodged in a blood vessel. This method comprises: a) acquiring

an image of a self-expandable apparatus placed radially adjacent to a thrombus; b) acquiring an image of expanding the apparatus thereby engaging at least a portion of the thrombus; and c) acquiring an image of moving the apparatus distally or proximally thereby dislodging the thrombus.

A number of self-expandable apparatus are contemplated to be useful in the methods of the invention. In one embodiment, the apparatus is reversibly self-expandable. In another embodiment, the apparatus is fully retrievable or retractable. In one embodiment, the self-expandable apparatus comprises a mesh structure comprising a first plurality of mesh cells, the mesh structure having a proximal end and a distal end; a tapering portion comprising a second plurality of mesh cells, the tapering portion disposed toward the proximal end of the mesh structure; and a connection point, at which the tapering portion converges, located at a proximal end of the tapering portion, wherein the apparatus is preformed to assume a volume-enlarged form and, in the volume-enlarged form, takes the form of a longitudinally open tube tapering toward the connection point.

Another embodiment of the invention is a self-expandable apparatus for removal of a thrombus in a blood vessel, comprising: a mesh structure comprising a first plurality of mesh cells, the mesh structure having a proximal end and a distal end wherein said distal end of the mesh structure is configured to engage at least a portion of the thrombus to form a removable, integrated apparatus-thrombus mass; a tapering portion comprising a second plurality of mesh cells, the tapering portion disposed toward the proximal end of the mesh structure; and a connection point, at which the tapering portion converges, located at a proximal end of the tapering portion, wherein the apparatus is pre-formed to assume a volume-enlarged form and, in the volume-enlarged form, takes the form of a longitudinally open tube tapering toward the connection point.

It is contemplated that the distal end of the mesh structure is configured to assist in thrombus retrieval by providing increasing support to the mesh structure and by increasing thrombus retention.

In another embodiment of the invention is provided a removable, integrated apparatus-thrombus mass, comprising a thrombus at least partially engaged with an apparatus, wherein the apparatus comprises a mesh structure comprising a first plurality of mesh cells, the mesh structure having a proximal end and a distal end wherein said distal end of the mesh structure is

configured to engage at least a portion of the thrombus; a tapering portion comprising a second plurality of mesh cells, the tapering portion disposed toward the proximal end of the mesh structure; and a connection point, at which the tapering portion converges, located at a proximal end of the tapering portion, wherein the apparatus is pre-formed to assume a volume-enlarged form and, in the volume-enlarged form, takes the form of a longitudinally open tube tapering toward the connection point.

BRIEF DESCRIPTION OF THE DRAWINGS

The accompanying drawings, which are incorporated herein and constitute part of this specification, illustrate exemplary embodiments of the invention, and, together with the general description given above and the detailed description given below, serve to explain the features of the invention.

Fig. 1 shows an apparatus useful for the methods of the present invention.

Fig. 2a shows a target occlusion or thrombus to be treated by the present invention.

Figs. 2b, 3, and 4 show placement methods according to the present invention. Fig. 3 is shown with the microcatheter 8 in phantom.

Fig. 5 shows thrombus dislodgement and mobilization according to the present invention.

Figs. 6 and 7 show thrombus dissolution methods according to the present invention.

Figs. 8 and 9 show apparatus retrieval methods according to the present invention, with the microcatheter shown in phantom.

Figs. 10, 11, and 12 show apparatus implantation methods according to the present invention.

Fig. 13 is an apparatus according to one embodiment of the present invention having a honeycomb structure.

Fig. 14 is another embodiment of a stent according to the present invention having a honeycomb structure.

Fig. 15 is a third embodiment of a stent according to the present invention having a honeycomb structure.

Fig. 16 is a warp-knitted structure as can be used for an apparatus according to the invention.

Fig. 17a and Fig. 17b is a schematic representation of an apparatus according to an embodiment of the present invention shown in its superimposed and in its volume-reduced shape.

Fig. 18a, Fig. 18b, Fig. 18c, Fig. 18d, and Fig. 18e are embodiments, including marker elements, that can be employed in the most distal segment of the apparatus according to the present invention.

Fig. 19a and Fig. 19b are schematic representations of two detachment locations by which the apparatus, according to the present invention, can be detachably linked to a guide wire.

DETAILED DESCRIPTION OF THE INVENTION

Unless defined otherwise, all technical and scientific terms used herein have the same meanings as commonly understood by one of ordinary skill in the art to which this invention belongs. Although any methods and materials similar or equivalent to those described herein can be used in the practice or testing of the present invention, the preferred methods, devices, and materials are now described. All publications and patent applications cited herein are incorporated herein by reference in their entirety. Nothing herein is to be

construed as an admission that the invention is not entitled to antedate such disclosure by virtue of prior invention.

It must be noted that as used herein and in the appended claims, the singular forms "a," "an," and "the" include plural references unless the context clearly dictates otherwise.

Methods

The invention is directed to methods of restoring localized flow to an occluded vascular site. The vascular site, or blood vessel, can be occluded by a thrombus. The apparatus employed in the methods of the invention may be positioned at the vascular site with a microcatheter and optionally a guide catheter. The methods of the invention may employ a fully retrievable apparatus which is an improvement over the art which methods required the apparatus to be implanted permanently into the patient. When the apparatus is permanently placed in the patient, lifelong anticoagulant therapy for the patient is required. Therefore, it is contemplated that by using a retrievable apparatus, lifelong anticoagulant therapy may be avoided.

Methods and apparatus are provided to restore blood flow in cerebral arteries 11 occluded with thrombus 12 (Fig. 2a). Such methods utilize an apparatus having a self-expandable, optionally reversibly self-expandable, distal segment 1 including distal end 2, proximal end 3, and body portion 4 that is pre-formed to assume a superimposed structure 5 in an unconstrained condition but can be made to take on a volume-reduced form 6 making it possible to introduce it with a push wire 7 attached at the proximal end 3 and a microcatheter 8, with the distal segment 1 in its superimposed structure 5 assuming the form of a longitudinally open tube and having a mesh structure of interconnected strings or filaments or struts (Fig. 1 and 3). In one embodiment, the distal segment 1 has a tapering structure at its proximal end 3 where the strings or filaments or struts converge at a connection point 9. The push wire 7 is preferably attached at or adjacent to the connection point 9. Such attachment 10 may be permanent or a releasable mechanism. The methods disclosed herein can be performed with the medical distal segment 1 (or apparatus or stent, of which all terms are used interchangeably) described in U.S. Patent 7,300,458, which is incorporated herein in its entirety.

According to the present invention, the self-expandable distal segment 1 of the apparatus is positioned within a blood vessel 11 occluded by thrombus 12 in a volume-reduced form 6 by advancing it with the push wire 7 within a microcatheter 8 such that its proximal end 3 is upstream of the thrombus and its distal end 2 is downstream of the thrombus and the body portion 4 is located radially adjacent to the thrombus 12 (Figs. 1 and 3). As shown in Fig. 3, the distal end 2 of the distal segment 1 is positioned distal to the distal thrombus boundary and the proximal end 3 of the distal segment is positioned proximal of the proximal thrombus boundary. The distal segment 1 is held in a fixed position by holding the push wire 7 stationary while the distal segment 1 is released from its volume-reduced form 6 by withdrawing the microcatheter 8 proximally of the distal segment 1 (Fig. 4). The distal segment 1 assumes at least a portion of its superimposed structure 5 in its unconstrained condition 13 thereby expanding to bring at least part of the body portion into penetrating contact with the thrombus 12', exerting an outward radial force on the thrombus 12', reducing the cross-sectional area of the thrombus 12', and immediately re-establishing blood flow 14 through the blood vessel 11 past the thrombus 12'.

Also contemplated by this invention is administration of an effective amount of a clot-busting drug, such as, for example tissue plasminogen activator (tPA), to the site of the thrombus. Administration of this drug will act to further enhance dissolution of the clot.

This placement methodology expands the population of patients eligible for treatment over apparatus that require intravascular space distal to the reach of a microcatheter as the methodology of this invention places the distal segment 1 beyond the distal end of the thrombus 12. Additionally, this placement methodology expands the population of physicians that can successfully practice the method, as it is delivered with microcatheter technology already familiar to the user, and facilitates rapid placement of the apparatus. Immediately restoring blood flow 14 is a significant advantage over known apparatus and methods for treating cerebral arteries 11 occluded by thrombus 12 because known apparatus and methods may take hours to re-establish flow 14, and it is well established that the risk and degree of permanent neurological deficit increases rapidly with increased time from onset of symptoms to blood flow restoration.

In one embodiment thrombus removal methods and apparatus are provided that restore blood flow 14 in the occluded artery 11, with an increased efficiency in dislodging the thrombus 12' from the vessel coupled with removal of the thrombus 12' and apparatus from the patient. In a preferred embodiment, restoring blood flow 14 in the occluded artery 11 involves placing a microcatheter 8 such that the distal tip 16 of the microcatheter is beyond the distal end of the thrombus 12, wherein the distal tip 16 is from greater than about 0 millimeter (mm) to about 10 mm or more, or about 3 mm to about 5 mm (Fig. 2b) beyond the distal end of the thrombus 12. The self-expandable distal segment 1 is advanced within the microcatheter 8 in its reduced volume form 6 by the push wire 7 until its distal end 2 is just beyond the distal end of the thrombus 12 (Fig. 3).

Visualization of proper placement may be done by fluoroscopy. Specifically, this may be accomplished by aligning radiopaque markers 15 on the distal end of the distal segment with a distal radiopaque microcatheter marker 17 (Fig. 3). As mentioned above, this invention is also directed to various methods of acquiring images of the process. The method of imaging typically employed is fluoroscopy (which can confirm proper placement of the apparatus) or contrast injection (which can confirm blood flow restoration). However, a number of imaging methods known by those of skill in the art are also contemplated.

The distal segment 1 is then deployed within and across the thrombus 12' by holding the push wire 7 fixed while withdrawing the microcatheter 8 proximally until the distal segment 1 is released 13 (Fig. 4). One indication of full deployment is the visualization by the clinician that a radiopaque marker 18 defining the proximal end 3 of the distal segment 1 is aligned with, or distal of, the distal radiopaque microcatheter marker 17. Alternatively, the microcatheter 8 can be completely removed from the patient. Immediately upon distal segment 1 deployment 13, blood flow 14 is restored across the thrombus 12' and confirmation can be visualized via contrast injection. This is an indication of proper distal segment position relative to the thrombus 12' and vascular anatomy.

The apparatus can be used to remove the thrombus 12' after one of the following: a fixed amount of time has elapsed after deployment 13 of the distal segment 1, which may be from about 0 minutes to about 120 minutes or more; blood flow 14 across the thrombus 12'

is observed to stop; a predetermined maximum amount of flow time has elapsed, whichever occurs first.

Removing the thrombus 12' may be accomplished by any number of variations (Fig. 5). For example, as the distal tip of volume-reduced form 6 is moved beyond the thrombus, it will encounter less resistance to expansion and provide a greater radial force as compared to that portion engaging the thrombus as shown in Fig. 5. Thus distal tip 2 may expand beyond the thrombus 12' creating a distal tip 2 having a larger diameter than the diameter of the distal segment that is engaged by at least a portion of the thrombus. In some embodiments, this can be a hook-like distal configuration. Further structural modifications are described below that could be used to further aid in thrombus engagement and removal. Using the push wire 7, a pull force 19 of the deployed distal segment 13 will retract the thrombus back to the catheter as the hook-like configuration acts to snag the thrombus. Subsequent removal of the catheter will result in removal of the thrombus from the site of occlusion.

Prior to pulling the apparatus back, the microcatheter 8 can be manipulated in any of the following ways: the distal radiopaque microcatheter marker 17 can be left at or proximal to distal segment proximal radiopaque marker 18 or completely removed from patient; microcatheter 8 can be moved forward to a predetermined point relative to the distal segment 1, which may be: when the distal radiopaque microcatheter marker 17 is desirably aligned with the distal segment of proximal radiopaque marker 18; when the distal radiopaque microcatheter marker 17 is desirably aligned distal of the distal segment of proximal radiopaque marker 18, for example about 0.5 mm to about 10 mm or about 5 mm to about 10 mm; when significant resistance to microcatheter 8 advancement is encountered as evidenced by buckling of the microcatheter 8; or whichever of desired-alignment or significant resistance occurs first. While moving the deployed distal segment 13 toward or into the guide catheter, any of the following may occur: proximal guide lumen communicates with pressure bag or other positive pressure fluid source; proximal guide lumen communicates with atmosphere; or proximal guide lumen communicates with aspiration source or other negative pressure.

Thrombus removal methods of the present invention have unique advantages over known thrombus removal methods. When deployed across a thrombus, the distal segment 1 creates intra-procedural flow 14 by creating a fluid path across the thrombus 12' (Fig. 4). In this way, the distal segment 13 significantly reduces the pressure drop across the thrombus 12', and accordingly significantly reduces the pressure related forces which would otherwise resist removal of the thrombus 12 (Fig. 5). Further, the fluid path is created by the deployed distal segment 13 separating a significant portion of the thrombus 12' circumference away from the vessel wall. In addition, expansion of volume-reduced form 6 creates an integrated mass where the mesh is embedded within the thrombus. As above, the distal portion of volume-reduced form 6 can produce a greater radial force (and may be in a hook-like configuration upon expansion) thereby facilitating removal of the thrombus.

It is estimated that about 10% to about 60% of the original thrombus 12 circumference is separated from the vessel wall after the distal segment 1 is deployed 13, and the ability of the post deployment thrombus 12' to hang onto the vessel wall via adhesion and friction is accordingly reduced. Still further, the cross sectional area of the original thrombus 12 is significantly reduced by the deployed distal segment 13, resulting in a thrombus 12' having about 30% to about 95% of its original cross sectional area, but more typically about 50% to about 80% of its original cross sectional area. All of this results in a more effective revascularization procedure as a result of lower thrombus dislodgement and mobilization force and more effective thrombus mobilization 19, as demonstrated by the functions later described herein. Of further benefit, the lower thrombus mobilization force is distributed along the entire length of the thrombus 12', or at least along the entire length of the distal segment 13, reducing the chances of the apparatus slipping past or through the thrombus or fragmenting the thrombus, which could result in residual thrombus, distal embolization, or embolization of uninvolved territories.

A target occlusion is represented by an original thrombus 12 having cross sectional area A (Fig. 2a), creating an associated pressure drop across the thrombus of P , having circumferential vessel contact area C , and f is a quantity proportional to a ratio of the thrombus adhesive and frictional forces/contact area. The force required to dislodge or mobilize this thrombus by known methods that do not establish intra-procedural flow across

the thrombus and do not separate a significant portion of the thrombus circumference away from the vessel wall can be described by the function:

$$(A * P) + C * f$$

For the thrombus removal methods of the present invention, that is when the distal segment 1 is deployed 13 within the thrombus 12' (Fig. 4), the thrombus 12' has reduced cross sectional area "a" where $a < A$, reduced pressure drop across the thrombus "p" where $p < P$, significantly reduced circumferential vessel contact area "c" where $c < C$, and f is a quantity proportional to a ratio of the thrombus adhesive and frictional forces/contact area. The force required to dislodge and mobilize the thrombus 12' according to the methods described herein will be significantly lower than forces required to dislodge and mobilized original thrombus 12 by known methods (Fig. 5), and can be described by the function:

$$(a * p) + c * f$$

Also contemplated by the present invention are thrombus dissolution methods and apparatus that restore blood flow 14 in the occluded artery, with an increased efficiency in dissolving part (Fig. 7) or all (Fig. 6) of the thrombus from the vessel and retrieval of the apparatus (Figs. 8 and 9). As previously described, the distal segment is deployed within and across a thrombus 12' to restore blood flow 14 in the occluded artery (Fig. 4). Immediately reestablishing blood flow 14 is a significant advantage over known apparatus and methods for treating cerebral arteries occluded by thrombus because known apparatus and methods may take hours to reestablish flow. Specific benefits include reestablishing antegrade flow distal of the original occlusion to perfuse ischemic tissue and help break up emboli that may be present distal of the original occlusion. Additional benefit is derived from increasing the surface area of the thrombus 12' exposed to the blood flow, thereby improving the effectivity of natural lysing action of the blood on the thrombus 12' and improving the effectivity of the thrombolytic, anti-coagulant, anti-platelet, or other pharmacological agents introduced by the physician, all of which facilitates thrombus dissolution. When the thrombus has been completely dissolved (Fig. 6), or sufficiently reduced 12'' such that reocclusion is not likely (Fig. 7), the distal segment 1 is retrieved 20 by advancing the microcatheter 8 over the entire distal segment 1 while holding the push wire 7 in a fixed position such that the distal segment 1 is not moved axially within the

artery (Figs. 8 and 9). The apparatus may then be removed through the microcatheter 8 or alternatively the microcatheter 8 can be removed with the distal segment 1 of the apparatus still inside of it.

Additionally, it is contemplated that the methods of the present invention can restore blood flow in the occluded artery, with an increased efficiency in dissolving part or all of the thrombus from the vessel and implantation of the distal segment 1. Methods that include implantation of the distal segment 1 require the use of an apparatus with a releasable attachment mechanism between the distal segment 1 and push wire 7. As previously described, the distal segment 1 is deployed within and across 13 a thrombus 12' to restore blood flow 14 in the occluded artery (Fig. 4). The distal segment 1 can then be released from the push wire via a releasable attachment mechanism. Such release may occur immediately upon reestablishing blood flow (Fig. 10), when the thrombus 12'' has been sufficiently reduced such that reocclusion is not likely (Fig. 11), or when the thrombus is completely dissolved (Fig. 12).

In another embodiment of the invention, the thrombus removal or dissolution is assisted by aspirating the microcatheter and/or the guide catheter.

Utility derived from a releasable mechanism between the distal segment and push wire includes suitability of one apparatus for all of the methods disclosed herein, providing procedural options for the user. Of further benefit, a releasable mechanism enables the user to release the unconstrained distal segment if it is determined that removal from the patient is not possible.

Certain embodiments of the invention include methods of restoring blood flow and then detaching the apparatus and leaving the apparatus *in situ* (Fig. 12). This can be done when it is determined by the clinician that either the apparatus is no longer retrievable. In this embodiment, it is contemplated that the apparatus would be coated or otherwise embedded with anticoagulant or antiplatelet drugs. This is more thoroughly discussed below.

Apparatus

As mentioned above, any suitable self-expandable apparatus may be employed by the methods of the invention. Various embodiments of the apparatus may be found in U.S. Patent 7,300,458, which is incorporated by reference in its entirety.

A distal segment 1, according to Fig. 13, consists of a mesh or honeycomb structure that, in one embodiment, comprises a multitude of filaments interconnected by a laser welding technique. The distal segment 1 can be subdivided into a functional structure A and a tapering proximal structure B, the two structures being distinguishable, *inter alia*, by a different mesh size. To enable the functional structure A to perform its function, its mesh cells 23 are held relatively narrow so that they lend themselves to the implantation into the thrombus 12. In general, the mesh width is in the range of 0.5 to 4 mm and may vary within the segment.

In one aspect of the present invention, the distal segment 1 is a flat or two-dimensional structure that is rolled up to form a longitudinally open object capable of establishing close contact with the wall of the vessel into which it is introduced.

In the tapering proximal structure B of the distal segment 1, there is provided a wider mesh cell 24 structure which has been optimized towards having a minimum expansion effect. In the area of the tapering structure 22, the filaments have a greater thickness and/or width to be able to better transfer to the functional structure A the thrust and tensile forces of the guide wire exerted at a connection point 9 when the distal segment 1 is introduced and placed in position. In the area of the tapering structure it is normally not necessary to provide support for, and coverage of, the vessel wall, but on the other hand requirements as to tensile and thrust strength increase. The filament thickness in the functional structure A generally ranges between 0.02 and 0.076 mm, and in proximal structure part B, the filament thickness is greater than 0.076 mm.

The proximal structure forms an angle from 45 degrees to 120 degrees at the connection point 9, in particular an angle of about 90 degrees. The filament thickness (or string width) is the same as the mesh size and its shape may vary over a great range to suit varying requirements as to stability, flexibility and the like. It is understood that the

proximal structure B, as well, contacts the vessel wall and thus does not interfere with the flow of blood within the vessel.

At a distal end, the filaments 22 end in a series of tails 2 that are of suitable kind to carry platinum markers that facilitate the positioning of the distal segment 1.

The distal segment 1 is curled up in such a way that edges 27 and 28 are at least closely positioned to each other and may overlap in the area of the edges. In this volume-reduced form, the distal segment 1, similar to a wire mesh roll, has curled up to such an extent that the roll so formed can be introduced into a microcatheter and moved within the catheter. Having been released from the microcatheter, the curled-up structure springs open and attempts to assume the superimposed structure previously impressed on it and in doing so closely leans to the inner wall of the vessel to be treated, thus superficially covering a thrombus and then implanting into the thrombus that exists in that location. In this case the extent of the "curl up" is governed by the vessel volume. In narrower vessels a greater overlap of the edges 27 and 28 of the distal segment 1 will occur whereas in wider vessels the overlap will be smaller or even "underlap," will be encountered, and due care must be exercised to make sure the distal segment 1 still exhibits a residual tension.

Suitable materials that can be employed in the device include alloys having shape-memory properties. The finished product is subjected to a tempering treatment at temperatures customarily applied to the material so that the impressed structure is permanently established.

The distal segment 1 has a mesh-like structure consisting of strings or filaments connected with each other. Strings occur if the distal segment 1 comprises cut structures as, for example, are frequently put to use in coronary stents, a mesh-like structure consisting of filaments is found if the distal segment 1 is present in the form of mats having knitted or braided structures or in the form of individual filaments that are welded to one another.

Fig. 14 shows another embodiment of a distal segment 1 according to the invention having the above described honeycomb structure where the tapering proximal structure B is connected with the functional structure part A by additional filaments 29 in a peripheral area 30 as well as in the central area. The additional filaments 29 and 30 bring about a more

uniform transmission of the tensile and thrust forces from the proximal structure B to the functional structure A. As a result, the tensile forces can be better transmitted, especially if the stent might have to be repositioned by having to be retracted into the microcatheter. The additional filaments 29, 30 facilitate the renewed curling up of the stent. Similarly, the transmission of thrust forces occurring when the stent is moved out and placed in position is facilitated so that the stent can be gently applied.

Fig. 15 shows another embodiment of a distal segment 1 according to the invention having a honeycomb structure with the edges 27 and 28 being formed of straight filaments 29. According to this embodiment, the thrust or pressure exerted by the guide wire at the connection point 9 is directly transmitted to the edges 27 and 28 of the functional structure part A which further increases the effect described with reference to Fig. 14.

The embodiment as per Fig. 15, similar to those depicted in Figs. 13 and 14, may be based on a cut foil, i.e., the individual filaments 22, 29 and 30 are substituted by individual strings being the remaining elements of a foil processed with the help of a cutting technique. Laser cutting techniques for the production of stents having a tubular structure are known. The processing of a foil for the production of a pattern suitable for a stent is performed analogously. The impression of the superimposed structure is carried out in the same way as is used for the filament design.

In one embodiment, expanded metal foil may be used with the respective string widths being of the same magnitude. In one embodiment, it is envisioned to subsequently smooth the foil to make sure all strings are arranged on the same plane. The thickness of the foil usually ranges between 0.02 and 0.2 mm. Foils of greater thickness also permit the stent to be used in other fields of application, for example, as coronary stents or in other regions of the body including, for instance, the bile duct or ureter.

Foils worked with the help of a cutting technique are finished by electrochemical means to eliminate burrs and other irregularities to achieve a smooth surface and round edges. One of ordinary skill in the art will understand these electrochemical processes as these processes already are in use in medical technology. In this context, it is to be noted that the stents according to the invention that are based on a two-dimensional geometry and on which a three-dimensional structure is impressed subsequently can be manufactured and

processed more easily than the conventional "tubular" stents that already, during manufacture, have a three-dimensional structure and necessitate sophisticated and costly working processes and equipment.

As pointed out above, the mesh structure of the distal segment 1 according to the invention may consist of a braiding of individual filaments. Such a knitted structure is shown in Fig. 16 where the individual filaments 22 are interwoven in the form of a "single jersey fabric" having individual loops 23 forming a mesh-like structure 31. Single jersey goods of this type are produced in a known manner from a row of needles. The single jersey goods have two fabric sides of different appearance, i.e., the right and left side of the stitches. A single jersey fabric material features minor flexibility in a transverse direction and is very light.

Filaments consisting of a braid of individual strands and formed into a rope can also be employed. Braids comprising twelve to fourteen strands having a total thickness of 0.02 mm can be used. Platinum, platinum alloys, gold and stainless steel can be used as materials for the filaments. Generally speaking, all permanent distal segment 1 materials known in medical technology can be employed that satisfy the relevant requirements.

In one embodiment, it is advantageous to have the fabric rims of such a knitted structure curling up as is known, for example, from the so-called "Fluse" fabric, a German term, which is of benefit with respect to the superimposed structure and application dealt with here. In this case, the superimposed structure can be impressed by means of the knitting process. However, the use of shape-memory alloys in this case as well is feasible and useful.

For the production of such knitted structures, known knitting processes and techniques can be employed. However, since the distal segments according to the invention are of extremely small size--for example, a size of 2 by 1 cm--it has turned out to be beneficial to produce the distal segments in the framework of a conventional warp or weft knitting fabric of textile, non-metallic filaments, for example, in the form of a rim consisting of the respective metallic filaments from which the weft or warp knitting fabric either starts out or that extends from such a fabric. The arrangement of the metallic part of the weft or warp knitting fabric at the rim achieves the aforementioned curling effect. The non-metallic

portions of the knitted fabric are finally removed by incineration, chemical destruction or dissolution using suitable solvents.

Fig. 1 shows a combination of a guide wire 7 with the distal segment 1 attached to it that consists of filaments connected to each other by welding. The distal ends 2 and the connection point 9 where the filaments of the distal segment 1 converge in a tapering structure and that simultaneously represents the joining location with guide wire 7 are shown. The guide wire 7 is introduced into a microcatheter 8 which is of customary make.

Shifting the guide wire 7 within the catheter 8 will cause the distal segment 1 to be pushed out of or drawn into the catheter. Upon the stent being pushed out of the microcatheter 8 the mesh-like structure attempts to assume the superimposed shape impressed on it, and when being drawn in, the mesh structure folds back into the microcatheter 8 adapting to the space available inside.

As a result of the stiffness of its mesh structure, the distal segment 1 can be moved to and fro virtually without restriction via the guide wire 7 until it has been optimally positioned within the vessel system.

As mentioned earlier, customary microcatheters can be used. One advantage of the distal segment 1 according to the invention and of the combination of distal segment 1 and guide wire according to the invention is, however, that after having placed the microcatheter in position with a customary guide wire/marker system, the combination of guide wire 7 and distal segment 1 according to the invention can be introduced into the microcatheter, moved through it towards the implantation site and then moved out and applied in that position. Alternatively, it will be possible to have a second microcatheter of smaller caliber accommodate guide wire 7 and distal segment 1 and with this second microcatheter within the firstly positioned microcatheter shift them to the implantation site. In any case, the distal segment 1 can be easily guided in both directions.

Fig. 17 shows a schematic representation of an distal segment 1 according to the invention in its superimposed or volume-expanded shape and in its volume-reduced shape. In its expanded shape, as illustrated in Fig. 17a, the distal segment 1 forms a ring-shaped structure with slightly overlapping edges 27 and 28. In Fig. 17a the distal segment 1 is

viewed from its proximal end as a top view with the connection point 9 being approximately positioned opposite to the edges 27 and 28. In the combination according to the invention, the guide wire 7 is affixed at the connection point 9.

Fig. 17b shows the same distal segment 1 in its volume-reduced form 6 as it is arranged, for example, in a microcatheter in a curled up condition. In the case illustrated there is a total of two windings of the curled-up distal segment 1 with the connection point 9 being located at the proximal side and the two lateral edges 27 and 28 being the starting and final points of the roll or spiral. The structure is held in its volume-reduced form by the microcatheter 8 and when the distal segment 1 is pushed out of the microcatheter 8 it springs into its expanded shape, as illustrated by Fig. 17a, similar to a spiral spring.

Fig. 18a shows a marker element 15 suitable for the distal segment 1 according to the invention with the marker element 15 being capable of being arranged at the distal end of the distal segment 1. The marker element 15 consists of a lug 33 provided with a small marker plate 35 levelly arranged inside it, i.e., flush with the plane of the distal segment 1 without any projecting elements. The plate 35 is made of an X-ray reflecting material, for example, platinum or platinum-iridium. The marker plate 35 may be connected to the surrounding distal segment 1 structure by known laser welding techniques. As shown in Fig. 18b, the marker elements 15 are arranged at the distal end of the distal segment 1.

As mentioned above, in one embodiment, the apparatus is configured to so as to provide a removable, integrated thrombus apparatus-mass. This configuration can be done in a variety of ways. For example, as can be seen in Fig. 18c, marker element 15' can be provided in a spiral thereby increasing the support of the distal end of the mesh structure and aiding in the thrombus retrieval. Also, as seen in Fig. 18d, the marker element 15'' can be provided as an eyelet shape functioning in a manner similar to the spiral marker 15'. Fig. 18e shows a marker element 15''' shown in the shape of a hook or a peg which can be added to provide additional retention of the thrombus during removal. Marker element 15''' is optionally radiopaque or may be made from the same shape memory alloy as the mesh structure.

Additional structural configurations contemplated to provide a removal, integrated thrombus apparatus-mass include: 1) a greater diameter of the mesh structure in the most

distal location of the distal segment 1 compared to the proximal end of the mesh structure (or a widening-taper on the distal end of the distal segment 1); 2) a third plurality of mesh cells located in the most distally in the distal segment 1, wherein the this third plurality of mesh cells have smaller mesh size compared to the first plurality of mesh cells; 3) adding synthetic polymers or polymeric fibers to the mesh structure; and 4) heating the distal end of the distal segment 1 for a time sufficient to impart increased radial strength for better thrombus retention.

As mentioned above, fibers may be added to the mesh structure. Fibers may be wrapped or wound around the mesh structure. They may have loose ends or may be fully braided throughout the distal segment 1.

Suitable fibers are taught in US Publication 2006/0036281, which is incorporated by reference in its entirety. In certain embodiments, the fibers may be comprised of polymeric materials. The polymeric materials may include materials approved for use as implants in the body or which could be so approved. They may be nonbiodegradable polymers such as polyethylene, polyacrylics, polypropylene, polyvinylchloride, polyamides such as nylon, e.g., Nylon 6.6, polyurethanes, polyvinylpyrrolidone, polyvinyl alcohols, polyvinylacetate, cellulose acetate, polystyrene, polytetrafluoroethylene, polyesters such as polyethylene terephthalate (Dacron), silk, cotton, and the like. In certain specific embodiments the nonbiodegradable materials for the polymer component may comprise polyesters, polyethers, polyamides and polyfluorocarbons.

The polymers can be biodegradable as well. Representative biodegradable polymers include: polyglycolic acid/polylactic acid (PGLA), polycaprolactone (PCL), polyhydroxybutyrate valerate (PHBV), polyorthoester (POE), polyethyleneoxide/polybutylene terephthalate (PEO/PBTP), polylactic acid (PLA), polyglycolic acid (PGA), poly (p-dioxanone), poly (valtolactone), poly (tartronic acid), poly (β malonic acid), poly (propylene fumarate), poly (anhydrides); and tyrosine-based polycarbonates. Additional polymers contemplated include polyglycolide and poly-L-lactide.

Other equivalent materials, including but not limited to stereoisomers of any of the aforementioned, may be used as well.

Figs. 19a and 19b are representations, respectively, of two variations of a separating arrangement by which the distal segment 1 according to the invention is detachably connected to a guide wire 7. In each case, a separating arrangement consists of a dumb-bell shaped element 43 that dissolves under the influence of electrical energy when in contact with an electrolyte. At the proximal (guidewire side) end of the dumb-bell shaped separating element 43, as per Fig. 19a, a spiral structure 45 is located that interacts with a strengthening spiral 46 of the guide wire 7. At the distal end, a ball-shaped element 47 is arranged that, with the help of a laser welding technique, is connected to a platinum spiral 48 which, in turn, is linked with the connection point 9 situated at the proximal end of the distal segment 1. The platinum spiral 48 also serves as an X-ray reflecting proximal marker of the distal segment 1.

To strengthen the joint between the ball-shaped element 47 and the connection point 9, a reinforcement wire 49 may be provided. Alternatively, the platinum spiral 48 may also be designed in such a manner that it withstands the tensile and thrust forces imposed on it.

The separating element 43 can include a steel material that is susceptible to corrosion in an electrolyte under the influence of electrical energy. To accelerate corrosion and shorten the separating time span, a structural or chemical weakening of the dumb-bell shaped element 43 may be beneficial, for example, by applying grinding methods or thermal treatment.

Generally, the portion of the dumb-bell 43 accessible to the electrolyte has a length of 0.1 to 0.5 mm, particularly 0.3 mm.

The spiral structure 45 is secured via welding both to the dumb-bell shaped element 43 and the reinforcement spiral 46 of the guide wire 7. The guide wire 7 itself is slidably accommodated within the microcatheter 8.

Fig. 19b shows a second embodiment that differs from the one described with respect to Fig. 19a, in that the dumb-bell shaped element 43 has a ball-shaped element 47 at each end. The ball shaped elements 47 are connected distally to the connection point 9 of the distal segment 1 and proximally to the guide wire 7 via spirals 48, 46, respectively.

It is of course also provided that other separating principles may be applied, for example, those that are based on mechanical principles or melting off plastic connecting elements.

Coated Apparatus

This invention also contemplates coating the apparatus with anticoagulant and/or an antiplatelet agent or drug. It is contemplated that a drug may be used alone or in combination with another drug.

Anticoagulant agents or anticoagulants are agents that prevent blood clot formation. Examples of anticoagulant agents include, but are not limited to, specific inhibitors of thrombin, factor IXa, factor Xa, factor XI, factor XIa, factor XIIa or factor VIIa, heparin and derivatives, vitamin K antagonists, and anti-tissue factor antibodies, as well as inhibitors of P-selectin and PSGL-1. Examples of specific inhibitors of thrombin include hirudin, bivalirudin (Angiomax®), argatroban, ximelagatran (Exanta®), dabigatran, and lepirudin (Refludan®). Examples of heparin and derivatives include unfractionated heparin (UFH), low molecular weight heparin (LMWH), such as enoxaparin (Lovenox®), dalteparin (Fragmin®), and danaparoid (Orgaran®); and synthetic pentasaccharide, such as fondaparinux (Arixtra®), idraparinux and biotinylated idraparinux. Examples of vitamin K antagonists include warfarin (Coumadin®), phenocoumarol, acenocoumarol (Sintrom®), clorindione, dicumarol, diphenadione, ethyl biscoumacetate, phenprocoumon, phenindione, and tiocloamarol.

Antiplatelet agents or platelet inhibitors are agents that block the formation of blood clots by preventing the aggregation of platelets. There are several classes of antiplatelet agents based on their activities, including, GP IIb/IIIa antagonists, such as abciximab (ReoPro®), eptifibatide (Integrilin®), and tirofiban (Aggrastat®); P2Y₁₂ receptor antagonists, such as clopidogrel (Plavix®), ticlopidine (Ticlid®), cangrelor, ticagrelor, and prasugrel; phosphodiesterase III (PDE III) inhibitors, such as cilostazol (Pletal®), dipyridamole (Persantine®) and Aggrenox® (aspirin/extended-release dipyridamole); thromboxane synthase inhibitors, such as furegrelate, ozagrel, ridogrel and isbogrel; thromboxane A₂ receptor antagonists (TP antagonist), such as ifetroban, ramatroban, terbogrel, (3-{6-[(4-chlorophenylsulfonyl)amino]-2-methyl-5,6,7,8-tetrahydronaphth-1-

yl}propionic acid (also known as Servier S 18886, by de Recherches Internationales Servier, Courbevoie, France); thrombin receptor antagonists, such as SCH530348 (having the chemical name of ethyl (1R,3aR,4aR,6R, 8aR, 9S, 9aS)-9-((E)-2-(5-(3-fluorophenyl)pyridin-2-yl)vinyl)-1-methyl-3-oxododecahydronaphtho[2,3-C] furan-6-ylcarbamate, by Schering Plough Corp., New Jersey, USA, described in US2004/0192753A1 and US2004/0176418A1 and studied in clinical trials, such as A Multicenter, Randomized, Double-Blind, Placebo-Controlled Study to Evaluate the Safety of SCH 530348 in Subjects Undergoing Non-Emergent Percutaneous Coronary Intervention with ClinicalTrials.gov Identifier: NCT00132912); P-selectin inhibitors, such as 2-(4-chlorobenzyl)-3-hydroxy-7,8,9,10-tetrahydrobenzo[H]quinoline-4-carboxylic acid (also known as PSI-697, by Wyeth, New Jersey, USA); and non-steroidal anti-inflammatory drugs (NSAIDS), such as acetylsalicylic acid (Aspirin®), resveratrol, ibuprofen (Advil®, Motrin®), naproxen (Aleve®, Naprosyn®), sulindac (Clinoril®), indomethacin (Indocin®), mefenamate, droxicam, diclofenac (Cataflam®, Voltaren®), sulfinpyrazone (Anturane®), and piroxicam (Feldene®). Among the NSAIDS, acetylsalicylic acid (ASA), resveratrol and piroxicam are preferred. Some NSAIDS inhibit both cyclooxygenase-1 (cox-1) and cyclooxygenase-2 (cox-2), such as aspirin and ibuprofen. Some selectively inhibit cox-1, such as resveratrol, which is a reversible cox-1 inhibitor that only weakly inhibits cox-2.

In one embodiment, a controlled delivery of the drug can control the lytic effect of the drug and treat ischemic stroke and many other vascular diseases. The release rate can be controlled such that about 50% of the drug can be delivered to the thrombus in from about 1 to about 120 minutes. This controlled delivery can be accomplished in one or more of the following ways. First, the drug and polymer mixture may be applied to the stent and the amount of polymer may be increased or the combination may be applied in a thicker layer. Second, the stent may be first coated with polymer, then coated with a layer of drug and polymer, and then a topcoat of polymer can be applied. The release rates of the drug can be altered by adjusting the thickness of each of the layers. Third, the stent can be manufactured to provide reservoirs to hold the drug. In this embodiment, the drug is filled in small reservoirs made on the stent surface. Reservoirs can be made by laser cutting, machine electro-chemical, mechanical or chemical processing.

In the embodiments just described the polymer is biocompatible and biodegradable. These polymers are well known in the art.

Additionally, stents can be coated with a drug-eluting coating such as a combination of a polymer and a pharmaceutical agent. Such coatings can be applied using methods well established in the art, such as dipping, spraying, painting, and brushing. See, U.S. Pat. No. 6,214,115; U.S. Pat. No. 6,153,252; U.S. Patent Application No. 2002/0082679; U.S. Pat. No. 6,306,166; U.S. Pat. No. 6,517,889; U.S. Pat. No. 6,358,556; U.S. Pat. No. 7,318,945; U.S. Pat. No. 7,438,925.

For example, Chudzik et al. (U.S. Pat. No. 6,344,035) teaches a method wherein a pharmaceutical agent or drug is applied in combination with a mixture of polymers such as poly(butyl methacrylate) and poly(ethylene-co-vinyl acetate). Guruwaiya et al. discloses a method for coating a stent wherein a pharmacological agent is applied to a stent in dry, micronized form over a sticky base coating (U.S. Pat. No. 6,251,136). Ding et al. teaches a method of applying drug-release polymer coatings that uses solvents (U.S. Pat. No. 5,980,972) wherein the solutions are applied either sequentially or simultaneously onto the devices by spraying or dipping to form a substantially homogenous composite layer of the polymer and the pharmaceutical agent.

Although various exemplary embodiments of the present invention have been disclosed, it will be apparent to those skilled in the art that changes and modifications can be made which will achieve some of the advantages of the invention without departing from the spirit and scope of the invention. It will be apparent to those reasonably skilled in the art that other components performing the same functions may be suitably substituted.

CLAIMS:

1. A removable, integrated apparatus-thrombus mass, comprising a thrombus at least partially engaged with an apparatus, wherein the apparatus comprises:
 - a self-expandable structure comprising a first plurality of cells, the structure having a proximal end and a distal end, the proximal end and the distal end being open, and the first plurality of cells being expanded into and engaged with at least a portion of the thrombus;
 - a tapering portion comprising a second plurality of cells, the tapering portion disposed toward the proximal end of the structure; and
 - a connection portion, at which the tapering portion converges, located at a proximal end of the tapering portion;wherein the apparatus is self-expandable and pre-formed to assume a volume-enlarged form and, in the volume-enlarged form, takes the form of a longitudinally open tube tapering toward the connection portion.
2. The removable, integrated apparatus-thrombus mass of claim 1, wherein a mesh size of the second plurality of cells is larger than a mesh size of the first plurality of cells.
3. The removable, integrated apparatus-thrombus mass of claim 2, wherein the structure has a distal portion comprising a third plurality of cells distal to the first plurality of cells, the third plurality of cells having a mesh size smaller than the mesh size of the first plurality of cells.
4. The removable, integrated apparatus-thrombus mass of claim 1, wherein the distal end of the structure is heated for a sufficient time to provide increased radial strength.
5. The removable, integrated apparatus-thrombus mass of claim 1, wherein the distal end of the structure comprises fibers.
6. The removable, integrated apparatus-thrombus mass of claim 1, wherein the distal end of the structure comprises one or more pegs and/or hooks.
7. The removable, integrated apparatus-thrombus mass of claim 1, wherein the structure is coated with an anticoagulant or antiplatelet drug.

8. The removable, integrated apparatus-thrombus mass of claim 7, wherein the structure is further coated with a biodegradable, biocompatible polymer to provide for sustained release of the anticoagulant or anti platelet drug.
9. The removable, integrated apparatus-thrombus mass of claim 1, wherein the structure comprises reservoirs to hold an anticoagulant or antiplatelet drug.
10. A removable, integrated apparatus-thrombus mass, comprising a thrombus at least partially engaged with a self-expandable apparatus, wherein the apparatus comprises:
 - a self-expandable structure comprising a first plurality of cells, the structure having a proximal end and a distal end, the proximal end and the distal end being open, and the first plurality of cells being expanded into and interlocked with at least a portion of the thrombus;
 - a tapering portion comprising a second plurality of cells, the tapering portion disposed toward the proximal end of the structure; and
 - a connection member, toward which the tapering portion converges, located at a proximal end of the tapering portion;wherein the self-expandable apparatus is configured to assume a volume-enlarged form and, in the volume-enlarged form, to take the form of a longitudinally open tube; and wherein the thrombus extends outside of the structure.
11. The removable, integrated apparatus-thrombus mass of claim 10, wherein a mesh size of the second plurality of cells is larger than a mesh size of the first plurality of cells.
12. The removable, integrated apparatus-thrombus mass of claim 11, wherein the structure has a distal portion comprising a third plurality of cells distal to the first plurality of cells, the third plurality of cells having a mesh size smaller than the mesh size of the first plurality of cells.
13. The removable, integrated apparatus-thrombus mass of claim 10, wherein the distal end of the structure is heated for a sufficient time to provide increased radial strength.
14. The removable, integrated apparatus-thrombus mass of claim 10, wherein the distal end of the structure comprises fibers.
15. The removable, integrated apparatus-thrombus mass of claim 10, wherein the distal end of the structure comprises one or more pegs and/or hooks.

16. The removable, integrated apparatus-thrombus mass of claim 10, wherein the structure is coated with an anticoagulant or antiplatelet drug.
17. The removable, integrated apparatus-thrombus mass of claim 16, wherein the structure is further coated with a biodegradable, biocompatible polymer to provide for sustained release of the anticoagulant or antiplatelet drug.
18. The removable, integrated apparatus-thrombus mass of claim 10, wherein the structure comprises reservoirs to hold an anticoagulant or antiplatelet drug.
19. The removable, integrated apparatus-thrombus mass of claim 1, wherein the apparatus further comprises a push or guide wire, and wherein the tapering portion is permanently attached to the push or guide wire at or adjacent to the connection portion.
20. The removable, integrated apparatus-thrombus mass of claim 10, wherein the apparatus further comprises a push or guide wire, and wherein the tapering portion is permanently attached to the push or guide wire at or adjacent to the connection member.
21. The removable, integrated apparatus-thrombus mass of claim 1, wherein the apparatus can take a volume-reduced form, and the structure forms edges and is curled up such that the edges overlap in the volume-reduced form.
22. The removable, integrated apparatus-thrombus mass of claim 10, wherein the apparatus can take a volume-reduced form, and the structure forms edges and is curled up such that the edges overlap in the volume-reduced form.
23. The removable, integrated apparatus-thrombus mass of claim 1, further comprising radiopaque markers on the distal end of the structure.
24. The removable, integrated apparatus-thrombus mass of claim 23, wherein the radiopaque markers are attached to distal tails at the distal end of the structure.
25. The removable, integrated apparatus-thrombus mass of claim 10, further comprising radiopaque markers on the distal end of the structure.

26. The removable, integrated apparatus-thrombus mass of claim 25, wherein the radiopaque markers are attached to distal tails at the distal end of the structure.
27. The removable, integrated apparatus-thrombus mass of claim 1, further comprising a radiopaque marker at a proximal end of the tapering portion.
28. The removable, integrated apparatus-thrombus mass of claim 10, further comprising a radiopaque marker at a proximal end of tapering portion.
29. The removable, integrated apparatus-thrombus mass of claim 1, further comprising fibers wrapped or wound around the structure.
30. The removable, integrated apparatus-thrombus mass of claim 10, further comprising fibers wrapped or wound around the structure.

Covidien LP

Patent Attorneys for the Applicant/Nominated Person

SPRUSON & FERGUSON

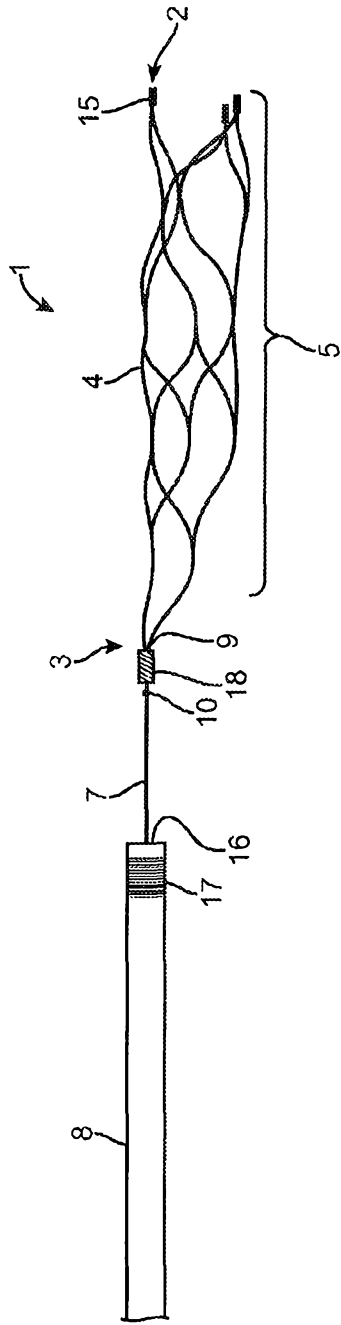

FIG. 1

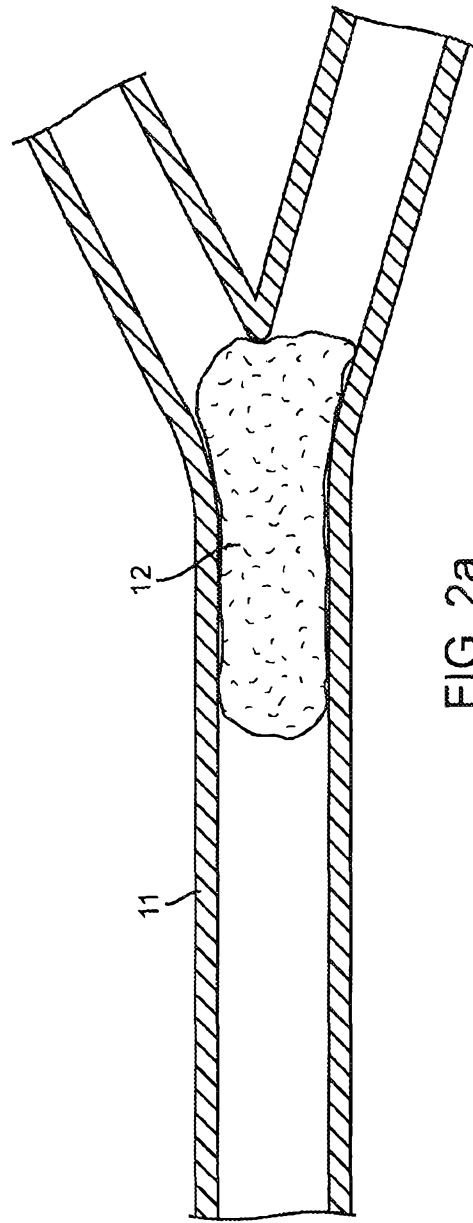

FIG. 2a

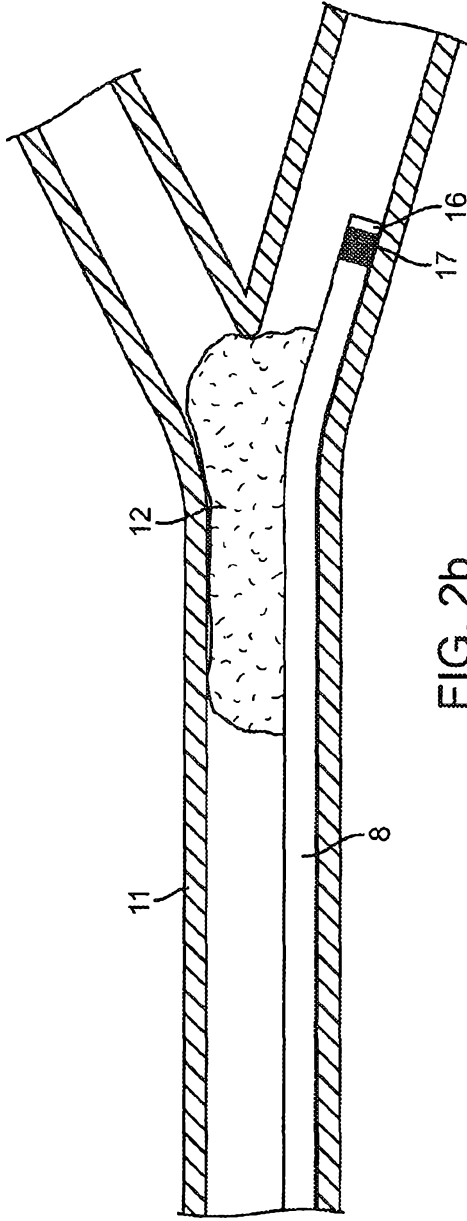

FIG. 2b

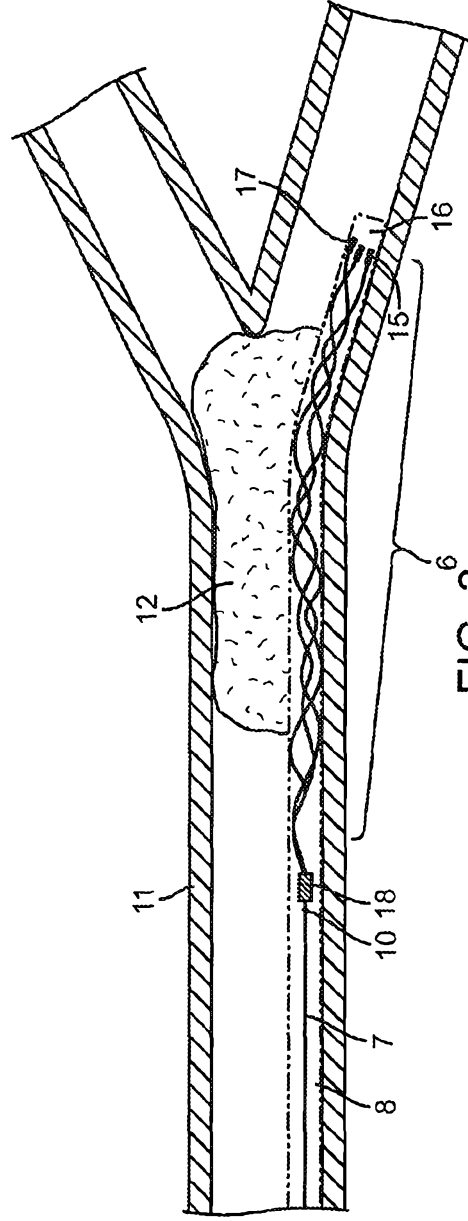

FIG. 3

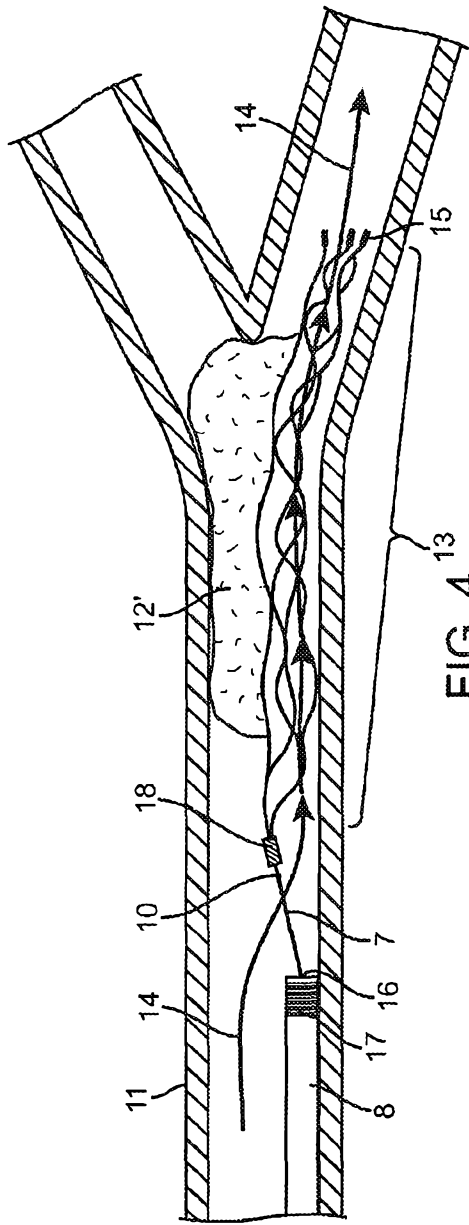

FIG. 4

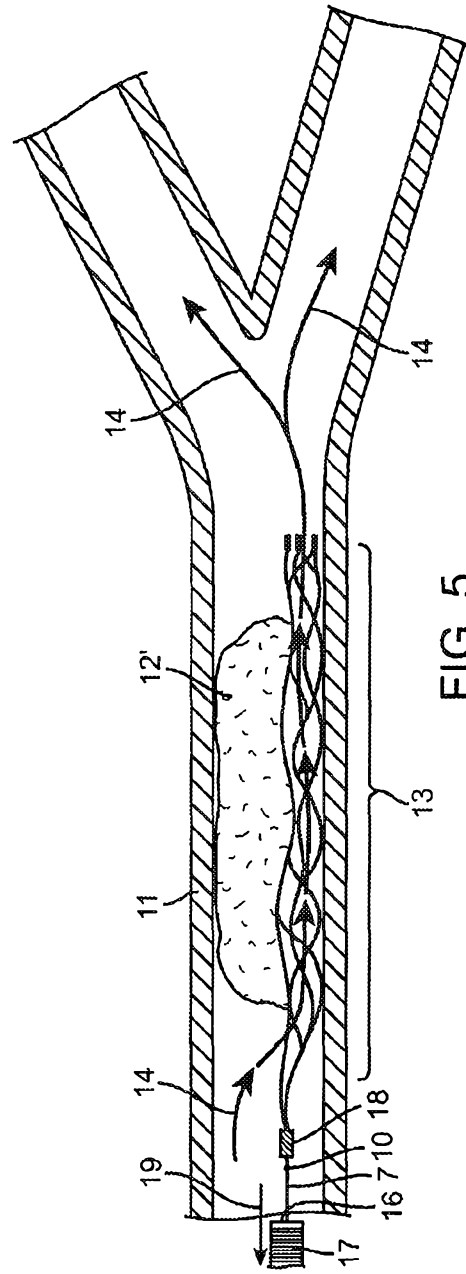

FIG. 5

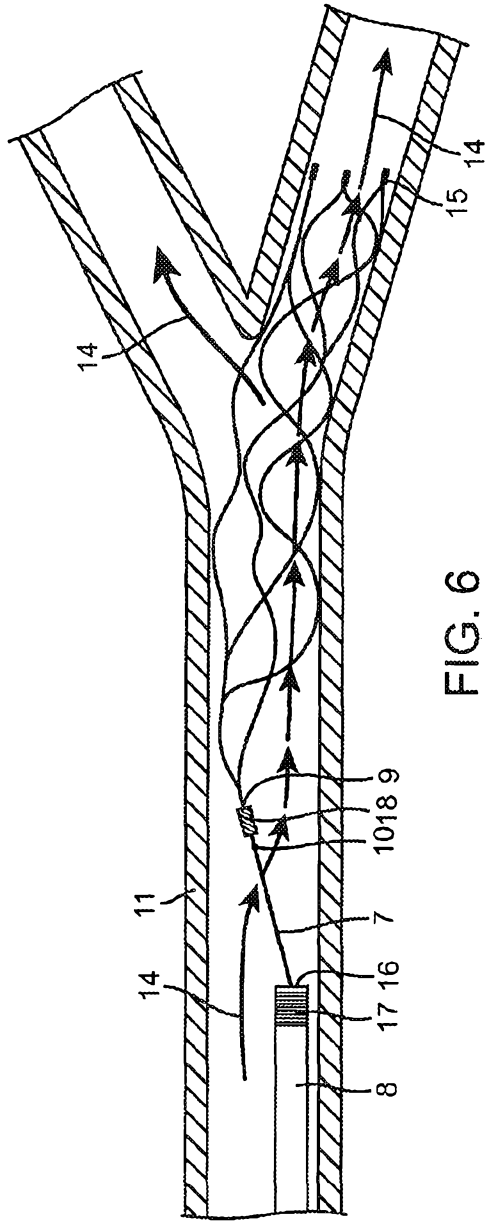

FIG. 6

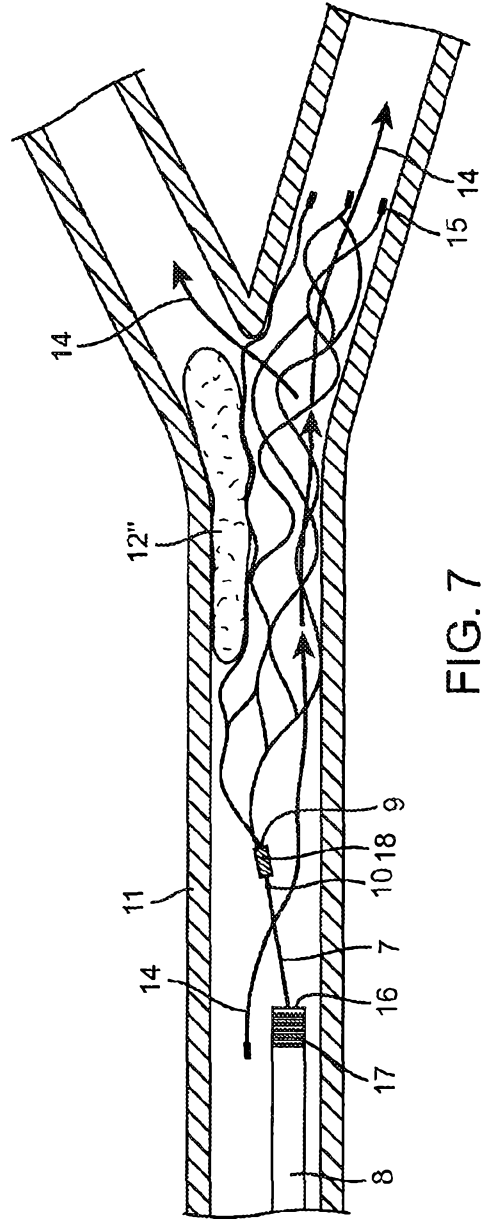

FIG. 7

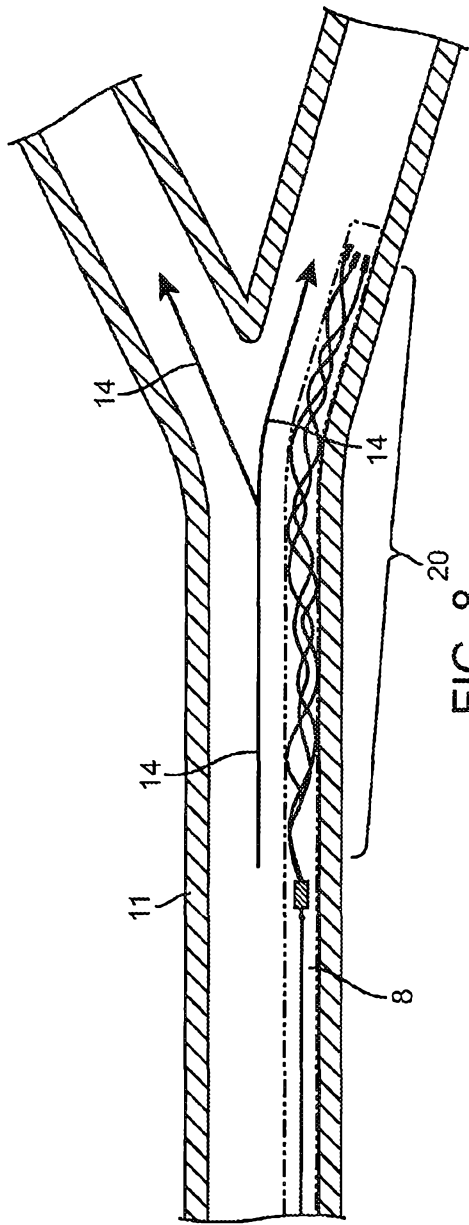

FIG. 8

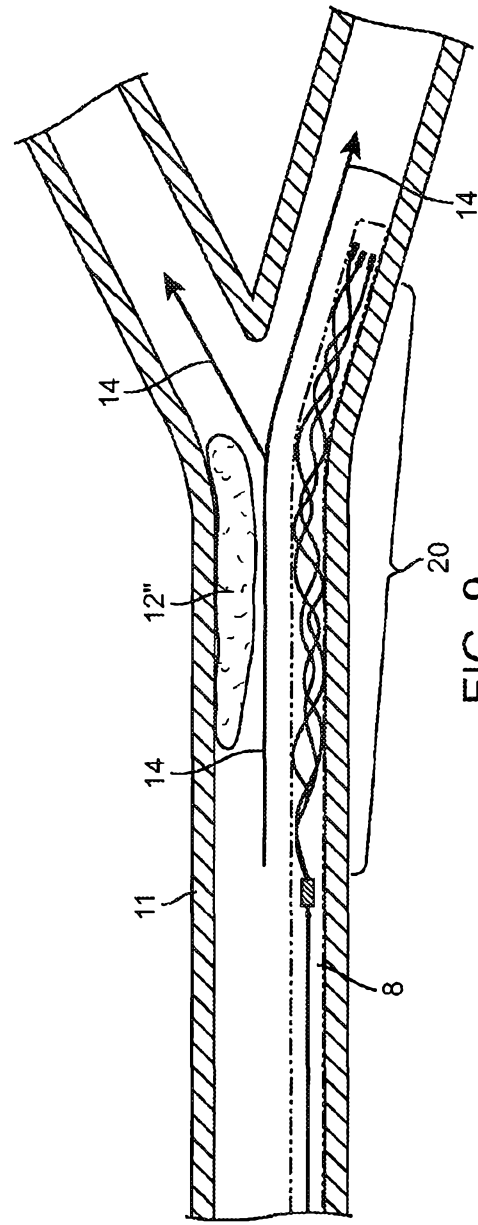

FIG. 9

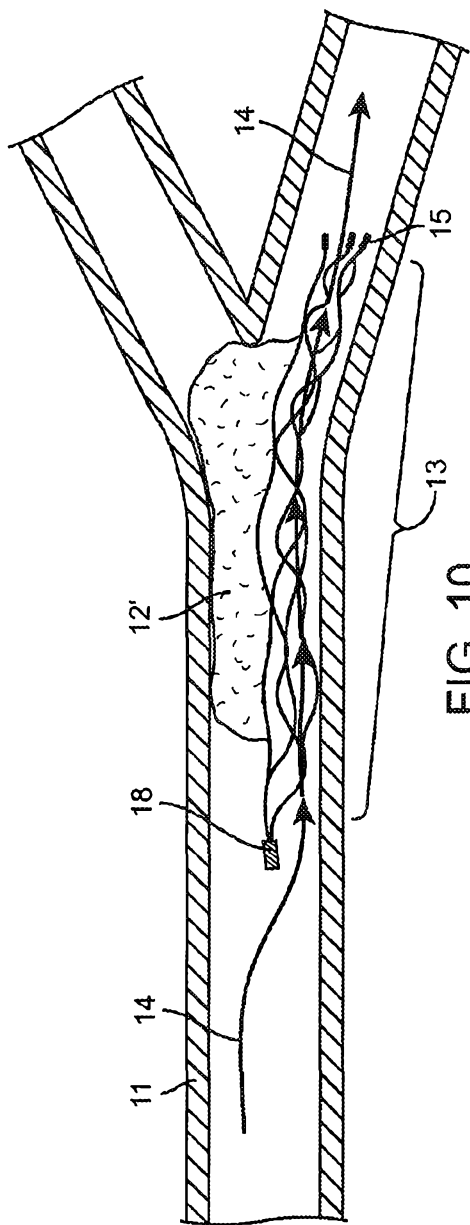

FIG. 10

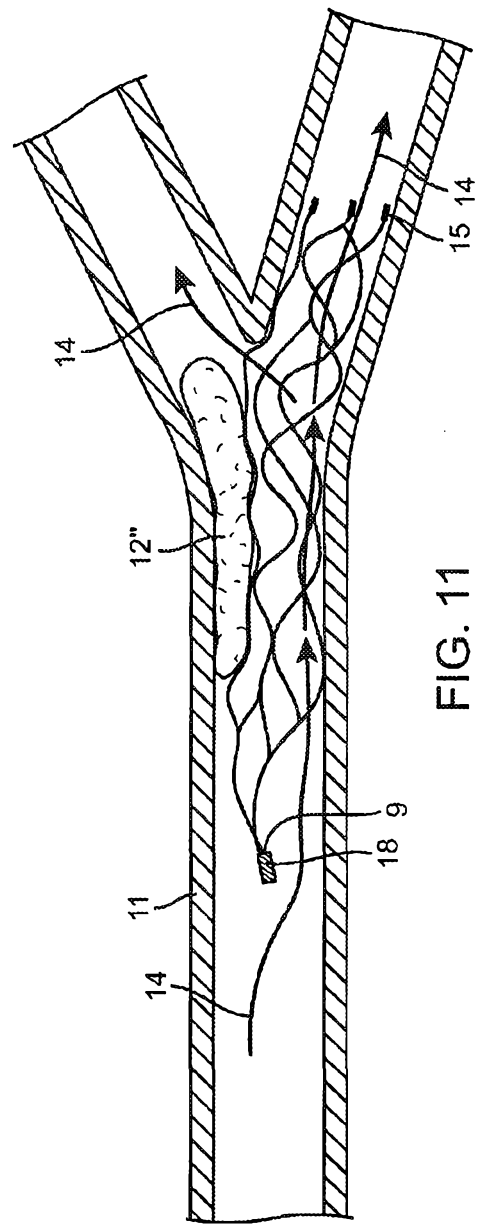

FIG. 11

+

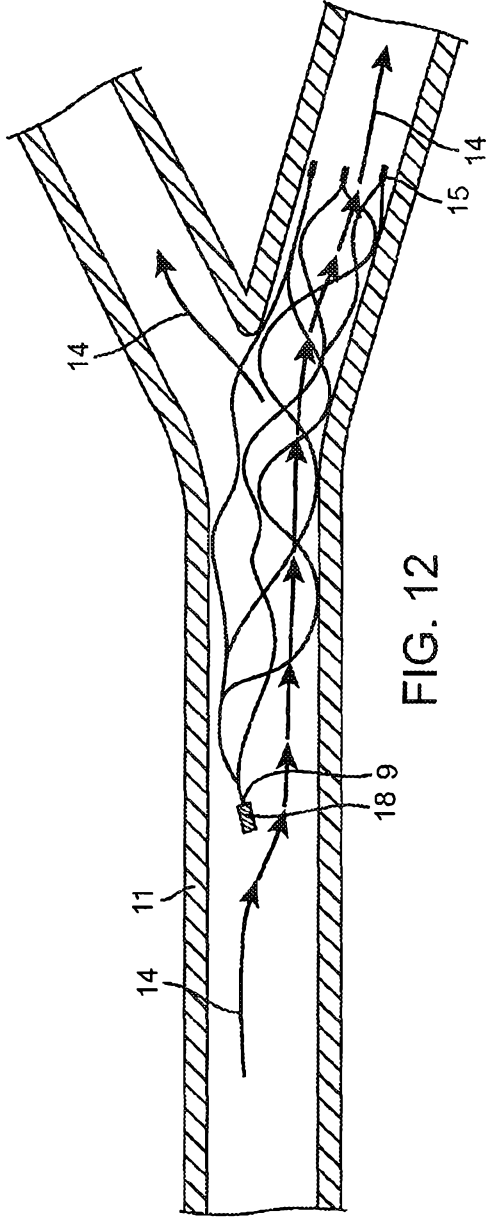

FIG. 12

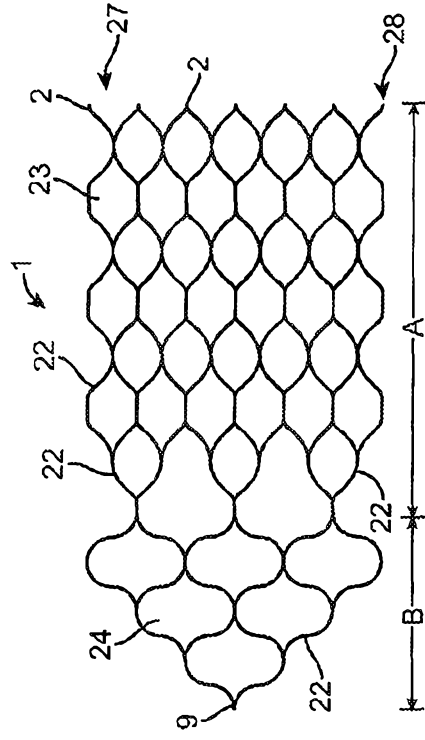

FIG. 13

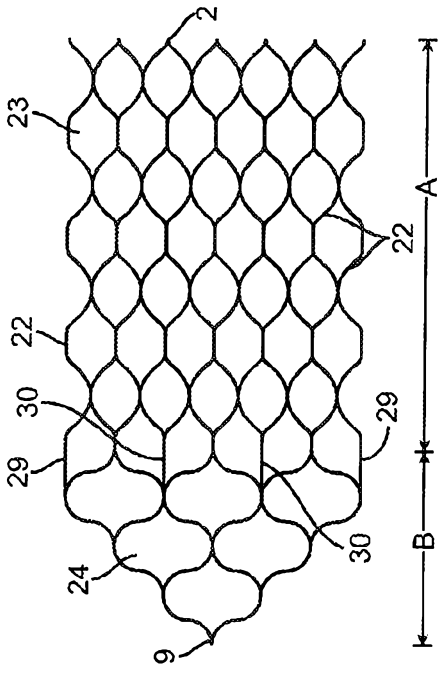

FIG. 14

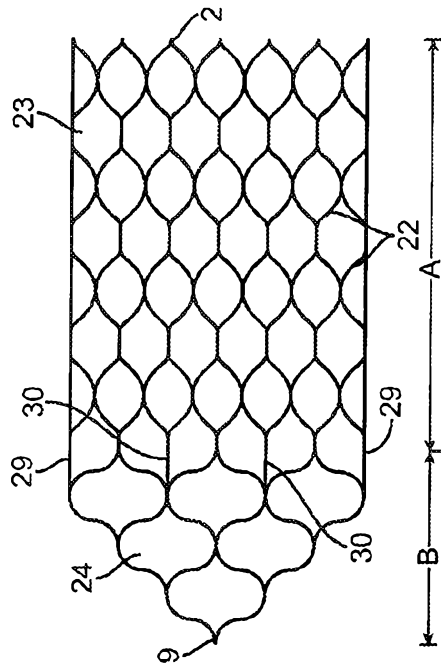

FIG. 15

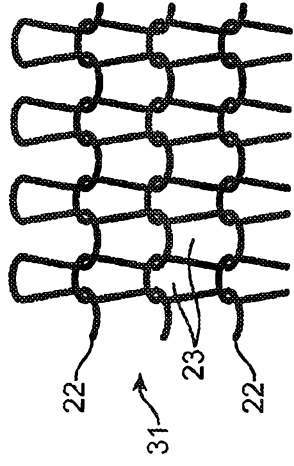

FIG. 16

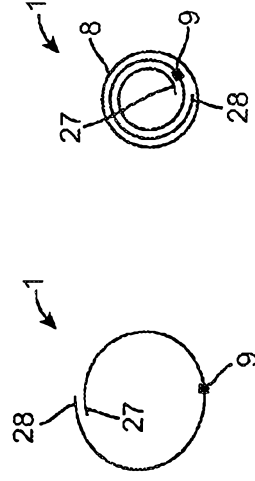

FIG. 17a

FIG. 17b

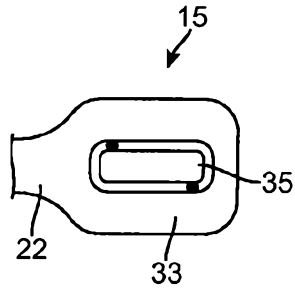

FIG. 18a

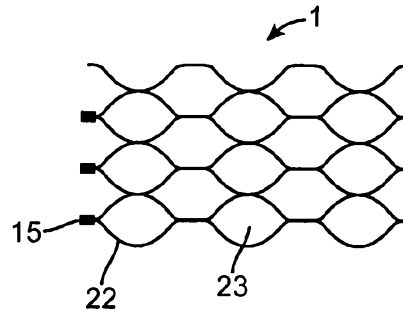

FIG. 18b

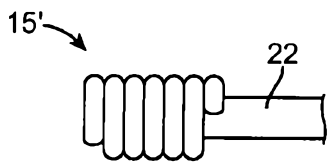

FIG. 18c

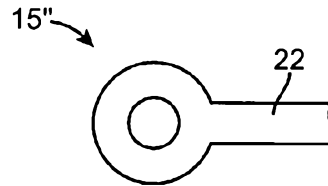

FIG. 18d

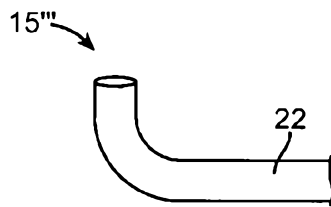

FIG. 18e

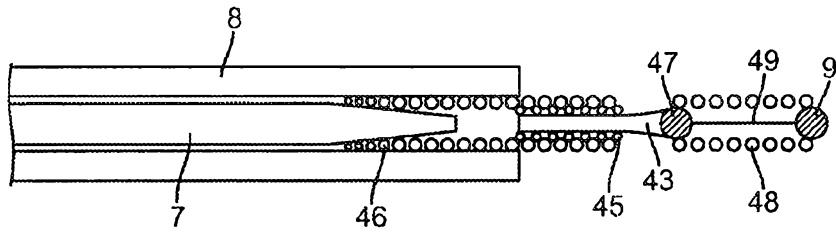

FIG. 19a

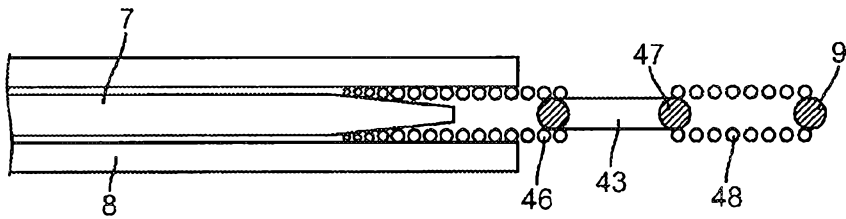

FIG. 19b