

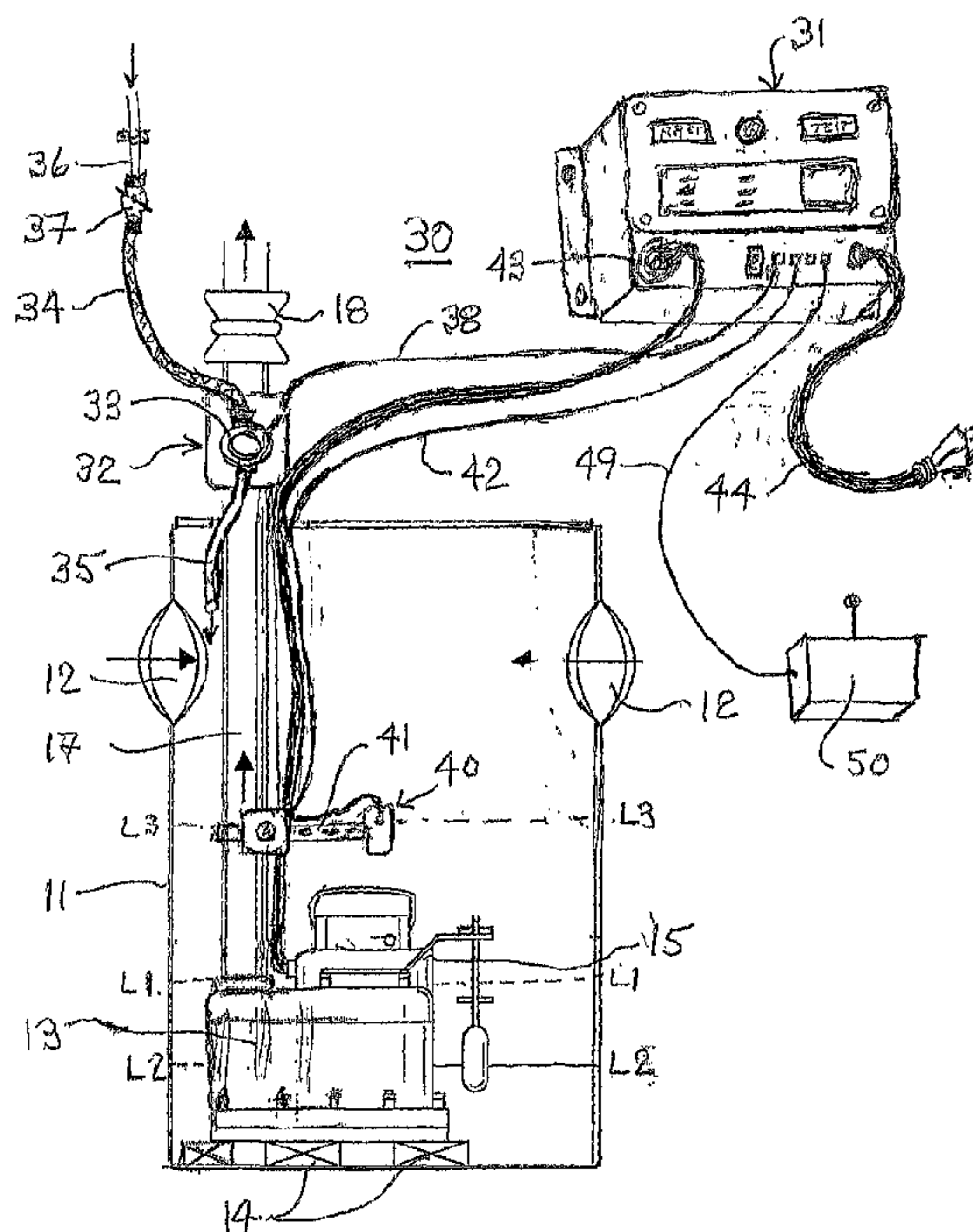

(86) Date de dépôt PCT/PCT Filing Date: 2014/11/13
 (87) Date publication PCT/PCT Publication Date: 2015/06/04
 (45) Date de délivrance/Issue Date: 2019/03/19
 (85) Entrée phase nationale/National Entry: 2016/05/19
 (86) N° demande PCT/PCT Application No.: US 2014/065347
 (87) N° publication PCT/PCT Publication No.: 2015/080866
 (30) Priorités/Priorities: 2013/11/26 (US61/908,881);
 2014/05/19 (US14/281,525)

(51) Cl.Int./Int.Cl. *F04B 51/00* (2006.01),
F04B 49/025 (2006.01)
 (72) Inventeur/Inventor:
 CUMMINGS, EUGENE M., US
 (73) Propriétaire/Owner:
 BEACON TECHNICAL SYSTEMS, LLC, US
 (74) Agent: RIDOUT & MAYBEE LLP

(54) Titre : SYSTEME D'ESSAI ET DE CONTROLE DE POMPE DE RELEVAGE
 (54) Title: SUMP PUMP TEST AND MONITORING SYSTEM



(57) Abrégé/Abstract:

A proactive test and monitoring system for a sump pump installation of the type having an electrically-powered sump pump which pumps water from a sump pit to a dispersal site when the water level in the pit rises to a predetermined level. The system includes a control module which is periodically actuated by an event timer to initiate a test cycle wherein a valve is actuated open to admit water into the pit. If the pump is operative, the pump operates and the water level in the pit falls, the test cycle is terminated and a successful test is indicated. If the pump is inoperative, the water level continues to rise and the test cycle is terminated, the valve is closed and an unsuccessful test is indicated.

(12) INTERNATIONAL APPLICATION PUBLISHED UNDER THE PATENT COOPERATION TREATY (PCT)

(19) World Intellectual Property
Organization
International Bureau(10) International Publication Number
WO 2015/080866 A1(43) International Publication Date
4 June 2015 (04.06.2015)

(51) International Patent Classification:

F04B 51/00 (2006.01)

(21) International Application Number:

PCT/US2014/065347

(22) International Filing Date:

13 November 2014 (13.11.2014)

(25) Filing Language:

English

(26) Publication Language:

English

(30) Priority Data:

61/908,881 26 November 2013 (26.11.2013) US

14/281,525 19 May 2014 (19.05.2014) US

(72) Inventor; and

(71) Applicant : CUMMINGS, Eugene, M. [US/US]; 1290
Kathryn Lane, Lake Forest, IL 60045 (US).(74) Agent: MUNDT, David M.; Eugene M. Cummings, P.C.,
55 West Monroe, Suite 3500, Chicago, Illinois 60603
(US).(81) Designated States (unless otherwise indicated, for every
kind of national protection available): AE, AG, AL, AM,AO, AT, AU, AZ, BA, BB, BG, BH, BN, BR, BW, BY,
BZ, CA, CH, CL, CN, CO, CR, CU, CZ, DE, DK, DM,
DO, DZ, EC, EE, EG, ES, FI, GB, GD, GE, GH, GM, GT,
HN, HR, HU, ID, IL, IN, IR, IS, JP, KE, KG, KN, KP, KR,
KZ, LA, LC, LK, LR, LS, LU, LY, MA, MD, ME, MG,
MK, MN, MW, MX, MY, MZ, NA, NG, NI, NO, NZ, OM,
PA, PE, PG, PH, PL, PT, QA, RO, RS, RU, RW, SA, SC,
SD, SE, SG, SK, SL, SM, ST, SV, SY, TH, TJ, TM, TN,
TR, TT, TZ, UA, UG, US, UZ, VC, VN, ZA, ZM, ZW.(84) Designated States (unless otherwise indicated, for every
kind of regional protection available): ARIPO (BW, GH,
GM, KE, LR, LS, MW, MZ, NA, RW, SD, SL, ST, SZ,
TZ, UG, ZM, ZW), Eurasian (AM, AZ, BY, KG, KZ, RU,
TJ, TM), European (AL, AT, BE, BG, CH, CY, CZ, DE,
DK, EE, ES, FI, FR, GB, GR, HR, HU, IE, IS, IT, LT, LU,
LV, MC, MK, MT, NL, NO, PL, PT, RO, RS, SE, SI, SK,
SM, TR), OAPI (BF, BJ, CF, CG, CI, CM, GA, GN, GQ,
GW, KM, ML, MR, NE, SN, TD, TG).

Published:

— with international search report (Art. 21(3))

(54) Title: SUMP PUMP TEST AND MONITORING SYSTEM

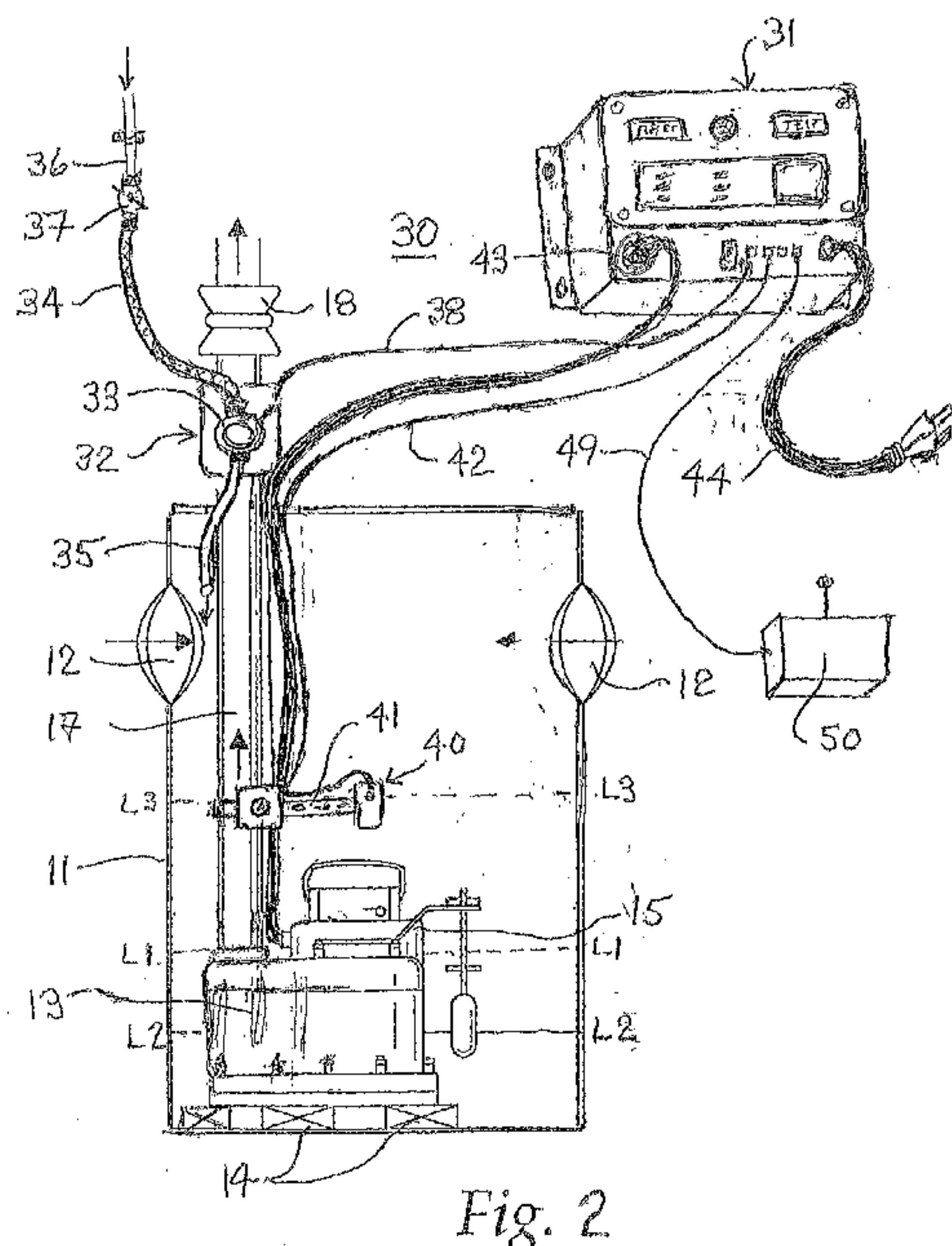

Fig. 2

(57) Abstract: A proactive test and monitoring system for a sump pump installation of the type having an electrically-powered sump pump which pumps water from a sump pit to a dispersal site when the water level in the pit rises to a predetermined level. The system includes a control module which is periodically actuated by an event timer to initiate a test cycle wherein a valve is actuated open to admit water into the pit. If the pump is operative, the pump operates and the water level in the pit falls, the test cycle is terminated and a successful test is indicated. If the pump is inoperative, the water level continues to rise and the test cycle is terminated, the valve is closed and an unsuccessful test is indicated.

SUMP PUMP TEST AND MONITORING SYSTEM

BACKGROUND OF THE INVENTION

[2] The present disclosure relates to an automated system for monitoring and testing sump pump installations of the type commonly used in residential and commercial building basements. In particular, the disclosure is directed to a monitoring system for a sump pump installation which regularly tests and monitors the installation and proactively provides confirmation of a successful test and an alarm in the event of an unsuccessful test.

[3] More specifically, sump pump installations are frequently provided in residential and commercial basements to remove ground water that accumulates around foundation footings and under the basement floor. To this end, a network of apertured drain tiles or flexible drain hoses is laid adjacent to the footings of the foundation walls on either the interior side or the exterior side of the walls, or both. These drain tiles or hoses are appropriately routed and sloped to drain accumulated water into one or more sump liners, which typically have inlets connecting with the network of drain tiles/hoses and are set in the basement floor to form a sump pit having a bottom portion below that of the tiles/hoses, The most commonly used type of sump pumps are

electrically-powered sump pumps designed to be completely submerged by water in the sump pit. At least one electrically-powered sump pump is typically positioned in the sump pit and, when powered, functions to discharge water from the pit through a discharge pipe to a dispersal location, such as a storm sewer or exterior dispersal field. The sump pump typically includes a float switch which causes it to operate when the level of ground water (or other liquid) in the sump pit has reached a predetermined trigger level, ordinarily set below the lowest inlet in the liner wall. That float switch also typically terminates operation of the pump when the water reaches a predetermined minimum level below the trigger level. A check valve prevents water remaining in the discharge pipe from flowing back into the sump pit.

[004] Should the sump pump fail to operate for any reason, such as, for example, motor failure, pump failure, or power failure, and should the drain network continue to flow water into the sump pit, the pit will often eventually overflow from the top of the sump liner and flood into the basement. This flooding may result in significant and often costly damage to items stored in the basement, as well as to existing basement improvements such as finished walls and furniture.

[005] Various monitoring systems have come into use for warning the home or business owner of an impending overflow of the sump pit. Typically, these rely on a float switch or other types of liquid level detectors to sense an abnormally high liquid level in the sump pit and to cause an alarm to be sounded and/or a warning message to be sent to the owner. The drawback of these systems is that they only function when the pump is already in a condition in which it is no longer capable to prevent flooding, i.e. when the pump has failed and the pit is about to overflow. This is frequently too late for corrective action to be taken.

[006] Another type of monitoring system that has come into use provides an independent liquid level sensing float switch, or other equivalent liquid level sensing device, in

the pit which functions to supply power to the pump when a predetermined trigger level is reached. The current drawn by the motor and a fall in the liquid level in the pump is then utilized to confirm operation of the pump. Unfortunately, an alarm is only sounded at a time when operation of the pump is required to prevent flooding but the pump does not operate. This, again, may be too late for any corrective action to be taken.

[007] Still other monitoring systems attempt to reduce the likelihood of an overflow by providing a second back-up pump, typically set at a slightly higher level in the pit so as to operate only upon failure of the first pump, or an AC backup power source, such as a standby generator or a battery-powered inverter. Other systems provide an independent second DC battery-driven pump in the sump pit alongside the main AC-driven pump. Another monitoring system, in addition to providing two pumps in the sump pit, causes the pumps to alternate in operation in response to incoming ground water. While the provision of these systems may reduce the likelihood of a system failure, they do not proactively identify a pump failure prior to an impending flood event requiring reliable operation of the pump.

[008] In contrast, the test and monitoring system of the present disclosure periodically confirms the operability of a sump pump installation and alerts the owner of a malfunction prior to the sump installation being required to operate to discharge drain water. This gives the owner sufficient time to correct the malfunction and thereby avoid what might otherwise be a serious basement flooding event. In the event the test and monitoring system of the disclosure is utilized in a two pump installation, both pumps are independently tested and monitored, and a failure of either pump, or both pumps, results in an alarm being sounded and appropriate messages being sent to the owner and/or the owners' designee(s) by communications channels such as, for example, the Internet, cell phone data or land line telephone communication channels.

[009] Moreover, the regular and automatic testing provided by the test and monitoring system of the present disclosure has the further benefit of periodically placing any sump pumps in the monitored system in full operation to actually discharge water from the sump pit, thereby helping to prevent seals and bearings in the pump(s) and their motor(s) and associated check valve(s) from drying out or binding. Prior monitoring systems are reactive in that they act only in the event the monitored sump installation is called on to evacuate rising ground water, which may be only after extended periods of non-operation.

[010] Accordingly, it is a general object of the present disclosure to provide an improved automatic test and monitoring system for a sump pump installation.

[011] It is a more specific object of the present disclosure to provide an automatic sump pump test and monitoring system which functions proactively to alert a user to a malfunctioning sump pump installation prior to the installation being required to prevent an impending overflow and flood condition.

[012] It is a still more specific object of the present disclosure to provide a sump pump test and monitoring system which periodically tests the operation of a sump pump installation and provides an alarm to the user in the event the installation fails to perform satisfactorily.

[013] It is yet another specific object of the disclosure to provide a sump pump test and monitoring system which regularly admits liquid to the sump pump container of a sump pump installation to force the sump pump of the installation through a test cycle whereby satisfactory operation can be verified in advance of any actual need for the pump installation.

BRIEF SUMMARY OF THE INVENTION

[014] In accordance with the disclosure, an automated system for monitoring and testing a sump pump installation of the type having a liquid container, a motor driven pump positioned within the container which when powered discharges liquid from the container, and a switch circuit which supplies current to power the pump motor upon the liquid level in the container having risen to a first predetermined level, comprises a liquid conduit including an electrically-actuated valve which admits liquid to the liquid container in response to a valve control signal, a test control module which supplies a valve control signal to the valve to initiate a test cycle during which liquid is admitted to the container to cause the liquid level in the container to rise to at least the first predetermined level, after which the pump discharges liquid from the container until a predetermined event terminates the test cycle, and wherein the test control module further includes an indicator circuit which indicates in response to completion of the test cycle whether the test was successful or unsuccessful.

[015] In further accord with the disclosure in the above described system, the test control module terminates supplying the valve control signal to the valve upon the liquid level in the container having risen to a second predetermined level to prevent further flow of liquid through the liquid conduit to the container.

[016] In further accord with the disclosure, in the above described system the indicator circuit further indicates upon the liquid level in the container rising to a second predetermined level the occurrence of an unsuccessful pump test.

[017] In further accord with the disclosure, an automated system for testing and monitoring a sump pump installation of the type having a liquid container, a motor driven pump positioned within the container which when powered discharges liquid from the container, and a

switch circuit which supplies current to power the pump motor upon the liquid level in the container having risen to a first predetermined level, comprises a liquid conduit including an electrically-actuated valve which admits liquid to the container in response to a valve control signal, a test control module which supplies a valve control signal to initiate a test cycle during which liquid is admitted to the container to cause the liquid level therein to rise to at least the first predetermined level, after which the pump, if functioning, discharges liquid from the container until a predetermined event terminates the test cycle, wherein the test control module further includes an indicator circuit which, in the event of the pump being functional, indicates upon completion of the test cycle the occurrence of a successful test, and wherein in the event of the pump being nonfunctional, the indicator circuit indicates in response to the liquid level in the container continuing to rise the occurrence of an unsuccessful pump test.

[018] In further accord with the disclosure, in the above described system the test control module terminates the valve control signal upon the liquid level in the container having risen to a second predetermined level to prevent further inflow of liquid to the container through the liquid conduit.

BRIEF DESCRIPTION OF THE DRAWINGS

[019] The present disclosure will be more fully understood by reference to the following detailed description of one or more preferred embodiments when read in conjunction with the accompanying drawings, in which like referenced characters refer to like elements throughout the drawings, and in which:

[020] Figure 1 is a simplified cross-sectional view partially in perspective of a conventional single sump pump installation having a liquid container, a motor-driven pump, a float switch integral to the pump, a pump discharge pipe and a high liquid level alarm.

[021] Figure 2 is a simplified cross-sectional view partially in perspective of a single sump pump installation which incorporates an automated test and monitoring system constructed in accordance with the present disclosure.

[022] Figure 3 is an enlarged perspective view of the solenoid-actuated liquid valve assembly utilized in the test and monitoring system of Figure 2.

[023] Figure 4 is an enlarged cross-sectional view partially in perspective of the solenoid-actuated valve assembly of Figure 3.

[024] Figure 5 is an enlarged perspective view in cross section showing the float switch assembly utilized in the test and monitoring system of Figure 2.

[025] Figure 6 is an enlarged cross-sectional view partially in perspective of the float switch utilized in the float switch assembly of Figure 5.

[026] Figure 7 is an enlarged perspective view of the control module of the sump pump test and monitoring system of Figure 2 adapted for mounting on a wall or other flat support surface.

[027] Figure 8 is an enlarged perspective view in an alternate housing construction for the control module of Figure 7 adapted for mounting directly on the discharge pipe of the sump pump installation.

[028] Figure 9 is a simplified functional block diagram partially in schematic form showing the principal components of the test and monitoring system of Figure 2.

[029] Figure 10 is a simplified functional block diagram partially in schematic form showing the implementation of the test and monitoring system of Figure 9 utilizing a microprocessor.

[030] Figure 11 is a cross-sectional view partially in perspective showing an automated test and monitoring system constructed in accordance with the disclosure in use with a dual pump sump pump installation.

[031] Figure 12 is an enlarged perspective view of the control module utilized in the sump pump test and monitoring system of Figure 11.

[032] Figure 13 is a simplified functional block diagram partially in schematic form showing the principal components of the test and monitoring system of Figure 11.

[033] Figure 14 is a simplified functional block diagram partially in schematic form showing the implementation of the test and monitoring system of Figure 13 utilizing a microprocessor.

DETAILED DESCRIPTION OF THE EMBODIMENTS

[034] The following description of the preferred embodiments is merely exemplary in nature and is no way intended to limit the disclosure, its application or use.

[035] Referring to Figure 1, a sump pump installation 10 of the type commonly used in basements of homes or businesses generally consists of a sump container or liner 11 having multiple inlets 12 through which drain water is received from one or more perforated hose or tile systems (not shown) disposed around the foundation footings of the building in which the sump pump installation is located. A motor driven sump pump 13 is typically positioned at or near the bottom of container 11, and may be supported by one or more bricks 14 or other spacers located

between sump pump 13 and the bottom of container 11. Sump pump 13 may include an integral float switch assembly 15 which forms part of an electric circuit including a power cord 16 which supplies electric power to the pump motor upon the water level in container 11 rising to a first predetermined level L1. This causes pump 13 to discharge water from container 11 through a discharge pipe 17 and a conventional check valve 18 to a storm drain or other water dispersal facility (not shown). A first float switch assembly 15 interrupts the application of electric power to the pump motor when the water level in container 11 falls to a second predetermined level L2 below the first predetermined level L1.

[036] Frequently, a high water monitoring system 20 may be provided to signal that the water level in container 11 has risen to a third predetermined level L3 above the first predetermined level L1, and therefore above the normal operating range of pump 13 to alert the user of a possible pump failure. In the illustrated embodiment of Figure 1, monitoring system 20 includes a second float switch assembly 21 positioned within container 11 such that when the water level in the container rises to the third predetermined level L3, float switch 21 closes and provides an actuating signal through a cable 22 to an alarm module 23. The alarm module 23 may include an aural alarm transducer 24 and a connector 25 for remotely signaling the high water condition. Power may be supplied to the high water monitor system 20 by means of a conventional power cord 26.

[037] Sump pump 13 in the embodiment of Figure 1 is connected directly to the AC line by cable 16, the integral float switch assembly 15 serving to control the application of AC power to the pump motor. In other embodiments, sump pump 13 may be provided with an external non-integral float switch (not shown) which may be separately connected through another cable (not shown) to the AC power source of the pump. Typically, the additional cable is provided with a

break-out connector (not shown) which includes an AC plug for insertion into an AC supply wall outlet on one side and a switched AC receptacle on the opposite side for receiving the AC plug on the end of the pump power cord. The AC plug is inserted into the AC supply receptacle and the AC plug associated with the pump motor is inserted into the switched AC receptacle of the break-out connector. This has the advantage of allowing float switch assembly 15 to be replaced without replacing or dismantling sump pump 13, and enables sump pump 13 to be tested by removing the AC plug of the pump power cord from the break-out connector and inserting the conventional AC plug of the pump motor directly into the AC supply wall outlet.

[038] In other embodiments, an independent control circuit (not shown) is provided for powering the pump motor. In these installations, the pump motor has no associated flow switch and receives operating power from the independent control system. The independent system may include one or more float switches or other water level detecting devices which cause the pump motor to be powered and unpowered as the water level in the sump container rises and falls to predetermined levels. These independent pump control systems may include means for monitoring the current draw of the motor to provide an alarm in the event of pump motor failure.

[039] Referring to Figure 2, a sump pump test and monitoring system 30 constructed in accordance with one embodiment of the disclosure is provided to automatically and proactively test and monitor the operation of the sump pump installation and provide an alarm in the event of the sump pump installation failing to operate. System 30 includes a control module 31 which contains the electronic circuitry and various switches, indicators and connectors associated with the system. System 30 further includes in accordance with the disclosure a valve assembly 32 for admitting fresh water to container 11. Valve assembly 32 is mounted directly on pump discharge pipe 17 and includes a solenoid-actuated valve 33 which is connected on one side to a fresh

water supply (not shown) by a length of flexible tubing 34 and on its other side to container 11 by a length of semi-rigid copper tubing 35. The fresh water source is preferably accessed by a length of copper tubing 36 which extends from the source and connects to the length of flexible tubing 34 through a manual shutoff valve 37. The solenoid of solenoid valve 33 is electrically connected to control module 31 by a cable 38. Valve assembly 32, together with the length of flexible tubing 34 and the length of semi-rigid copper tubing 35 provides a fluid conduit which supplies fresh water to container 11 when called for by test and monitoring system 30.

[040] Test and monitoring system 30 further includes a float switch assembly 40 positioned within container 11 at a predetermined level L3 by an adjustable bracket 41 secured to pump discharge pipe 17. Upon the water level in container 11 rising to level L3, float switch assembly 40 is actuated and provides an electrical signal to circuitry within control module 31 through a cable 42 which signals that the water level in container 11 has risen to a level above the maximum level that would be achieved if sump pump 13 were operative.

[041] Control module 31 includes an AC receptacle 43 for receiving a conventional AC plug on the end of the power cord 16 of pump motor 13. Control Module 31 also includes an AC power cord 44 for receiving AC power from an AC supply wall receptacle (not shown). In one embodiment, four connectors 45-48 (see Figure 7) are provided on the front panel of control module 31 to connect to the various components of system 30. In particular, connector 45 connects to cable 38 of the valve assembly 33, connector 46 connects to cable 42 of float switch assembly 40, connector 48 connects through a cable 49 to an (optional) external communication module 50, and connector 47 provides dry contacts for connection to an external alarm system.

[042] As shown in Figures 3 and 4, solenoid actuated valve assembly 32 includes a base member 51 on which the solenoid-actuated valve 33 is mounted by machine screws 39 or other

appropriate means. It will be appreciated that other valve mounting configurations may be provided as dictated by the construction of the valve body. Valve 33, which may be conventional in design and construction, includes a solenoid actuator 52 and conventional inlet and outlet fittings 53 and 54 on respective sides of the valve to receive and engage conduits 34 and 35, respectively. A removable cover 55 dimensioned to securely engage the rim of base member 51 is preferably provided to protect the valve from mechanical damage. The cover may include slots 56 and 57 to accommodate the tubing segments on either side of the valve. The cover may be secured in place by a plurality of (machine) screws 58 threaded into the top surface of base member 51. Base member 51 is preferably provided with an appropriately shaped laterally-extending channel 60 (see Figure 3) on its bottom surface to contiguously engage the outer surface of discharge pipe 17. Two laterally-spaced adjustable retaining straps 61 and 62 (see Figure 4) are provided to firmly secure base member 51 to discharge pipe 17.

[043] Referring to Figure 5, float switch assembly 40 includes an adjustable bracket 41 which is secured to pump discharge pipe 17 by means of a base member 65. Base member 65 includes a laterally-extending channel 66 on its rear surface shaped to contiguously engage the outer surface of pump discharge pipe 17. An adjustable strap 67 extends from base member 65 around discharge pipe 17 to draw the base member tightly against the pipe and thereby hold float switch assembly 40 firmly in position.

[044] As shown in Figure 6, float switch assembly 40 includes a generally cylindrical housing 68 forming a chamber 70. Housing 68 includes a plurality of apertures 71 through which liquid is admitted into the chamber. A float switch assembly 72 is provided within chamber 70. Float switch assembly 40 further comprises a hollow shaft 73 formed of a non-magnetic chamber material within which at least one magnetically-actuated reed switch 74 is positioned. A toroid-

shaped float assembly 75 containing an internal magnet is dimensioned to slide along the axis of shaft 73 as the water level rises and falls within the chamber. A pair of washers 76 and 77 attached to shaft 73, limit the axial movement of float assembly 75 such that the magnet in float assembly 75 overlies and actuates reed switch 74 as it reaches its maximum level. Reed switch 74 is electrically connected to module 31 by cable 42 to signal the circuitry within the module that the reed switch has been actuated by the water level in container 11 rising to level L3. Switch assembly 72 is held in position along the axis of cylindrical chamber 70 by a threaded end portion 78 of shaft 73 secured to the upper end of the housing by appropriate mounting hardware 79.

[045] It will be appreciated that the liquid level sensing function of float switch assembly 40 can be accomplished by other forms of water level detectors. For example, a conventional float switch of the type having a float and an arm connected to a mechanically actuated switch can be utilized. Or, an electronic switch either of the type which senses conductivity between two sensing electrodes, or of the type that senses water pressure on a submerged pressure transducer, can be utilized.

[046] As shown in Figure 7, control module 31 of test and monitoring system 30 may include a generally rectangular housing 80 having flanges 81 and 82 for mounting to a wall or other flat support surface. Front panel 83 of the module may include a three-color LED indicator lamp 84 for visually indicating the status of the sump pump installation being tested and monitored. In a preferred embodiment, this indicator illuminates green for a functioning pump installation, red for a non-functioning pump installation, and amber for a pump installation under test. The amber indication may be flashing while the solenoid-actuated valve 33 is admitting water to container 11. A test of the sump pump installation can be manually initiated by means of

a push-button TEST switch 85 located on front panel 83. Momentarily pressing switch 85 initiates a normal test cycle of the pump sump installation. An unsatisfactory test result is signaled to the user by indicator 84 flashing red and an aural alarm provided by a panel-mounted transducer 86. The aural alarm, which is preferably in the form of a loud repetitive “chirp,” can be reset by momentary actuation of a push-button RESET switch 87, also located on front panel 83. Momentarily pressing this switch will silence the chirp and change the accompanying flashing red indication of indicator 84 to a steady red indication for a predetermined period of time, such as six hours, after which the chirp and flashing red indication again occur. Shorter or longer time periods for muting the alarm can be programmed into system 30 as desired.

[047] Actuating RESET switch 87 for an extended period of time, such as for five seconds, will result in a complete reset of the system. The flashing or steady red illumination of indicator 84 will extinguish and the chirp provided by transducer 86 will cease. However, a green illumination of indicator 84 indicating a satisfactory pump installation test will not occur until test switch 85 has been subsequently actuated and a subsequent test of the installation has been satisfactory.

[048] Various fault details, such as low battery, AC supply failure, pump motor timeout, high water level, pump motor fail and communications fail, may be provided by plurality of indicator lamps 88a-88f on front panel 83. In addition, a removable cover 89 may be provided to access a rechargeable battery (not shown in Figure 7) provided in housing 80 to power the test and monitoring system circuitry within module 31 in the event of AC power failure.

[049] Referring to Figure 8, control module 31 of test and monitoring system 30 may be contained in an alternative housing 90 adapted to be mounted directly on the outer surface of pump discharge pipe 17. In this embodiment, rear wall 91 of housing 90 is provided with a

channel 92 shaped to contiguously engage the outer surface of discharge pipe 17. A pair of adjustable straps (not shown) extends from rear wall 91 and wrap around discharge pipe 17 to draw housing 90 into contiguous firm engagement with pipe 17. The same controls, indicators and connectors present in the embodiment of Figure 7 can be provided in this embodiment.

[050] Figure 9 illustrates the principal components of one embodiment of the test and monitoring system 30 of the present disclosure in a simplified functional block diagram . As shown therein, the occurrence of a test cycle is determined by a TEST CYCLE LATCH 100 which transitions to a SET state during the occurrence of a test cycle, and to a RESET state in the absence of a test cycle. In normal use, TEST CYCLE LATCH 100 is periodically conditioned to a SET state by an EVENT TIMER 101 which provides a momentary output signal through OR gate 120 after a predetermined time interval has lapsed following the most recent input applied to the timer. In one embodiment, EVENT TIMER 101 may be set, for example, to generate a momentary output signal seven days after receipt of the most recent input signal, in which case a test cycle of the sump pump installation will occur at periods of not more than seven days.

[051] When TEST CYCLE LATCH 100 is in a SET state, a signal is also applied through AND gate 102 and solenoid driver circuit 103 to solenoid 52 of valve assembly 33 to condition valve assembly 33 to admit water to container 11. Water continues to be admitted until either TEST CYCLE LATCH 100 reverts back to a RESET state, or the high water float switch assembly 40 provides an inhibit signal to AND gate 102. When valve assembly 33 is open, FLASHER CIRCUIT 99 is activated to cause the amber illumination of indicator 84, if active, to flash.

[052] When TEST CYCLE LATCH 100 is in a SET state, it provides an output signal causing indicator 84 to illuminate amber through AND gate 104 and LED driver 105. Also,

TEST CYCLE LATCH 100 in its SET state resets the TEST SUCCESSFUL LATCH 106 through signal conditioning pulse circuit 107 and OR gate 108, and resets the TEST FAIL LATCH 111 through OR gate 95. This terminates the output of TEST SUCCESSFUL LATCH 106 such that the green illumination of indicator 84 driven through LED driver 109 is extinguished, and the output of TEST FAIL LATCH 111 such that the red illumination of indicator 84 driven through AND gate 96 and LED driver 113 is extinguished. Thus, only the amber illumination of indicator 84 is active during a test cycle.

[053] The output of TEST CYCLE LATCH 100 is also applied to a TEST CYCLE TIMER 110 which times the duration of the test cycle and provides a momentary timeout output signal in the event the duration of the SET state of TEST CYCLE LATCH 100, and hence the duration of the test cycle, exceeds a predetermined maximum period of time. In the event of this timeout, TEST CYCLE TIMER 110 applies a SET signal to transition TEST FAIL LATCH 111 to a SET state through OR gate 112. This causes a red illumination of indicator 84 through AND gate 93 and LED driver 113. Also, the output of TEST CYCLE TIMER 110 causes TEST CYCLE LATCH 100 to be reset by means of a signal provided through OR gate 114, thereby extinguishing the amber illumination of indicator 84. The output of TEST FAIL LATCH 111 conditions ALARM LATCH 115 to a SET state through an interface circuit 116, thereby causing an AUDIO GENERATOR 95 to generate an audible alarm, such as a recurrent chirping sound. ALARM LATCH 115 can be reset by momentary actuation of RESET switch 87, in the manner previously described. ALARM LATCH 115 also enables FLASHER CIRCUIT 94 to cause the red illumination of indicator 84 to flash until the latch is reset. RESET switch 87 also serves, through a delay circuit 117, when held for an extended period of time, to reset TEST CYCLE LATCH 100 through OR gate 114, TEST FAIL LATCH 111 to reset through an OR gate 95, and

TEST SUCCESSFUL LATCH 106 to reset through an OR gate 108, thereby conditioning the system for a subsequent test. A manual test can be initiated by TEST switch 85 through a signal conditioning pulse circuit 119 and OR gate 120.

[054] The output of MOTOR CURRENT SENSOR 121 also provides a reset signal through signal conditioning pulse circuit 122 to EVENT TIMER 101, causing that timer to begin a new timing period with each operation of the motor. The output of MOTOR CURRENT SENSOR 121 is also applied to signal conditioning pulse circuit 123, which provides a momentary pulse upon the motor stopping. This pulse, signaling the completion of a successful test, is applied through OR gate 114 to reset TEST CYCLE LATCH 100 to terminate the test cycle. The same motor stop pulse also serves to condition the TEST SUCCESSFUL LATCH 106 to a SET status to indicate successful completion of a test cycle by illuminating the green indication of indicator 84 through LED driver 109. A further function of MOTOR CURRENT SENSOR 121 is to initiate a timeout period in a MOTOR RUN TIMER 124. In the event pump motor 13 operates continuously for a period exceeding the timeout period of MOTOR RUN TIMER 124, the timer generates an output signal which resets TEST CYCLE LATCH 100 through OR gate 114 and conditions TEST FAIL LATCH 111 to a SET state through OR gate 112. This causes the red illumination of indicator 84 through AND gate 93 and LED driver 113. Also, the output of MOTOR RUN TIMER 124 resets the TEST SUCCESSFUL LATCH 106 through OR gate 108 to extinguish the green illumination of indicator 84.

[055] In the event pump motor 13 fails to operate during a test cycle, the eventual closure of high water sensing switch assembly 40 causes an inhibit signal to be applied to AND gate 102, preventing further operation of solenoid 52 to prevent further water from being admitted to sump container 11. Also, the closure of high water level switch assembly 40 causes a

pulse to be applied through signal conditioning pulse circuit 125 and OR gate 108 to reset TEST SUCCESSFUL LATCH 106, through OR gate 114 to reset the TEST CYCLE LATCH 100, and through OR gate 112 to condition TEST FAIL LATCH 111 to a SET state. Thus, a high water condition for any reason results in the red illumination of indicator 84 while the amber and green illuminations of indicator 84 are extinguished, and in the event of an active test cycle, valve 33 is closed to prevent any further fresh water from being admitted to sump container 11.

[056] The system includes a conventional low voltage power supply 126 for supplying 12 VDC operating power to solenoid-actuated valve 33 and to the various functional circuits of the controller. Power supply 126 includes a rechargeable battery 127 to supply operating power to the control module component in the event of AC power failure. During normal operation AC power is supplied to power supply 126 through AC power cable 44 and an internal protective fuse 128.

[057] The status of TEST FAIL LATCH 111 and TEST SUCCESSFUL LATCH 106 is provided to the external communications module 50 (not shown in Figure 9) through connector 48. Additional status information, including the serial number of the system and the time and nature of an event occurrence, can also be provided to the communications module through this connector.

[058] Referring to Figure 10, many of the functions heretofore described with respect to Figure 9 can be more efficiently accomplished by a microprocessor implementation of the control system. In particular, a single microprocessor 129 can be provided with the various sensing and control inputs previously described and programmed to carry out the logic and timing functions required by the system. Previously described outputs to the green, red and amber indications of indicator 84 can be provided by the processor as well, as can the necessary

data required for communication through communication port 48 to the external communications module 50 (not shown in Figures 9 and 10). The programming of microprocessor 129 is well within the capabilities of one skilled in the art of microprocessors and the preparation of associated firmware and software.

[059] The test and monitoring system described in the disclosure can also be effectively utilized to test and monitor a dual sump pump installation 130. Referring to Figure 11, in a dual sump pump installation, a second motor driven sump pump 131 is provided in sump container 11, typically at a slightly higher level than the first motor driven pump 13. Pump 131, like previously described pump 13, may include an integral float switch 132 which initiates operation of pump 131 when the water level in container 11 rises to a fourth predetermined level L4. Float switch 132 discontinues operation of pump 131 when, as a result of pump 131 discharging water from sump container 11, the water level in container 11 falls to a predetermined lower level L5. As with pump 13, second pump 131 has a discharge pipe 133 through which pump 131 discharges water from container 11. A power cord 134 is provided together with circuitry associated with internal pump float switch 132 to power pump 131. Additional support bricks 14 may be provided to raise pump 131 to a level higher than that of the first pump 13 so that in normal operation pump 131 only operates in the event of failure of the first pump 13.

[060] In accordance with the present disclosure, test and monitoring system 130 includes additional components and circuitry to enable the system to test and monitor two sump pumps in a manner similar to that of previously described test and monitor system 30. Referring to Figure 12, test and monitoring system 130 includes a control module 136 similar to the control module 31 of system 30, except that the module includes a second status indicator light 137 for indicating the operating status of second sump pump 131, and a second AC receptacle 138 for

receiving the AC plug associated with the power cord 134 of pump 131. This control module 136 is intended to be mounted on a flat supporting surface in the same manner as the previously described control module 31. Power is supplied to control module 135 by a power cord 44 in the manner previously described and a communication module 50 (not shown) may be connected to connector 48 as previously described. In addition, solenoid-actuated valve assembly 32 is connected by cable 38 to connector 45, and single float switch assembly 40, set at predetermined high water level L3 (which is still higher than predetermined water trigger level L4 of pump 131), is connected by cable 42 to connector 46. Operation of control module 136 is identical to that of the previously described control module 31 with the exception of the previously identified provision of indicator 137 and receptacle 136 to accommodate the second sump pump 131.

[061] The test and operation of the dual pump test and monitoring system 130 of the present disclosure is illustrated in the simplified functional block diagram of Figure 13. As shown in that figure, the system performs two test cycles in sequence- one for pump 13 and one for pump 131- and separately indicates the success or failure of each by means of separate tri-color indicators 84 and 137.

[062] The pump 13 is tested in the manner previously described in connection with test and monitoring system 30. As before, the occurrence of the first test cycle is governed by TEST CYCLE LATCH 100 which transitions to a SET state during the occurrence of a test cycle, and to a RESET state in the absence of a test cycle. TEST CYCLE LATCH 100 is periodically conditioned to a SET state by EVENT TIMER 101, which provides a momentary output signal after a predetermined time interval has lapsed following the most recent input applied to the timer. EVENT TIMER 101 may be set, for example, to generate a momentary output signal seven days after receipt of the most recent input signal, in which case the first test cycle (and the

second test cycle of system 130) will occur at periods of not more than seven days. As before, it will be appreciated that a greater or lesser test interval may be set by EVENT TIMER 101 as desired by the user.

[063] When TEST CYCLE LATCH 100 is in a SET state, a signal is also applied through AND gate 102 and solenoid driver circuit 103 to solenoid 52 of valve assembly 33 to condition the valve assembly to admit water to sump container 11. Water continues to be admitted until either TEST CYCLE LATCH 100 reverts back to a RESET state, as in the case of a successful test, or the high water float switch assembly 40 provides an inhibit signal to AND gate 102, in the case of an unsuccessful test.

[064] When TEST CYCLE LATCH 100 is in a SET state, it provides an output signal which provides for an amber illumination by indicator 84. Also, TEST CYCLE LATCH 100 in its SET state resets TEST SUCCESSFUL LATCH 106, and TEST FAIL LATCH 111. This terminates the output of these components such that during a test cycle indicator 84 can only present an amber illumination .

[065] As before, the output of TEST CYCLE LATCH 100 is also applied to TEST CYCLE TIMER 110 which times the duration of the test cycle and provides a momentary timeout output signal in the event the SET state of TEST CYCLE LATCH 100, and hence the test cycle of pump 13, exceeds a predetermined maximum time duration. In the event of this timeout, TEST CYCLE TIMER 110 conditions TEST FAIL LATCH 111 to a SET state, causing a red illumination of indicator 84. Also, the output of TEST CYCLE TIMER 110 causes TEST CYCLE LATCH 100 to be reset, thereby terminating the test cycle and extinguishing the amber illumination of indicator 84. The output of TEST FAIL LATCH 111 also conditions ALARM LATCH 115 to a SET state, thereby causing an audible alarm to occur. ALARM LATCH 115

can be reset by momentary actuation of RESET switch 87 in the manner previously described. RESET switch 87 also causes, through delay circuit 117, when held for an extended period of time, the reset of TEST CYCLE LATCH 100, TEST FAIL LATCH 111, and TEST SUCCESSFUL LATCH 106, as well as the to be described counterpart components associated with pump 131, thereby conditioning the system for a subsequent test of the two pumps. As before, a manual test of the first sump pump 13 can be initiated by TEST switch 85 through signal conditioning circuit 119 and OR gate 120.

[066] The output of MOTOR CURRENT SENSOR 121 provides a reset signal through signal conditioning circuit 122 to EVENT TIMER 101, causing that timer to begin a new timing period with each operation of the motor. The output of MOTOR CURRENT SENSOR 121 is also applied to signal conditioning circuit 123, which provides a momentary pulse upon the motor stopping. This pulse, signaling the completion of a successful test, is applied through OR gate 114 to reset TEST CYCLE LATCH 100 to terminate the test cycle. The same motor stop pulse also serves to condition TEST SUCCESSFUL LATCH 106 to a SET status to indicate a successful test of sump pump 13 by illuminating the green indication of indicator 84. A further function of motor current sensor 121 is to initiate a timeout period in MOTOR RUN TIMER 124. In the event pump 13 operates continuously for a period exceeding the timeout period of MOTOR RUN TIMER 124, the timer generates an output signal which resets TEST CYCLE LATCH 100 and conditions TEST FAIL LATCH 111 to a SET state. This causes the red illumination of indicator 84. Also, the output of MOTOR RUN TIMER 124 resets TEST SUCCESSFUL LATCH 106 to extinguish the green illumination of indicator 84 driven by that latch.

[067] In the event pump 13 fails to operate, the eventual closure of high water sensing switch assembly 40 causes an inhibit signal to be applied to AND gate 102, preventing further operation of solenoid 82 and further fresh water from being admitted to sump container 11. Also, as before, the closure of high water level switch assembly 40 causes TEST SUCCESSFUL LATCH 106 and TEST CYCLE LATCH 100 to be conditioned to a RESET state, and TEST FAIL LATCH 111 to be conditioned to a SET state. Thus, a high water condition results in no further water being admitted through valve 33 to sump container 11 and any amber and green illuminations of indicator 84 are extinguished while causing a red illumination of indicator 84.

[068] As with the control module of system 30, the control module of system 130 includes a conventional low voltage power supply 126 for supplying operating power to solenoid-actuated valve 33 and the various functional circuits of the controller. Power supply 126 includes a rechargeable battery 127 to supply operating power to the control module component in the event of AC power failure. During normal operation AC power is supplied to power supply 126 through AC power cable 44 and an internal protective fuse 128.

[069] The status of TEST FAIL LATCH 111 and TEST SUCCESSFUL LATCH 106 as to sump pump 13 is provided to external communications module 50 through connector 48. Additional status information, including the serial number of the system and the time and nature of an event occurrence, can also be provided to the communications module through this connector.

[070] To accommodate testing and monitoring of the second sump pump 131, one embodiment of the dual pump test and monitoring system 130 of the disclosure incorporates additional circuitry within control module 136. As shown in Figure 13, the occurrence of a test cycle for the second pump 131 is determined by a second TEST CYCLE LATCH 140 which

transitions to a SET state during the occurrence of a test cycle for pump 131, and to a RESET state in the absence of such a test cycle.

[071] In accordance with the present disclosure, TEST CYCLE LATCH 140 is conditioned to a SET state by TEST CYCLE LATCH 100 upon that device completing a test cycle for sump pump 13. To that end, the output of the latch is applied to the SET input of latch 140 through a signal conditioning pulse circuit 93.

[072] When TEST CYCLE LATCH 140 is in a SET state, a signal is applied through AND gate 142 and solenoid driver circuit 143 to the solenoid 52 of valve assembly 33 to cause the valve assembly to admit fresh water to sump container 11. Fresh water continues to be admitted until either TEST CYCLE LATCH 140 reverts back to a RESET state, as in the case of a successful test, or the high water float switch assembly 40 provides an inhibit signal to AND gate 142, in the case of an unsuccessful test.

[073] When TEST CYCLE LATCH 140 is in a SET state, it also provides an output signal which provides an amber illumination by indicator 137 through AND gate 144 and LED driver 145. Also, the TEST CYCLE LATCH 140 in its SET state resets a TEST SUCCESSFUL LATCH 146 through a signal conditioning pulse circuit 147 and OR gate 148. This terminates the output of TEST SUCCESSFUL LATCH 146 such that the green illumination of indicator 137 driven through LED driver 149 is extinguished. Thus, only the amber illumination of indicator 137 is present during a test cycle.

[074] The output of TEST CYCLE LATCH 140 is also applied to a TEST CYCLE TIMER 150 which times the duration of the test cycle and provides a momentary timeout output signal in the event the SET state of TEST CYCLE LATCH 140, and hence the test cycle of pump 131, exceeds a predetermined maximum time duration. In the event of this timeout, TEST

CYCLE TIMER 150 conditions TEST FAIL LATCH 151 to a SET state through an OR gate 152. This causes the red illumination of indicator 137 through AND gate 155 and LED driver 153. Also, the output of TEST CYCLE TIMER 150 causes TEST CYCLE LATCH 140 to be reset by means of a signal provided through OR gate 154, thereby extinguishing the amber illumination of indicator 137. The output of TEST FAIL LATCH 151 also conditions ALARM LATCH 115 to a SET state through a signal conditioning pulse circuit 156, thereby causing an audible alarm to occur. Alarm latch circuit 115 can be reset by momentary actuation of RESET switch 87, in the manner previously described. RESET switch 87 also causes, through delay circuit 117, when held for an extended period of time, the reset of TEST CYCLE LATCH 140, TEST FAIL LATCH 151, and TEST SUCCESSFUL LATCH 146, thereby conditioning the system for a subsequent test of pump 131. A manual test of the first and second pumps can be initiated by TEST switch 85 through signal conditioning circuit 119 and OR gate 120.

[075] The output of MOTOR CURRENT SENSOR 161 is applied to signal conditioning pulse circuit 163, which provides a momentary pulse upon the motor stopping. This pulse, signaling the completion of a successful test, is applied through OR gate 154 to reset TEST CYCLE LATCH 140 to terminate the test cycle for second pump 131. The same motor stop pulse also serves to condition TEST SUCCESSFUL LATCH 146 to a SET status to indicate successful completion of a test cycle by illuminating the green indication of indicator 137. A further function of motor current sensor 161 is to initiate a timeout period in MOTOR RUN TIMER 164. In the event pump motor 113 operates continuously for a period exceeding the timeout period of MOTOR RUN TIMER 164, the timer generates an output signal which resets TEST CYCLE LATCH 140 through OR gate 154 and conditions TEST FAIL LATCH 151 to a SET state through OR gate 152. This causes the red illumination of indicator 137 through LED

driver 153. Also, the output of MOTOR RUN TIMER 164 resets TEST SUCCESSFUL LATCH 146 through OR gate 148 to extinguish the green illumination of indicator 137 driven by that latch through LED driver 149.

[076] In the event pump motor 131 fails to operate, the eventual closure of high water sensing switch assembly 40 causes an inhibit signal to be applied to AND gate 142, preventing further operation of solenoid 52 to prevent further fresh water from being admitted to sump container 11. Also, the closure of high water level switch assembly 40 causes a pulse to be applied through signal conditioning pulse circuit 165 and OR gate 148 to reset TEST SUCCESSFUL LATCH 146, and through OR gate 154 to reset TEST CYCLE LATCH 140, and through OR gate 152 to condition TEST FAIL LATCH 151 to a SET state. Thus, a high water condition results in no further water being admitted through valve 33 to sump container 11 and any amber and green illuminations of indicator 137 are extinguished while causing a red illumination of indicator 137. As previously described in connection with the single pump system 30, a FLASHER CIRCUIT 172 may be provided to cause a flashing red illumination of indicator 137 prior to actuation of RESET switch 87, and a FLASHER CIRCUIT 173 may be provided to cause a flashing amber illumination of indicator 137 when TEST CYCLE LATCH 140 is SET and valve 33 is open.

[077] The status of TEST FAIL LATCH 151 and TEST SUCCESSFUL LATCH 146 is provided to external communications module 50 (not shown in Figure 13) through connector 48. Additional status information related to pump 131, including the time and nature of an event occurrence, can also be provided to the communications module through this connector.

[078] To provide for sequential testing of pumps 31 and 131, the AC supply circuit to the pump motors includes single pole normally closed relays 168 and 169 and associated

respective relay driver circuits 170 and 171. When TEST CYCLE LATCH 100 is in a SET state to test the motor of pump 13, relay 168 associated with pump 131 is energized open, preventing the motor of pump 131 from operating. Subsequently, when TEST CYCLE LATCH 140 is in a SET state to test the motor of pump 131, relay 169 associated with pump 13 is energized open, preventing the operation of the motor of pump 13. Thus, each motor of each pump is independently tested.

[079] Referring to Figure 14, many of the functions heretofore described with respect to Figure 13 can be more efficiently accomplished by a microprocessor implementation of the control system. In particular, a single microprocessor 180 can be provided with the various sensing and control inputs previously described and programmed to carry out the logic and timing functions required by the system. Previously described outputs to cause the green, red and amber illuminations of indicators 84 and 137 can be provided by processor 180 as well, as can the necessary data required for communication through communication port 48 to external communications module 50 (not shown in Figures 13 and 14). The programming of microprocessor 180 is well within the capabilities of one skilled in the art of microprocessors and the preparation of associated firmware and software.

[080] Thus, each of the two pumps 13 and 131 in sump container 11 is individually monitored and the successful or unsuccessful test of each pump is separately indicated. Additional reporting is provided to communications module 50 to indicate the status of each pump. Visual and aural warnings are given in the event that either pump 13 or pump 131 is inoperative. Thus, the dual pump system 130, like the single pump system 30, is fully automated and proactively provides the user with a warning of pump failure prior to the pump actually being required for evacuating ground water from the pump reservoir. As before, it is

contemplated that additional functions, such as power failure or low battery, or a low temperature condition in the environment of the pump system can also be communicated by means of the communications module. The communications module may communicate with the user by means of an internet connection, a cellular data connection, a phone connection, or by means of a hardwired connection to a separate building alarm system, to the owner or one or more persons designated by the owner of the system.

[081] The information given to the user can include the time and date of the successful tests, the time and date of unsuccessful tests and additional information such as power failure or temperatures falling below a predetermined level. The information can be copied or redirected to multiple destinations and users, including plumbing and property management services. The system can be readily installed in conventional single and dual sump pump installations without modification to the pump mechanisms, or the physical construction of the pump reservoir or associated plumbing. Moreover, the system is the completely fail safe in that the monitored pumps will continue to operate in a normal manner in the event of removal or complete inoperability of the test and monitoring system.

[082] The foregoing detailed description has been given for clearness of understanding only and no unnecessary limitations should be understood therefrom. It will be apparent to those skilled in the art, that changes and modifications may be made therein without departing from the invention in its broader aspects, and, therefore, the intent in the appended claims is to cover all such changes and modifications that fall within the true spirit and scope of the present disclosure.

CLAIMS

1. An automated system for monitoring and testing a sump pump installation of the type having a liquid container, a motor driven pump positioned within the container which when powered discharges liquid from the container, and a switch circuit which supplies current to power the pump motor upon the liquid level in the container having risen to a first predetermined level, the monitoring system comprising:

a liquid conduit including an electrically-actuated valve which admits liquid to the liquid container in response to a valve control signal;

a test control module which when actuated supplies a valve control signal to initiate a test cycle during which liquid is admitted to the container to cause the liquid level in the container to rise to at least the first predetermined level, after which the pump discharges liquid from the container until a predetermined event terminates the test cycle; and

wherein the test control module further includes an indicator circuit which indicates in response to completion of the test cycle whether the test was successful or unsuccessful.

2. A monitoring system as defined in claim 1 wherein the indicator circuit provides a visual indication of a successful test.

3. A monitoring system as defined in claim 2 wherein the visual indication comprises at least the lighting of a green indicator.

4. A monitoring system as defined in claim 1 wherein the test control module terminates supplying the valve control signal upon the liquid level in the container having risen to a second predetermined level to prevent further flow of liquid through the liquid conduit to the container.

5. A monitoring system as defined in claim 4 wherein the indicator circuit indicates in response to the liquid level in the container rising to the second predetermined level the occurrence of an unsuccessful test.

6. A monitoring system as defined in claim 5 wherein the indicator circuit provides a visual indication of an unsuccessful test.

7. A monitoring system as defined in claim 6 wherein the visual indication comprises at least the lighting of a red indicator.
8. A monitoring system as defined in claim 1 wherein the predetermined event to terminate the test cycle is the liquid level in the container having fallen to a third predetermined level.
9. A monitoring system as defined in claim 1 wherein the predetermined event to terminate the test cycle is a predetermined period of time having occurred since initiation of the test cycle.
10. A monitoring system as defined in claim 1 further including an event timer which periodically actuates the test control module.
11. A monitoring system as defined in claim 10 wherein the event timer actuates the test control module following the passage of a predetermined time interval after the pump most recently having discharged liquid from the sump container.
12. A monitoring system as defined in claim 1 wherein the indicator circuit provides a further visual indication of the valve being actuated to supply liquid to the sump container.
13. A monitoring system as defined in claim 12 wherein the visual indication comprises at least the lighting of an amber indicator.
14. An automated system for testing and monitoring a sump pump installation of the type having a liquid container, a motor driven pump positioned within the container which when powered discharges liquid from the container, and a switch circuit which supplies current to power the pump motor upon the liquid level in the container having risen to a first predetermined level, the monitoring system comprising:
 - a liquid conduit including an electrically-actuated valve which admits liquid to the container in response to a valve control signal;
 - a test control module which when actuated supplies a valve control signal to initiate a test cycle during which liquid is admitted to the container to cause the liquid level therein to rise to at least the first predetermined level, after which the pump, if functioning, discharges liquid from the container until a predetermined event terminates the test cycle;

wherein the test control module further includes an indicator circuit which, in the event of the pump being functional, indicates upon completion of the test cycle the occurrence of a successful test; and

wherein, in the event of the pump being nonfunctional, the indicator circuit indicates in response to the liquid level in the container having continued to rise the occurrence of an unsuccessful pump test.

15. A monitoring system as defined in claim 14 wherein the indicator circuit provides a first visual indication of a successful test, and a second visual indication different from the first visual indication of an unsuccessful test.

16. A monitoring system as defined in claim 15 wherein the first visual indication comprises at least the lighting of a green indicator, and wherein the second visual indication comprises at least the lighting of a red indicator.

17. A monitoring system as defined in claim 14 wherein the test control module terminates the valve control signal upon the liquid level in the container having risen to a second predetermined level to prevent further inflow of liquid to the container through the liquid conduit.

18. A monitoring system as defined in claim 14 wherein the indicator circuit provides a further visual indication of the valve being actuated to supply liquid to the sump container.

19. A monitoring system as defined in claim 18 wherein the visual indication comprises at least the lighting of an amber indicator.

20. A monitoring system as defined in claim 14 wherein the predetermined event to terminate the test cycle is the liquid level in the container having fallen to a third predetermined level.

21. A monitoring system as defined in claim 14 wherein the predetermined event to terminate the test cycle is a predetermined period of time having occurred since initiation of the test cycle.

22. A monitoring system as defined in claim 14 further including an event timer which periodically actuates the test control module.

23. A monitoring system as defined in claim 22 wherein the event timer actuates the test control module following the passage of a predetermined time interval after the pump most recently having discharged liquid from the sump container.

24. An automated system for testing and monitoring a sump pump installation of the type having a liquid container, a motor driven pump which following activation operates until subsequently deactivated by a predetermined control effect to pump liquid from the container, and a pump switch circuit which supplies current to the pump motor to activate the pump upon sensing the liquid level in the container having risen to a first predetermined level, the system comprising:

a liquid conduit connected to an external liquid source and including an electrically-actuated valve which when open flows liquid from the external source into the container;

a test control module which when actuated opens the electrically-actuated valve to initiate a test cycle during which liquid flows into the container to cause the liquid level therein to rise to at least the first predetermined level, after which the motor driven pump is activated to pump liquid from the container and the test control module closes the valve to terminate the flow of liquid into the container, the pump continuing to operate until occurrence of the predetermined control effect; and

wherein the test control module further includes an indicator circuit which indicates a successful test upon deactivation of the pump.

25. An automated system for testing and monitoring a sump pump installation of the type having a liquid container, a motor driven pump which following activation operates until subsequently deactivated by a predetermined control effect to pump liquid from the container, and a pump switch circuit which activates the pump by supplying operating current to the pump motor upon sensing the liquid level in the container having risen to a first predetermined level, the system comprising:

a liquid conduit connected to an external liquid source and including an electrically-actuated valve which opens to flow liquid from the external source into the container in response to an applied valve control signal;

a test control module which when actuated applies a valve control signal to the electrically- actuated valve to open the valve to initiate a test cycle during which liquid flows into the container to cause the liquid level therein to rise to at least the first predetermined level, after which the pump switch circuit supplies current to the pump motor to activate the pump to pump liquid from the container, and the test control module closes the valve to terminate the flow of liquid into the container, the pump switch circuit continuing to supply current to the pump motor causing the pump to continue to operate until occurrence of the predetermined control effect;

wherein the test control module includes a current sensor circuit sensing current supplied to the pump motor by the pump switch circuit; and

wherein the test control module further includes an indicator circuit which, in response to the current sensor sensing the termination of current flow to the pump motor, indicates the occurrence of a successful test.

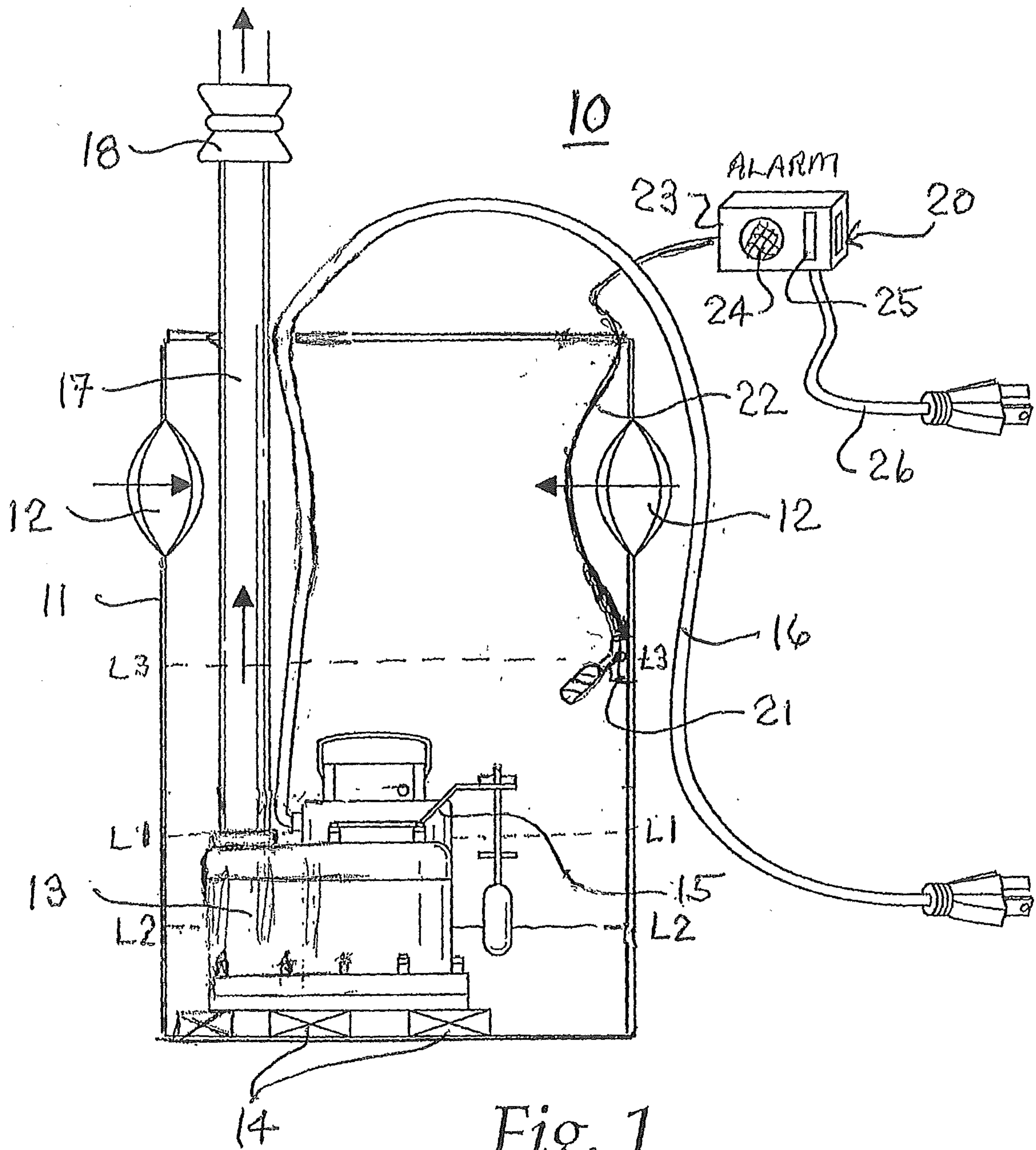
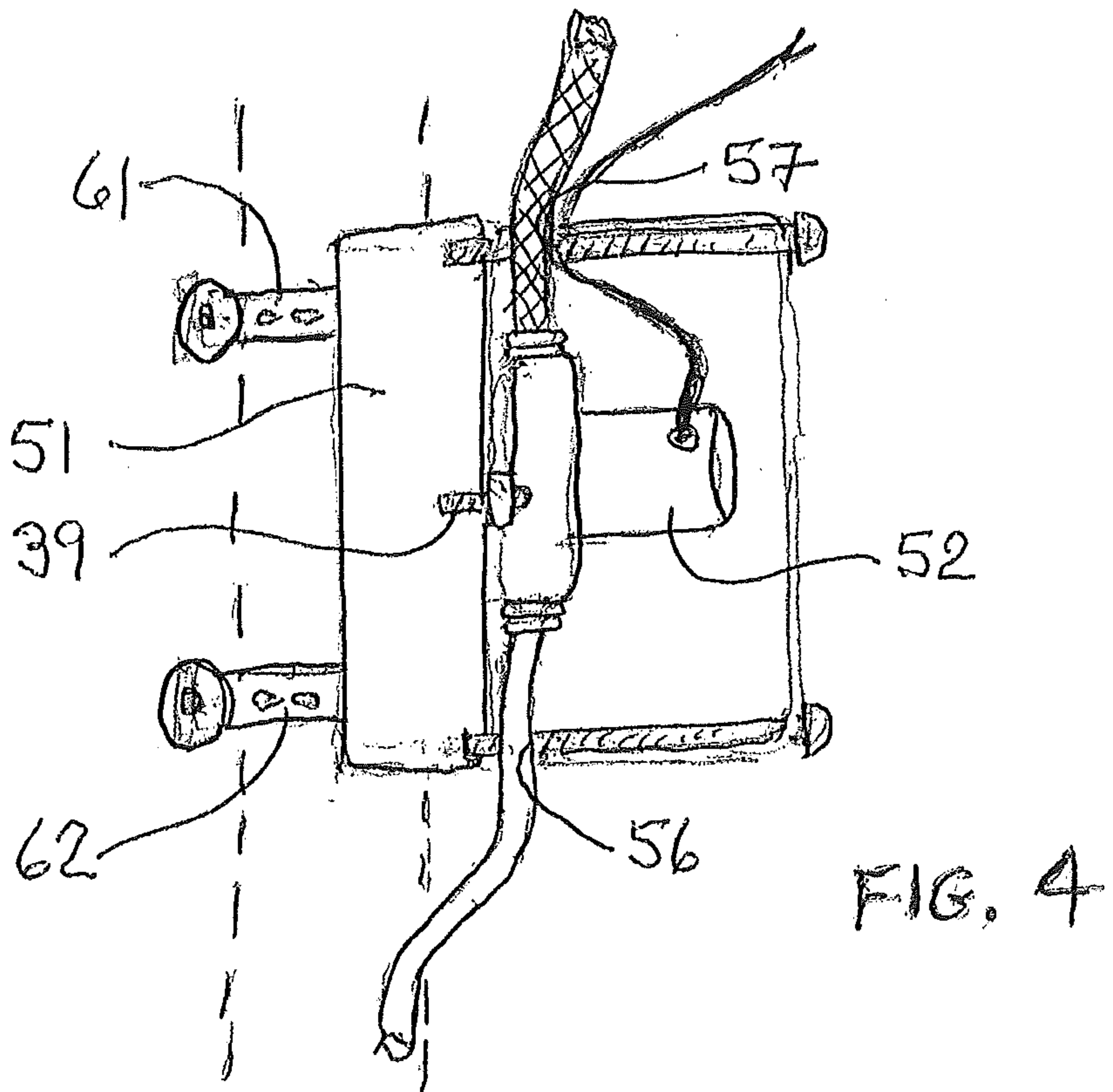
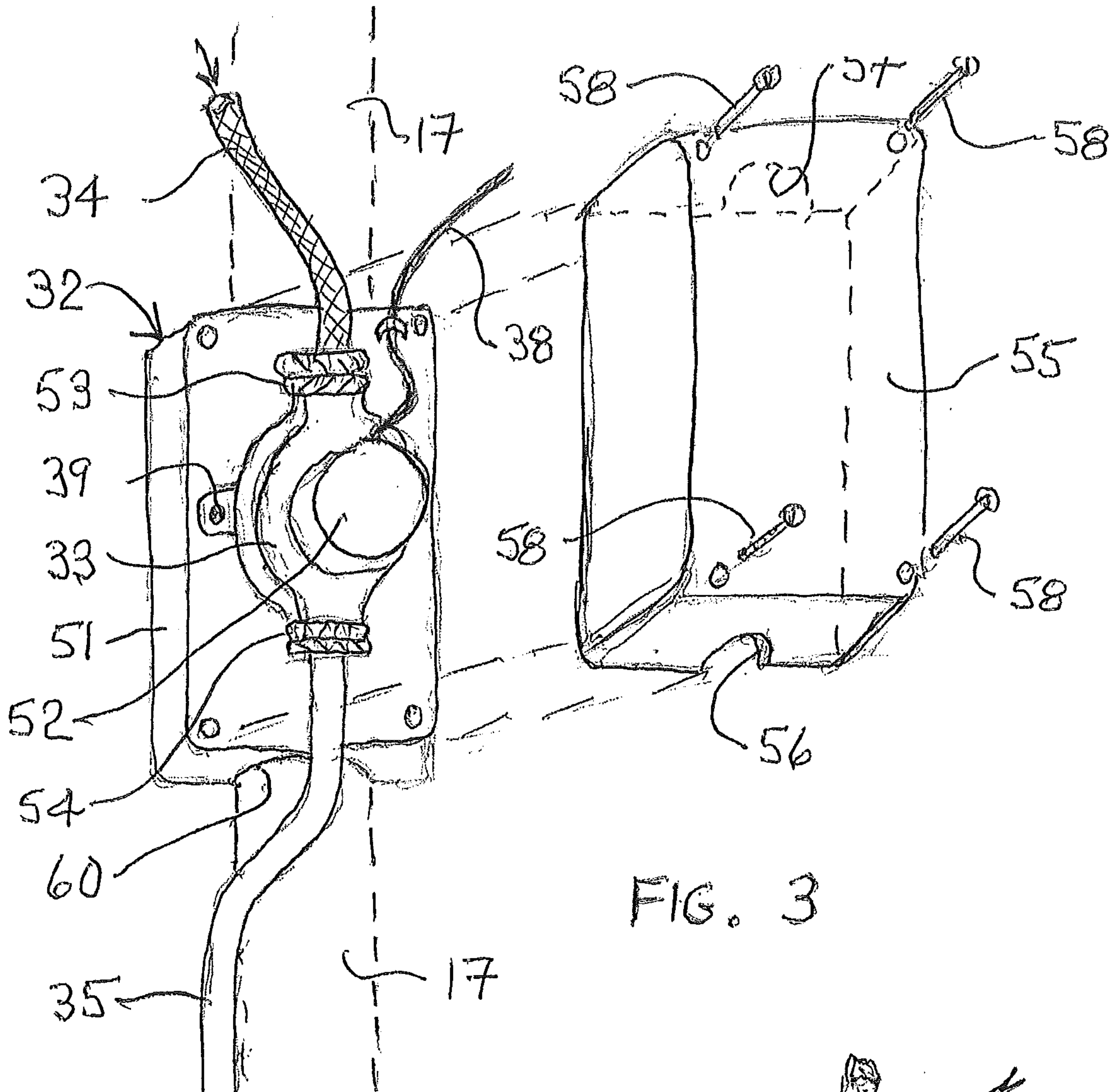

Fig. 1
Prior Art



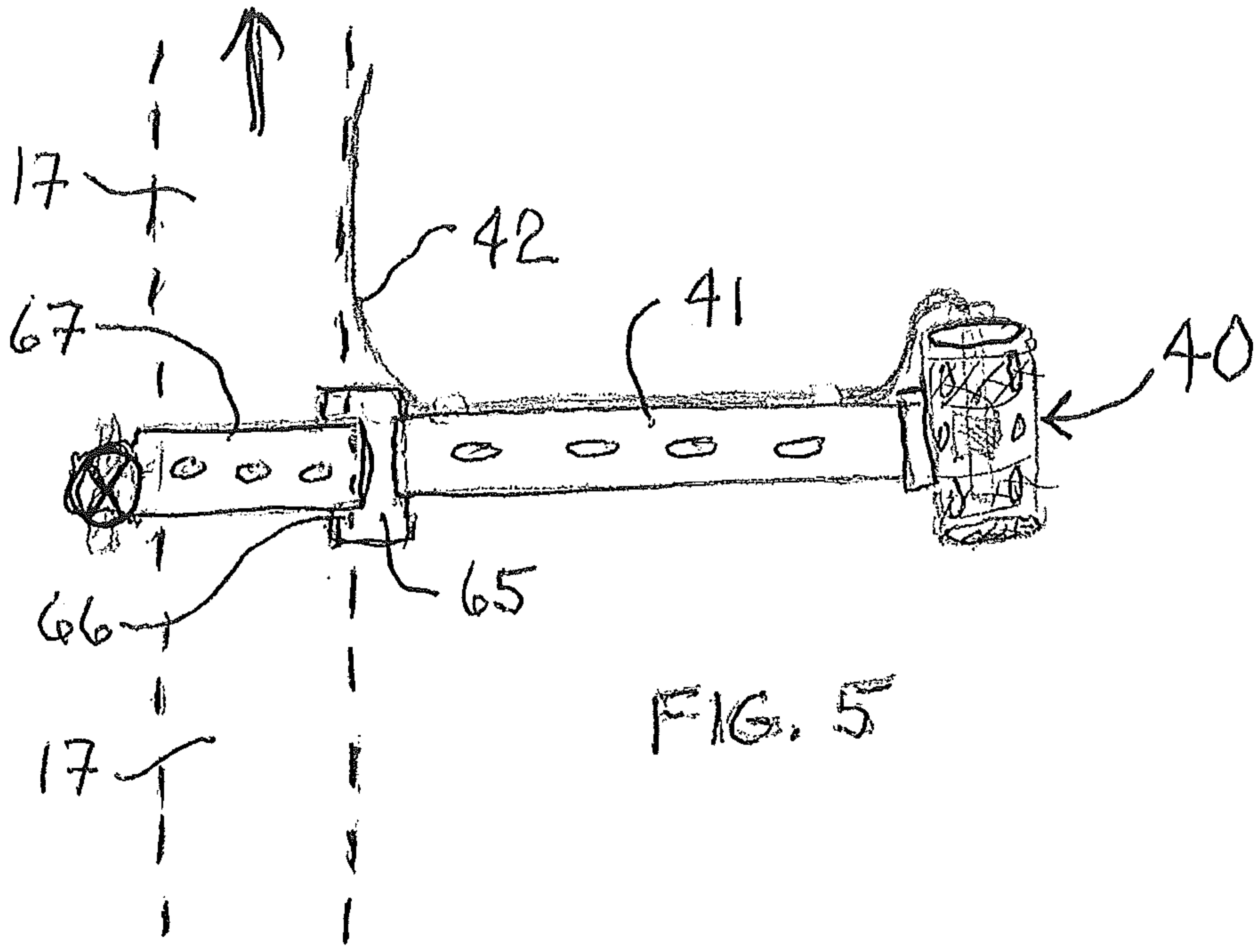

FIG. 5

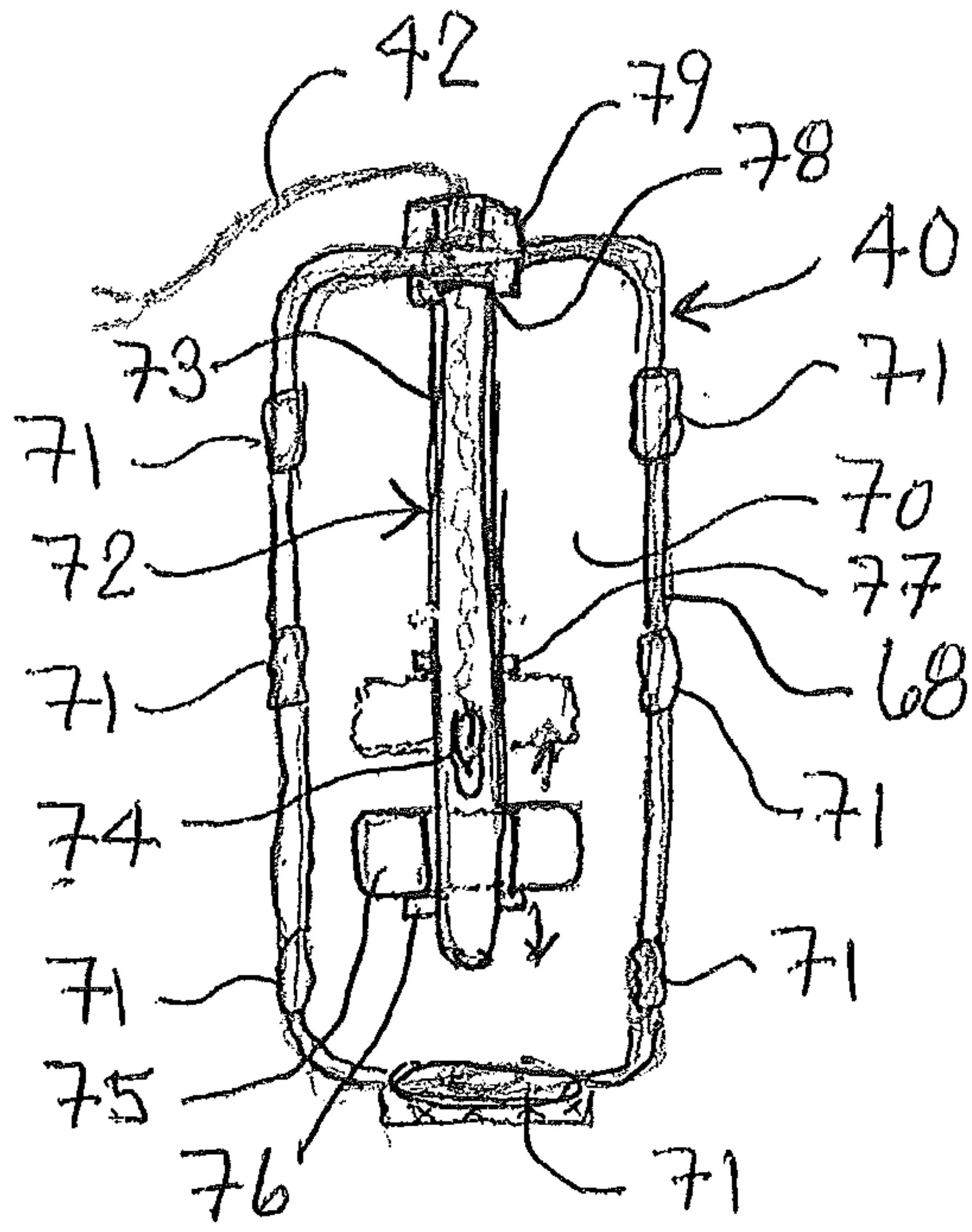

FIG. 6

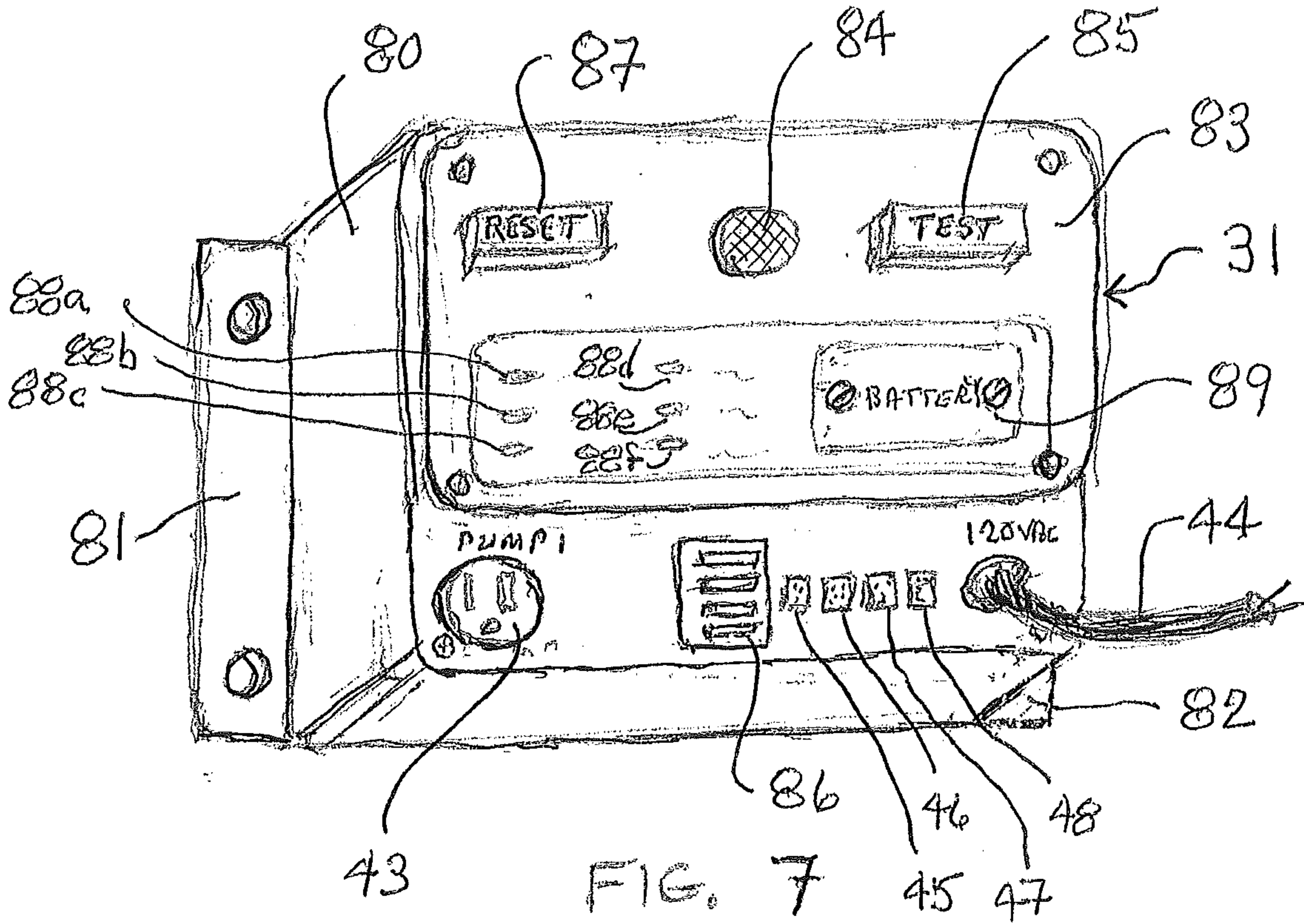

FIG. 7

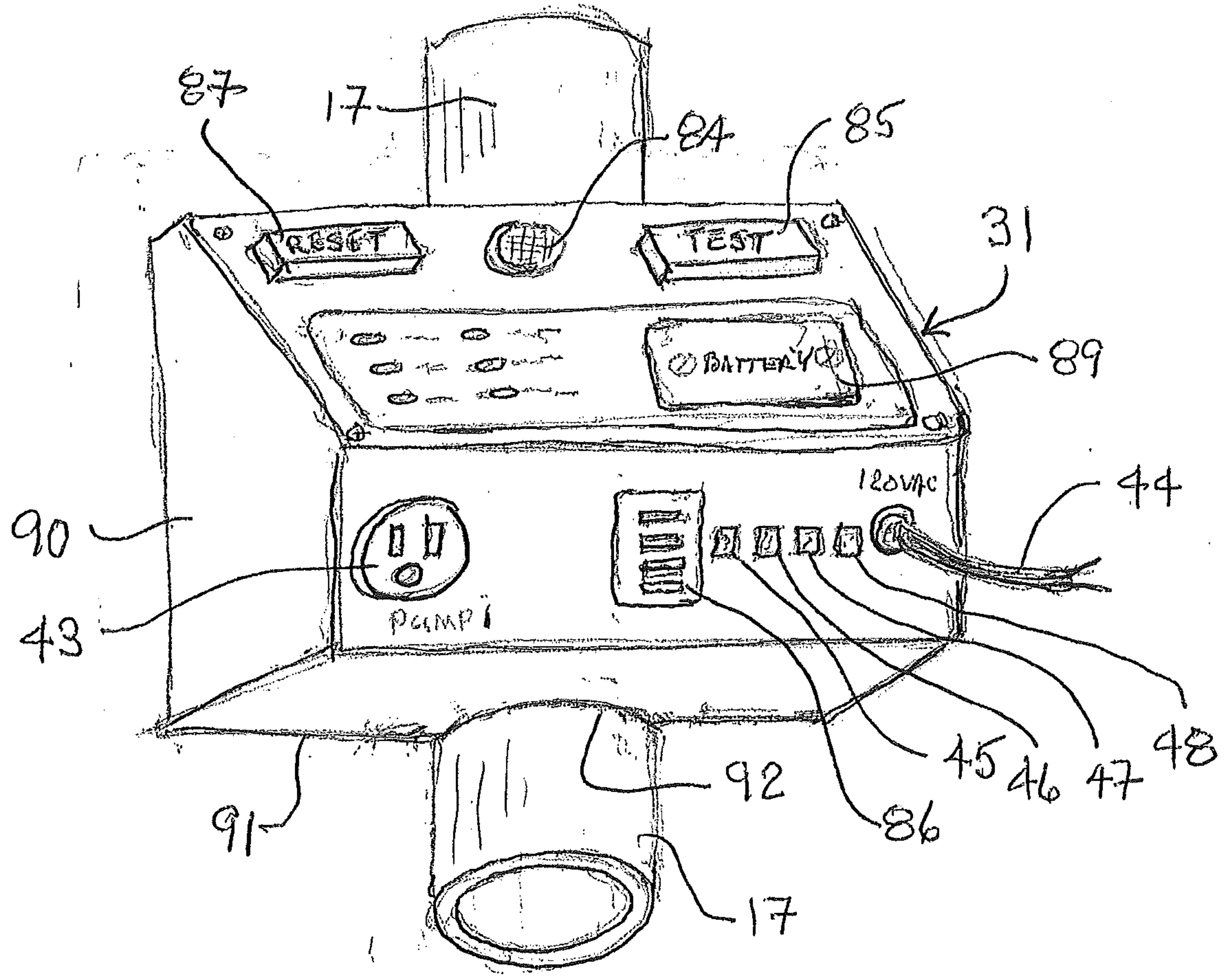

FIG. 8

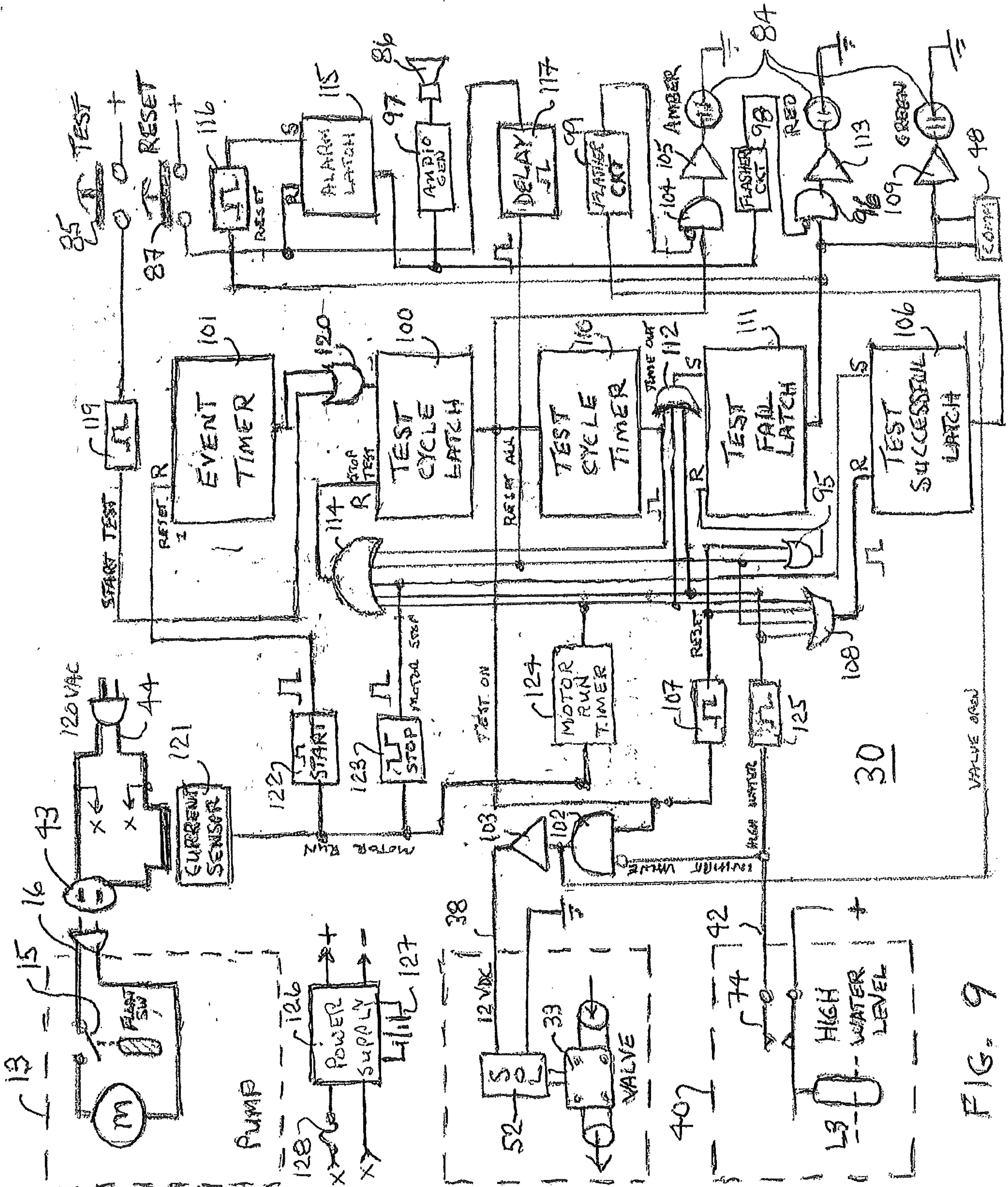

FIG. 9

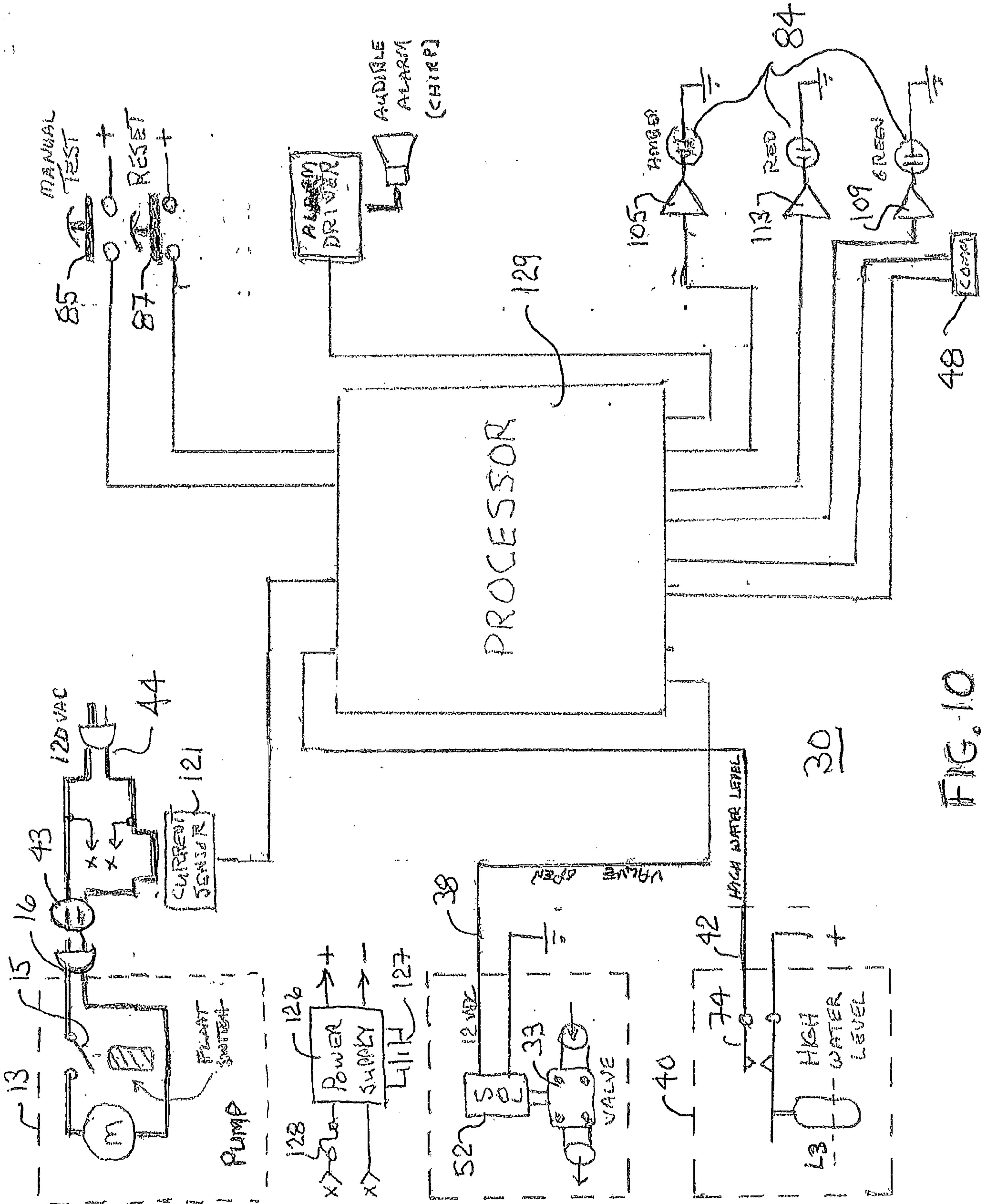

FIG. 10

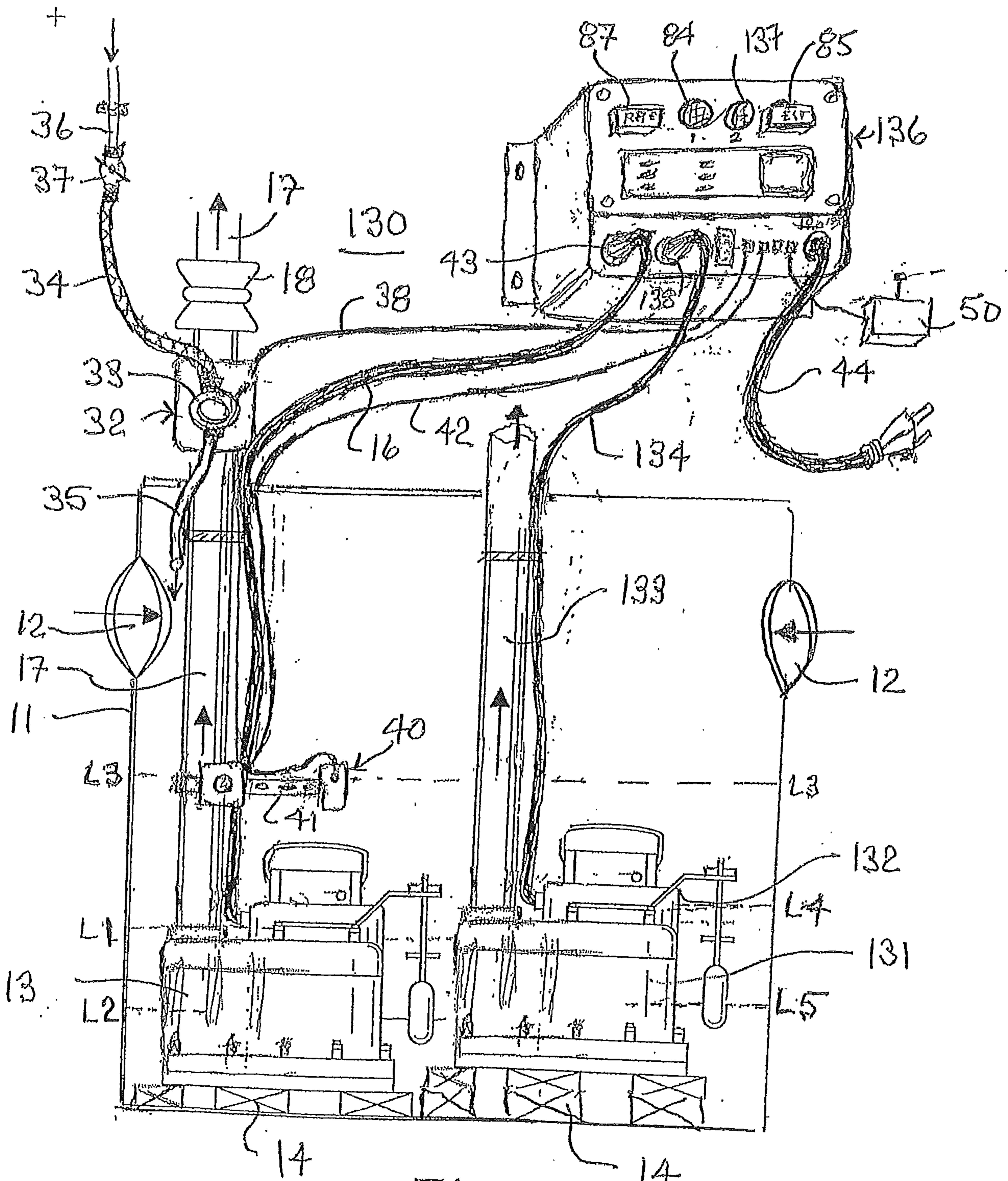

Fig. 11

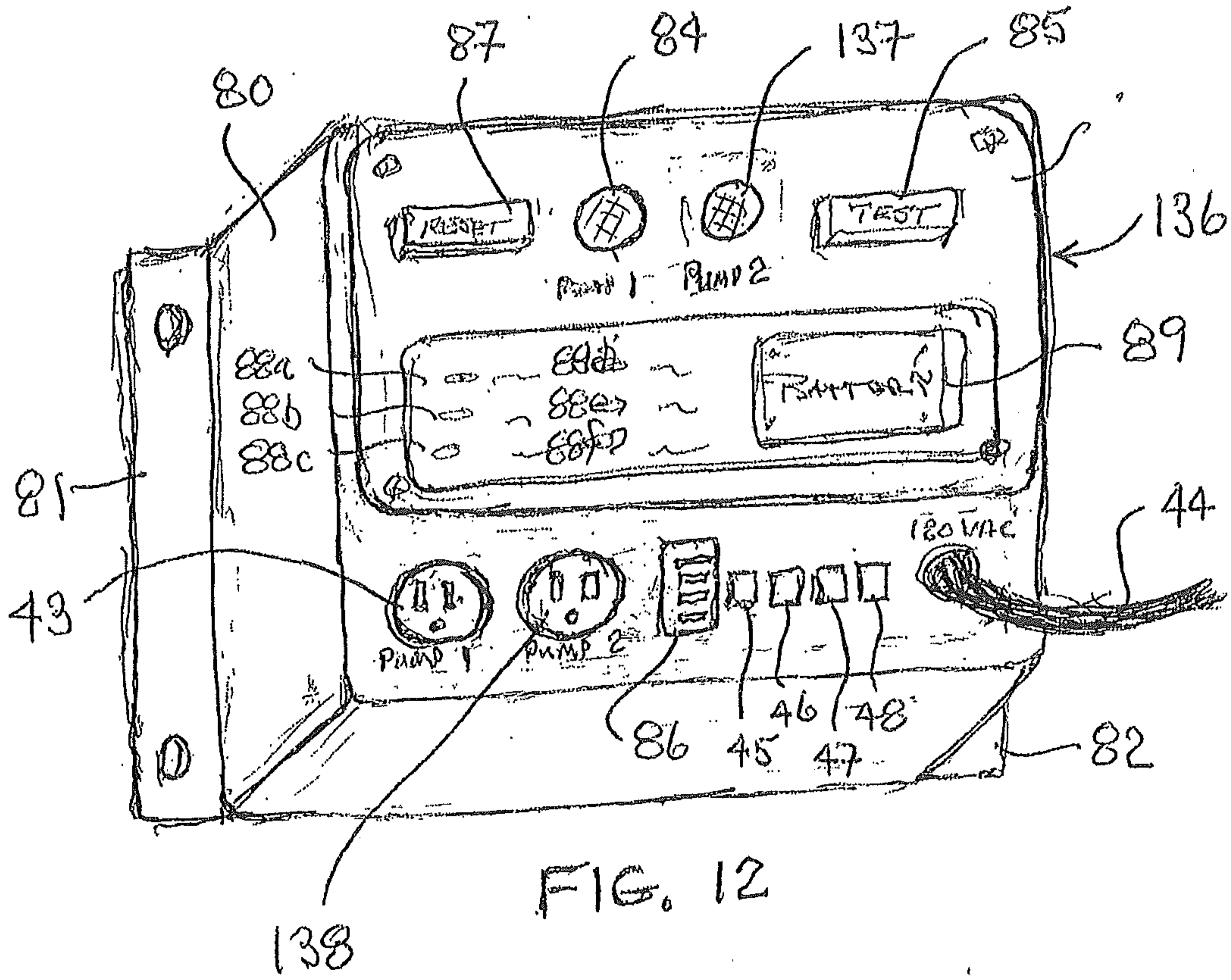

FIG. 12

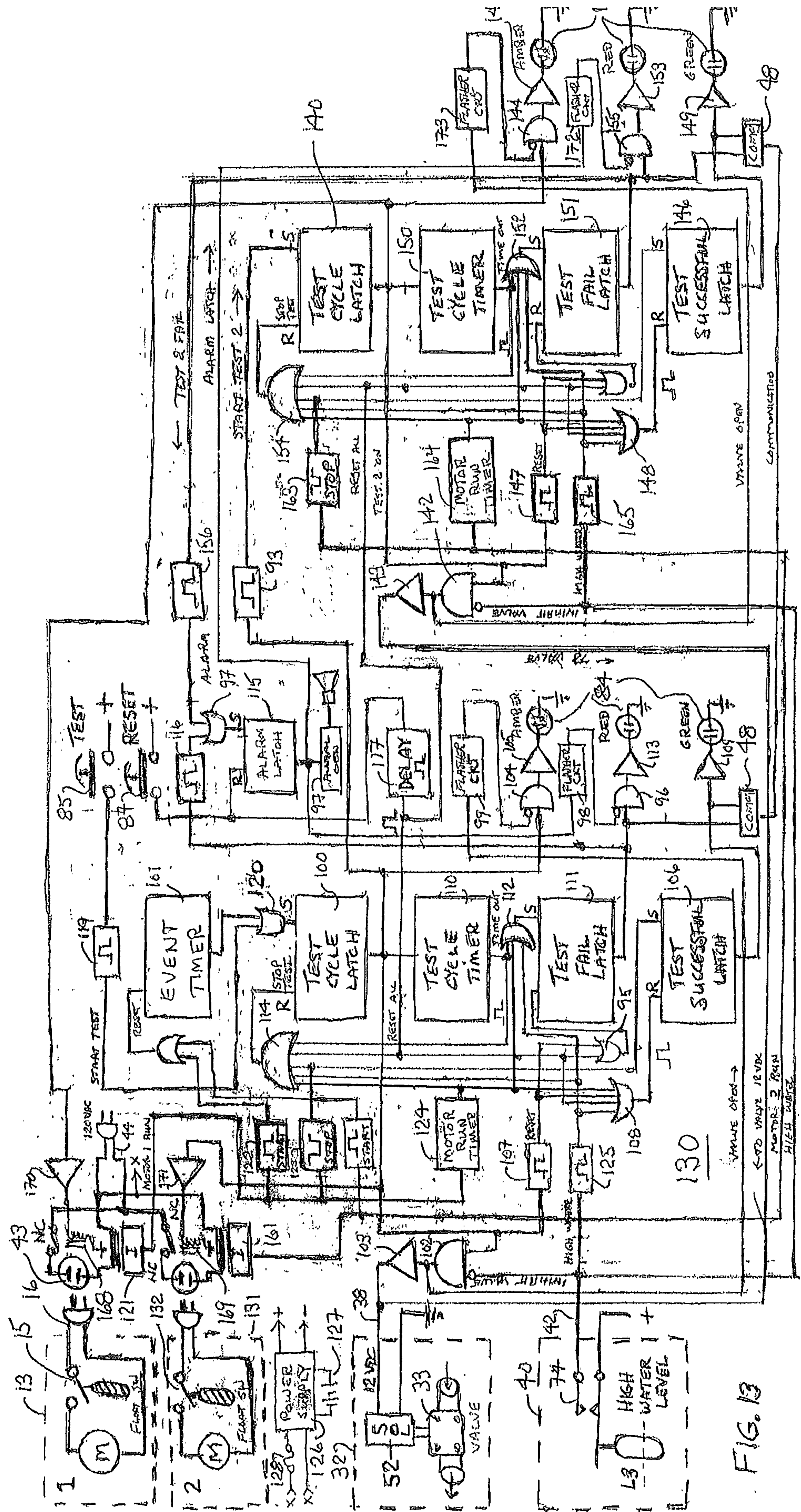

FIG. 13

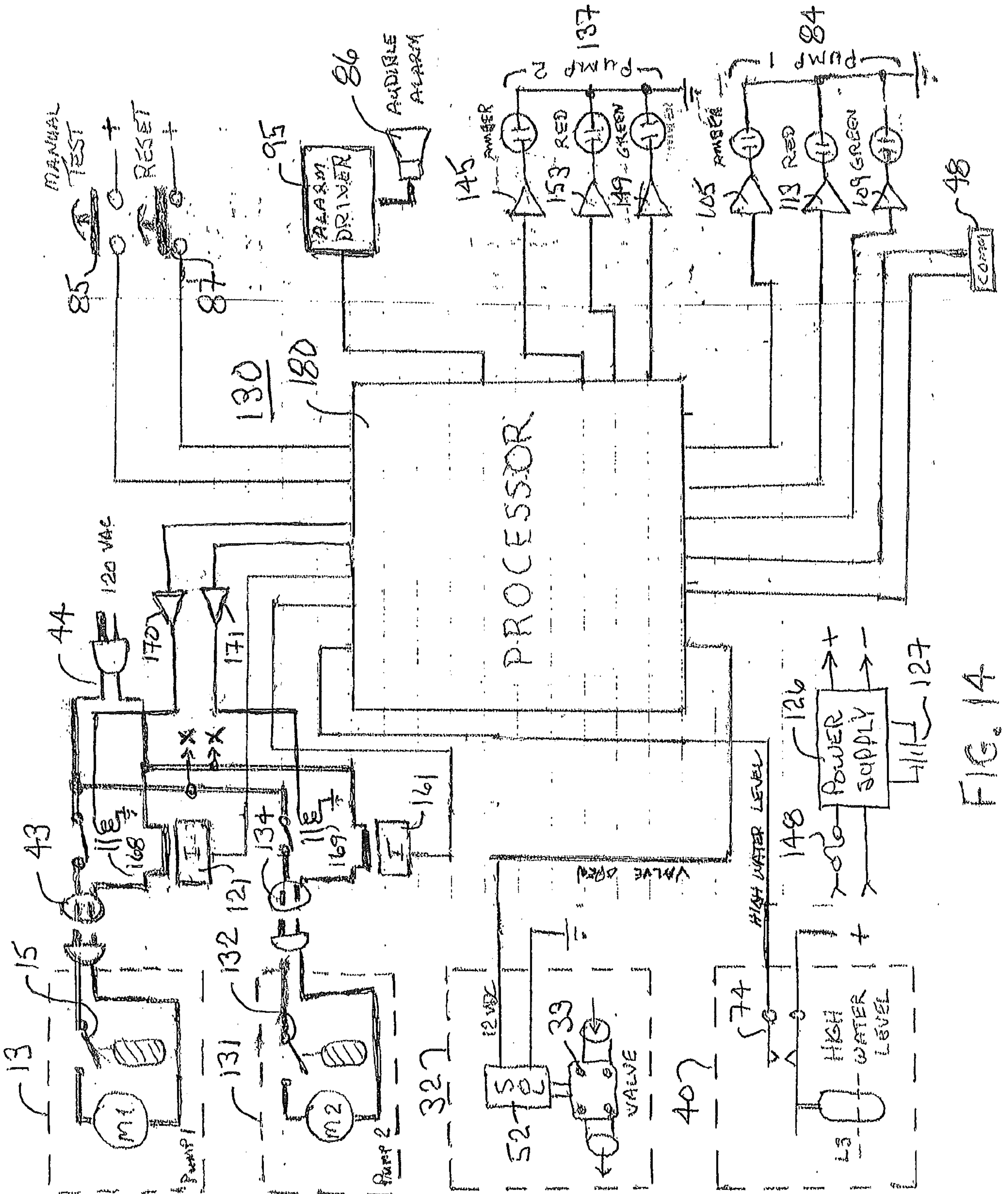

FIG. 14

