

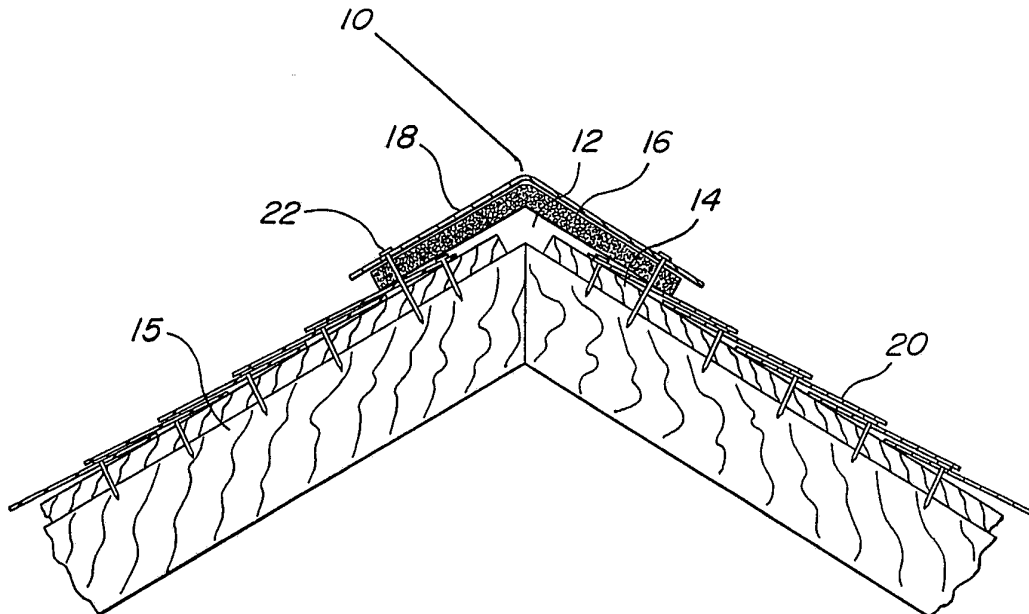

INTERNATIONAL APPLICATION PUBLISHED UNDER THE PATENT COOPERATION TREATY (PCT)

<p>(51) International Patent Classification ⁵ : F24F 7/02</p>	<p>A1</p>	<p>(11) International Publication Number: WO 93/04323 (43) International Publication Date: 4 March 1993 (04.03.93)</p>
<p>(21) International Application Number: PCT/US92/06658 (22) International Filing Date: 7 August 1992 (07.08.92) (30) Priority data: 745,573 15 August 1991 (15.08.91) US (60) Parent Application or Grant (63) Related by Continuation US 745,573 (CIP) Filed on 15 August 1991 (15.08.91) (71)(72) Applicant and Inventor: ROTTER, Martin, J. [US/US]; 115 Lismore Avenue, Glenside, PA 19038 (US).</p>		<p>(74) Agent: MARSHALL, John, J.; Seidel, Gonda, Lavorgna & Monaco, Suite 1800, Two Penn Center Plaza, Philadelphia, PA 19102 (US). (81) Designated States: CA, FI, US, European patent (AT, BE, CH, DE, DK, ES, FR, GB, GR, IE, IT, LU, MC, NL, SE). Published <i>With international search report.</i></p>

(54) Title: ROOF VENT OF SYNTHETIC FIBER MATTING



(57) Abstract

A roof ridge venting system (10) using a mat (16) constructed of randomly aligned synthetic fibers which are joined by phenolic or latex binding agents and heat cured to provide an air-permeable mat with a varying mesh. The mat is a unitary sheet construction having no dissimilar sheets laminated or otherwise bonded together. In an alternative embodiment for use with heavier slate or terra cotta tiles, the mat includes a grid pattern of small solid cores (28) extending through the thickness of the mat.

FOR THE PURPOSES OF INFORMATION ONLY

Codes used to identify States party to the PCT on the front pages of pamphlets publishing international applications under the PCT.

AT	Austria	FI	Finland	MN	Mongolia
AU	Australia	FR	France	MR	Mauritania
BB	Barbados	GA	Gabon	MW	Malawi
BE	Belgium	GB	United Kingdom	NL	Netherlands
BF	Burkina Faso	GN	Guinea	NO	Norway
BG	Bulgaria	GR	Greece	NZ	New Zealand
BJ	Benin	HU	Hungary	PL	Poland
BR	Brazil	IE	Ireland	PT	Portugal
CA	Canada	IT	Italy	RO	Romania
CF	Central African Republic	JP	Japan	RU	Russian Federation
CG	Congo	KP	Democratic People's Republic of Korea	SD	Sudan
CH	Switzerland	KR	Republic of Korea	SE	Sweden
CI	Côte d'Ivoire	LI	Liechtenstein	SK	Slovak Republic
CM	Cameroon	LK	Sri Lanka	SN	Senegal
CS	Czechoslovakia	LU	Luxembourg	SU	Soviet Union
CZ	Czech Republic	MC	Monaco	TD	Chad
DE	Germany	MG	Madagascar	TG	Togo
DK	Denmark	MI	Mali	UA	Ukraine
ES	Spain			US	United States of America

-1-

ROOF VENT OF SYNTHETIC FIBER MATTING5 Field of the Invention

This invention is related to the general field of roof ventilation systems. It is particularly related to roof ridge ventilators.

10 Background of the Invention

It has been a long known practice to ventilate attics under gable roofs by running a vent along the roof ridge. Such vents are created during construction by sizing the uppermost row of sheeting panels to leave an open slot running along the ridge essentially the length of the roof. The slot creates effective heat ventilation by convection flow and suction caused by wind across the roof ridge.

Soffit ventilators are perforated or louvered openings in the underside (soffit) of the eaves of an overhanging roof. The vents allow fresh ambient air to flow into the attic to equalize attic temperature and pressure with the outside. This equalization inhibits moisture from condensing on insulation and wood roofing materials which causes mildew and rot, prevents build-up of ice dams which could buckle shingles and gutters, and reduces air-conditioning costs when hot attic air is replaced by cooler ambient air.

A soffit ventilation system works in conjunction with a ridge vent to provide passive ventilation. As hot stale air is withdrawn from the ridge slot vent by convection and/or wind suction, it is replaced by fresh

ambient air through the soffit vents.

Differences between the various types of ridge vents have been primarily in the capping structures used over the vent slot to exclude water and pests. Early capping
5 structures were often metal hoods, or "ridge caps", extending wider than the slot and having some combination of baffles and screens to exclude water and insects. Representative examples may be seen in United States patents 2,214,183 (Seymour) and 2,160,642 (Bumpas). More
10 advanced ridge caps have used louvers, as seen in patents 3,683,785 (Grange) and 4,558,637 (Mason).

Other capping structures place some type of porous material over the slot, which is then covered by the same roofing material as the rest of the roof, such as
15 shingles or tiles. For example, patent 3,949,657 (Sells) shows using a matrix of either molded plastic or corrugated cardboard dipped in epoxy as the porous material, with shingles nailed over the matrix leaving the side edges open to vent hot air. The relatively
20 large size and straight line orientation of the pores in this corrugated material apparently permitted wind-driven rain to back flow into the slot, as it has since been found an improvement to include a metal flashing strip with small vent holes at least on the windward side
25 (patent 4,843,953, again Sells). Essentially similar is the corrugated polyethylene sheet material shown in patent 4,803,813 (Fiterman).

Materials having smaller and more convoluted air passages than the corrugated materials provide a more
30 effective barrier against wind-driven water and small insects. Non-woven fiber mats and open-cell plastic foam are inexpensive materials of this description which have been used in roof ventilators. In patent 4,325,290 (Wolfert), a non-woven fiber mat is used as a filter in
35 a vent cap system. In patent 4,942,699 (Spinelli), a thin non-woven fiber sheet is bonded to matting of nylon filaments to provide sufficient structural resilience to

allow the sheet to be used under shingles. In patent 4,876,950 (Rudeen), two strips of open-cell plastic foam are joined to an impermeable plastic membrane again two parallel for use under shingles.

5 It is apparent from the above that inventions in the field of roof ridge vents have largely evolved from the availability of new materials, and the ingenuity of inventors in adapting such materials for venting. Without attempting to provide a exhaustive listing of
10 desirable properties, it can generally be observed that a venting material must be sufficiently air-permeable to provide heat ventilation, but still prevent the entry of small insects, dust, and water. Consequently, materials having small convoluted air passages and non-wicking
15 characteristics, such as non-woven fiber sheets and open-cell foam, are good candidates. But such materials should also demonstrate other mechanical and chemical properties such as tensile strength, resilience, ability to be transported in rolls and cut to length, ease of
20 joining strips, and long term durability in local ambient conditions.

With prior vent systems, as described above, these additional properties have been achieved by laminating fiber sheets or foam strips to other materials, such as
25 nylon matting (Spinelli) or plastic membrane (Rudeen). However, such composite materials frequently compromise some features in order to achieve others. For example, the lamination of nylon matting to the fiber sheet, as described in the Spinelli patent, gives the sheet a
30 needed thickness and resilience, but complicates its ease of application. When the laminated material is unrolled for installation, the nylon matting must be cut back from the edge at the ends and sides, and the non-woven fiber sheet wrapped up around the sides of the matting to
35 create a barrier against water and insects. To join two strips of the laminated material, the nylon matting must also be cut away on one sheet, and the two sheets then

lapped and joined by adhesive. Moreover, even though the matting is bonded to the sheet on either side of a central hinge line, it is possible for workmen unfamiliar with the material to install it upside down; that is, with the sheet side over the matting, instead of underneath it. The potential for this error can be seen by comparing the nylon matting laminated material (Spinelli) to the plastic membrane material (Rudeen); the former is installed with the nylon matting side down, while the latter is installed with the plastic membrane up. A worker experienced with only one of these materials could easily be led by his experience to install the other inverted.

15 Summary of the Invention

The present invention provides an improved roof ridge venting system using a mat constructed of randomly-aligned synthetic fibers which are joined by phenolic or latex binding agents and heat cured to provide an air-permeable mat with a varying mesh. In contrast to other vent matting, the mat of the present invention is a unitary sheet construction having no dissimilar sheets laminated or otherwise bonded together.

Under a standard compression test of 1360 grams, a preferred standard embodiment of the mat which is only 5/8th inch thick exhibits a compression of 13% and a recovery of 100%. Tensile strength is 55 psi in the long direction and 64 psi in the cross direction. Such mat provides a simplified method of installation in that it can simply be cut to length from a roll and installed over the ridge slot, with the capping shingles or tiles nailed on top of it. If it is necessary or desirable to join sections of the material, such joiner can be made by merely coating the abutting ends to be joined with synthetic rubber sealant used for bonding asphalt shingles and sealing around flashing, or any other suitable caulk or adhesive.

An alternative embodiment of the mat is provided for use with unusually heavy roofing tiles such as slate or terra cotta, where greater compression resistance is needed. This increased compression resistance is achieved by injecting drops of liquid polyester (nylon) into the fiber mat in a grid pattern to create a grid of solid cores approximately 1/2-inch in diameter at approximately 3-inch grid spacing. The dispersed pattern of cores supports the heavier tiles without hampering ventilation or the ability of the mat to be supplied on a roll.

Brief Description of the Drawings

For the purpose of illustrating the invention, the drawings show a form which is presently preferred; it being understood, however, that this invention is not limited to the precise arrangements and instrumentalities shown.

Figure 1 is a sectional view taken at the ridge of a roof, showing a ridge vent using a unitary mat according to the present invention.

Figure 2 is a perspective view of a partially-installed roof ridge vent according to the present invention.

Figure 3 is a perspective view of two strips of mat material being joined end-to-end to install a roof vent according to the present invention.

Figure 4 is perspective view of a roll of an alternative embodiment of mat material which has a grid of solid cores for use with heavy tiles.

Figure 5 is a section view along the line and in the direction of the arrows 5-5 of Figure 4.

Description of the Preferred Embodiment

In Figure 1, a venting system 10 according to the invention is used to vent hot air from an attic through a slot 12 in the ridge of a roof. In original
5 construction, the slot 12 is formed by cutting the upper row sheeting panels 14 approximately 3/4 to 1 inch short of the ridge crest formed by the rafters 15 in a roof truss, as shown in Figure 1 (1-3/4 to 2 inches if a ridge pole is used). In existing structures, the slot can be
10 formed by cutting away the same size strip from the sheeting at the ridge on both sides, taking care not to damage the rafters or a ridge pole, and terminating about six inches from the front and back sides of the roof.

As known to those in the art, a vent along the ridge
15 of a gable roof is effective in drawing hot stale air out of the interior space covered by the roof, usually an attic. Convection flow draws the highest temperature air to the ridge crest and out the vent. Wind across the vent line is directed up and over the vent by the sloping
20 sides of the roof, creating a lowered pressure at the vent which draws air out of the attic even when there is little convection current. When combined with soffit vents under the eaves to draw fresh air, a ridge vent usually provides more effective attic ventilation than
25 turbine vents or large vent cans. However, the effectiveness of the vent depends upon the degree to which convection outflow and wind across the vent line is uninhibited by the vent structure. Most effective would be a completely uncovered vent, but the need to
30 keep out rain water, dirt and pests requires some sort of covering structure. The design considerations for a covering structure are, therefore, to maximize convection outflow and wind suction, establish an effective barrier against water, dirt and insect entry, maintain aesthetic
35 appearance and long term durability, while providing low cost and ease of installation.

The present invention meets these design parameters

by providing a unitary mat 16 made of randomly aligned synthetic fibers joined by phenolic or latex binding agents and heat cured to provide a mat with an air permeable varying mesh. Under a standard compression test of 1360 grams, a preferred standard embodiment of the mat which is only 5/8th inch thick exhibits a compression of 13% and a recovery of 100%. Tensile strength is 55 psi in the long direction and 64 psi in the cross direction.

10 As used herein, the term "unitary" is intended to mean that the mat material is of unitary sheet construction, rather than dissimilar sheets laminated or otherwise bonded together. It does not exclude joining strips of the material with roofers caulk or other
15 adhesive as described in subsequent paragraphs.

The mat 16 is a continuous strip preferably about 10-1/2 inches wide and 5/8th inch thick. It thus runs the length of the slot, overlapping the slot evenly on each side 12, and is of such low profile that it does not
20 attract attention when covered by shingles or tiles of the same color and texture as used on the rest of the roof, such as cap shingle 18 of Figure 1.

Roof shingles 20 are laid in overlapping rows in the conventional manner up to the slot 12. As depicted in
25 Figures 1 and 2, the mat 16 may easily laid by unwinding one end of the material from a roll and centering it over the slot at one end, then unrolling it in a continuous strip to the other end where it is cut from the roll. Starting from one end and working to the other, each cap
30 shingle 18 is then laid over the mat 16 and overlaps the edge of the preceding cap shingle, and secured by driving roofing nails 22 through the cap shingle 18, mat 16 and roof shingle 20 into the underlying sheeting 14 and rafters 15.

35 The mat 16 is sufficiently resistant to compression that the installer can easily feel when the shingle 18 is pressed firmly against the mat, and sink the nail 20

only until the nail head is against the shingle, leaving the cap raised about 5/8 inch above the underlying roof shingles. At most lines of sight and distances on the ground around the building, the 5/8 inch rise is
5 indistinguishable from the surface of the roof. Further, the low profile of the vent does not significantly disrupt wind current across the ridge line, which promotes the lowered pressure at the vent exits and resulting suction of attic air through the vent.

10 The mat 16 provides a simplified method of installation in that it can simply be cut to length from a roll and installed over the ridge slot, with the capping shingles or tiles nailed on top of it. If it is necessary or desirable to join strips of the material,
15 such joinder can be made by merely coating the abutting ends with synthetic rubber sealant used for bonding asphalt shingles and sealing around flashing, or any other suitable caulk or adhesive, and abutting the strips end-to-end as shown in Figure 3.

20 While the above described mat has sufficient compression resistance for normal capping shingles made of asphalt or wood, an alternative embodiment of the mat may be used in applications where the roof is covered with heavy terra cotta or slate tiles, and it is desired
25 to use the same material for the vent cap. Such tiles are much heavier than normal capping shingles, and cannot be nailed through without cracking. Consequently, these tiles are installed over the mat by an adhesive rather than by nails extending through the tile and mat. The
30 mat may be tacked in place on the roof with nails or adhesive before the tiles are placed on over the mat.

The combined effect of heavy weight from roofing tiles and adhesive infiltration into the mesh may flatten and fill the normal fiber mat so much that it
35 will cause insufficient air flow. Consequently, an alternative embodiment mat 16, as depicted in Figures 4 and 5, exhibits increases compression resistance through

a grid of solid cores 28.

The cores are created by the solidification of drops of liquid polyester, herein nylon, which are injected into the fiber mat. After the basic 5/8th inch material is formed and slit into appropriate width sheets, (which could be 12 to 16 inches for the larger tiles), it is passed under a set of reciprocating injection nozzles spaced approximately three inches apart. As the mat passes, the tapered-tip nozzles descend and push through the web to the structure supporting the moving mat, and eject molten nylon as they are withdrawn upward. The liquid nylon will set almost instantly when exposed to the air and will adhere to the web material, thus creating a row of solid cores 28 which extend vertically through the mat, as shown in Figure 5.

For example, it is presently contemplated to use a nozzle system in which a representative core is a nominal 1/2-inch in diameter. The reciprocation of the nozzles is timed to the advance of the mat to create a square grid pattern at approximately 3-inch spacing, as shown in Figure 4. This grid spacing provides sufficient weight bearing to avoid over-compression of the mat, yet allows the material to be delivered on a roll and cut-to-length right on the roof.

This alternative embodiment may also be desirable for use with regular nailed shingles in climatic regions where extremely heavy snow fall may accumulate on the cap shingles and caused excessive and prolonged compression. The cores are sufficiently dispersed and at regular intervals, so that it is easy to avoid nailing through a core.

Further, as shown in Figure 4, the mat material may be provided with two lateral-edge bands 24 of adhesive coating, each band approximately 1-inch wide and running the length of the roll along a lateral edge on one of the wide faces. The bands 24 may be covered with a pull-off protective strip 26 of paper or other air-tight material

to keep the adhesive tacky and the rolled material from adhering to itself until it is used. The installer may then place mat over the vent slot with the bands 24 facing down, tear off the covering strips 26, and push 5 the mat edges against the roof shingles 20 to adhere the adhesive bands to the roof on both sides of the slot. This secures the mat to the roof while the tiles or cap shingles 18 are being placed over the mat.

The mat 16 is made of non-woven synthetic fiber mesh 10 of a type that has been used in other applications for scrubbers and polishers. Synthetic fibers (usually nylon or polyester) are opened and blended, then randomly aligned into a web by airflow in a processing machine commonly known as a Rando webber. The raw fiber web is 15 then sprayed with binding agents of water-based phenolics and latexes, and oven-cured to bind the fibers into a relatively rigid mat having a significant porous area between the random fibers. An example of such mat is M29 polyester scrubber pads made by Loren Products Division 20 of Atochem North America Inc.

The presently preferred material for mat 16 is similar to the above M29 except that aluminum oxide is substituted in the binder for the more expensive abrasive material used in scrubber pads, and the web is produced 25 as a 5/8 inch deep, 10-1/2 inch wide strip on 20 foot or 50 foot rolls. Its specifications are as follows:

	Ounce Weight (sq. yd.)	40.5 - 45.0 - 49.5
	Thickness (mm)	15.9 - 17.5 - 19.9
	Binder %	23.55- 26.17- 27.79
30	Fiber Type	Polyester
	Fiber Size	200 denier
	Fiber Percent	25.71- 28.57- 31.43
	Mineral Type	AlO ₂ (ave mesh 140)
	Mineral Percent	40.7 - 45.3 - 49.9
35	Break Machine Direction	30.0 psi minimum
	Cross Direction	30.0 psi minimum
	Tear Machine Direction	30.0 psi minimum

-11-

Cross Direction 30.0 psi minimum
 Water Penetration 30 seconds minimum

5

The mat material also has the following properties,
 as determined through ASTM and other standard tests:

	<u>Property</u>	<u>Test</u>	<u>Value</u>
10	Air permeability	ASTM D737	760 (cu.ft./min.)
	Tear Strength	ASTM D1294-86	
	Machine		42 psi.
	Counter		35.5 psi.
	Tensile Strength	ASTM D2261-83	
15	Machine		55 psi.
	Counter		64 psi.
	Self Ignition Temp.	ASTM D1929	963 deg.F
	Cold Crack Resistance	C-115	-25deg.F

20 The polyester fiber and binder material create a
 non-wicking mat, which, when installed as described
 above, is an effective barrier against wind-driven rain.
 A section of mat was subjected to a wind-driven rain test
 simulating the extreme condition of an 8 inch per hour
 25 rainfall at 100 m.p.h. wind, in which water was added to
 the airstream up-wind of a mat specimen mounted on a 3
 inch by 12 inch slopped roof. The specimen was subjected
 to incremental increased wind speeds for the periods
 noted below:

	<u>Wind Speed</u> <u>(minutes)</u>	<u>D u r a t i o n</u>
	50	5
	60	5
5	70	5
	80	1
	90	1
	100	1
		<hr style="width: 50px; margin: 0 auto;"/>
		12 minutes total

10 No damage or failure was evident and no leakage occurred.

The mat further exhibits sufficient compression resistance to provide a structural base for the cap
 15 shingles. A section of mat was subjected to a static pressure structural uplift test in which the specimen was subjected to upward acting static pressure loads of 28.5 and 57 lbs. per square foot. The mat was installed over
 20 2 inch roofing nails at about 5 inch centers for each shingle, thereby providing four nails per foot on each side of the vent. No damage or failures were observed.

The material is durable against ultra violet light deterioration which degrades most nylon and polyester
 25 fiber materials over time. A section of mat was subjected to a UV stability test in which a mat was placed within a UV chamber and subjected to constant UV exposure for 1000 hours. No significant change of properties was observed.

30 The present invention may be embodied in other specific forms without departing from the spirit or essential attributes thereof and, accordingly, reference should be made to the appended claims, rather than to the foregoing specification, as indicating the scope of the

invention.

INDUSTRIAL APPLICABILITY

The invention is expected to be used primarily in
the construction of new buildings having gable roofs, and
5 secondarily in roof replacement.

CLAIMS

I claim:

1. A roof venting system comprising:
an open slot along substantially the length of a
5 roof ridge permitting air ventilation from the interior
space to the exterior;
an air-permeable mat covering the slot over the
length of the slot and overlapping the slot on each side,
the mat being constructed of randomly aligned synthetic
10 fibers which are opened and blended, randomly aligned
into a web, joined by phenolic or latex binding agents
and heat cured to produce an air permeable varying mesh,
said mat being of unitary sheet construction and
including a grid of solid cores extending through the
15 thickness of the mat for supporting a capping structure
thereon;
a capping structure overlying the mat and spaced
away from the roof by the thickness of the mat to provide
ventilation through the mat in the space between the
20 capping structure and the roof.
2. A roof venting system as in claim 1, wherein
the capping structure comprises a plurality of roofing
tiles placed over and adhesively secured to the mat.
3. A roof venting system as in claim 2, wherein
25 the mat is approximately 5/8th inch thick.
4. A roof venting system as in claim 1, wherein
the synthetic fibers are polyester.

5. A roof venting system as in claim 4, said grid comprising said cores of approximately 1/2-inch diameter at approximately 3-inch grid spacing.

6. A roof venting system as in claim 5, said grid
5 of solid cores being formed by drops of molten polyester injected into the mat and solidified therein.

7. A roof venting system as in claim 6, wherein the mat is approximately 5/8th inch thick.

8. In a roof venting system of the type comprising
10 an open slot along a roof ridge to permit ventilation from the interior space under the roof to the exterior, an air permeable material overlying the slot to permit ventilation while excluding water and insects from entering through the slot, and capping materials covering
15 said air permeable material, the improvement comprising:

said air permeable material comprising a flexible and resilient mat constructed of a unitary sheet of randomly aligned synthetic fibers joined by phenolic or latex binding agents and heat cured, and including a grid
20 of solid cores extending through the thickness of the mat for supporting said capping materials thereon.

9. In a roof ventilating system as in claim 8, further comprising the mat having sufficient compression resistance to maintain its thickness as spacing between
25 the roof and capping materials.

10. In a roof ventilating system as in claim 9, further comprising the mat being approximately 5/8th inch thick.

11. In a roof ventilating system as in claim 10, said mat further comprising a unitary sheet of polyester fibers which are opened and blended, randomly aligned into a web, treated with binding agents and heat cured to bind the fibers into a relatively rigid mesh.

12. In a roof venting system as in claim 11, said mat including a grid of solid cores formed by drops of molten polyester injected into the fiber mat and solidified therein.

13. In a roof venting system as in claim 12, said molten polyester being molten nylon.

14. In a roof venting system as in claim 12, said grid comprising said cores of approximately 1/2-inch diameter at approximately 3-inch grid spacing.

15. In a roof venting system as in claim 8, wherein the capping structure comprises a plurality of roofing tiles, the improvement further comprising the tiles being placed over and adhesively secured to the mat.

16. For use in a roof venting system of the type comprising an open slot along a roof ridge to permit ventilation from the interior space under the roof to the exterior, an air permeable material overlying the slot to permit ventilation while excluding water and insects from entering through the slot, and capping materials covering said air permeable and resilient materials, an improved air permeable material comprising:

a flexible and resilient mat constructed of a unitary sheet of randomly aligned synthetic fibers joined

by phenolic or latex binding agents and heat cured, said mat including a grid of solid cores extending through the thickness of the mat for supporting said capping materials thereon .

5 17. The improved material of claim 16, further comprising said sheet being provided in a roll and adapted to be unrolled over the slot and cut to the desired mat length.

10 18. The improved material of claim 17, further comprising the sheet being provided with two bands of adhesive coating, each band running the length of the roll along each lateral edge of one face of the sheet, and each band covered with an air-tight pull-off strip adapted to be pulled away to expose the adhesive coating
15 after the sheet is unrolled over the slot and cut to the desired mat length.

19. The improved material of claim 21, further comprising the mat being of polyester fibers which are opened and blended, randomly aligned into a web, treated
20 with binding agents and heat cured to bind the fibers into a relatively rigid mat having a varying mesh.

20. The improved material of claim 19, further comprising said mat including a grid of solid cores formed by drops of molten polyester injected into the
25 fiber mat and solidified therein.

21. The improved material of claim 23, further comprising said grid comprising said cores of approximately 1/2-inch diameter at approximately 3-inch grid spacing.

5 22. A roof venting system comprising:

an open slot along substantially the length of a roof ridge permitting ventilation from the interior space under the roof to the exterior;

10 a mat covering the slot over the length of the slot and overlapping the slot evenly on each side, the mat being a unitary sheet of randomly aligned synthetic fibers joined by phenolic or latex binding agents and heat cured, and having an air permeable varying mesh;

15 a capping structure overlying the mat and spaced away from the roof by the thickness of the mat to provide ventilation through the mat in the space between the capping structure and the roof.

20 23. A roof venting system as in claim 22, wherein the capping structure comprises a plurality of shingles secured over the mat by nails driven through the mat into the underlying roof.

24. A roof venting system as in claim 22, wherein the mat is approximately 5/8th inch thick.

25 26. A roof venting system as in claim 22, wherein the varying mesh acts as a barrier to inhibit the entry of insects, dust, and water through the vent into the interior space under the roof.

27. In a roof venting system of the type in which an open slot along substantially the length of a roof ridge permits ventilation from the interior space under the roof to the exterior, an air permeable and resilient material overlies the slot to permit ventilation while excluding water and insects from entering through the slot and to provide spacing between the slot and capping materials, and capping materials covering said air permeable and resilient materials, the improvement comprising:

10 said air permeable and resilient material being a mat constructed of randomly aligned synthetic fibers which are opened and blended, randomly aligned into a web by airflow, joined by phenolic or latex binding agents and heat cured to produce a varying mesh, said mat being
15 of unitary sheet construction having no dissimilar sheets laminated or otherwise bonded together.

28. The improved material of claim 27, further comprising the mat having sufficient compression resistance to maintain its thickness as spacing between
20 the roof and capping materials.

29. The improved material of claim 27, further comprising said sheet being provided in a roll and adapted to be unrolled over the slot and cut to the desired mat length.

FIG. 1

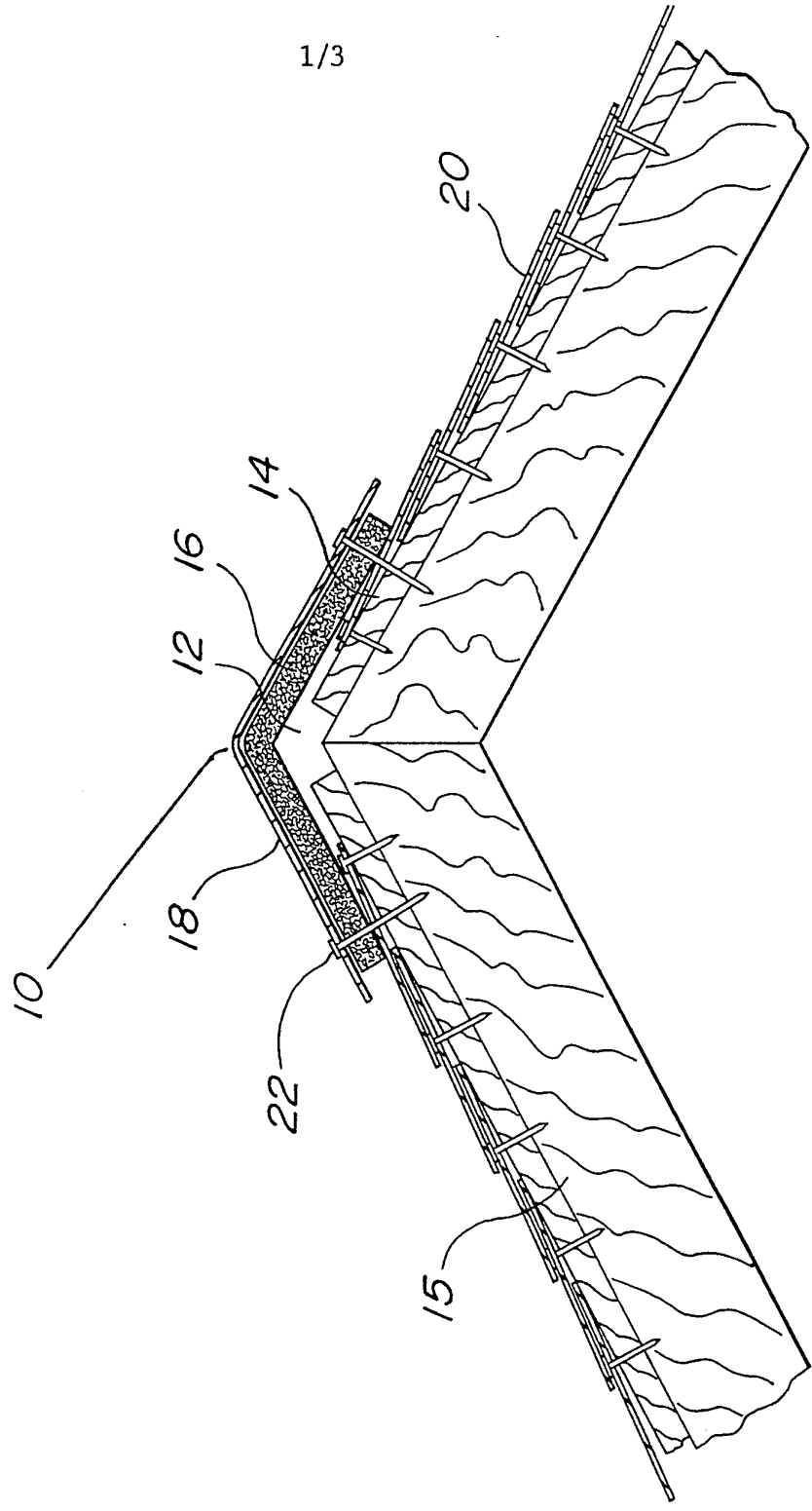

FIG. 2

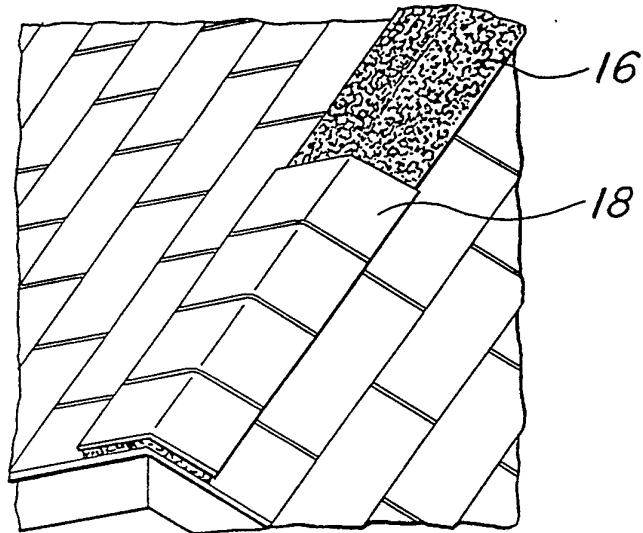

FIG. 3



FIG. 4

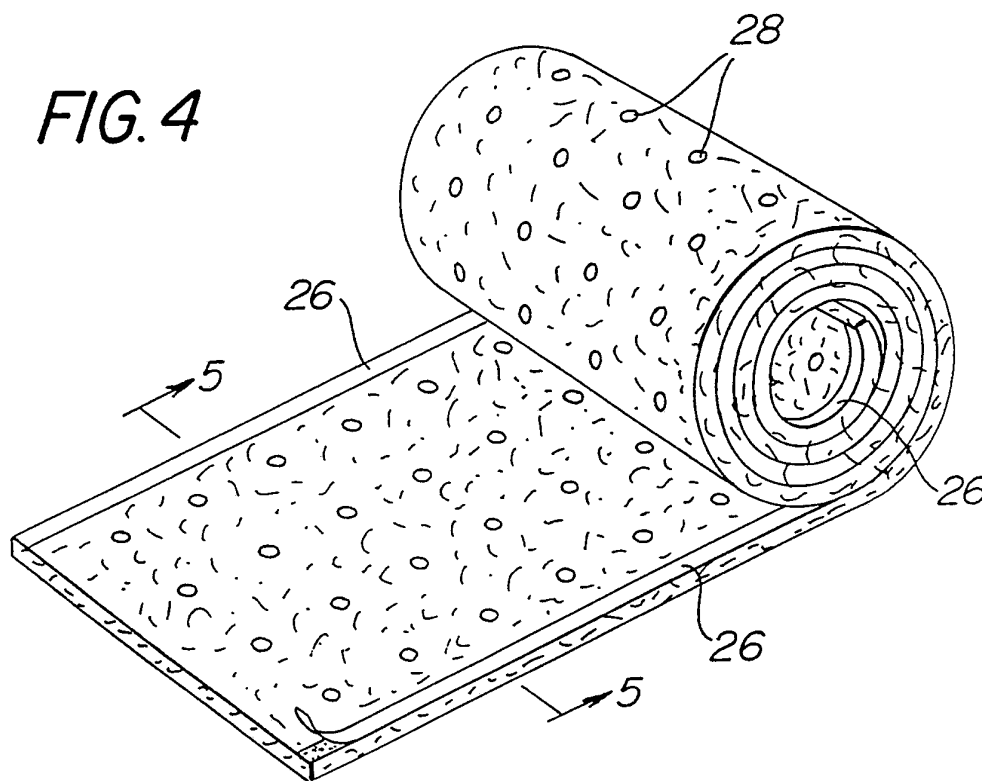
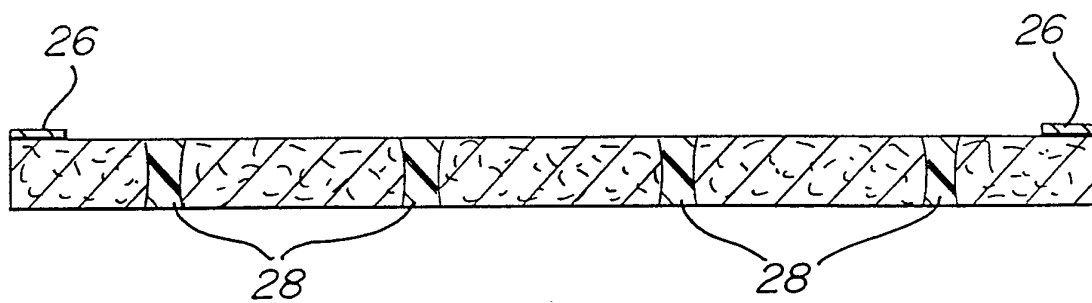

FIG. 5



INTERNATIONAL SEARCH REPORT

International application No.
PCT/US92/06658**A. CLASSIFICATION OF SUBJECT MATTER**

IPC(5) :F24F 7/02

US CL :454/365; 52/199

According to International Patent Classification (IPC) or to both national classification and IPC

B. FIELDS SEARCHED

Minimum documentation searched (classification system followed by classification symbols)

U.S. : 52/57, 199; 55/521, 524,527; 454/365

Documentation searched other than minimum documentation to the extent that such documents are included in the fields searched

Electronic data base consulted during the international search (name of data base and, where practicable, search terms used)

C. DOCUMENTS CONSIDERED TO BE RELEVANT

Category*	Citation of document, with indication, where appropriate, of the relevant passages	Relevant to claim No.
Y	US, A, 4,876,950 (RUDEEN) 31 October 1989, See column 3, lines 35-61.	22-29
Y	US, A, 4,942,699 (Spinelli) 24 July 1990. See column 4, lines 49-61.	22-29

 Further documents are listed in the continuation of Box C.
 See patent family annex.

* Special categories of cited documents:	"T" later document published after the international filing date or priority date and not in conflict with the application but cited to understand the principle or theory underlying the invention
"A" document defining the general state of the art which is not considered to be part of particular relevance	"X" document of particular relevance; the claimed invention cannot be considered novel or cannot be considered to involve an inventive step when the document is taken alone
"E" earlier document published on or after the international filing date	"Y" document of particular relevance; the claimed invention cannot be considered to involve an inventive step when the document is combined with one or more other such documents, such combination being obvious to a person skilled in the art
"L" document which may throw doubts on priority claim(s) or which is cited to establish the publication date of another citation or other special reason (as specified)	"&" document member of the same patent family
"O" document referring to an oral disclosure, use, exhibition or other means	
"P" document published prior to the international filing date but later than the priority date claimed	

Date of the actual completion of the international search

21 OCTOBER 1992

Date of mailing of the international search report

03 DEC 1992

Name and mailing address of the ISA/
Commissioner of Patents and Trademarks
Box PCT
Washington, D.C. 20231

Authorized officer

HAROLD JOYCE

Facsimile No. NOT APPLICABLE

Telephone No. (703) 308-0274