

W. M. Arthur,

Bed Bottom.

No. 111,364.

Patented Jan. 31, 1871.

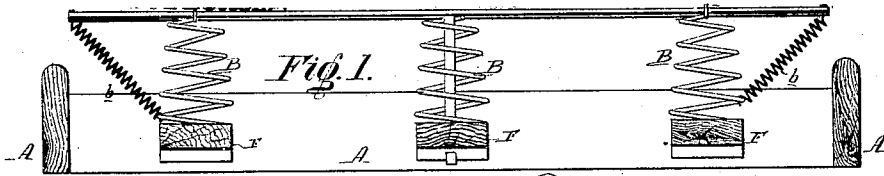

Fig. 2.

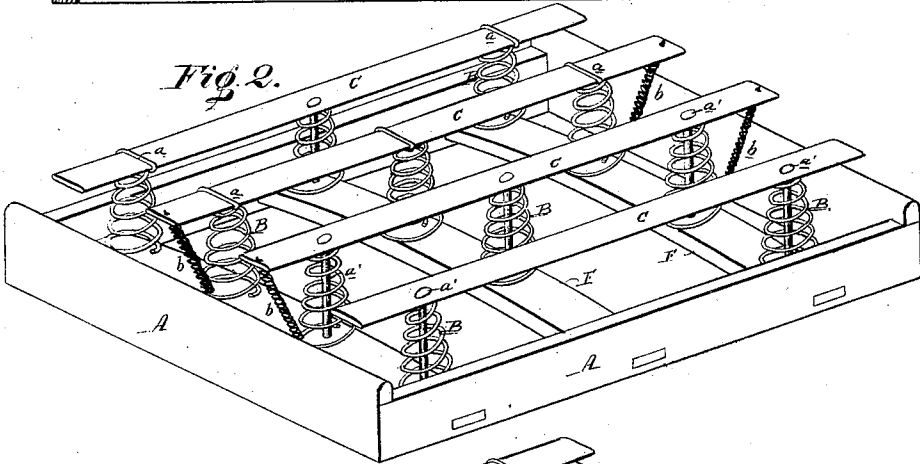

Fig. 3.

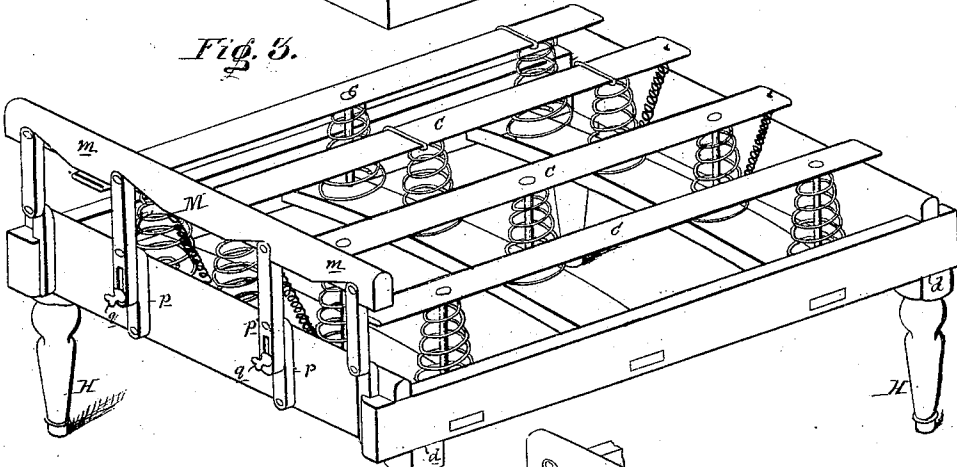

Fig. 4.

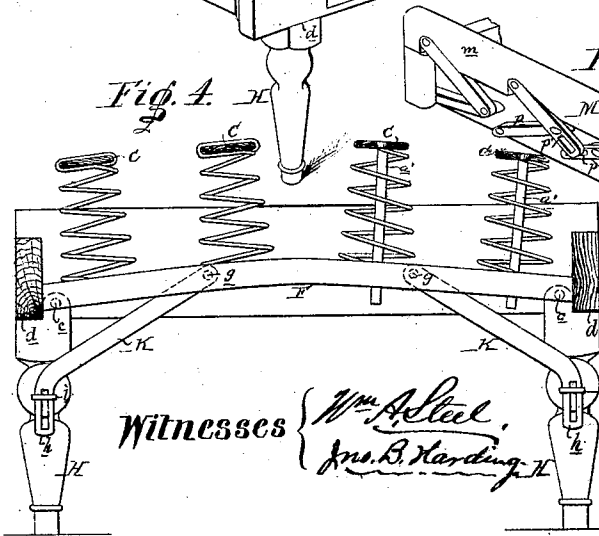
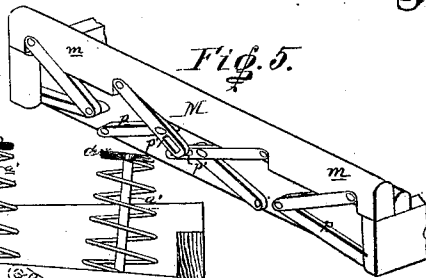

Fig. 5.



Witnesses

Wm. Steel,
Jno. B. Harding.

Inventor:
Wm. M. Arthur
by his Attor
Howson & Son

United States Patent Office.

WILLIAM McARTHUR, OF PHILADELPHIA, PENNSYLVANIA.

Letters Patent No. 111,364, dated January 31, 1871.

IMPROVEMENT IN BEDSTEADS AND SPRING BED-BOTTOMS.

The Schedule referred to in these Letters Patent and making part of the same.

I, WILLIAM McARTHUR, of Philadelphia, county of Philadelphia, State of Pennsylvania, have invented certain Improvements in Spring Bedsteads and Bed-Bottoms, of which the following is a specification.

Nature and Object of the Invention.

My invention consists—

First, in the combination, in a bedstead, of certain inclined "pull-springs" with the usual supporting-springs, for the purpose of relieving the strain upon the latter, and of preventing any longitudinal swaying of the slats.

Secondly, of certain sliding rods passing through each supporting-spring from the slat above, and arranged to slide through an opening in the cross-piece beneath, as hereafter described.

Thirdly, of a folding head-board, which can be raised when required for use, or lowered out of the way when it is no longer needed.

Description of the Accompanying Drawing.

Figure 1 is a longitudinal section of a spring bed-bottom constructed in accordance with my invention;

Figure 2, a perspective view of the same;

Figure 3, a perspective view of a complete bedstead with my improvement;

Figure 4, a transverse section of fig. 3; and

Figure 5, a perspective view of the folding head-board.

General Description.

On reference to figs. 1 and 2—

A represents the square or rectangular frame of a spring bed-bottom arranged to be supported upon the transverse rails of a bedstead in the usual manner.

The conical coiled springs B, for the support of the slats C, rest upon curved cross-pieces F, which extend across the frame A.

These springs may be coiled around the slats, as shown at *a*, so as to enable the slats to be longitudinally withdrawn from the same; but I prefer, as fastening devices for the springs, to use rods *a'*, secured to each *s'* it directly above the springs, and passing downward through the center of the latter, and through openings in the cross-pieces F.

These rods slide through the openings in the cross-pieces when the slats are lowered or raised, and the springs correspondingly compressed or extended, and, while preventing the lateral displacement of the said springs, enable the same and the slats

to be readily detached and removed from the frame by merely raising the said slats, and thus withdrawing the rods.

For the purpose of preventing any longitudinal play of the slats, and consequent strain upon the springs B and rods *a'*, I employ what I have termed "pull-springs," *b*, one of which is attached to each end of each slat, and to the adjacent spring B or cross-piece in an inclined position, as best observed in fig. 1.

The action of these springs will be readily understood without explanation.

Instead of adapting the frame A, with its slats and springs, to a bedstead, as above mentioned, it can itself be made to form a bedstead, as shown in the last three figures of the drawing, all that is necessary being to furnish it with four feet or legs H, and with a head-board, M.

The legs H are hinged to the frame A or cross-pieces, or to both, at the points *c*, and are arranged to be folded up into the frame, so as to occupy but little room when the bed is not in use.

When extended vertically downward, the said legs are prevented from turning outward by their shoulders *d*, which bear against the side rails of the frame, and they are prevented from turning inward by diagonal braces K, hinged to the cross-pieces or frame at the points *g*, and bent and slotted at their outer ends *h*, so that they may be readily secured to the legs by T-headed buttons *i* of the latter. (See fig. 4.)

The head-board M is also arranged to be folded downward upon the end rail of the frame, so that it may occupy but little room when not required for use.

It consists of a bar, *m*, (or head-board proper,) which is connected to the end rail by a series of double-hinged arms, *p* and *p'*, the arms *p'* being slotted, and provided with suitable holes, for the admission of thumb-screws or pins *q*, which are secured to the end rail when the head-board is elevated, as shown in fig. 3, and thus serve to hold the latter rigidly, and prevent the folding of the hinged arms.

When the head-board is no longer required, the set-screws or pins are withdrawn, and the whole is folded downward, as shown in fig. 5, the bar *m* resting upon the projecting ends of the side rails of the frame.

Claims.

1. The springs *b*, connected at their upper ends to the ends of the slats, and at their opposite ends at

the lower ends of the springs B, substantially as described.

2. The combination of the lower slats or supports F, upper slats C, intermediate coiled springs B, and pins *a*, when the latter extend through both slats and through the springs, and can be detached by drawing them through the upper slats, as set forth.

3. The folding head-board M, hung to the end rail of the frame, and constructed and arranged

to be operated substantially in the manner described.

In testimony whereof I have signed my name to this specification in the presence of two subscribing witnesses.

WILLIAM McARTHUR.

Witnesses:

C. HOWSON,
WM. A. STEEL.