



- (51) International Patent Classification:
E21B 41/00 (2006.01) E21B 43/116 (2006.01)
E21B 43/11 (2006.01)
- (21) International Application Number: PCT/US2016/037310
- (22) International Filing Date: 14 June 2016 (14.06.2016)
- (25) Filing Language: English
- (26) Publication Language: English
- (30) Priority Data: 62/182,972 22 June 2015 (22.06.2015) US
- (71) Applicant (for CA only): SCHLUMBERGER CANADA LIMITED [CA/CA]; 125 - 9 Avenue SE, Calgary, Alberta T2G 0P6 (CA).
- (71) Applicant (for FR only): SERVICES PETROLIERS SCHLUMBERGER [FR/FR]; 42 rue Saint Dominique, Paris 75005 (FR).
- (71) Applicant (for all designated States except CA, FR, US): SCHLUMBERGER TECHNOLOGY B.V. [NL/NL]; Parkstraat 83-89m, NL-2514 JG The Hague (NL).
- (72) Inventors: CAIRNEY, Thomas; 82 Napier Street, Cottesloe, WA 6011 (AU). GIBB, Derek; 26A Searle Road, Ardross, Perth, WA 6153 (AU). THISSEN, Michiel; 28 Rosendo Street, Cottesloe, WA 6011 (AU). HAMADEH, Farouk; 1/41 Mount Street, West Perth, WA 6005 (AU).

[Continued on next page]

(54) Title: Y-TOOL SYSTEM FOR USE IN PERFORATION AND PRODUCTION OPERATION

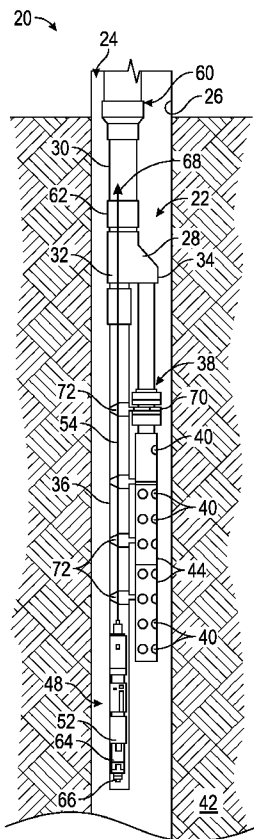

FIG. 2

(57) Abstract: A technique facilitates perforation and production of desired well fluids from a subterranean reservoir. A well system is deployed in a wellbore and comprises a Y-tool coupled with tubing. The Y-tool has a first branch and a second branch generally opposite the tubing. A bypass tube is coupled with the first branch and a perforating gun assembly extends below the second branch. The perforating gun assembly is disposed adjacent the bypass tube. Additionally, the perforating gun assembly has a plurality of perforating charges, e.g. shaped charges, oriented to create perforations into a surrounding formation without perforating the bypass tube.



(74) **Agents:** STONEBROOK, Michael et al.; 10001 Richmond Avenue, IP Administration Center of Excellence, Room 4720, Houston, Texas 77042 (US).

(81) **Designated States** (*unless otherwise indicated, for every kind of national protection available*): AE, AG, AL, AM, AO, AT, AU, AZ, BA, BB, BG, BH, BN, BR, BW, BY, BZ, CA, CH, CL, CN, CO, CR, CU, CZ, DE, DK, DM, DO, DZ, EC, EE, EG, ES, FI, GB, GD, GE, GH, GM, GT, HN, HR, HU, ID, IL, IN, IR, IS, JP, KE, KG, KN, KP, KR, KZ, LA, LC, LK, LR, LS, LU, LY, MA, MD, ME, MG, MK, MN, MW, MX, MY, MZ, NA, NG, NI, NO, NZ, OM, PA, PE, PG, PH, PL, PT, QA, RO, RS, RU, RW, SA, SC, SD, SE, SG, SK, SL, SM, ST, SV, SY, TH, TJ, TM, TN, TR, TT, TZ, UA, UG, US, UZ, VC, VN, ZA, ZM, ZW.

(84) **Designated States** (*unless otherwise indicated, for every kind of regional protection available*): ARIPO (BW, GH, GM, KE, LR, LS, MW, MZ, NA, RW, SD, SL, ST, SZ, TZ, UG, ZM, ZW), Eurasian (AM, AZ, BY, KG, KZ, RU, TJ, TM), European (AL, AT, BE, BG, CH, CY, CZ, DE, DK, EE, ES, FI, FR, GB, GR, HR, HU, IE, IS, IT, LT, LU, LV, MC, MK, MT, NL, NO, PL, PT, RO, RS, SE, SI, SK, SM, TR), OAPI (BF, BJ, CF, CG, CI, CM, GA, GN, GQ, GW, KM, ML, MR, NE, SN, TD, TG).

Published:

— with international search report (Art. 21(3))

PATENT APPLICATION

**Y-TOOL SYSTEM FOR USE IN PERFORATION AND PRODUCTION
OPERATION****CROSS-REFERENCE TO RELATED APPLICATION**

[0001] The present document is based on and claims priority to U.S. Provisional Application Serial No.: 62/182,972, filed June 22, 2015, which is incorporated herein by reference in its entirety.

BACKGROUND

[0002] Oil and gas wells utilize a borehole drilled into an earth formation and subsequently completed with equipment to facilitate production of the desired fluids from a reservoir. After drilling the borehole, the earth formation often is perforated to facilitate flow of desired well fluids, e.g. oil and gas, into the borehole. The well fluids may then be produced to the surface or to another desired location. However, perforation of the formation and subsequent production of the well fluids can involve multiple trips downhole into the borehole. The multiple trips tend to be relatively costly and time-consuming.

SUMMARY

[0003] In general, a system and methodology facilitate perforation and production of desired well fluids from a subterranean reservoir. A well system is deployed in a wellbore and comprises a Y-tool coupled with a tubing and having a first branch and a

second branch opposite the tubing. A bypass tube is coupled with the first branch and a perforating gun assembly extends below the second branch. The perforating gun assembly is disposed adjacent, e.g. laterally offset from, the bypass tube. Additionally, the perforating gun assembly has a plurality of perforating charges, e.g. shaped charges, oriented to create perforations into a surrounding formation without perforating the bypass tube.

[0004] However, many modifications are possible without materially departing from the teachings of this disclosure. Accordingly, such modifications are intended to be included within the scope of this disclosure as defined in the claims.

BRIEF DESCRIPTION OF THE DRAWINGS

[0005] Certain embodiments of the disclosure will hereafter be described with reference to the accompanying drawings, wherein like reference numerals denote like elements. It should be understood, however, that the accompanying figures illustrate the various implementations described herein and are not meant to limit the scope of various technologies described herein, and:

[0006] Figure 1 is a schematic illustration of an example of a well system deployed in a wellbore and comprising a Y-tool, according to an embodiment of the disclosure;

[0007] Figure 2 is an illustration of another example of a well system utilizing a Y-tool, according to an embodiment of the disclosure;

[0008] Figure 3 is an illustration of another example of a well system utilizing a Y-tool, according to an embodiment of the disclosure;

[0009] Figure 4 is a flow diagram illustrating an example of a methodology for utilizing the well system to facilitate production of well fluid, according to an embodiment of the disclosure; and

[0010] Figure 5 is a flow diagram illustrating another example of a methodology for utilizing the well system to facilitate production of well fluid, according to an embodiment of the disclosure.

DETAILED DESCRIPTION

[0011] In the following description, numerous details are set forth to provide an understanding of some embodiments of the present disclosure. However, it will be understood by those of ordinary skill in the art that the system and/or methodology may be practiced without these details and that numerous variations or modifications from the described embodiments may be possible.

[0012] The present disclosure generally relates to a system and methodology which facilitate formation perforation and production of desired well fluids from a subterranean reservoir. A well system is deployed in a wellbore and comprises a Y-tool coupled with and deployed downhole by a tubing. The Y-tool has a first branch and a second branch disposed generally opposite the tubing. A bypass tube is coupled with the first branch and a perforating gun assembly extends below the second branch. The perforating gun assembly is disposed adjacent the bypass tube, e.g. laterally offset from the bypass tube such that the bypass tube and the perforating gun assembly extend alongside each other.

[0013] Additionally, the perforating gun assembly has a plurality of perforating charges, e.g. shaped charges, oriented to create perforations into a surrounding formation. The perforating gun assembly is oriented and the perforating charges are arranged to create the perforations without perforating the bypass tube. In some embodiments, a

pump, e.g. a rod pump, is deployed in the bypass tube. This allows the pump and the perforating gun assembly to be deployed downhole in a single trip by using the Y-tool.

[0014] Referring generally to Figure 1, an embodiment of a well system 20 utilizing a bypass system 22 is illustrated as deployed in a borehole 24, e.g. a wellbore. By way of example, the wellbore 24 may be cased with a casing 26. In the illustrated example, the bypass system 22 of overall well system 20 comprises a Y-tool 28 which may be deployed downhole via a tubing 30, e.g. production tubing. For example, the tubing 30 may be coupled with the Y-tool 28 above the Y-tool 28. Additionally, the Y-tool 28 comprises a first branch 32 and a second branch 34 which may be positioned and oriented generally on an opposite side of Y-tool 28 relative to tubing 30. In the illustrated example, the first branch 32 is generally, linearly aligned with tubing 30.

[0015] In this embodiment, the well system 20 further comprises a bypass tube 36 connected to the first branch 32 of Y-tool 28. As illustrated, a perforating gun assembly 38 may be deployed from, e.g. beneath, the second branch 34 of Y-tool 28. The first branch 32 and the second branch 34 of Y-tool 28 are arranged such that the perforating gun assembly 38 is adjacent the bypass tube 36 and in some applications may be laterally offset from the bypass tube 36. The perforating gun assembly 38 comprises a plurality of perforating charges 40, e.g. shaped charges, oriented to form perforations through casing 26 and into a surrounding formation 42. The formation 42 may contain desirable fluids for production, such as oil, gas, and/or other hydrocarbon-based fluids. The perforating charges 40 are arranged and the perforating gun assembly 38 is oriented such that upon detonation of the perforating charges 40 the bypass tube 36 is not perforated.

[0016] Depending on the application, the perforating gun assembly 38 may comprise a single perforating gun 44 or a plurality of perforating guns 44. In some embodiments, the perforating gun assembly 38 is in the form of a tubing conveyed perforating (TCP) gun assembly which may be deployed down through Y-tool 28 and through first branch 32 via coiled tubing or other suitable conveyance. In the

embodiment illustrated, however, the perforating gun assembly 38 may be deployed downhole with Y-tool 28 while suspended from second branch 34.

[0017] In the embodiment illustrated, the well system 20 further comprises a pumping system 48 deployed into bypass tube 36 and mounted in place by a suitable fixture 50. In this example, tubing 30, first branch 32, and bypass tube 36 are generally aligned. In some applications, the pumping system 48 comprises a pump 52, e.g. a rod pump. In a specific application, pump 52 is a rod pump powered by a suitable rod 54 extending from pump 52 to a suitable power source at the surface. However, a variety of other types of pumps 52 may be deployed in bypass tube 36.

[0018] Depending on the parameters of a given well operation, the pumping system 48 may be deployed down through tubing 30 and bypass tube 36 after well system 20 is positioned in wellbore 24. However, the pumping system 48 also may be positioned in bypass tube 36 first and then deployed downhole with the overall system 20. In some applications, the rod pump 52 or other type of pumping system 48 may be deployed downhole with perforating gun assembly 38 in a single trip via Y-tool 28.

[0019] For some applications, a packer 56 may be installed along tubing 30 to isolate the portion of wellbore 24 below packer 56 during, for example, a perforation procedure. Additionally, a valve 58, e.g. an annular vent valve (AAV), or other similar tool may be installed on the packer 56. In some applications, the valve 58 may be combined with a hydraulic control line to the surface and may be selectively held in an open valve position via pressure applied to the hydraulic control line. This allows venting of produced gases from the formation 42, which gases may then flow to surface facilities. The valve 58 can be closed when desired by, for example, reducing pressure in the hydraulic control line. It should be noted that other types of valves 58 may be combined with packer 56. Similarly, packer 56 may have a variety of configurations and may be set according to suitable techniques. For example, the packer 56 may be set by using hydraulic pressure applied against a plug temporarily positioned in a nipple above the Y-tool 28. This latter configuration also enables pressure testing along tubing 30.

[0020] Referring generally to Figure 2, another embodiment of a well system 20 is illustrated. In this embodiment, bypass system 22 is deployed into wellbore 24 with well system 20. The bypass system 22 may comprise a variety of components, such as a handling sub 60, a top nipple 62, and Y-tool 28. By way of example, the Y-tool 28 may be in the form of the Y-Tool Sub Assembly available from Schlumberger Technology Corporation of Houston Texas.

[0021] As illustrated in Figure 2, the Y-tool 28 may be coupled with tubing 30 via top nipple 62 so that it is in fluid communication with bypass tubing 36 (as with the embodiment illustrated in Figure 1). The lower portion of bypass tubing 36 may be in the form of a tail pipe 64 and may be combined with a check valve 66 which allows well fluid to flow into the bypass tubing 36. For example, the check valve 66 may be used to prevent down flow of fluid while allowing well fluid to flow into bypass tubing 36 from wellbore 24 for pumping via pumping system 48.

[0022] In this embodiment, pump 52 is in the form of a rod pump disposed in tail pipe 64 and may be operated via rod 54 to pump well fluid to the surface in the direction of arrow 68. In some applications, the pump 52 may be conveyed downhole through tubing 30 and inserted into bypass tubing 36 after deployment of the bypass system 22 but before perforation, e.g. before detonation of perforation charges 40. The second branch 34 of Y-tool 28 may be connected to perforating gun assembly 38 and/or permit the routing of perforating gun assembly 38 to a position adjacent the bypass tube 36, e.g. a positioned laterally offset from bypass tube 36.

[0023] Perforating gun assembly 38 may again comprise one or more perforating guns 44 which may be selectively detonated via a firing head 70. Additionally, a clamp 72 (or a plurality of clamps 72) may be used to secure the perforating gun assembly 38 to the bypass tubing 36. In some applications, the pumping system 48 and the perforating gun assembly 38 may be placed at their respective positions beneath Y-tool 28; and then the well system 20 may be deployed downhole with the pumping system 48 and

perforating gun assembly 38 in a single trip. In such an application, the clamps 72 may be used to secure the perforating gun assembly 38 to the bypass tube 36 prior to being deployed to the desired downhole location. However, the Y-tool 28 enables later change out and/or deployment of the pumping system 48 in some operational embodiments.

[0024] In some applications, the perforating gun assembly 38 may be in the form of a tubing conveyed perforating gun utilizing firing head 72 selectively to detonate perforation charges 40. In the embodiment illustrated in Figure 2 (as with the embodiment illustrated in Figure 1), the perforation charges 40 may be oriented so that upon detonation they fire in a desired pattern which avoids perforating bypass tubing 36. For example, the perforation charges 40 may be in the form of shaped charges arranged to fire into formation 42 in an arc which avoids bypass tubing 36 when perforating gun assembly 38 is properly oriented. Following perforation, well fluids may flow into wellbore 24 and into bypass tube 36 through the lower end of the bypass tube 36, e.g. through check valve 66, for pumping via pumping system 48. The pumping system 48 can be deployed with bypass tube 36. Or, the pumping system 48 and/or other service tools may be deployed downhole in a separate run in hole without having to control the resulting influx of well fluid.

[0025] Some formations 42 can be difficult or cost prohibitive to control once the formation 42 is opened to the wellbore 24 via detonation of perforation charges 40. In these types of applications, it may not be possible or desirable to access the wellbore 24 to install artificial lift systems or other completion products or tools. Embodiments of bypass assembly 22 enable both the artificial lift/pumping system 48 and the tubing conveyed perforating gun assembly 38 to be run in a single intervention, provided there is adequate surface well control. This technique facilitates safe access to the producing formation 42 as well as economic production of hydrocarbons.

[0026] In some applications, the well system 20 is initially deployed downhole in wellbore 24 with bypass tubing 36. The perforating gun assembly 38 is deployed downhole simultaneously or subsequent to placement of bypass system 22 at a desired

location in wellbore 24. A test plug is then delivered downhole toward Y-tool 28 to enable, for example, pressure testing of production tubing 30. The test plug may then be readily removed to enable installation of other tools down through Y-tool 28.

[0027] For example, pumping system 48 may be deployed in bypass tube 36 or other tools may be deployed downhole through bypass tube 36. In one embodiment, pump 52 is a rod pump which is inserted down into bypass tube 36 via a rod string. The rod string may be inserted through a stuffing box located on the surface. This allows the well to be pressured up against the check valve 66 at the bottom of the bypass tube 36 and against the firing head 70. The applied pressure and/or other techniques may be used to energize the perforating guns 44, detonate perforating charges 40, and perforate the surrounding formation 42. The hydrocarbon production fluids can then either be free-flowed for a period of time if possible, or the rod pump 52 may be hooked up to the topside facilities and operated to lift fluids to the surface along production tubing 30. Other types of pumping systems 48 also may be operated to lift fluids to the surface.

[0028] The Y-tool 28 also enables deployment of other types of tools and systems to desired positions downhole. For example, the bypass tube 36 may be used to pass various tools to wellbore locations beneath well system 20. Additionally, the perforating gun assembly 38 may be operated to form the desired perforations and then removed, e.g. released. In some applications, the perforating gun assembly 38 may be replaced or substituted with other systems.

[0029] As illustrated in Figure 3, for example, the perforating gun assembly 38 has been replaced by an electric submersible pumping system 74 and bypass tube 36 remains open for the passage of tools, e.g. a tubing conveyed perforating gun assembly, treatment fluids, or other items. In this embodiment, the electric submersible pumping system 74 is coupled to Y-tool 28 at the second branch 34 via a pump sub 76. By way of example, the electric submersible pumping system 74 comprises a submersible motor 78, a motor protector 80, and a submersible pump 82 powered by the submersible motor 78. The pumping system 74 also may comprise other components, such as a motor base plug

84, a gauge system 86, a discharge pressure sub 88, a discharge head 90, and/or other components appropriate for a given operation.

[0030] The overall system 20 may comprise other components to accommodate parameters of a given application. For example, the bypass tube 36 may be coupled with Y-tool 28 via a tele-swivel 92. A wireline re-entry guide 94 may be disposed at the lower end of bypass tube 36 to facilitate reentry of, for example, wireline deployed components which are routed downhole through the bypass tube 36. In some applications, clamps 72 or other mounting components may be utilized to secure the electric submersible pumping system 74 in a position adjacent bypass tube 36. This type of embodiment enables the bypass tube 36 to be used as a conduit through which tools and services can be deployed and activated. For example, the bypass tube 36 may be used to provide a conduit past the electric submersible pumping system 74 to enable wireline and/or coiled tubing intervention work to be carried out downhole of electric submersible pumping system 74.

[0031] Referring generally to Figure 4, a flow diagram is provided to illustrate an example of a methodology utilizing system 20. In this example, the Y-tool 28 is initially deployed downhole in wellbore 24 with the bypass system 22, as represented by block 96. The perforating gun assembly 38 may be deployed downhole with Y-tool 28 or deployed through the second branch 34 of Y-tool 28 to enable perforation of wellbore 24, as represented by block 98. Once the formation 42 is perforated, well fluids flow into wellbore 24 and are produced from wellbore 24 up through bypass tube 36, as represented by block 100.

[0032] A slightly different embodiment of the methodology is illustrated by the flow diagram of Figure 5. In this embodiment, the Y-tool 28 is initially assembled with bypass tube 36 and perforating gun assembly 38, as represented by block 102. The Y-tool assembly is then located at a desired position in wellbore 24, as represented by block 104. Pumping system 48 is then lowered into position within bypass tube 36, as

represented by block 106. However, the pumping system 48 may be deployed with bypass tube 36 when the bypass system 22 is deployed downhole.

[0033] Once the Y-tool 28 and perforating gun assembly 38 are in position in wellbore 24 (before or after deployment of pumping system 48) the shaped charges 40 of the perforating gun assembly 38 are detonated in a direction which avoids perforating the bypass tube 36, as represented by block 108. The pumping system 48 may then be operated to produce well fluids, as represented by block 110. The well fluids may be produced up through bypass tube 36, Y-tool 28, and tubing 30 to a desired collection location, such as a surface collection location.

[0034] However, the methodology described herein as well as the system configuration can be adjusted according to the parameters of a given application and/or environment. For example, the well system 20 may comprise a variety of other and/or additional components. The pumping system 48 may comprise a rod pump or other suitable pumps deployed down into bypass tube 36. Or, the pumping system may be in the form of electric submersible pumping system 74 deployed on second branch 34. Similarly, many types of perforating gun assemblies with different numbers of perforating guns and perforating charges may be employed to perforate the surrounding formation 42 without damaging the perforating tube 36. The Y-tool 28 also may be configured to accommodate many types of tools and systems. For example, the Y-tool 28 may be used to deploy various tools through bypass tube 36 and/or to accommodate placement of other tools and systems via the second branch 34 in combination with perforating gun assembly 38 or as a substitute for the perforating gun assembly.

[0035] Although a few embodiments of the disclosure have been described in detail above, those of ordinary skill in the art will readily appreciate that many modifications are possible without materially departing from the teachings of this disclosure. Accordingly, such modifications are intended to be included within the scope of this disclosure as defined in the claims.

CLAIMS

What is claimed is:

- 1 1. A system, comprising:
2
3 a well system deployed in a wellbore, the well system comprising:
4 a Y-tool having a first branch and a second branch;
5 a bypass tube connected to the first branch of the Y-tool; and
6 a perforating gun assembly deployed from the second branch of the
7 Y-tool adjacent to the bypass tube, the perforating gun assembly
8 comprising one or more perforating charges disposed on the perforating
9 gun assembly such that upon detonation of the perforating charges the
10 bypass tube is not perforated.

- 1 2. The system as recited in claim 1, wherein the perforating gun assembly comprises
2 a pressure activated firing head.

- 1 3. The system as recited in claim 1, wherein the well system further comprises a
2 pump disposed in the bypass tube.

- 1 4. The system as recited in claim 3, wherein the pump is a rod pump.

- 1 5. The system as recited in claim 1, wherein the well system further comprises a
2 check valve disposed at an end of the bypass tube.

- 1 6. The system as recited in claim 1, wherein the perforating gun assembly is
2 conveyed downhole into the wellbore while coupled to the second branch.
1

- 1 7. The system as recited in claim 1, wherein the one or more perforating charges
2 comprises a plurality of shaped charges.

1 8. The system as recited in claim 1, wherein a pumping system is deployed into the
2 bypass tube prior to detonation.

1

1 9. The system as recited in claim 1, wherein the perforating gun assembly comprises
2 a plurality of perforating guns.

1

1 10. A method of perforating a wellbore, comprising:

2

3 conveying into a wellbore a bypass assembly having a Y-tool, a bypass
4 tube connected to the Y-tool, and a perforating gun assembly deployed from the
5 Y-tool adjacent to the bypass tube;

6 orienting the perforating gun assembly such that perforating charges
7 disposed on the perforating gun assembly do not perforate the bypass tube upon
8 detonation of the perforating charges; and

9 perforating a formation surrounding the wellbore by detonating the
10 perforating charges.

1 11. The method as recited in claim 10, further comprising deploying a pump in the
2 bypass tube.

1 12. The method as recited in claim 11, wherein deploying the pump comprises
2 deploying a rod pump.

1 13. The method as recited in claim 10, wherein perforating comprises using a
2 pressure activated firing head to detonate the perforating charges.

1 14. The method as recited in claim 11, further comprising positioning a check valve
2 in the bypass tube.

1

1 15. The method as recited in claim 10, further comprising securing the perforating
2 gun assembly to the bypass tube via a plurality of clamps.

1 16. The method as recited in claim 15, further comprising removing the perforating
2 gun assembly after detonation.

1 17. The method as recited in claim 11, wherein deploying comprises deploying the
2 pump into the bypass tube prior to detonation.

1 18. A system, comprising:

2

3 a Y-tool deployed in a wellbore via tubing;

4 a bypass tube coupled with a first branch of the Y-tool generally in line
5 with the tubing; and

6 a perforating gun assembly extending below a second branch of the Y-tool
7 at a position laterally offset from the bypass tube, the perforating gun assembly
8 having a plurality of shaped charges oriented to create perforations into a
9 surrounding formation without perforating the bypass tube.

1 19. The system as recited in claim 18, further comprising a pump positioned in the
2 bypass tube.

1 20. The system as recited in claim 18, wherein the perforating gun assembly is
2 secured to the second branch and to the bypass tube.

1/4

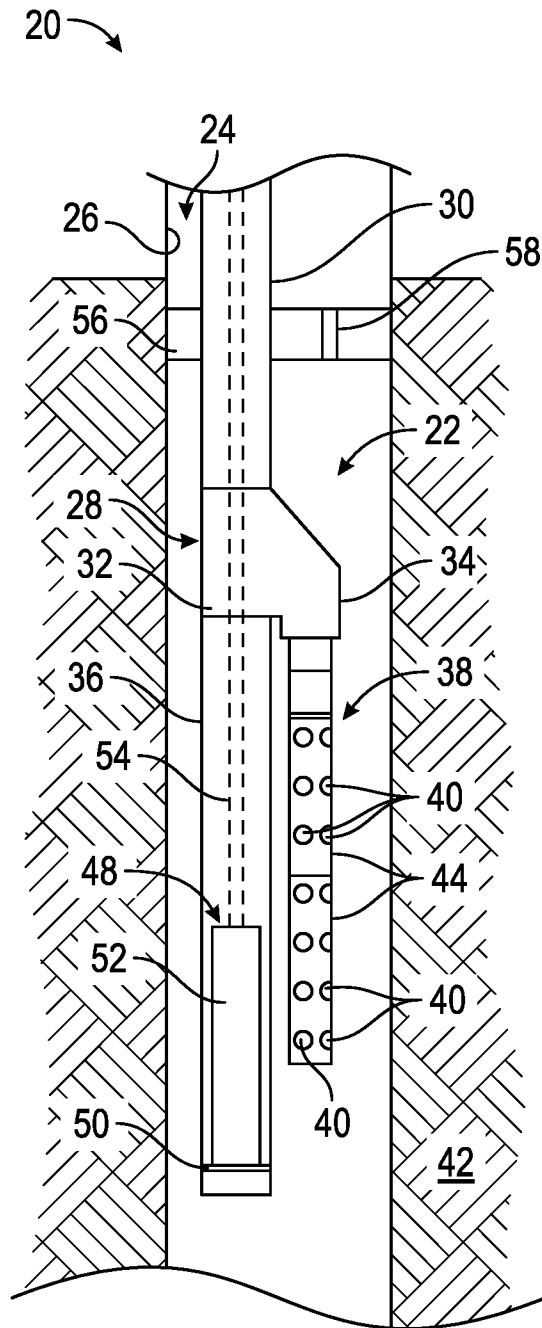

FIG. 1

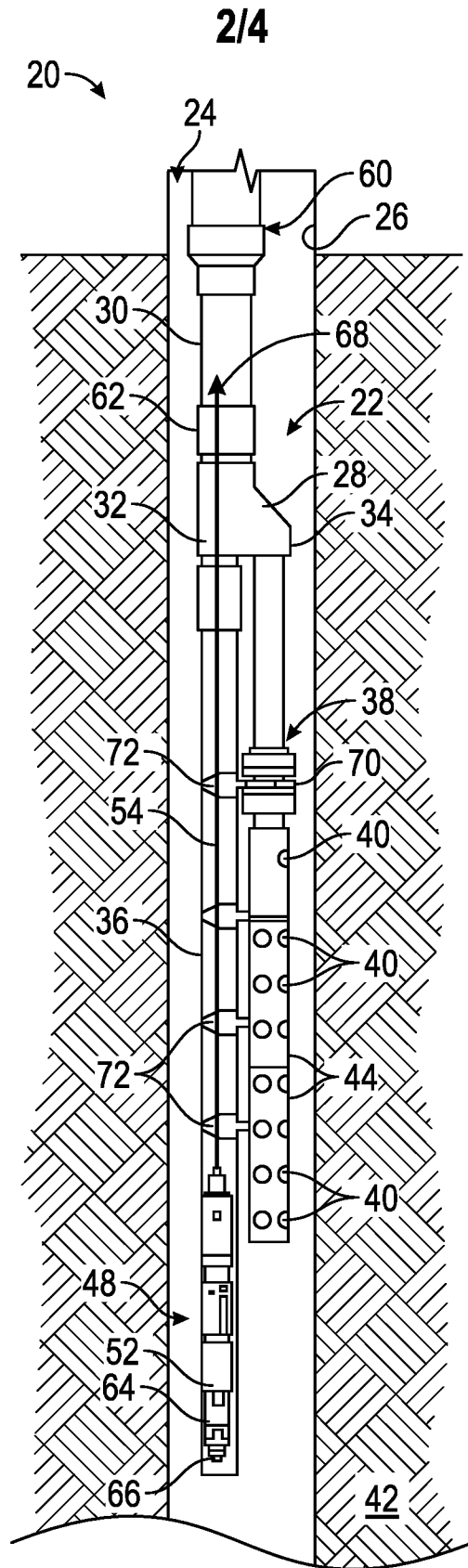

FIG. 2

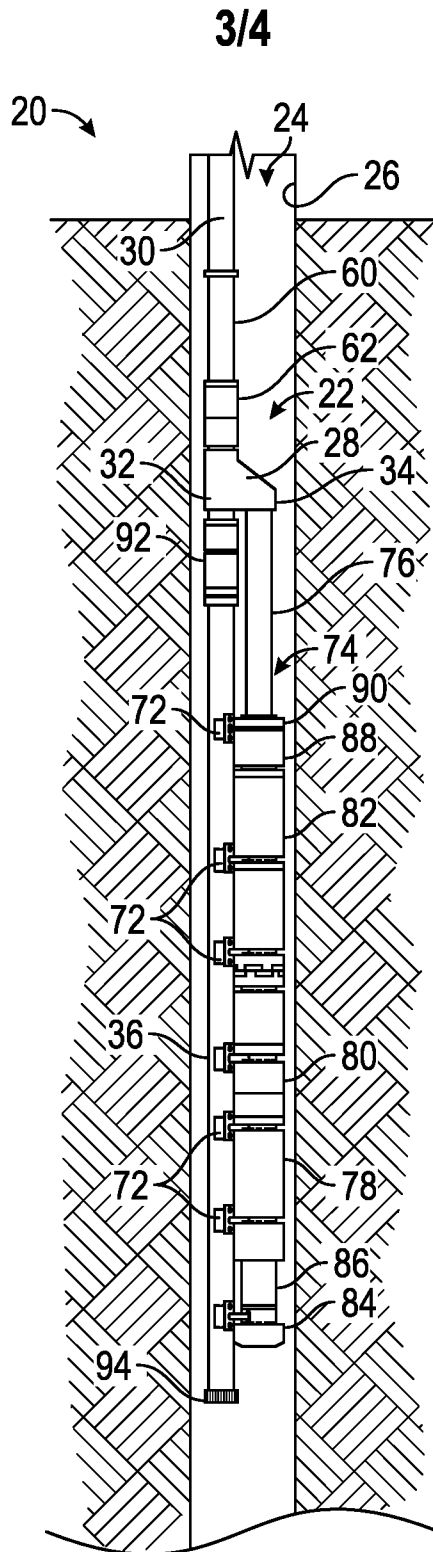

FIG. 3

4/4

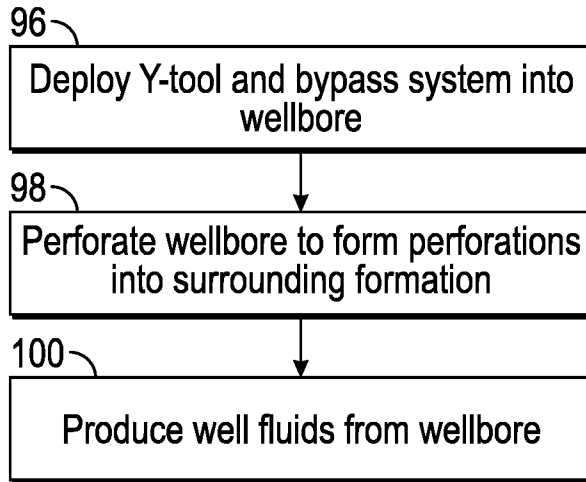

FIG. 4

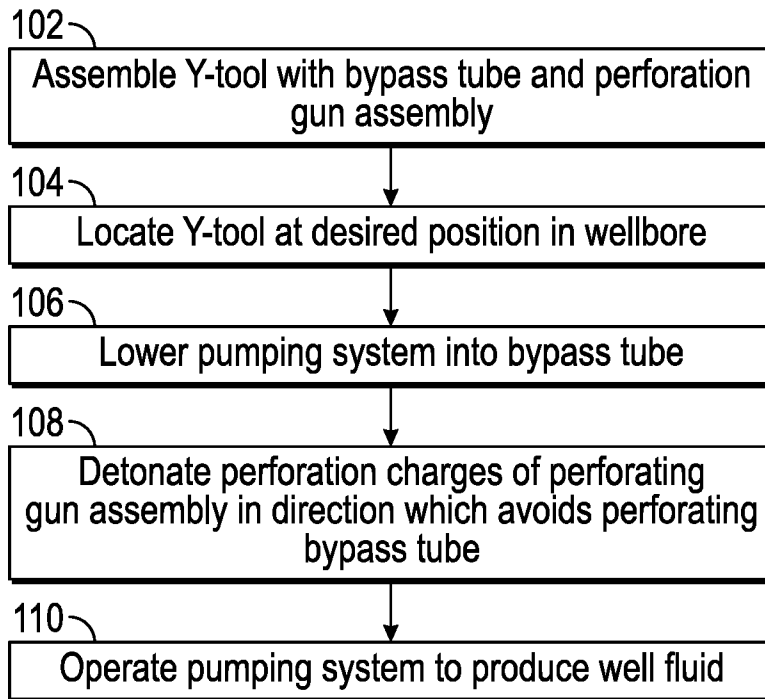

FIG. 5

A. CLASSIFICATION OF SUBJECT MATTER**E21B 41/00(2006.01)I, E21B 43/11(2006.01)I, E21B 43/116(2006.01)I**

According to International Patent Classification (IPC) or to both national classification and IPC

B. FIELDS SEARCHED

Minimum documentation searched (classification system followed by classification symbols)

E21B 41/00; E21B 47/00; E21B 43/04; E21B 43/00; E21B 37/00; E21B 4/04; E21B 19/00; E21B 43/117; E21B 43/11; E21B 43/116

Documentation searched other than minimum documentation to the extent that such documents are included in the fields searched

Korean utility models and applications for utility models

Japanese utility models and applications for utility models

Electronic data base consulted during the international search (name of data base and, where practicable, search terms used)

eKOMPASS(KIPO internal) & keywords: Y-tool, branch, charge, perforating gun, bypass, pressure, pump, rod and valve

C. DOCUMENTS CONSIDERED TO BE RELEVANT

Category*	Citation of document, with indication, where appropriate, of the relevant passages	Relevant to claim No.
X	US 2011-0048122 A1 (LE FOLL et al.) 03 March 2011 See abstract, paragraphs [0034]-[0045], claims 1-6 and figures 2-5b.	1, 2, 5-7, 9, 10, 13, 15 , 16, 18, 20
Y		3, 4, 8, 11, 12, 14, 17 , 19
Y	US 6322331 B1 (SWATEK et al.) 27 November 2001 See abstract, column 3, line 6 - column 4, line 28, claim 1 and figures 1-4.	3, 4, 8, 11, 12, 14, 17 , 19
A	US 2006-0231256 A1 (RIVAS et al.) 19 October 2006 See abstract, paragraphs [0010]-[0015], claims 19-31 and figures 1-6.	1-20
A	US 2004-0159434 A1 (JOHNSON et al.) 19 August 2004 See abstract, claims 1-9 and figures 3A-8.	1-20
A	US 2004-0129419 A1 (VAN WULFFTEN PALTHE, PAUL J.G.) 08 July 2004 See abstract, claims 7-18 and figures 1-2C.	1-20

 Further documents are listed in the continuation of Box C. See patent family annex.

* Special categories of cited documents:

"A" document defining the general state of the art which is not considered to be of particular relevance

"E" earlier application or patent but published on or after the international filing date

"L" document which may throw doubts on priority claim(s) or which is cited to establish the publication date of another citation or other special reason (as specified)

"O" document referring to an oral disclosure, use, exhibition or other means

"P" document published prior to the international filing date but later than the priority date claimed

"T" later document published after the international filing date or priority date and not in conflict with the application but cited to understand the principle or theory underlying the invention

"X" document of particular relevance; the claimed invention cannot be considered novel or cannot be considered to involve an inventive step when the document is taken alone

"Y" document of particular relevance; the claimed invention cannot be considered to involve an inventive step when the document is combined with one or more other such documents, such combination being obvious to a person skilled in the art

"&" document member of the same patent family

Date of the actual completion of the international search

09 September 2016 (09.09.2016)

Date of mailing of the international search report

19 September 2016 (19.09.2016)

Name and mailing address of the ISA/KR

International Application Division

Korean Intellectual Property Office

189 Cheongsa-ro, Seo-gu, Daejeon, 35208, Republic of Korea

Facsimile No. +82-42-481-8578

Authorized officer

LEE, Dal Kyong

Telephone No. +82-42-481-8440



INTERNATIONAL SEARCH REPORT

Information on patent family members

International application No.

PCT/US2016/037310

Patent document cited in search report	Publication date	Patent family member(s)	Publication date		
US 2011-0048122 A1	03/03/2011	AU 2008-329140 A1	04/06/2009		
		AU 2008-329140 B2	12/11/2015		
		CA 2707088 A1	04/06/2009		
		CN 101878350 A	03/11/2010		
		CN 101878350 B	11/03/2015		
		GB 201007648 D0	23/06/2010		
		GB 2467673 A	11/08/2010		
		MX 2010005562 A	02/06/2010		
		NO 20100695 A	15/06/2010		
		US 8776591 B2	15/07/2014		
		WO 2009-068302 A2	04/06/2009		
		WO 2009-068302 A3	24/09/2009		
		US 6322331 B1	27/11/2001	CA 2289286 A1	10/05/2000
				CA 2289286 C	14/08/2007
GB 2343693 A	17/05/2000				
GB 2343693 B	24/01/2001				
GB 9926644 D0	12/01/2000				
US 2006-0231256 A1	19/10/2006	US 7231978 B2	19/06/2007		
US 2004-0159434 A1	19/08/2004	AU 2001-47284 A1	12/09/2001		
		CA 2401184 A1	07/09/2001		
		CA 2401184 C	22/05/2007		
		CA 2481639 A1	19/03/2005		
		CA 2481639 C	19/05/2009		
		CA 2486091 A1	04/05/2005		
		CA 2486091 C	29/04/2008		
		CA 2502598 A1	30/09/2005		
		CA 2502598 C	10/12/2013		
		CA 2512480 A1	21/01/2006		
		CA 2512480 C	10/11/2009		
		CA 2654524 A1	19/03/2005		
		CA 2671282 A1	21/01/2006		
		CA 2671282 C	15/11/2011		
		CA 2671374 A1	21/01/2006		
		CA 2671374 C	01/11/2011		
		CA 2671521 A1	21/01/2006		
		CA 2671526 A1	21/01/2006		
		CA 2671526 C	20/05/2014		
		CN 1690357 A	02/11/2005		
		CN 1690357 B	04/07/2012		
		GB 0328361 D0	14/01/2004		
		GB 2377465 A	15/01/2003		
		GB 2396175 A	16/06/2004		
		GB 2396175 B	14/12/2005		
		GB 2403968 A	19/01/2005		
GB 2406114 A	23/03/2005				
GB 2408057 A	18/05/2005				

INTERNATIONAL SEARCH REPORT

Information on patent family members

International application No.

PCT/US2016/037310

Patent document cited in search report	Publication date	Patent family member(s)	Publication date
		GB 2416358 A	25/01/2006
		GB 2421966 A	12/07/2006
		GB 2432381 A	23/05/2007
		GB 2432382 A	23/05/2007
		MX PA03011421 A	19/04/2005
		NO 20035491 A	14/06/2004
		NO 20035491 D0	10/12/2003
		NO 336269 B1	06/07/2015
		RU 2003136025 A	20/05/2005
		RU 2352769 C2	20/04/2009
		SG 119206 A1	28/02/2006
		US 2002-0020535 A1	21/02/2002
		US 2003-0089498 A1	15/05/2003
		US 2003-0150646 A1	14/08/2003
		US 2004-0089449 A1	13/05/2004
		US 2004-0099418 A1	27/05/2004
		US 2004-0159432 A1	19/08/2004
		US 2004-0231840 A1	25/11/2004
		US 2005-0061506 A1	24/03/2005
		US 2005-0167108 A1	04/08/2005
		US 2007-0034369 A1	15/02/2007
		US 2007-0079960 A1	12/04/2007
		US 2009-0032258 A1	05/02/2009
		US 2010-0044044 A1	25/02/2010
		US 2011-0042089 A1	24/02/2011
		US 6554081 B1	29/04/2003
		US 6598682 B2	29/07/2003
		US 6732798 B2	11/05/2004
		US 6874579 B2	05/04/2005
		US 6896059 B2	24/05/2005
		US 6966377 B2	22/11/2005
		US 7036594 B2	02/05/2006
		US 7182138 B2	27/02/2007
		US 7284612 B2	23/10/2007
		US 7287589 B2	30/10/2007
		US 7428921 B2	30/09/2008
		US 7451819 B2	18/11/2008
		US 7845410 B2	07/12/2010
		US 7984761 B2	26/07/2011
		US 8347963 B2	08/01/2013
		WO 01-65060 A1	07/09/2001
US 2004-0129419 A1	08/07/2004	US 7665535 B2	23/02/2010