



US007582505B2

(12) **United States Patent**
Maeda et al.

(10) **Patent No.:** **US 7,582,505 B2**
(45) **Date of Patent:** **Sep. 1, 2009**

(54) **SOLID-STATE IMAGING DEVICE AND METHOD OF MANUFACTURING SAID SOLID-STATE IMAGING DEVICE**

(52) **U.S. Cl.** 438/75; 438/64; 438/68; 438/73

(58) **Field of Classification Search** None
See application file for complete search history.

(75) Inventors: **Hiroshi Maeda**, Kanagawa (JP);
Kazuhiro Nishida, Kanagawa (JP);
Yoshihisa Negishi, Kanagawa (JP);
Shunichi Hosaka, Kanagawa (JP)

(56) **References Cited**

U.S. PATENT DOCUMENTS

4,357,557	A	11/1982	Inohara et al.
5,436,492	A	7/1995	Yamanaka
5,641,713	A	6/1997	Kyle
6,342,406	B1	1/2002	Glenn et al.
6,407,381	B1	6/2002	Glenn et al.
2002/0019069	A1	2/2002	Wada

FOREIGN PATENT DOCUMENTS

EP	1 376 705	A2	1/2004
JP	6302997	A	2/1988
JP	63029974	*	2/1988

(Continued)

Primary Examiner—Zandra Smith

Assistant Examiner—Pamela E Perkins

(74) *Attorney, Agent, or Firm*—Birch, Stewart, Kolasch & Birch, LLP

(73) Assignee: **Fujifilm Corporation**, Tokyo (JP)

(*) Notice: Subject to any disclaimer, the term of this patent is extended or adjusted under 35 U.S.C. 154(b) by 302 days.

(21) Appl. No.: **11/404,902**

(22) Filed: **Apr. 17, 2006**

(65) **Prior Publication Data**

US 2006/0252175 A1 Nov. 9, 2006

Related U.S. Application Data

(60) Division of application No. 10/617,707, filed on Jul. 14, 2003, now Pat. No. 7,074,638, which is a continuation-in-part of application No. 10/419,861, filed on Apr. 22, 2003, now abandoned.

(30) **Foreign Application Priority Data**

Apr. 22, 2002	(JP)	P. 2002-119262
May 28, 2002	(JP)	P. 2002-154528
Jun. 24, 2002	(JP)	P. 2002-183072
Jul. 29, 2002	(JP)	P. 2002-219645
Jul. 29, 2002	(JP)	P. 2002-219791

(57) **ABSTRACT**

It is an object to provide solid-state imaging device, which can easily be manufactured and has a high reliability, and a method of manufacturing the solid-state imaging device. In the present invention, a manufacturing method comprises the steps of forming a plurality of IT-CCDs on a surface of a semiconductor substrate, bonding a translucent member to the surface of the semiconductor substrate in order to have a gap opposite to each light receiving region of the IT-CCD, and isolating a bonded member obtained at the bonding step for each of the IT-CCDs.

(51) **Int. Cl.**
H01L 21/00 (2006.01)

11 Claims, 70 Drawing Sheets

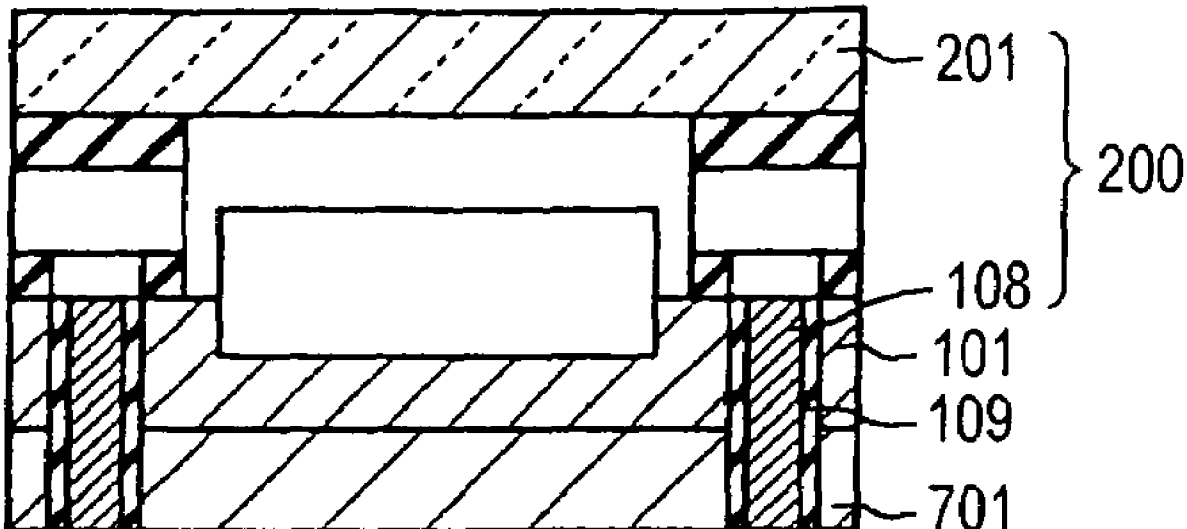

US 7,582,505 B2

Page 2

FOREIGN PATENT DOCUMENTS			WO	WO-01/43202 A	6/2001
JP	05110960 A	4/1993	WO	WO-03/019653 A	3/2003
JP	7-202152	8/1995			
JP	2002-329850	* 11/2002			

* cited by examiner

FIG. 1A

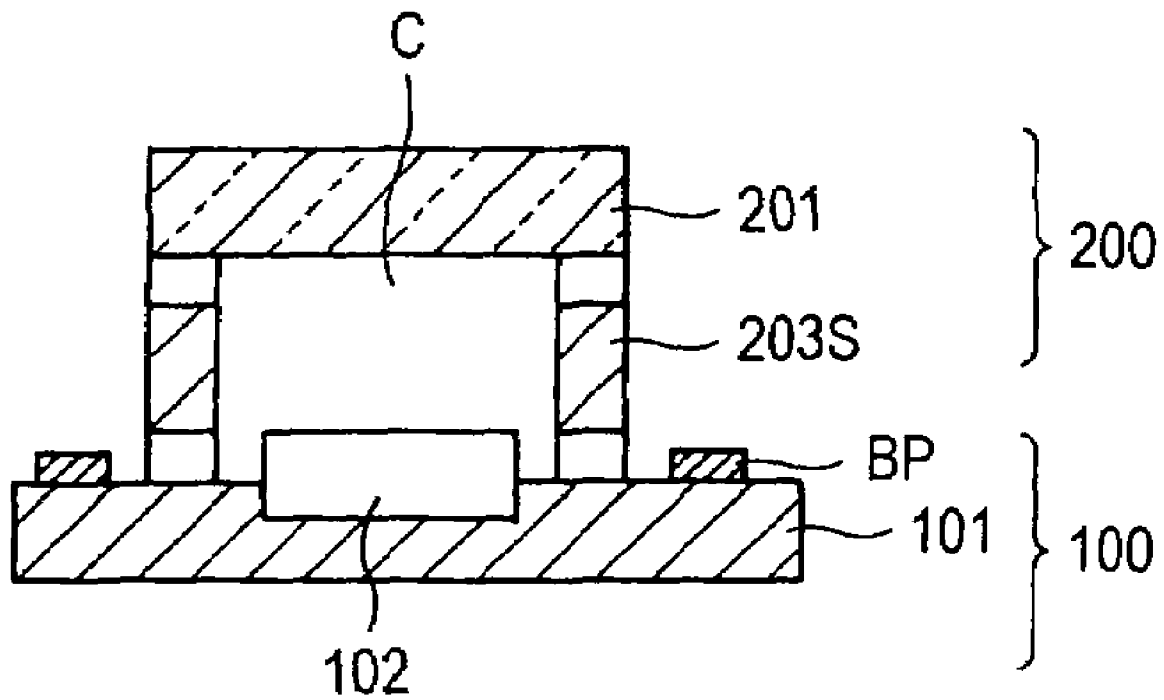

FIG. 2A

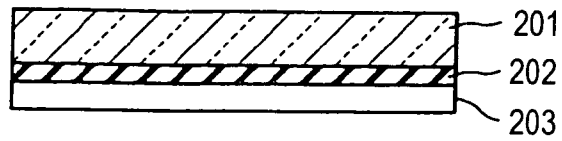

FIG. 2B

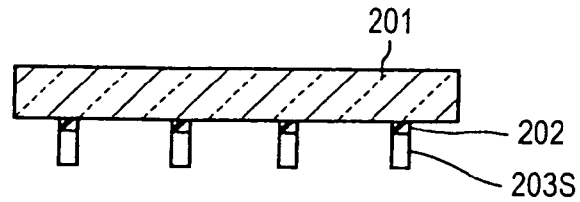

FIG. 2C

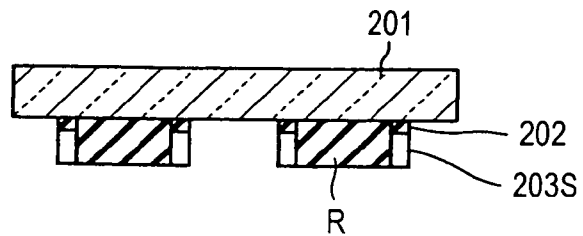

FIG. 2D

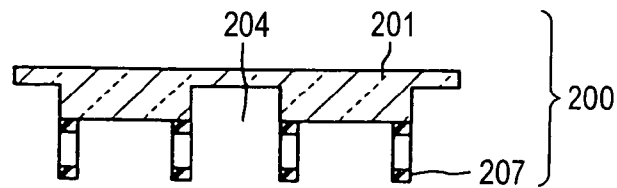

FIG. 3A

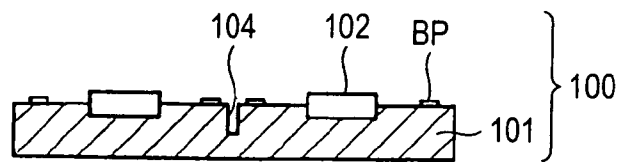

FIG. 3B

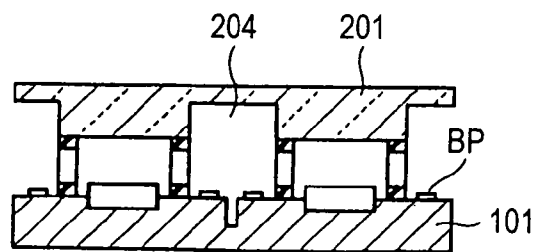

FIG. 3C

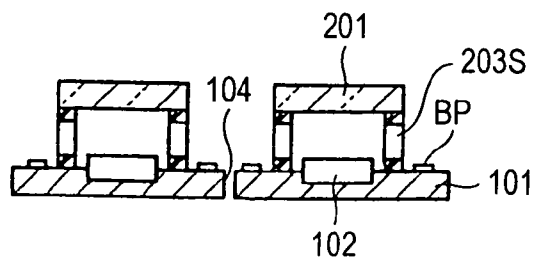

FIG. 4A

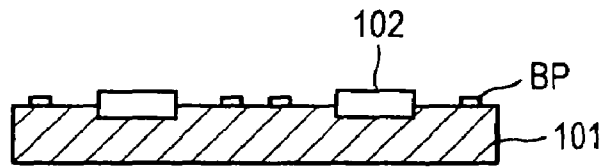

FIG. 4B

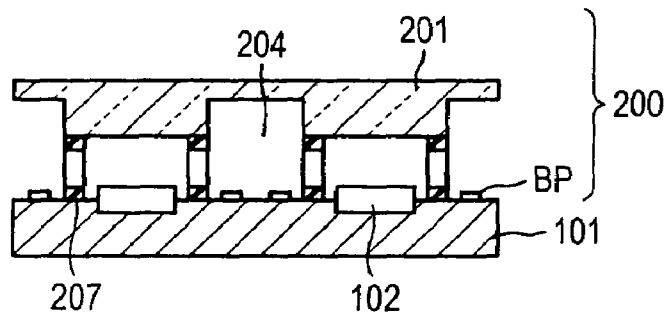

FIG. 4C

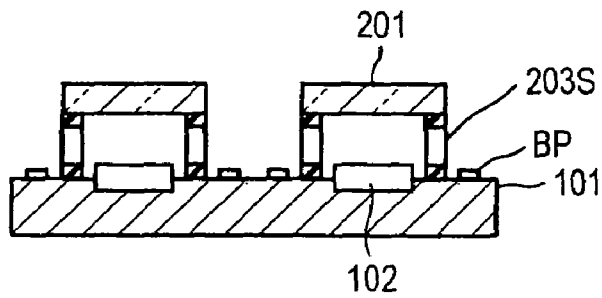
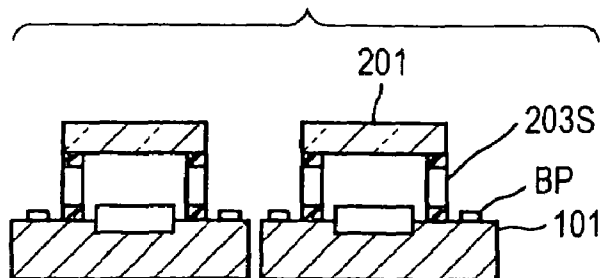

FIG. 4D



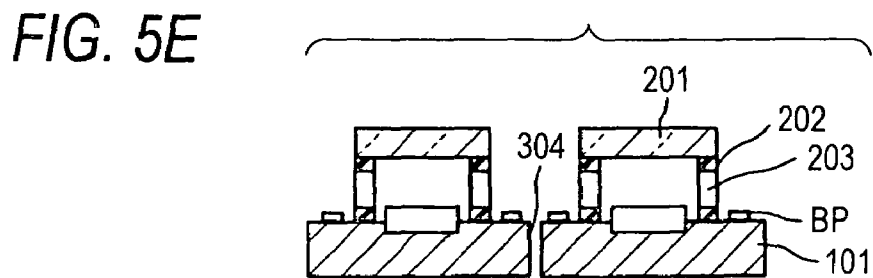
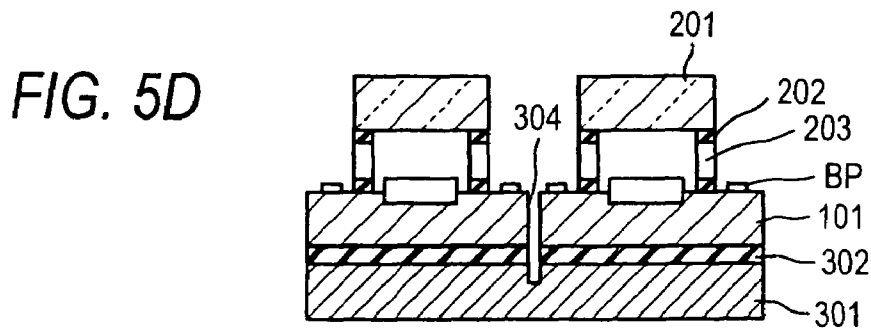
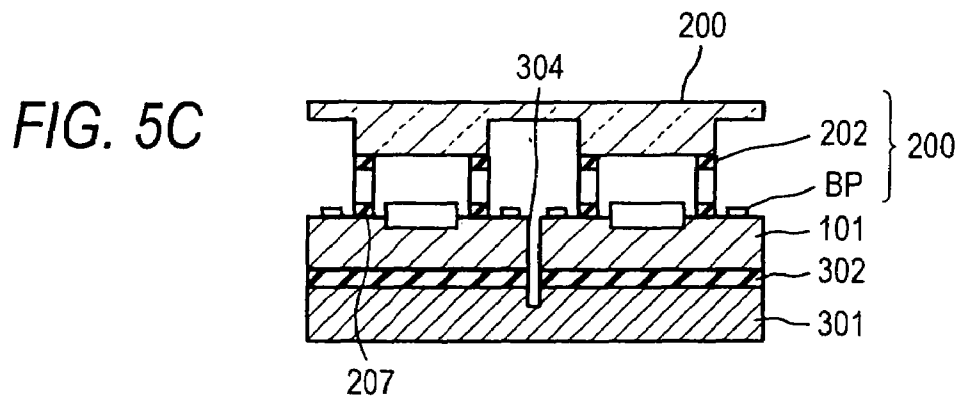
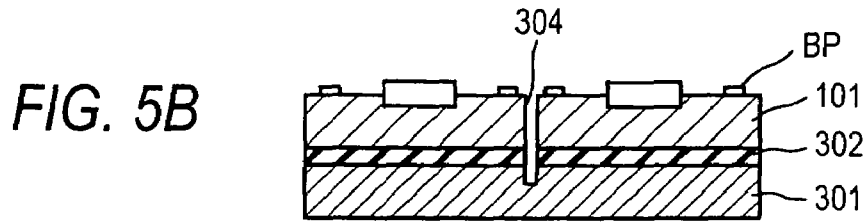
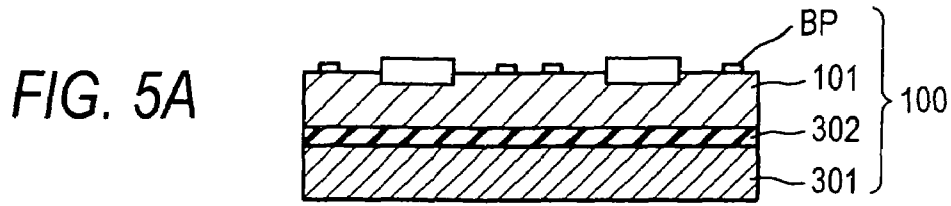

FIG. 6A

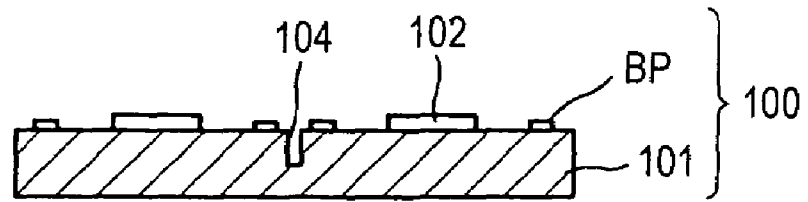

FIG. 6B

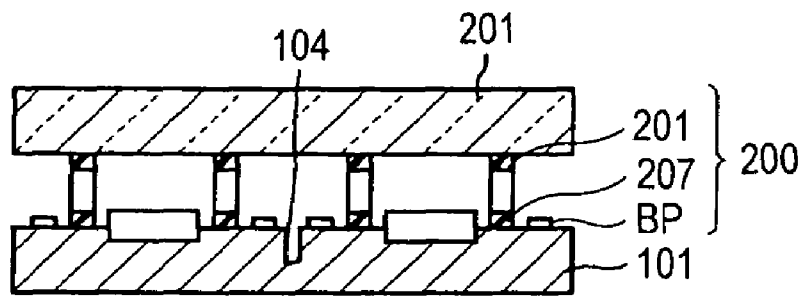

FIG. 6C

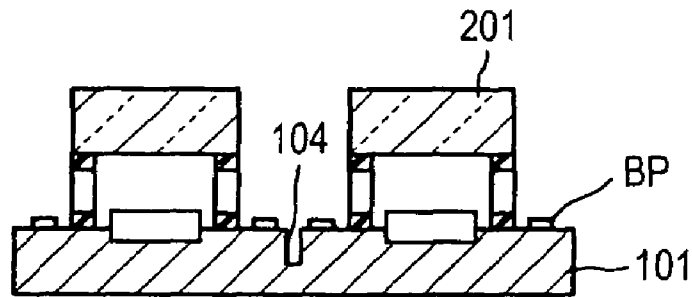

FIG. 6D

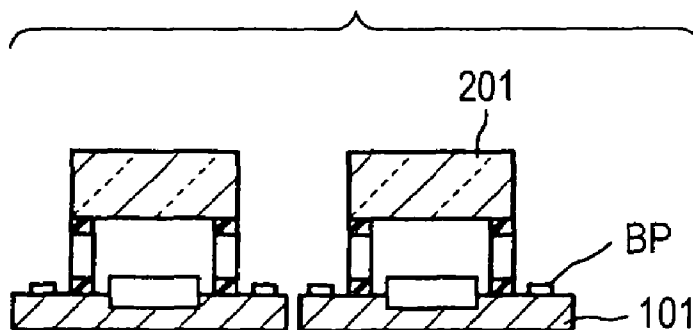

FIG. 7A

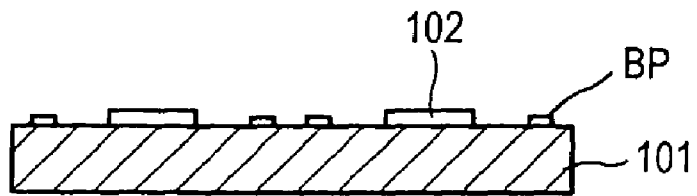

FIG. 7B

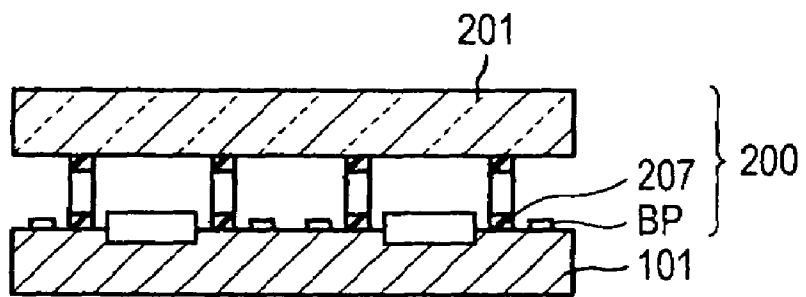

FIG. 7C

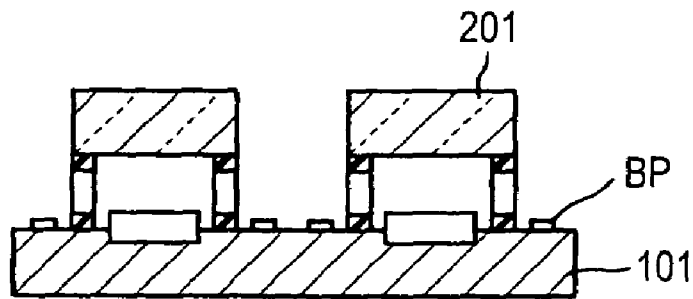
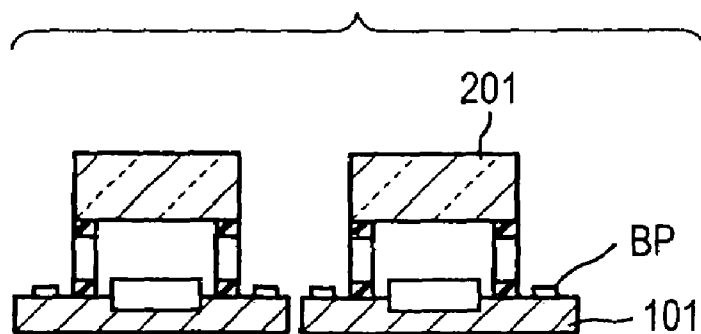

FIG. 7D



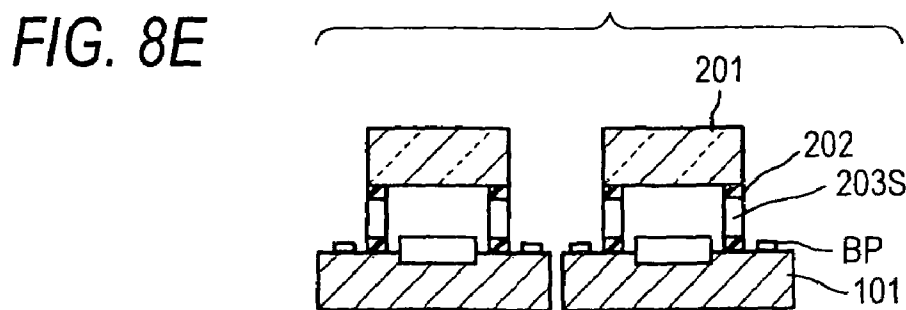
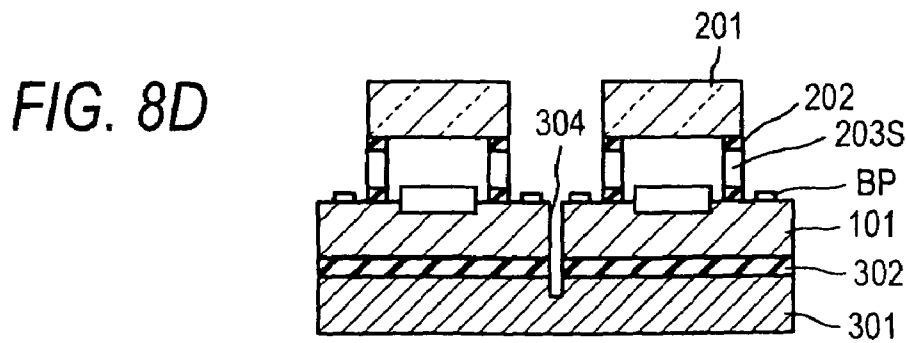
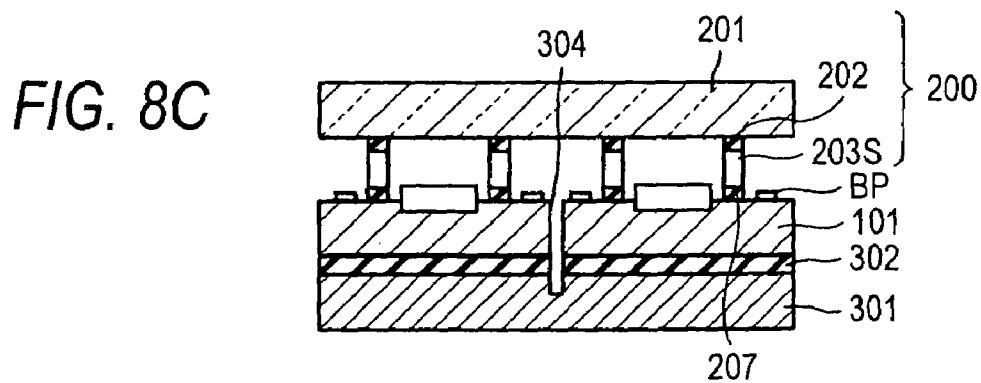
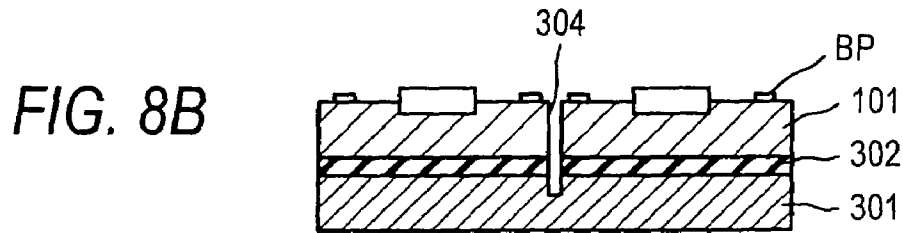
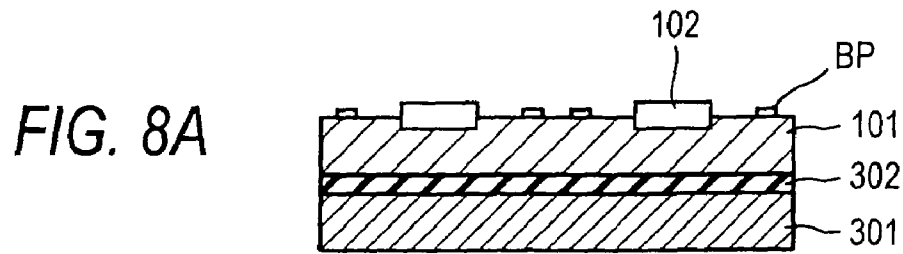

FIG. 9A

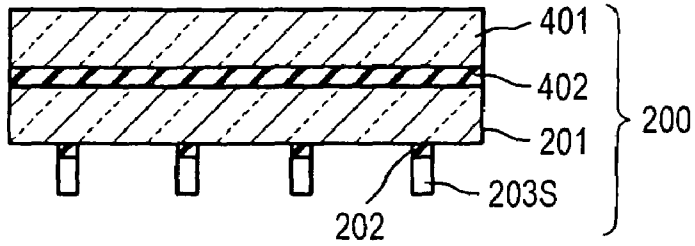

FIG. 9B

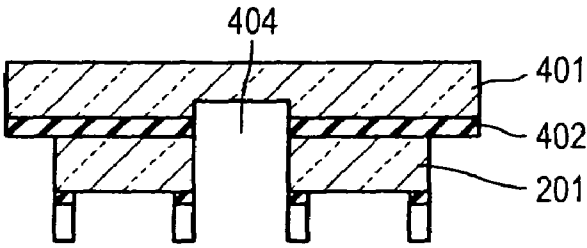

FIG. 9C

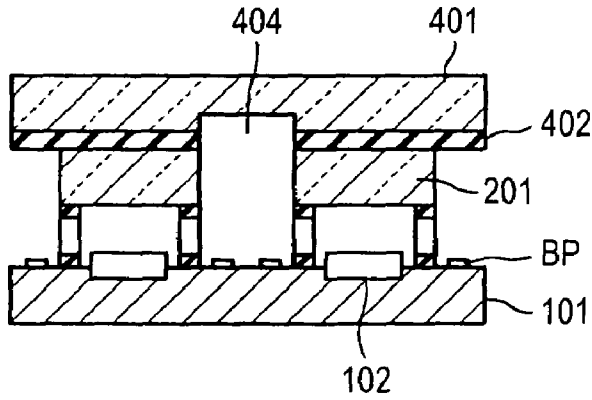

FIG. 9D

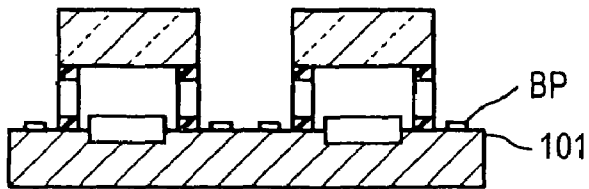

FIG. 9E

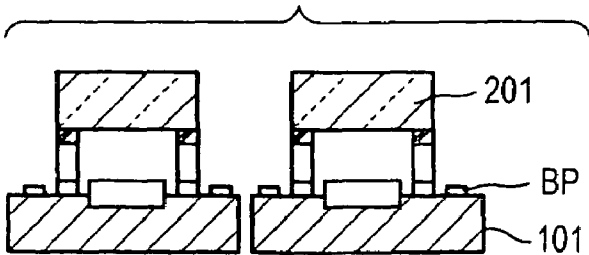

FIG. 10A

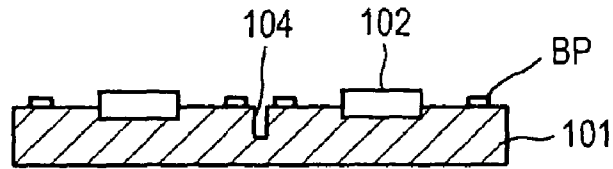

FIG. 10B

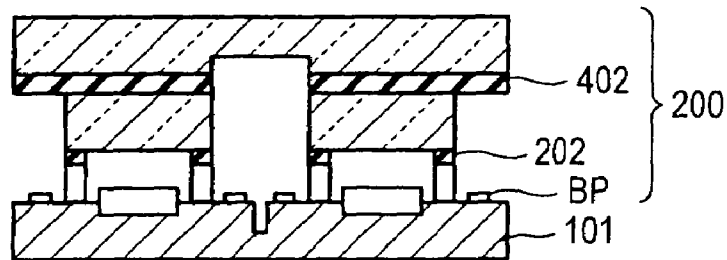

FIG. 10C

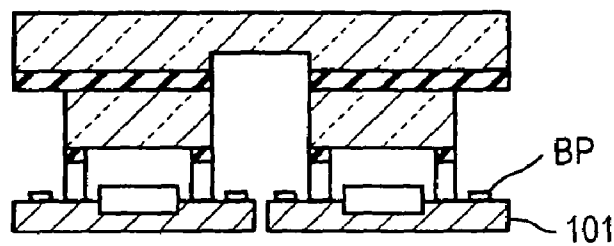

FIG. 10D

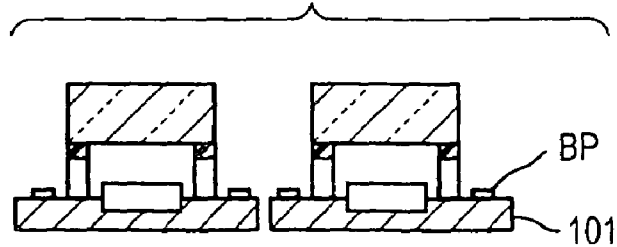

FIG. 11A

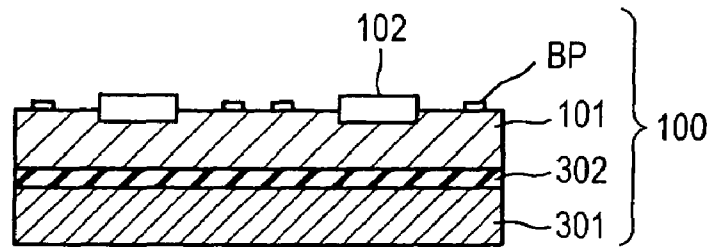

FIG. 11B

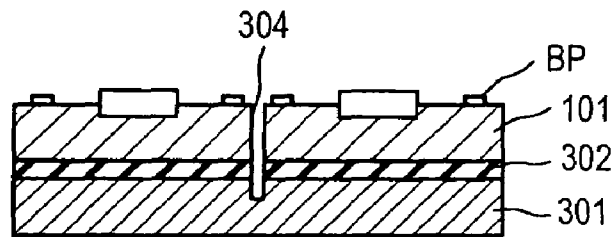

FIG. 11C

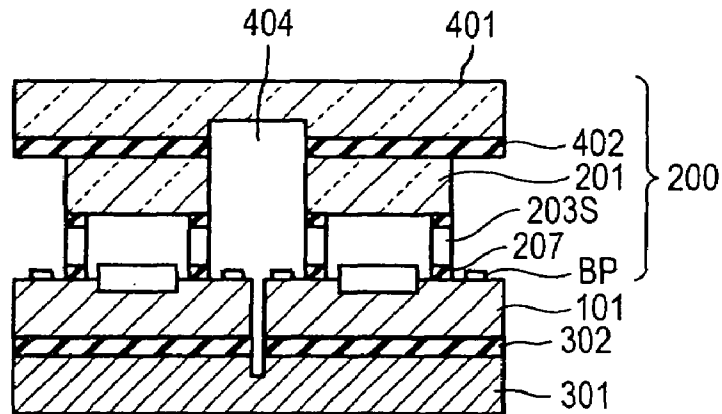
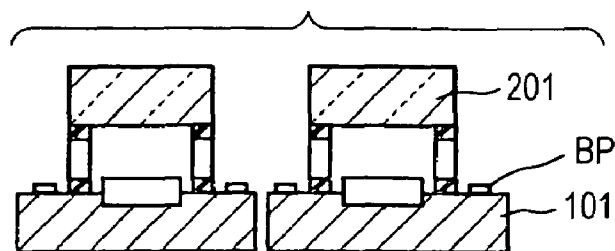

FIG. 11D



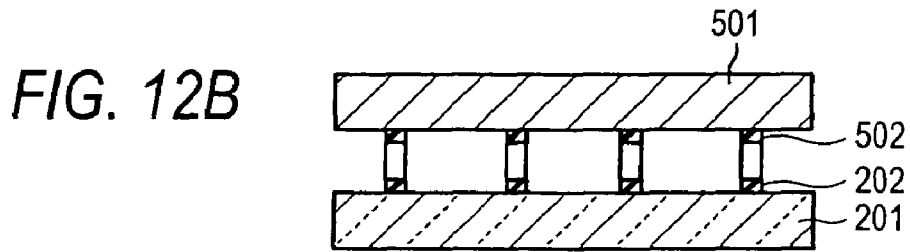
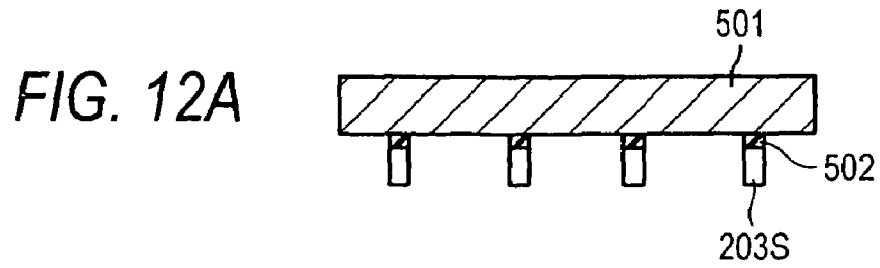

FIG. 13

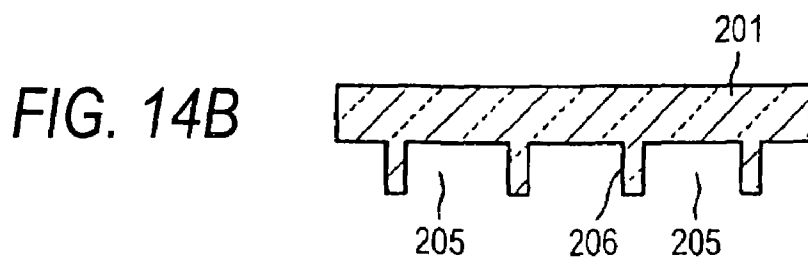
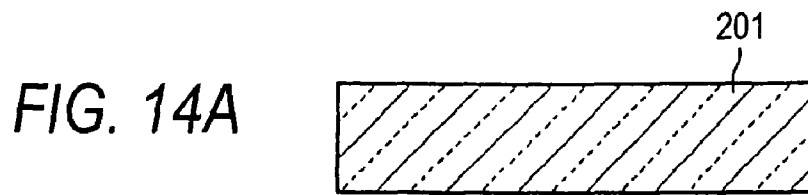
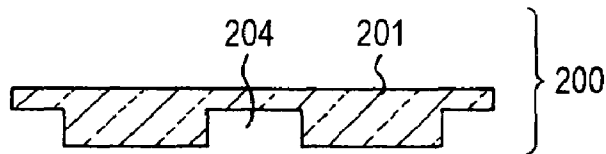

FIG. 15A

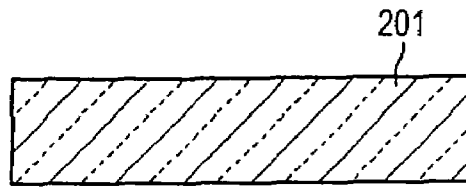

FIG. 15B

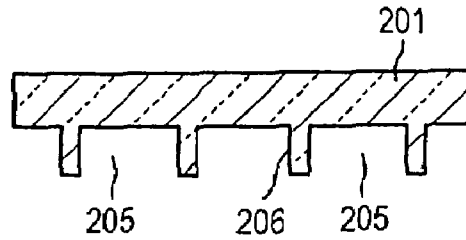

FIG. 15C

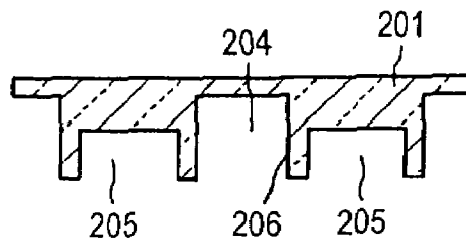

FIG. 16A



FIG. 16B

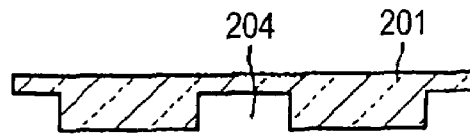

FIG. 16C

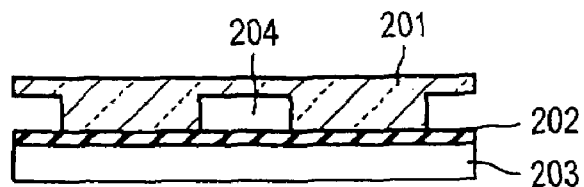

FIG. 16D

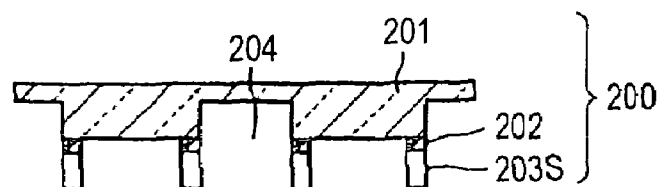

FIG. 17A

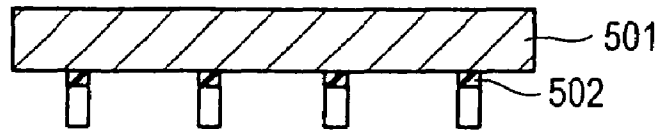

FIG. 17B

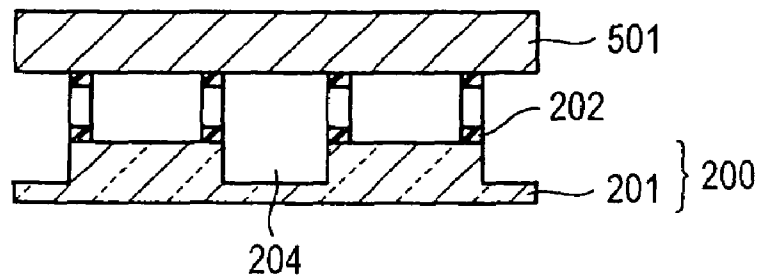

FIG. 17C

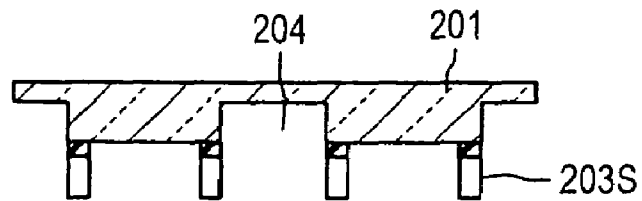

FIG. 18

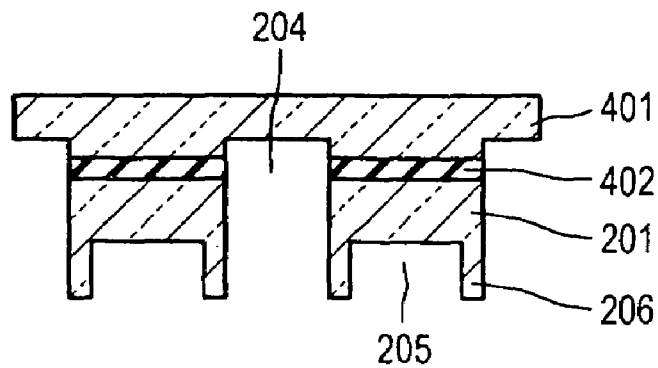

FIG. 19A

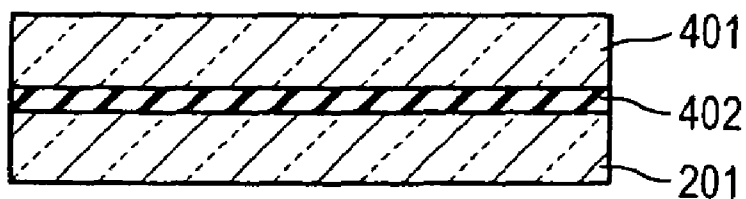

FIG. 19B

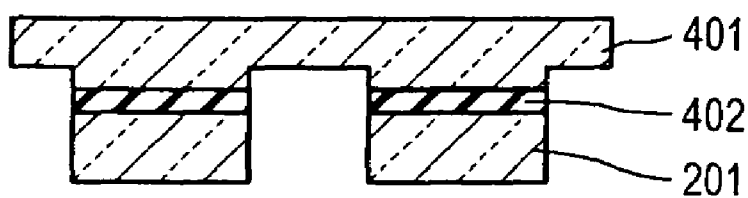

FIG. 19C

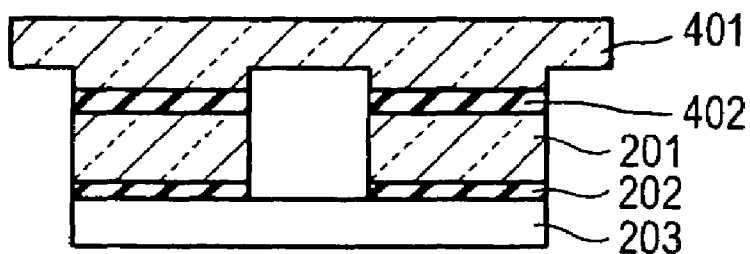

FIG. 19D

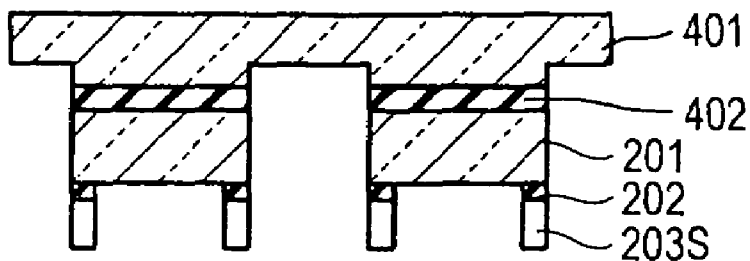

FIG. 20A

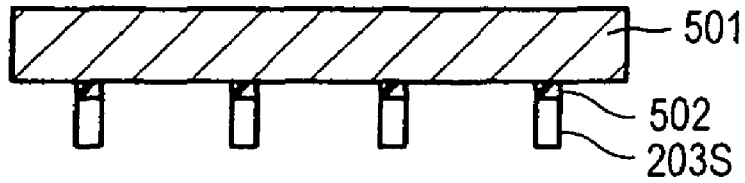

FIG. 20B

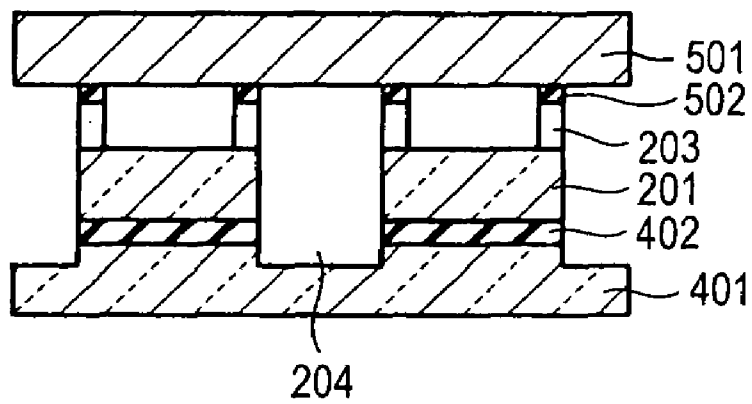

FIG. 20C

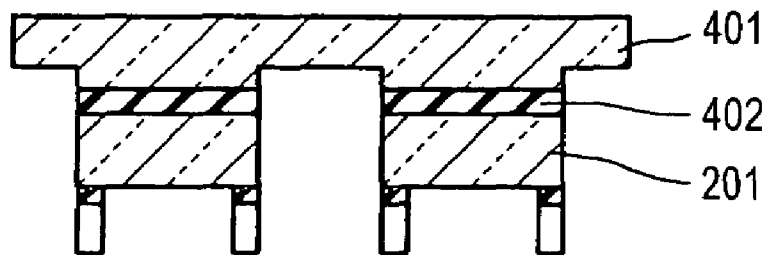

FIG. 21A



FIG. 21B

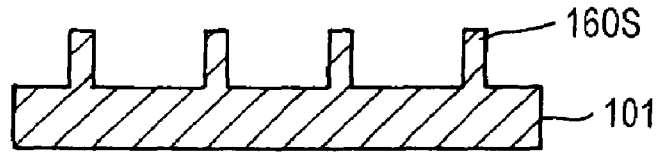

FIG. 21C

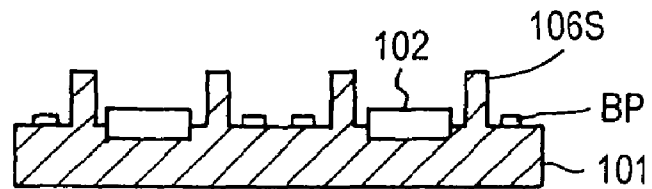

FIG. 21D

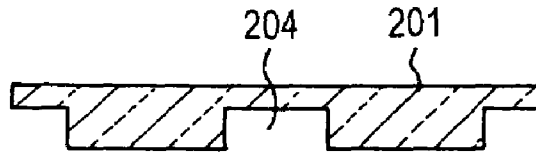

FIG. 21E

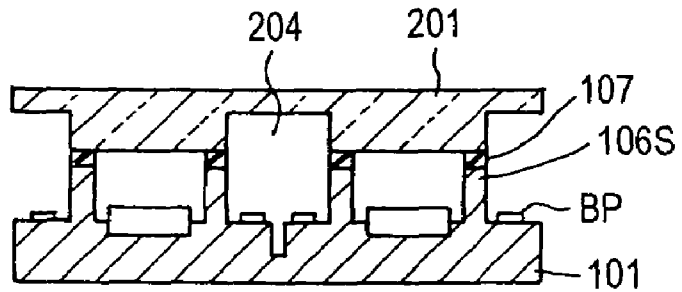

FIG. 21F

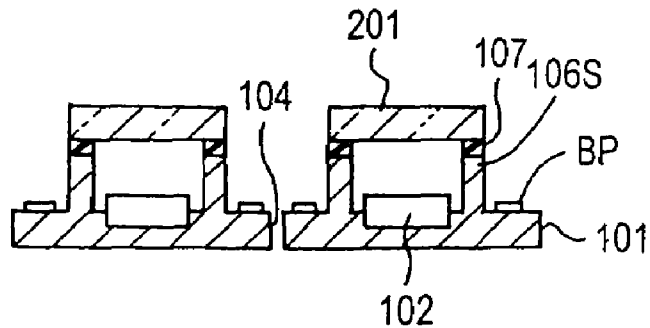

FIG. 22A

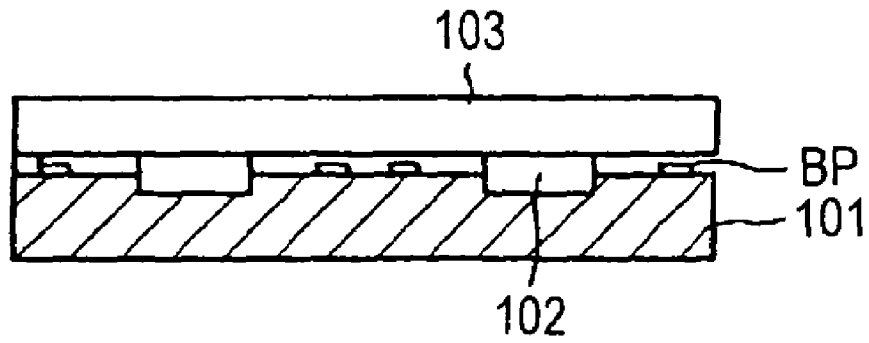

FIG. 22B

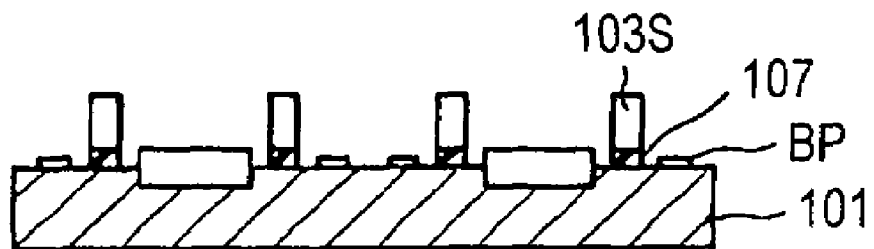

FIG. 22C

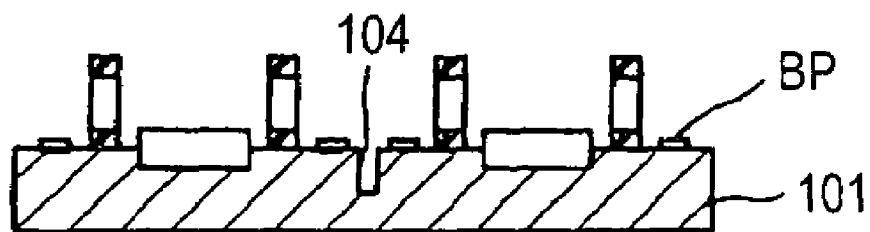

FIG. 23A

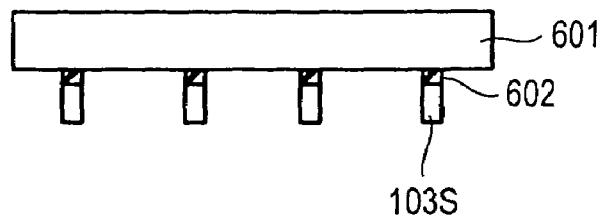

FIG. 23B

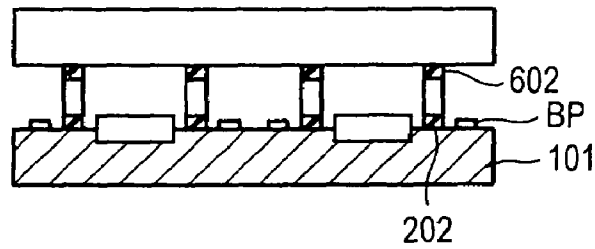

FIG. 23C



FIG. 23D

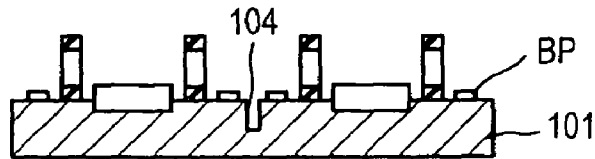

FIG. 24

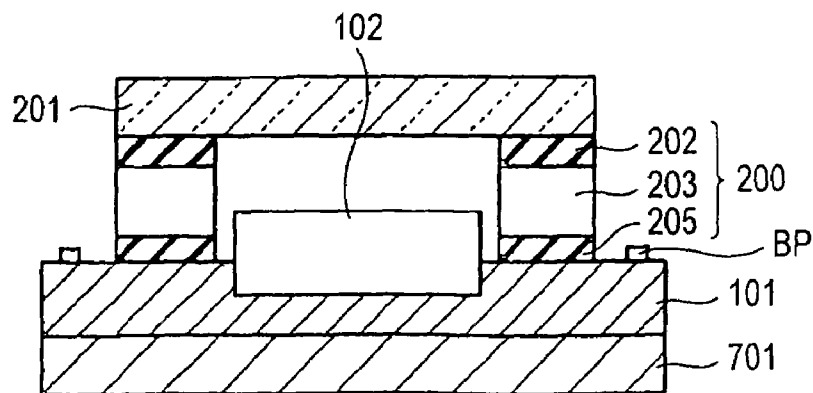

FIG. 25A

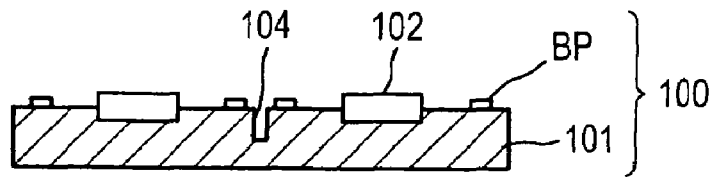

FIG. 25B

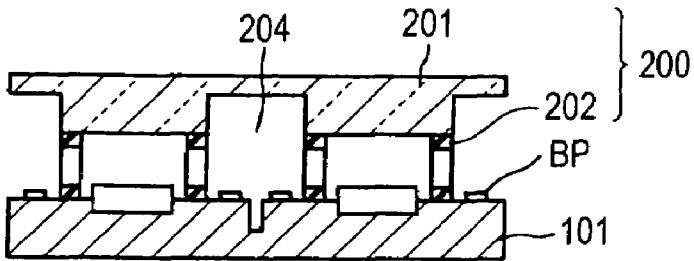

FIG. 25C

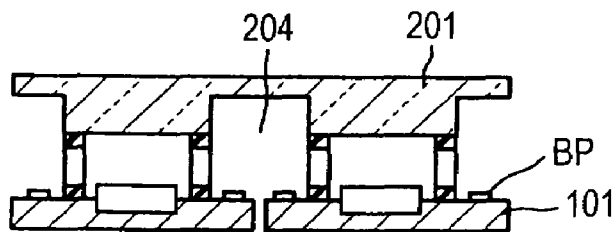

FIG. 25D

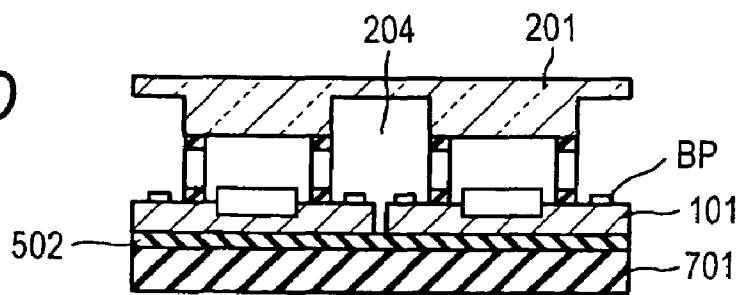

FIG. 25E

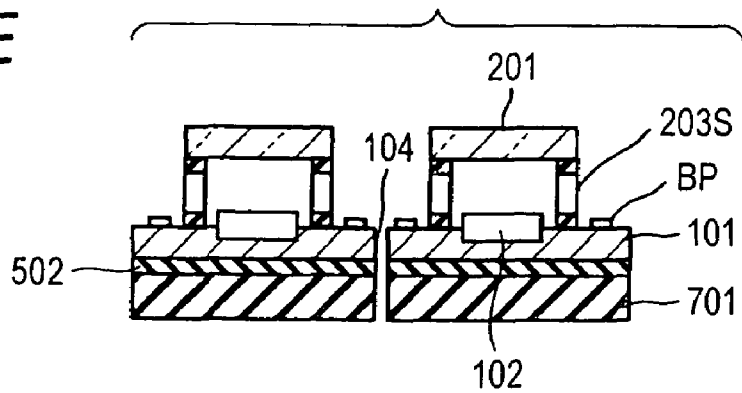

FIG. 26

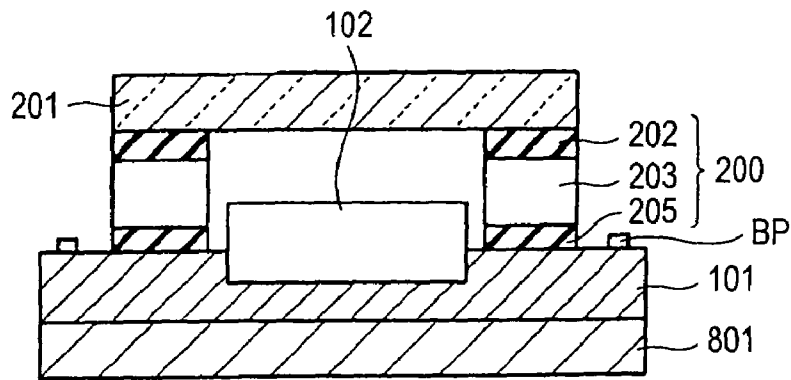

FIG. 27A

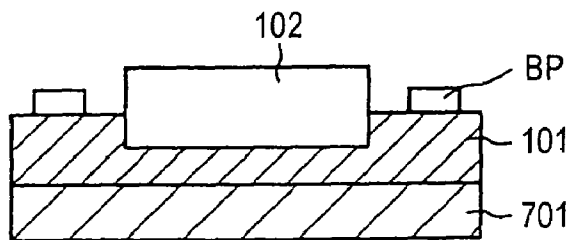

FIG. 27B

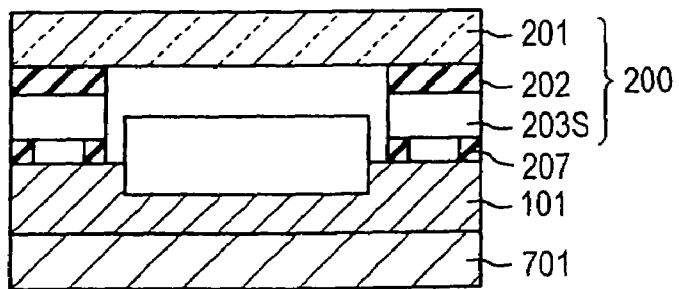

FIG. 27C

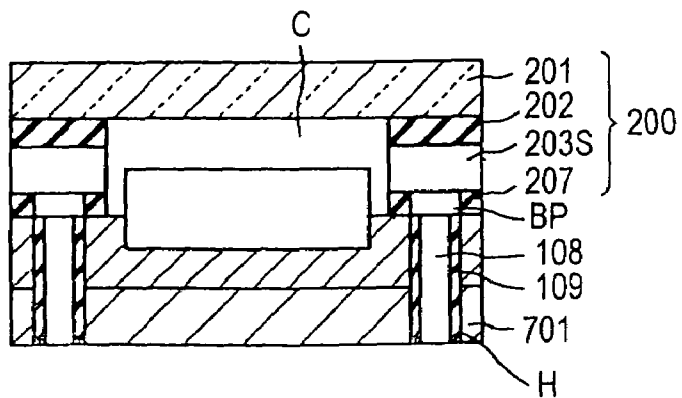

FIG. 28A

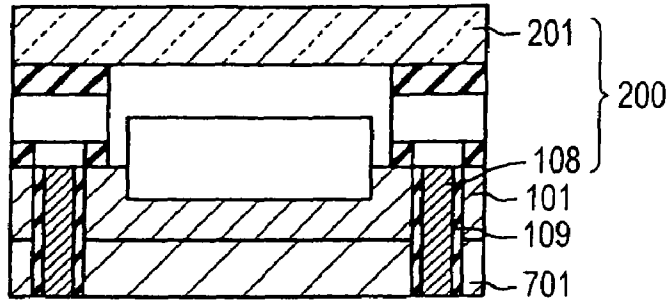

FIG. 28B

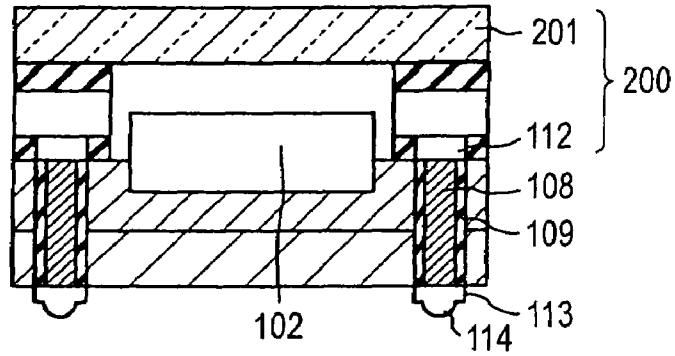

FIG. 28C

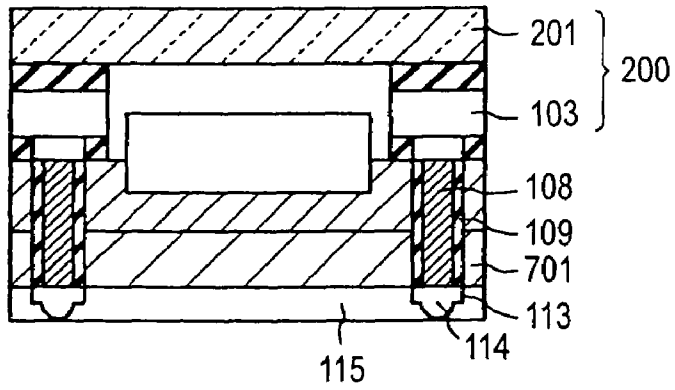
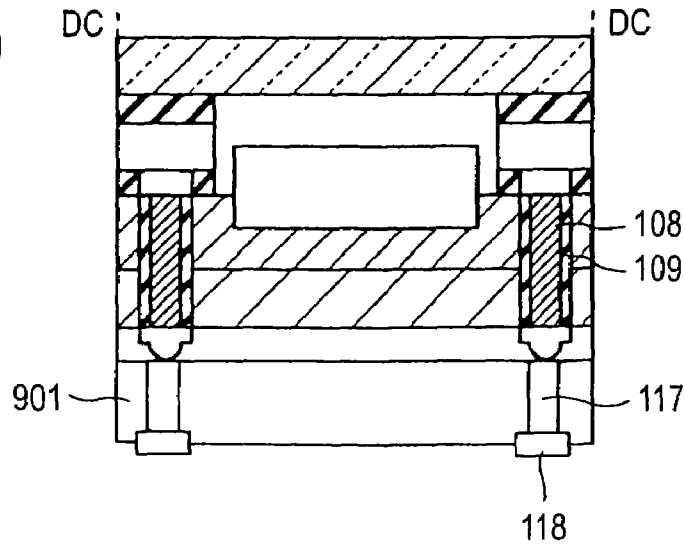

FIG. 28D



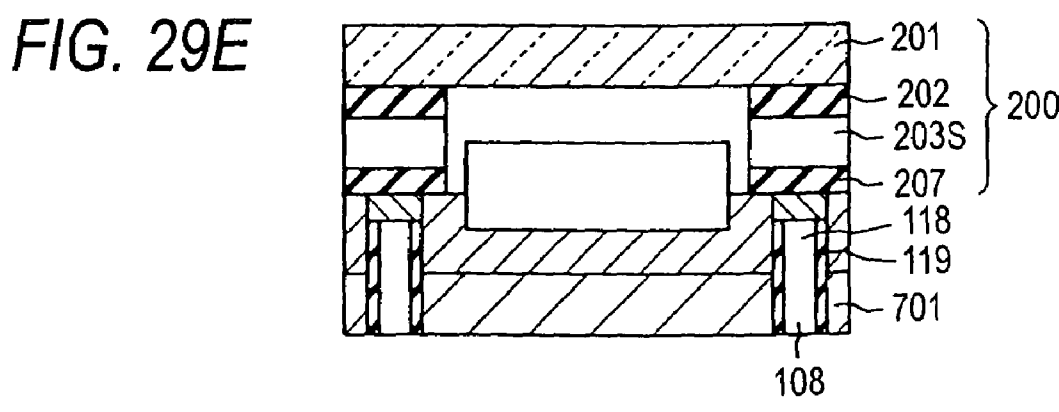
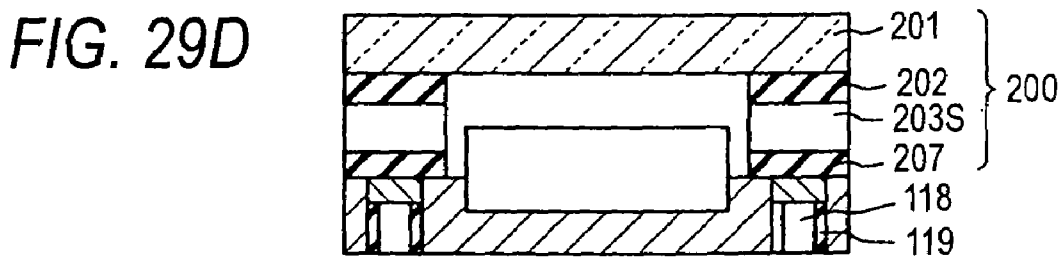
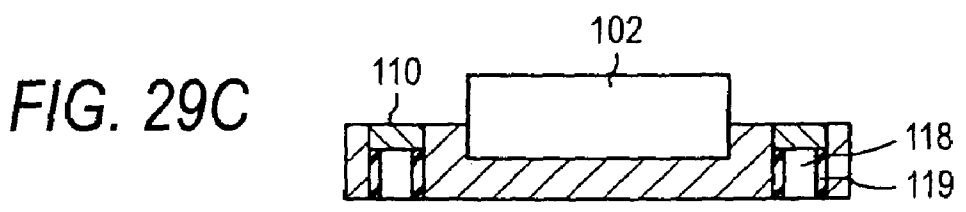
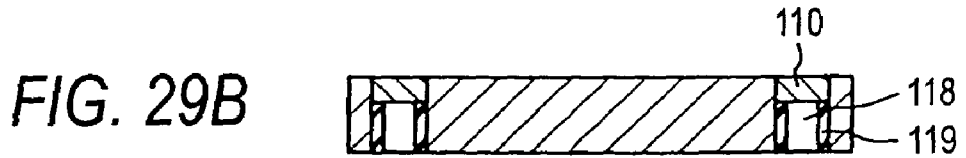
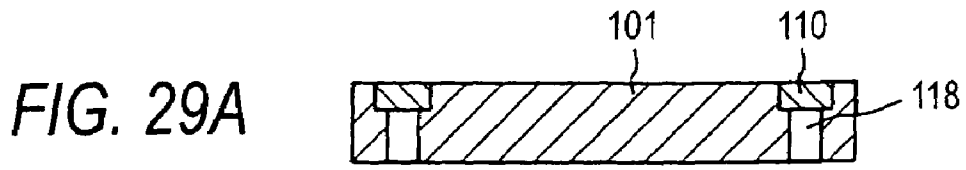

FIG. 30A

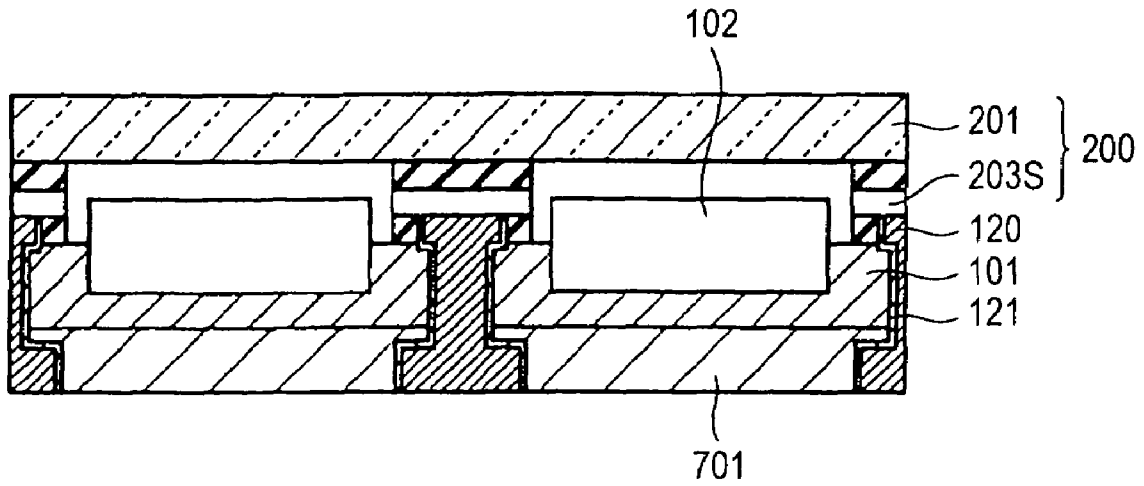

FIG. 30B

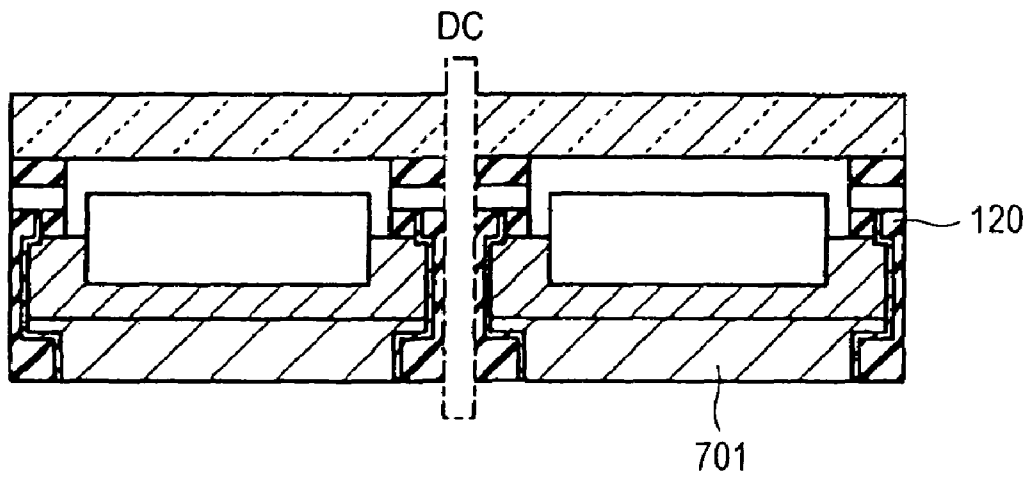

FIG. 31

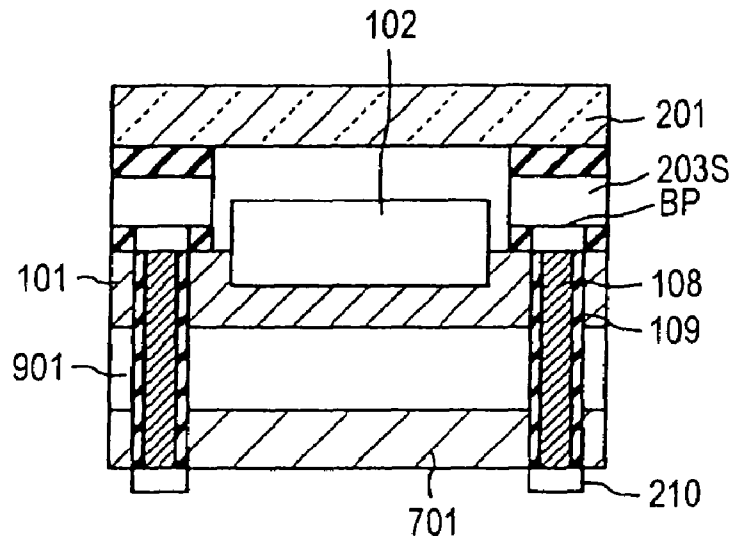

FIG. 32

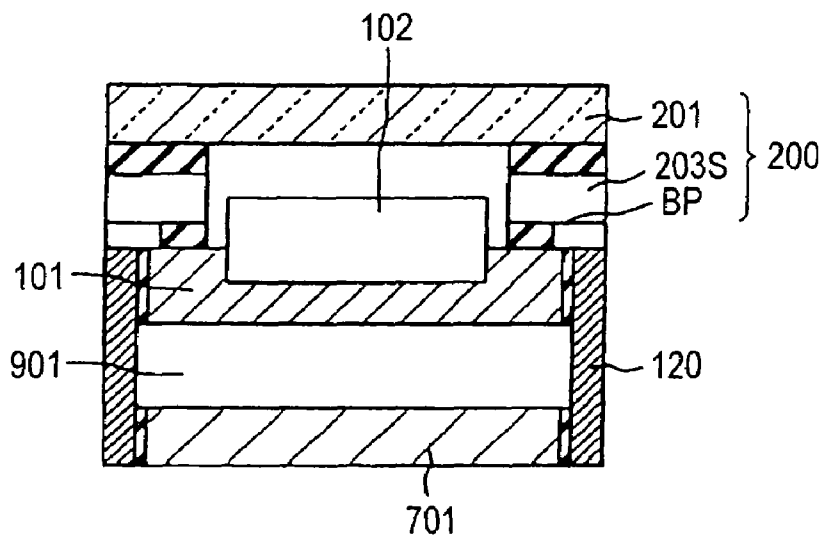
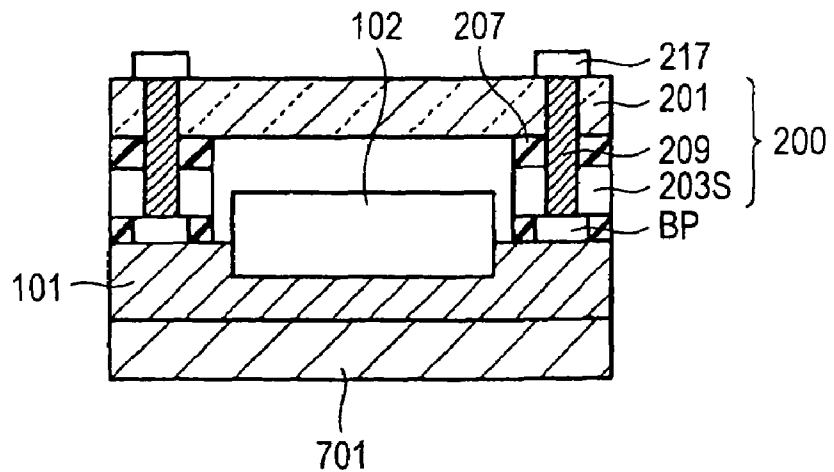

FIG. 33



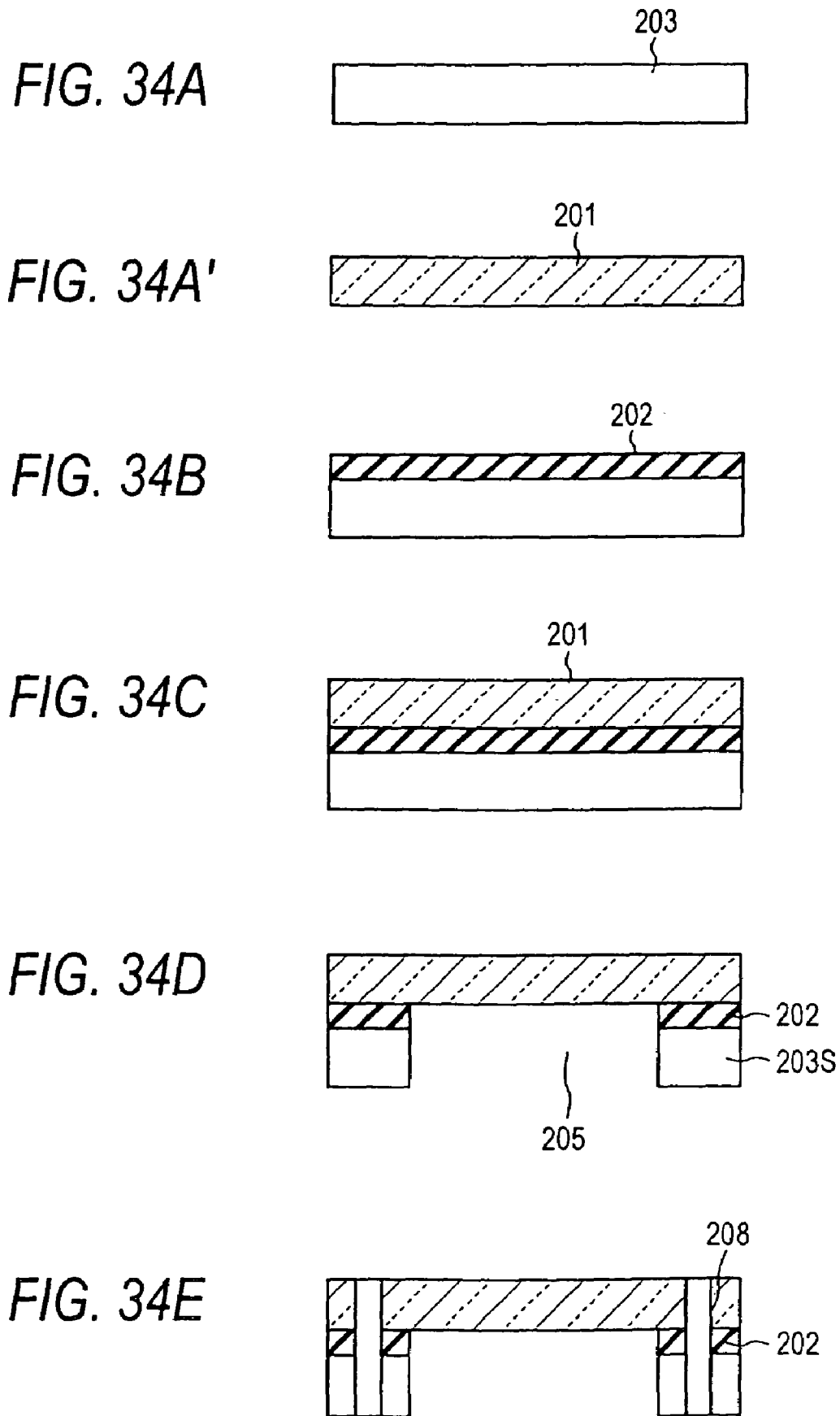

FIG. 35A

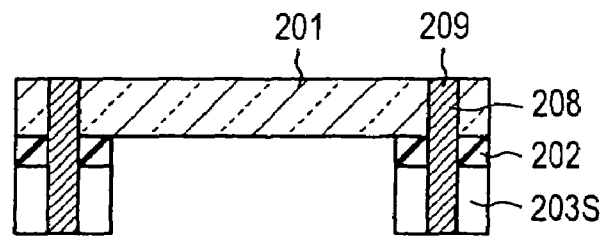

FIG. 35B

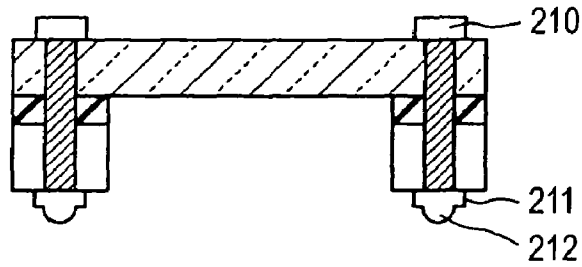

FIG. 35C

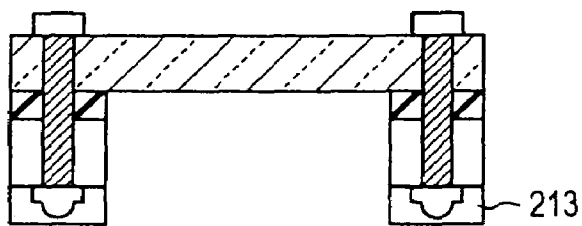

FIG. 35D

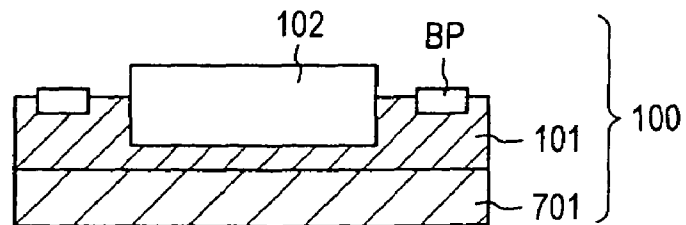

FIG. 35E

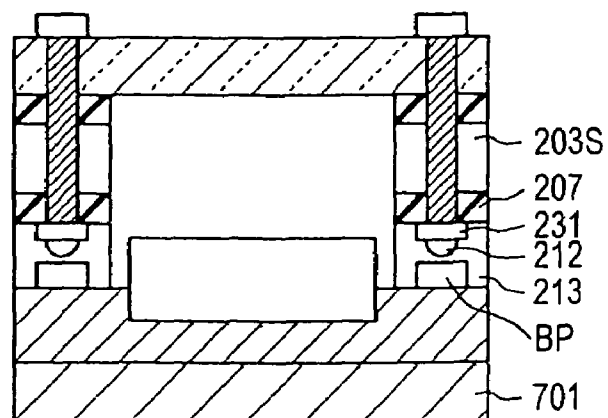

FIG. 36A

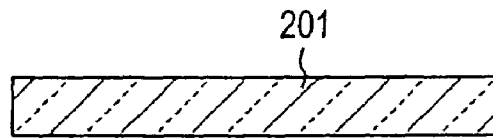

FIG. 36B

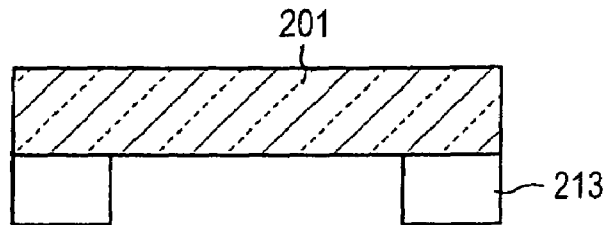

FIG. 36C

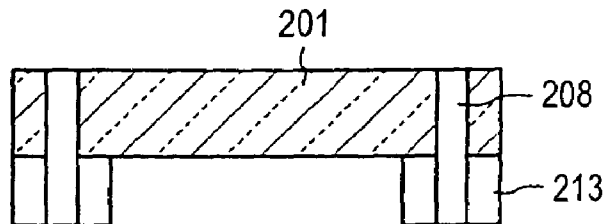

FIG. 37A

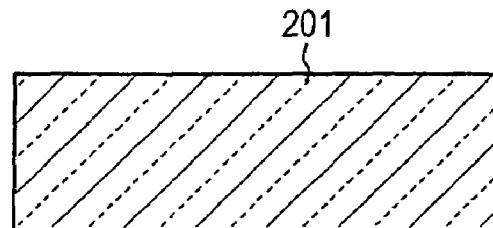

FIG. 37B

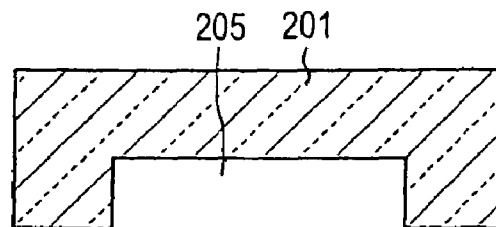
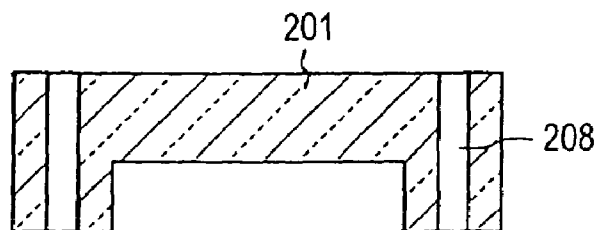

FIG. 37C



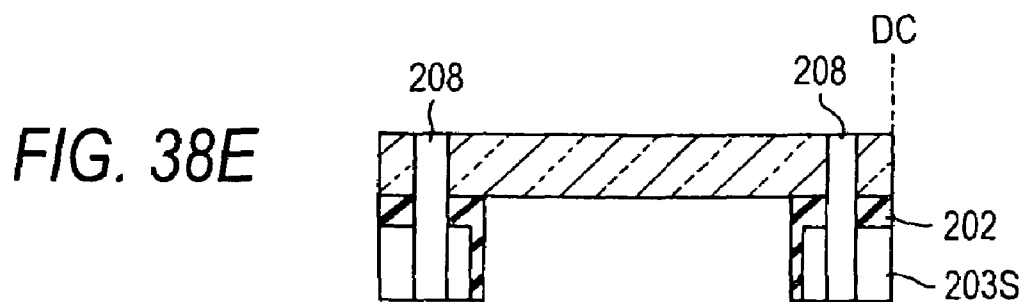
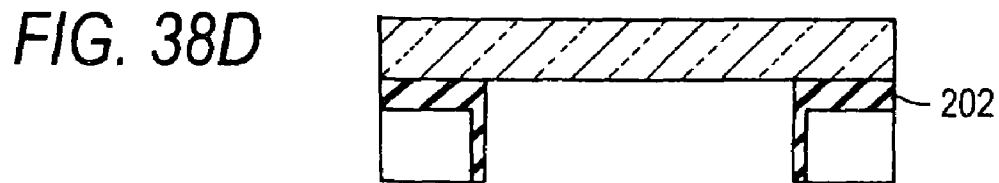
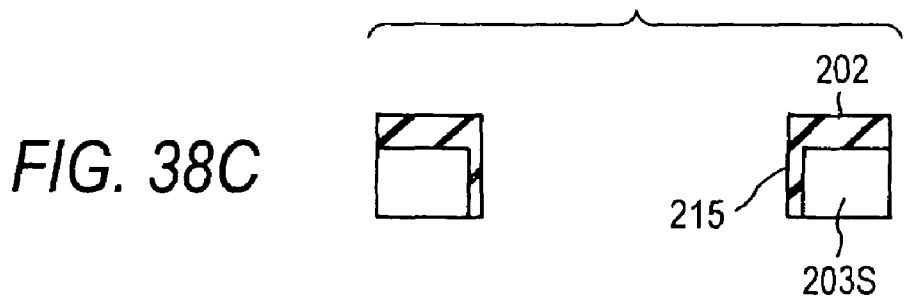
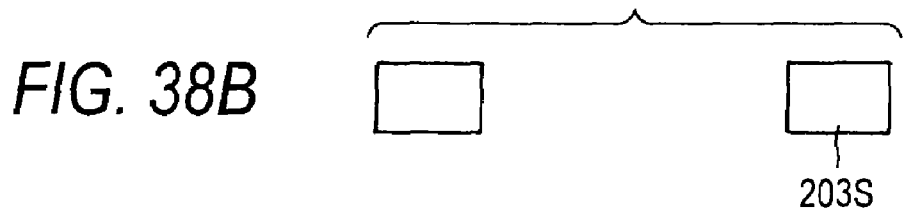

FIG. 39A



FIG. 39A'



FIG. 39B

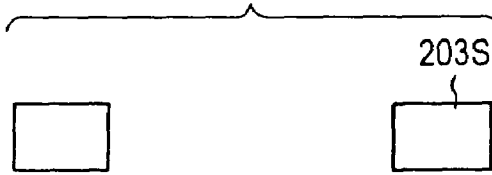

FIG. 39B'

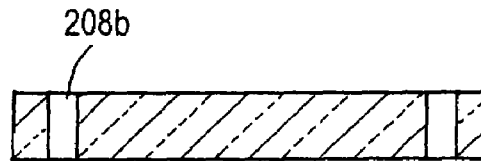

FIG. 39C

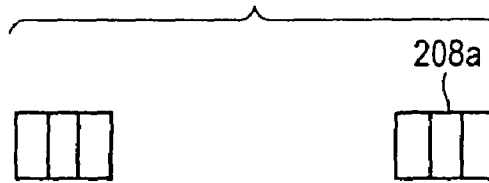

FIG. 39D

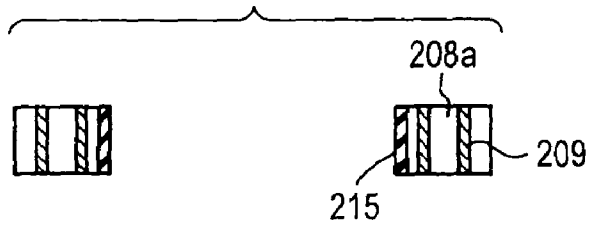

FIG. 39E

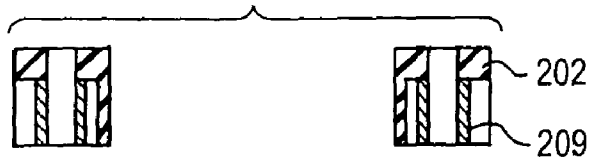

FIG. 39F

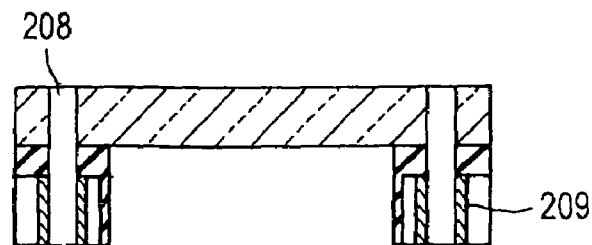

FIG. 40A

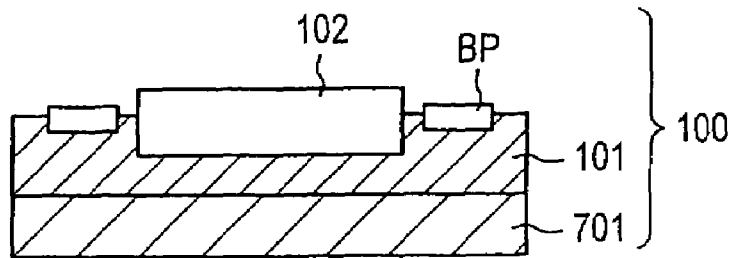

FIG. 40B

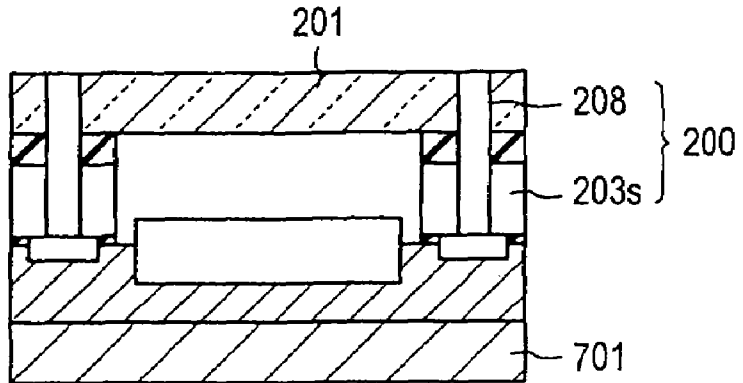

FIG. 40C

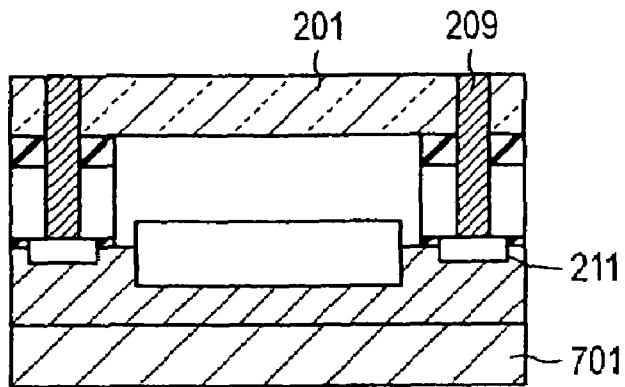

FIG. 40D

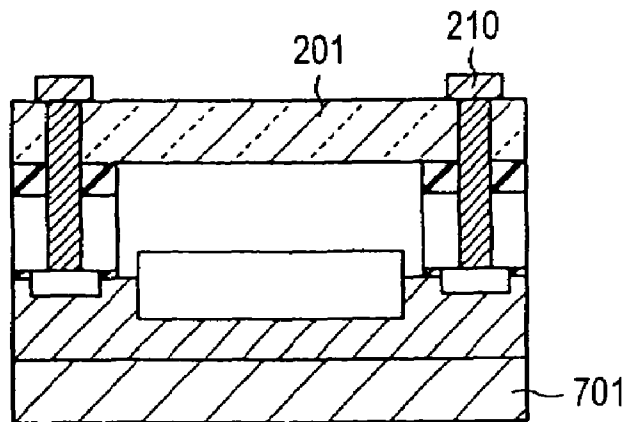

FIG. 41

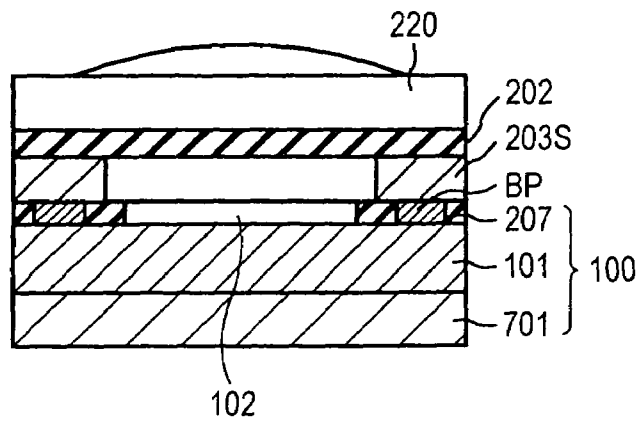

FIG. 42A

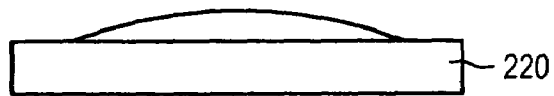

FIG. 42A'

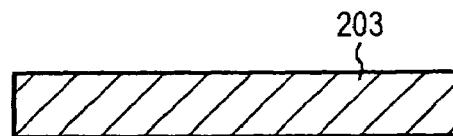

FIG. 42B

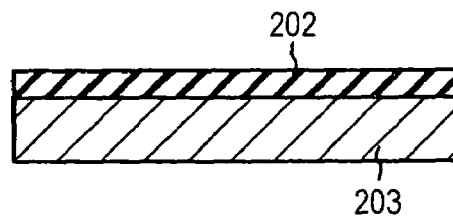

FIG. 42C

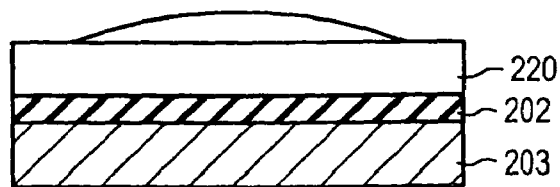

FIG. 42D

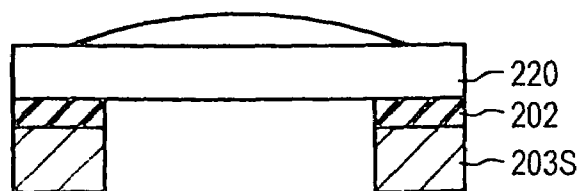

FIG. 43A

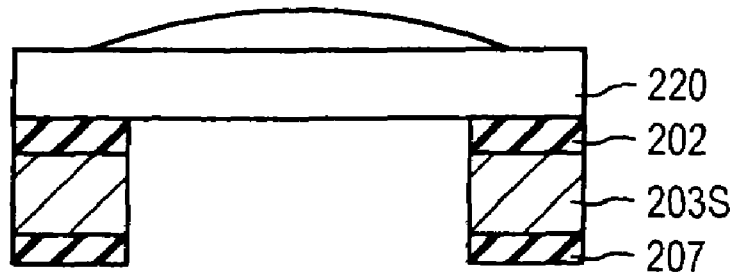

FIG. 43B

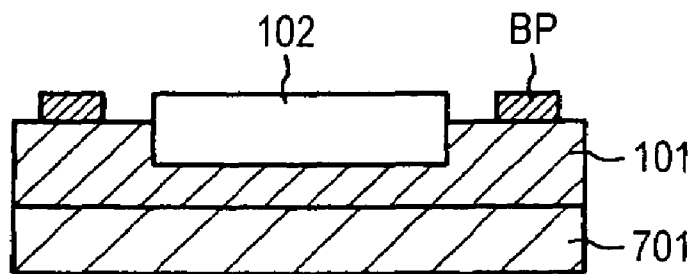

FIG. 43C

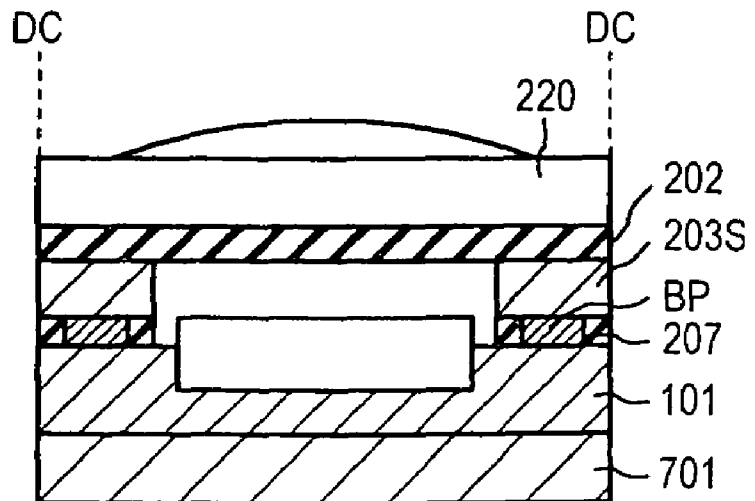

FIG. 44A

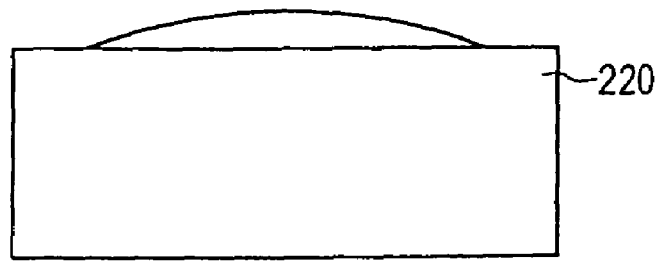

FIG. 44B

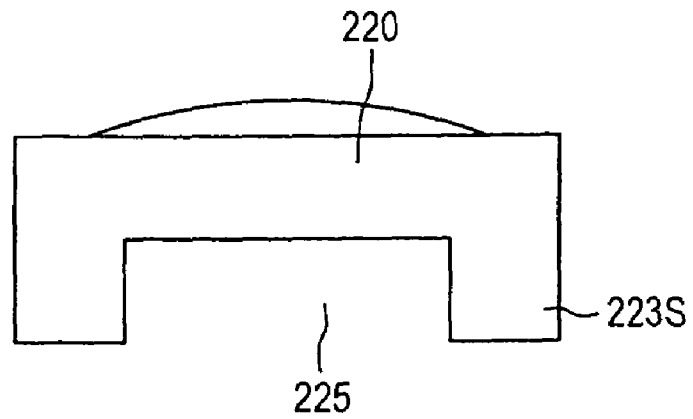

FIG. 45A

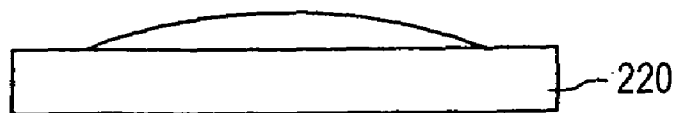

FIG. 45B

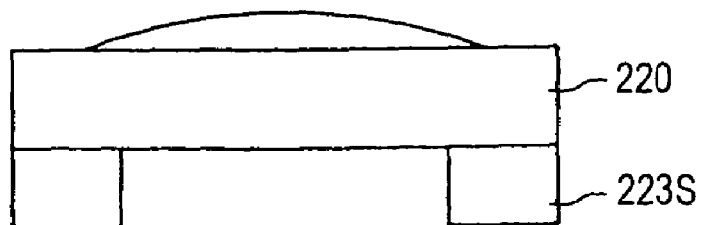

FIG. 46A

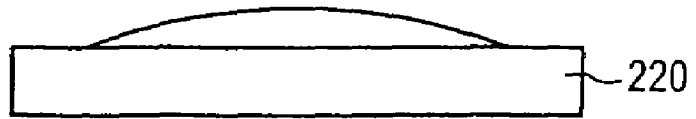

FIG. 46A'

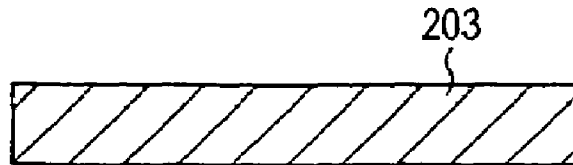

FIG. 46B



FIG. 46C

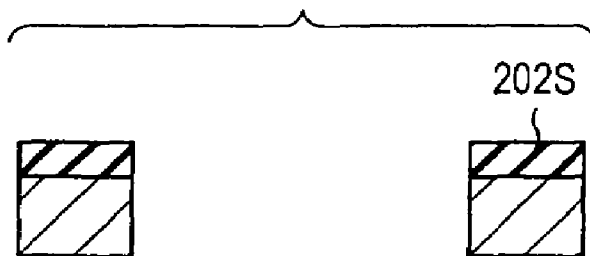

FIG. 46D

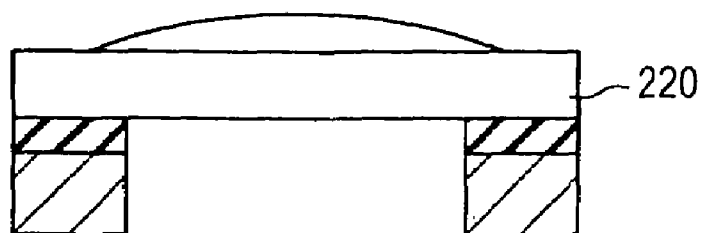

FIG. 47A

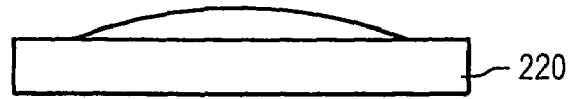

FIG. 47B

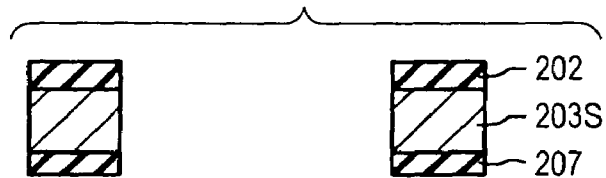

FIG. 47C

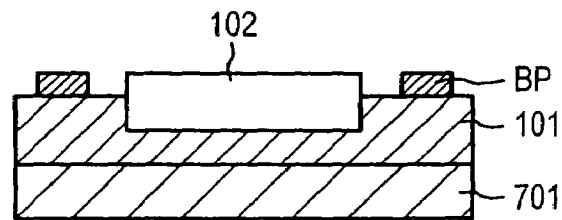

FIG. 47D

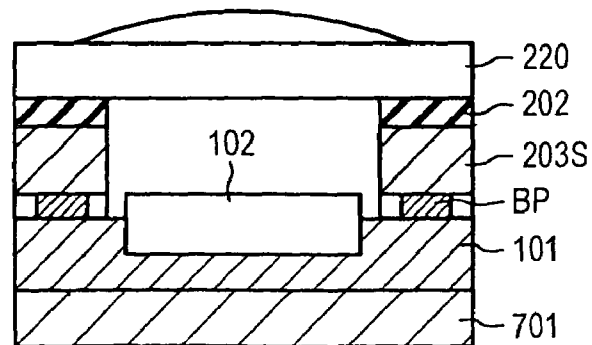

FIG. 48A

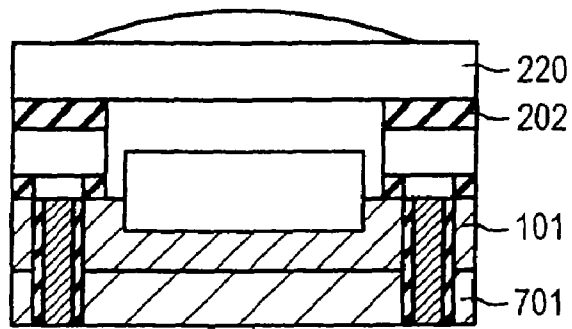

FIG. 48B

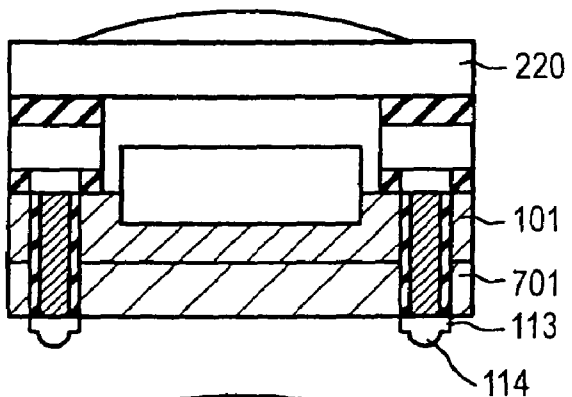

FIG. 48C

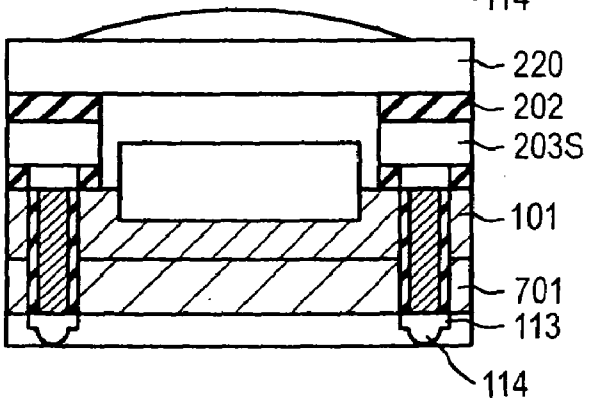

FIG. 48D

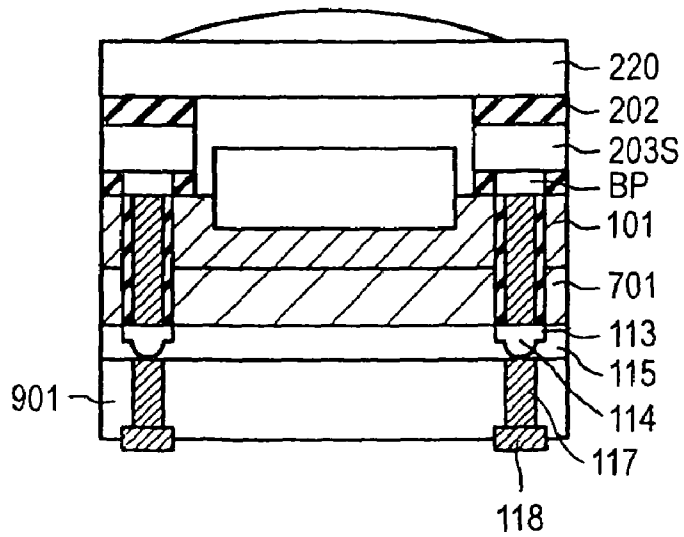

FIG. 49

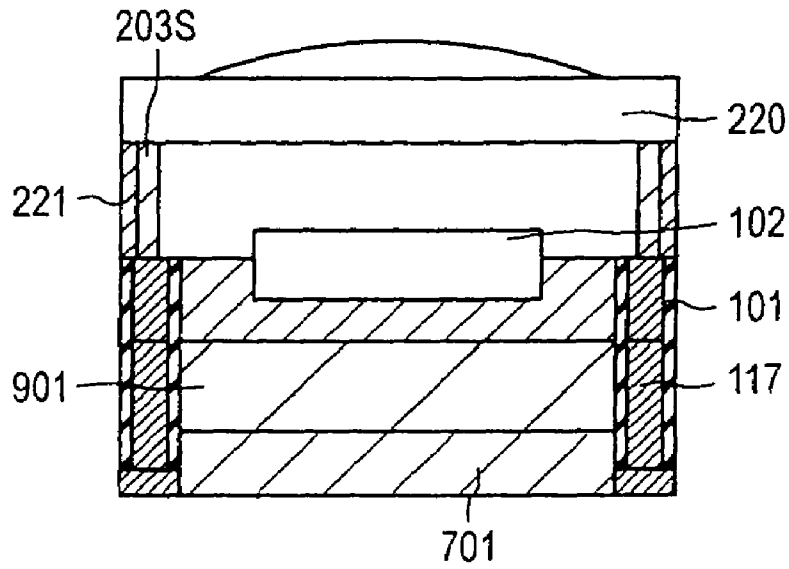

FIG. 50

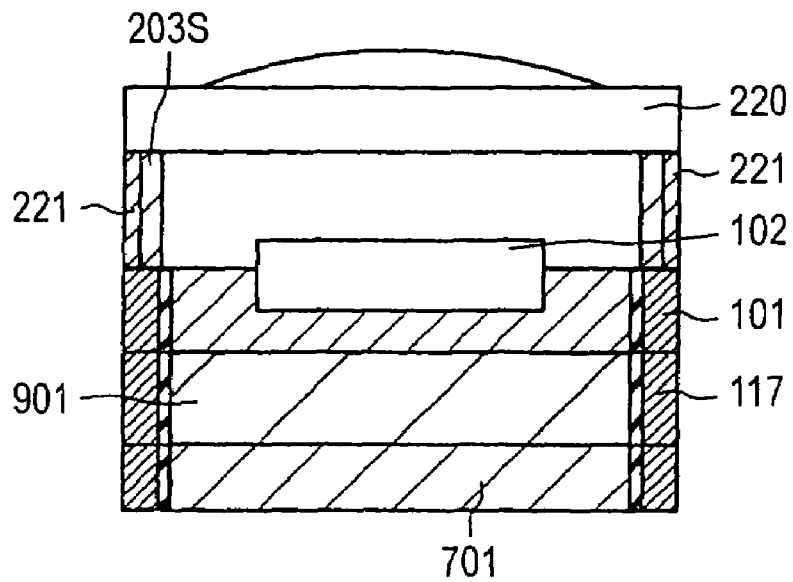

FIG. 51A

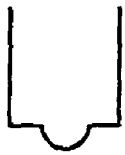

FIG. 51B

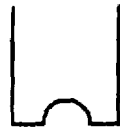

FIG. 51C



FIG. 51D

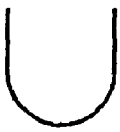

FIG. 51E

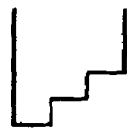

FIG. 51F



FIG. 52

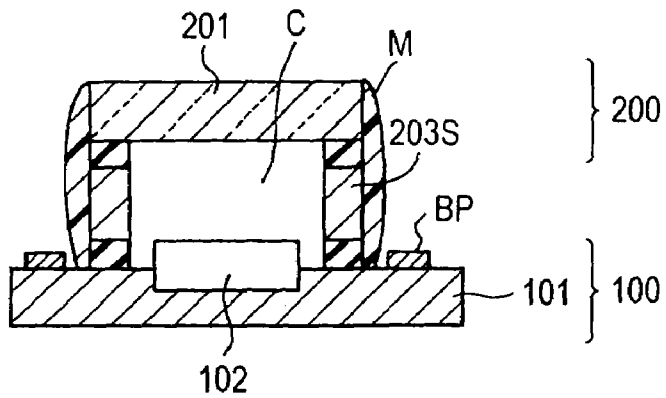

FIG. 53A

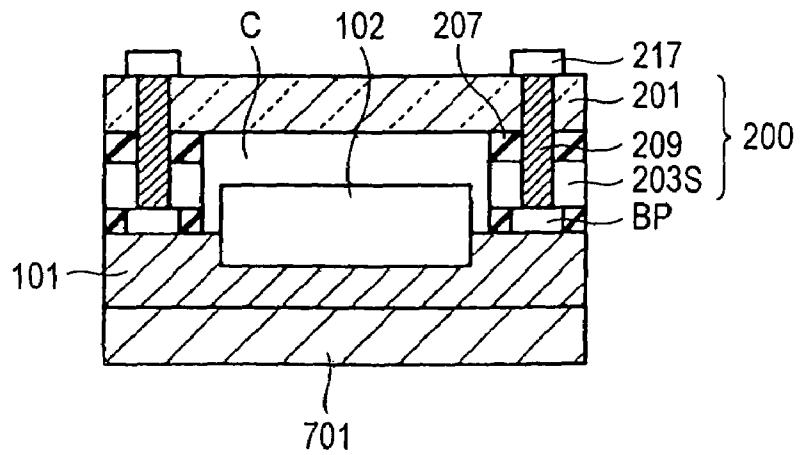

FIG. 54A

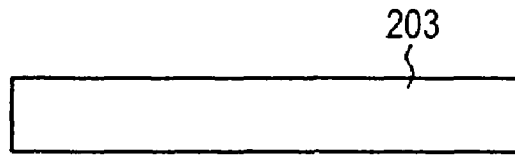

FIG. 54A'

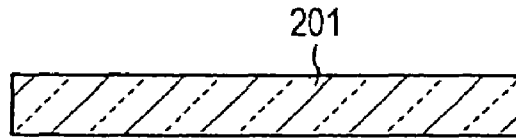

FIG. 54B

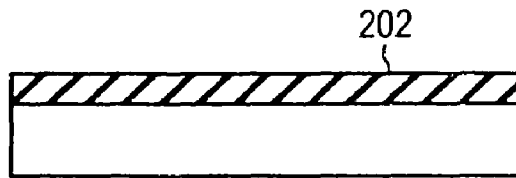

FIG. 54C

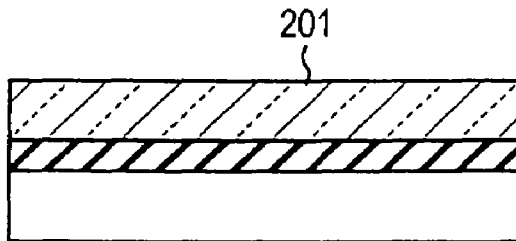

FIG. 54D

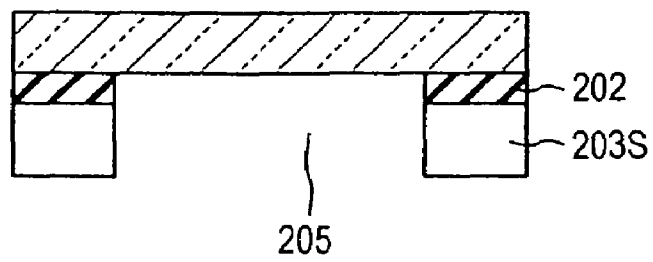

FIG. 54E

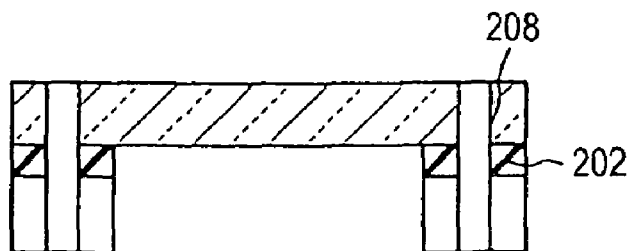

FIG. 55A

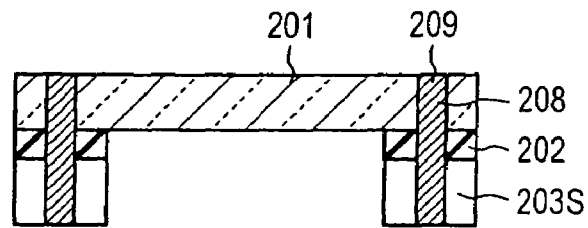

FIG. 55B

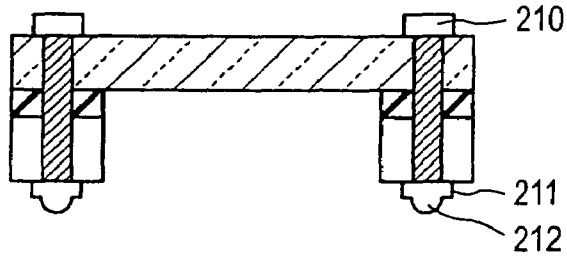

FIG. 55C

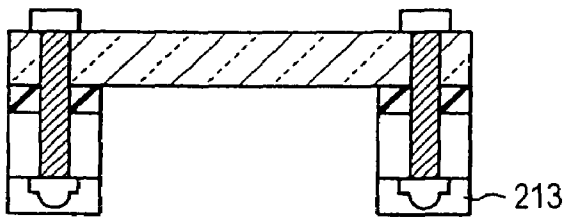

FIG. 55D

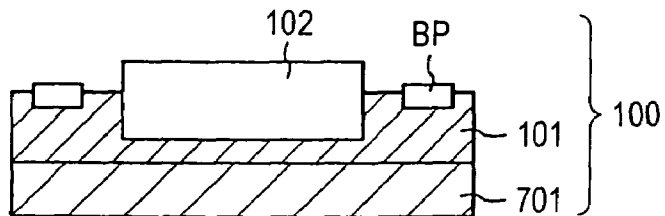

FIG. 55E

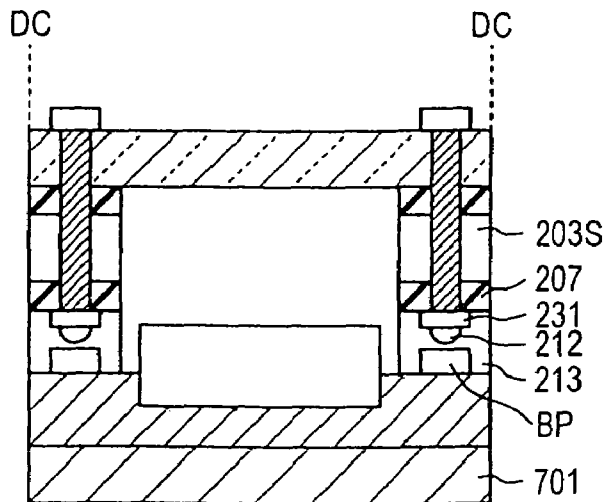

FIG. 56A

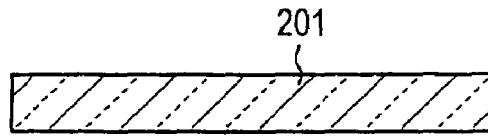

FIG. 56B

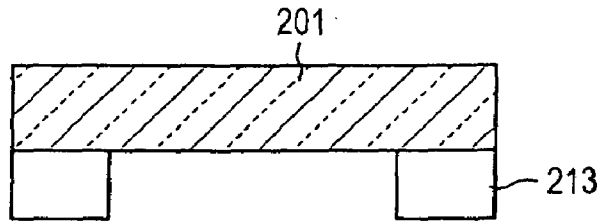

FIG. 56C

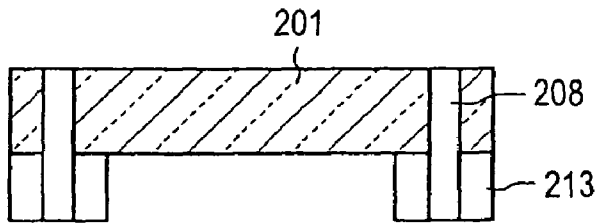

FIG. 57A

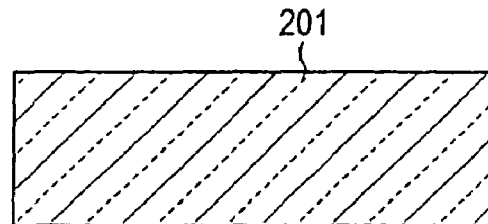

FIG. 57B

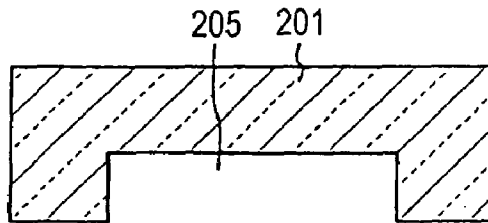
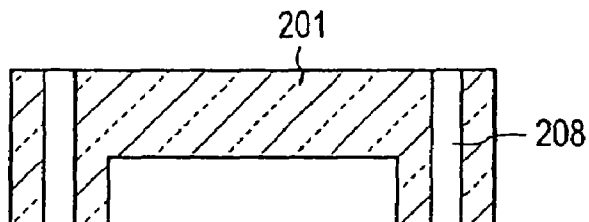

FIG. 57C



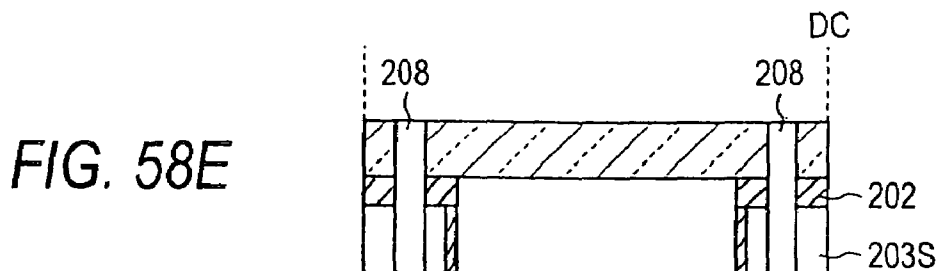
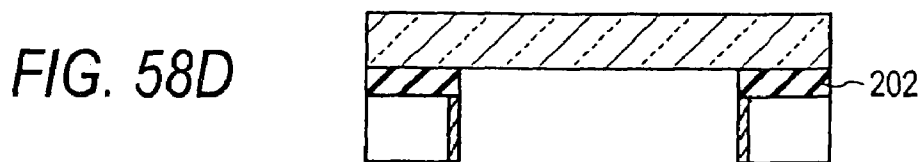
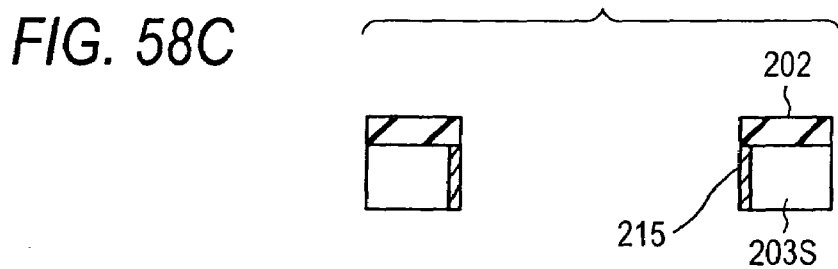
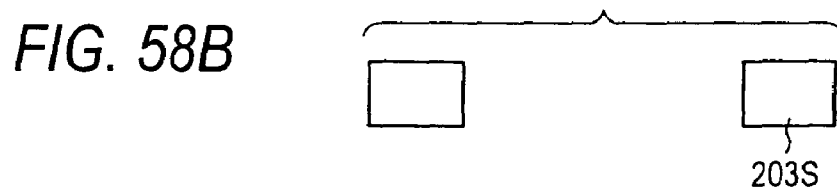
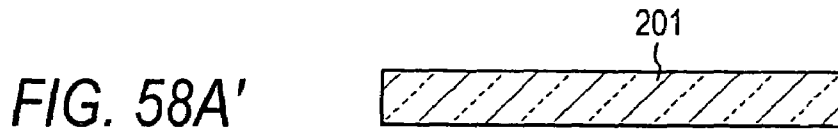

FIG. 59A



FIG. 59A'

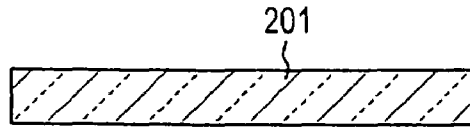

FIG. 59B

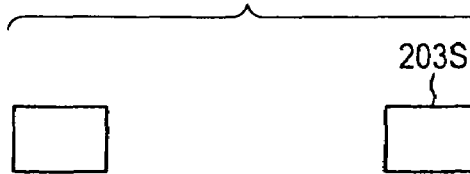

FIG. 59B'

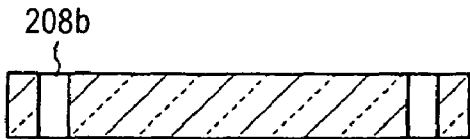

FIG. 59C

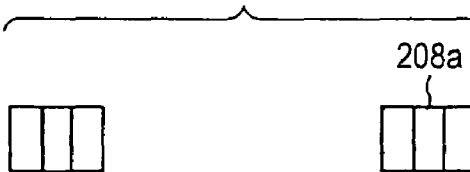

FIG. 59D

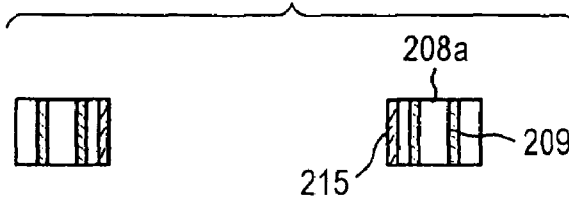

FIG. 59E

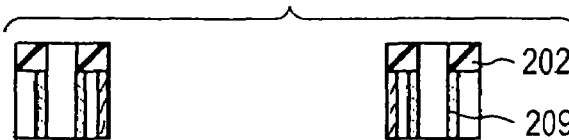

FIG. 59F

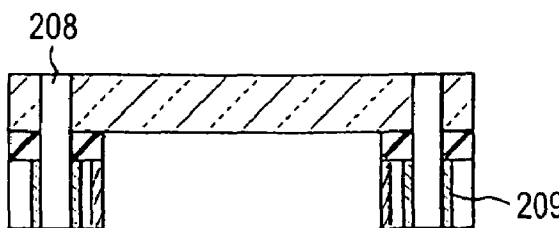

FIG. 60A

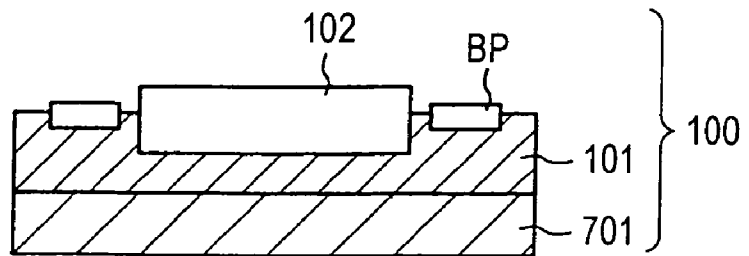

FIG. 60B

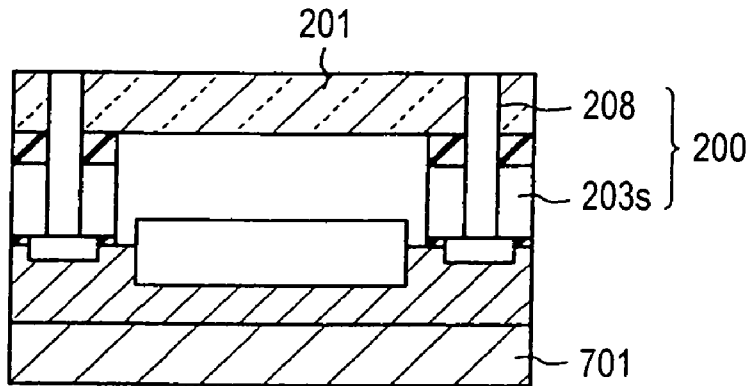

FIG. 60C

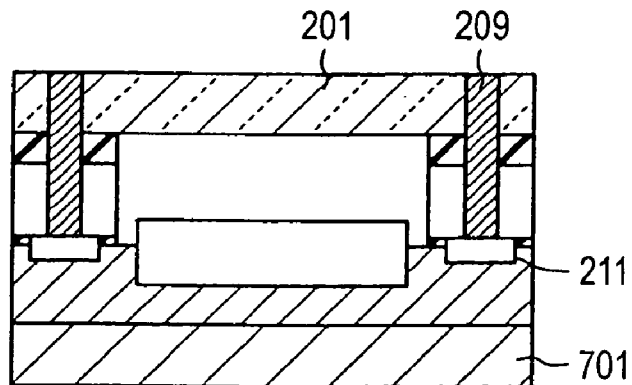

FIG. 60D

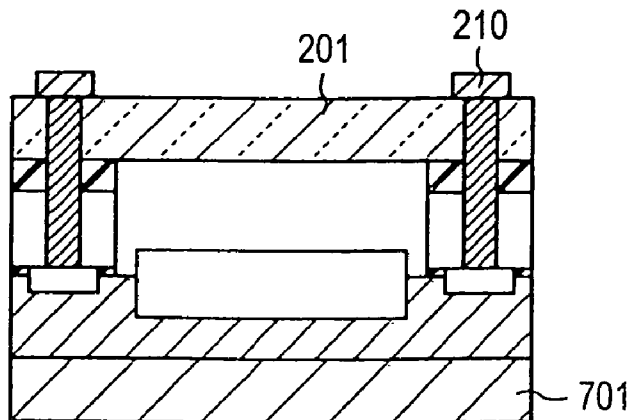

FIG. 61A

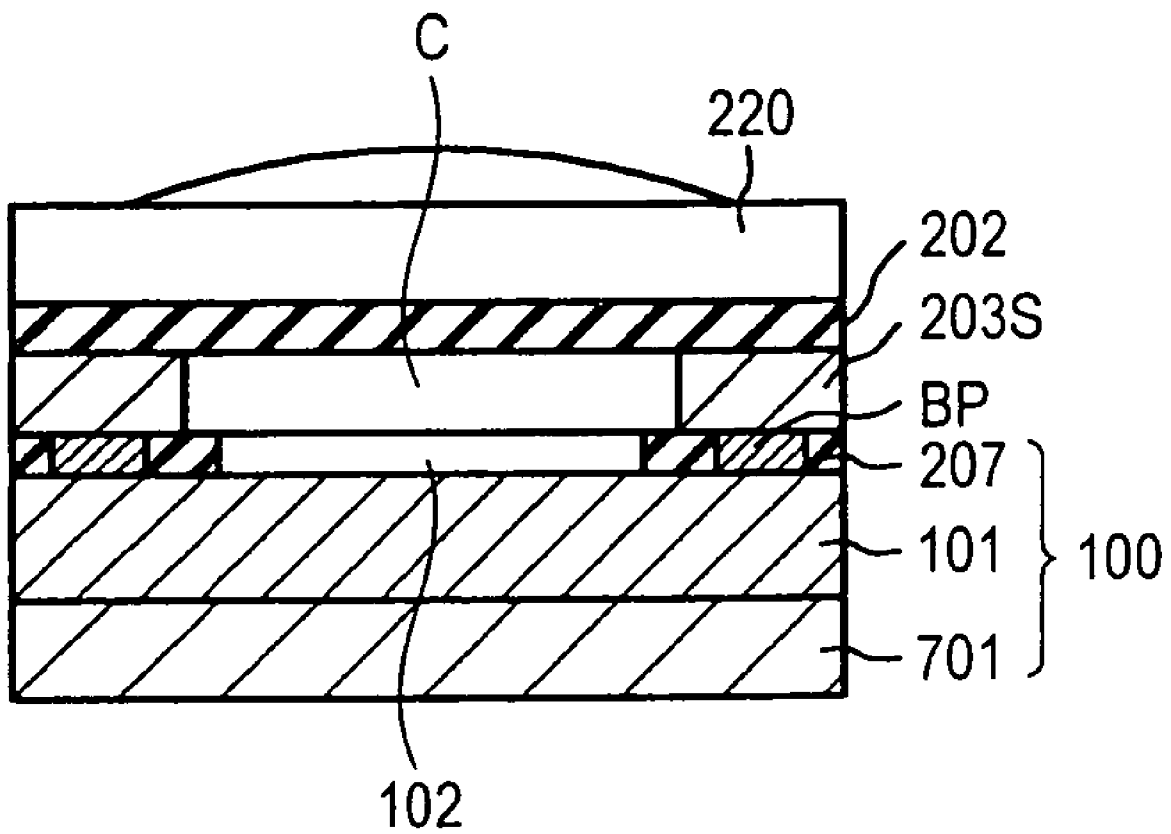

FIG. 61B

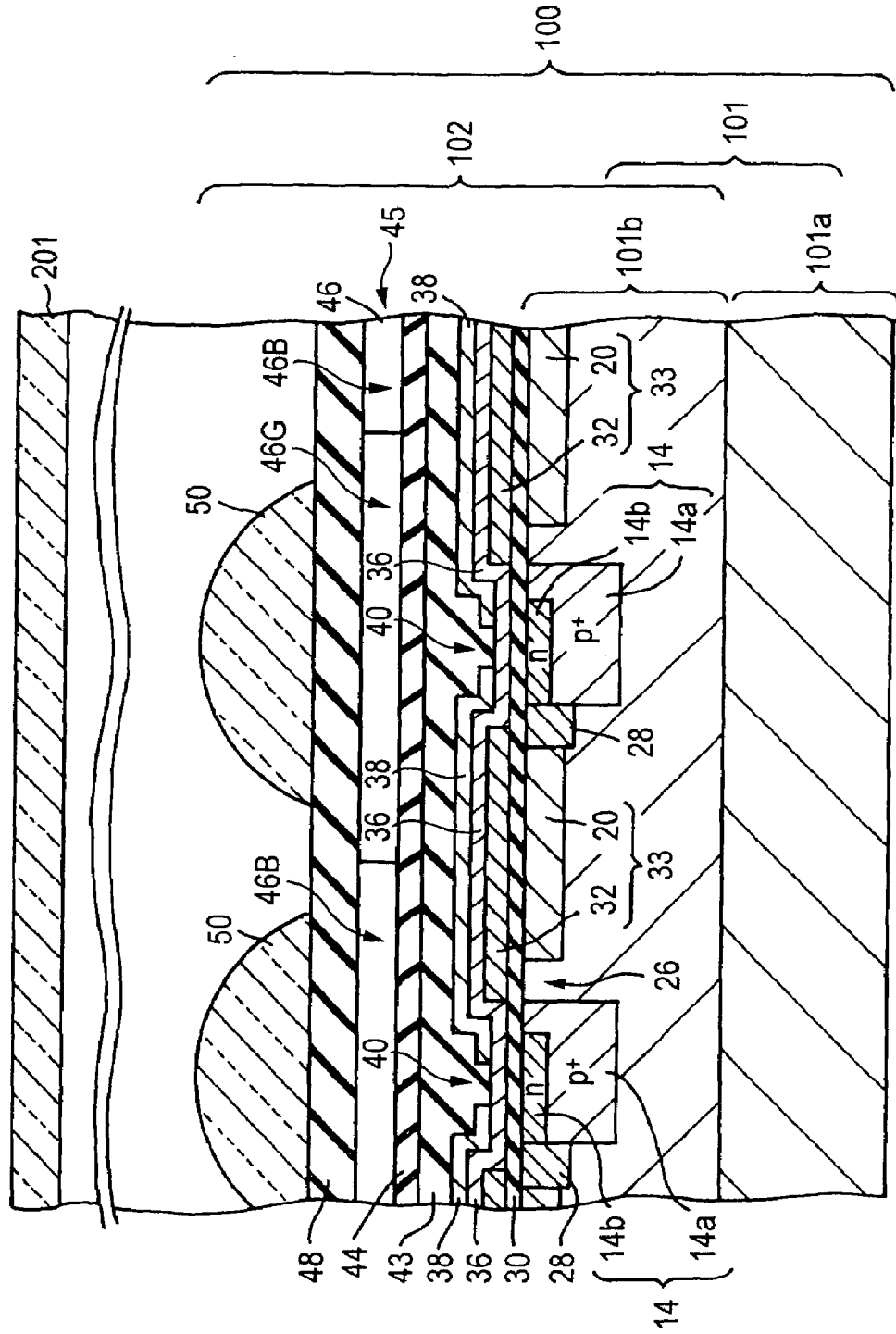

FIG. 62A

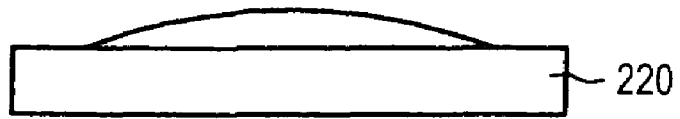

FIG. 62A'



FIG. 62B

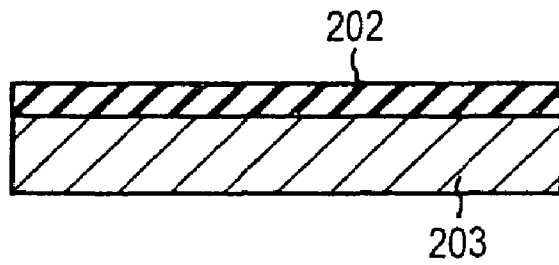

FIG. 62C

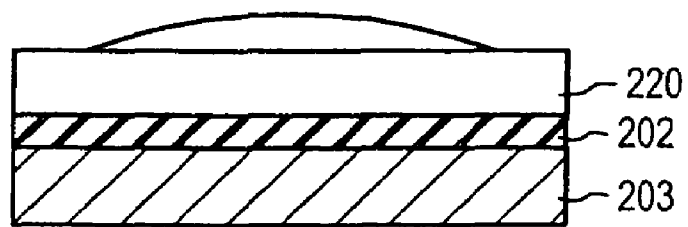

FIG. 62D

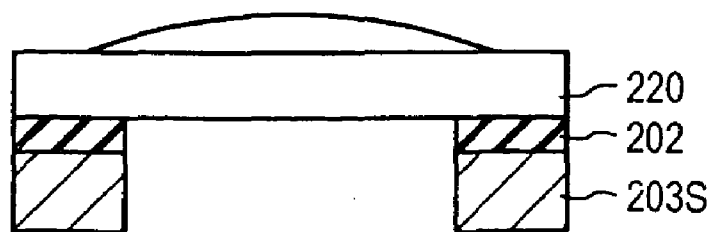

FIG. 63A

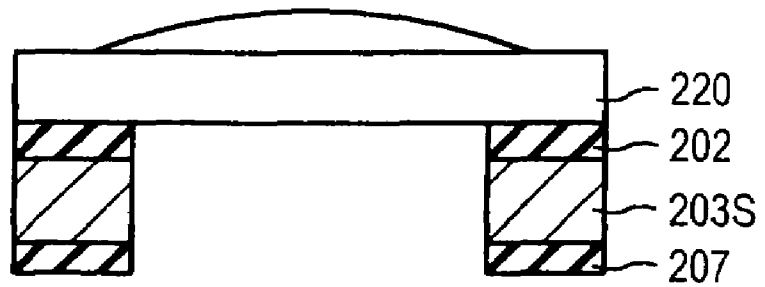

FIG. 63B

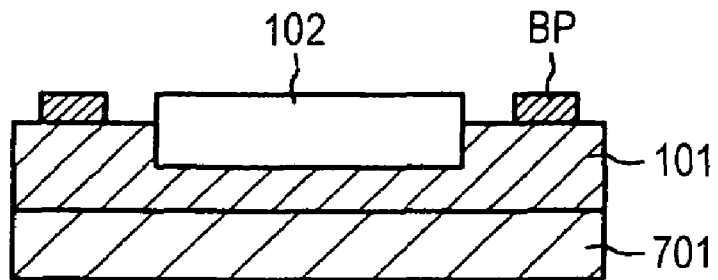

FIG. 63C

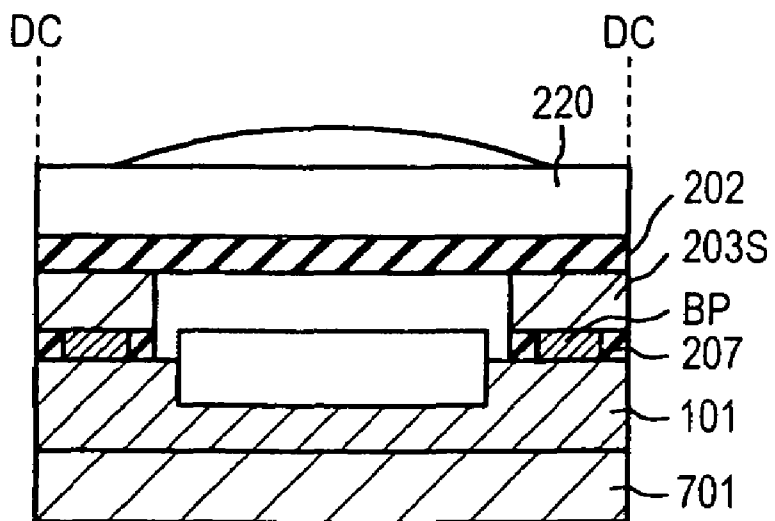

FIG. 64A

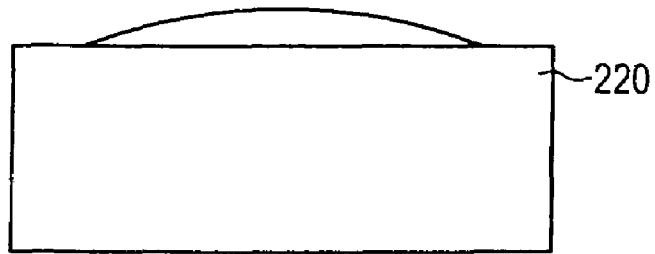

FIG. 64B

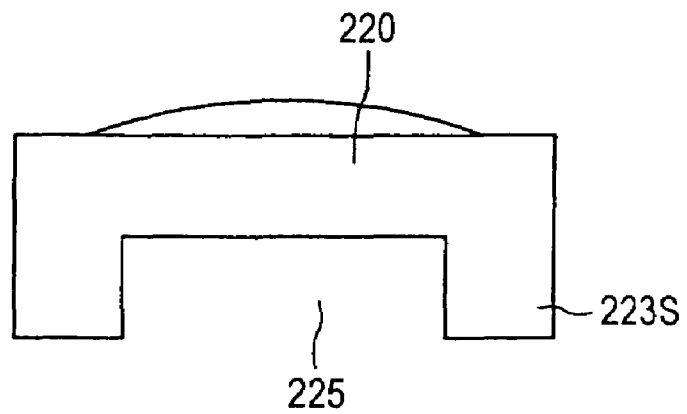

FIG. 65A

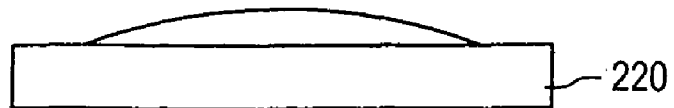

FIG. 65B

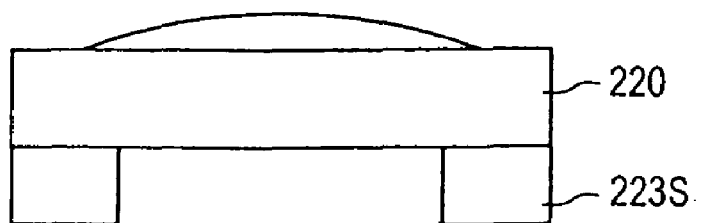

FIG. 66A

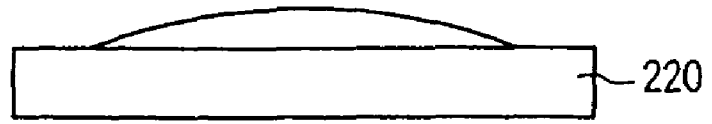

FIG. 66A'

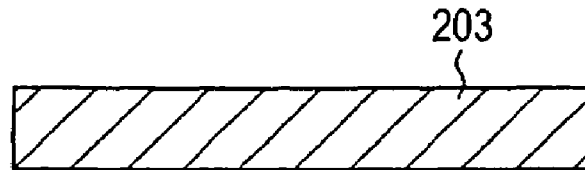

FIG. 66B

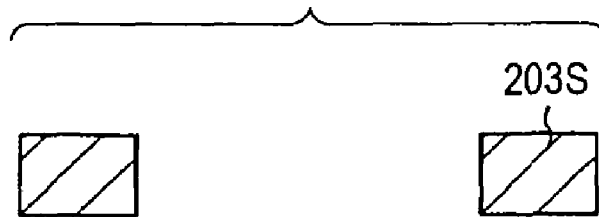

FIG. 66C

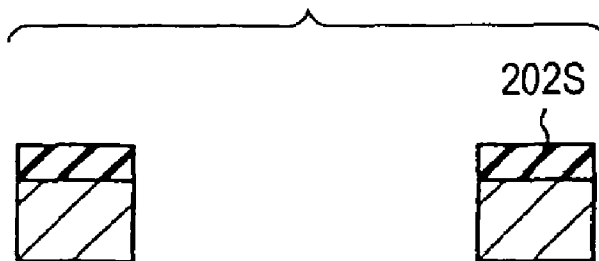

FIG. 66D

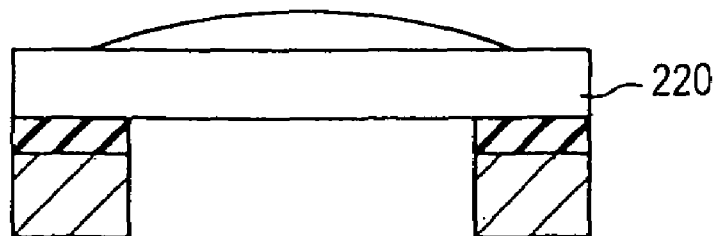

FIG. 67A

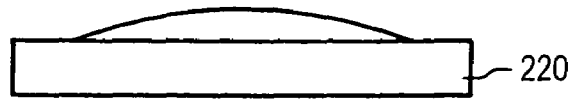

FIG. 67B

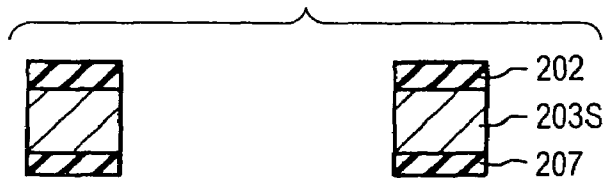

FIG. 67C

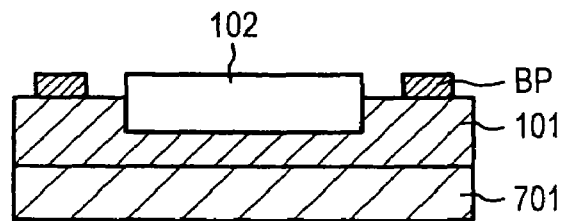

FIG. 67D

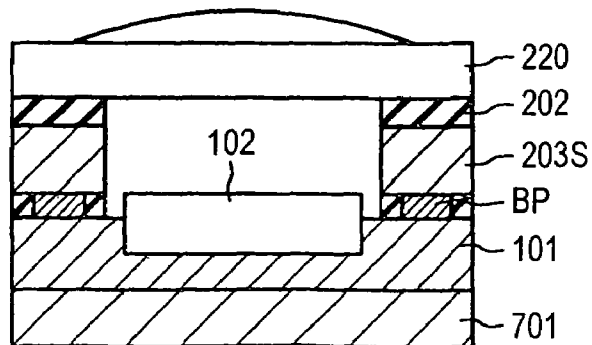

FIG. 68A

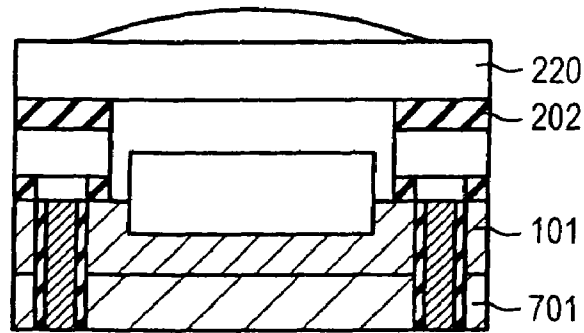

FIG. 68B

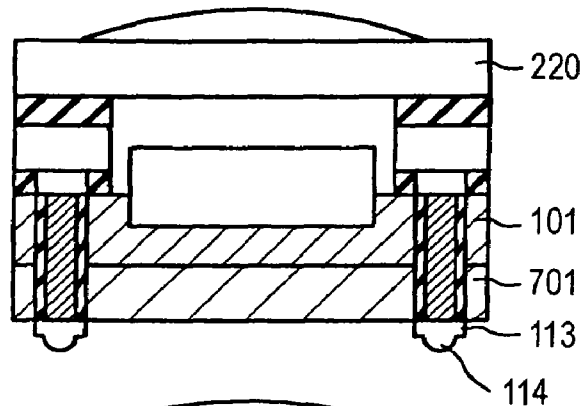

FIG. 68C

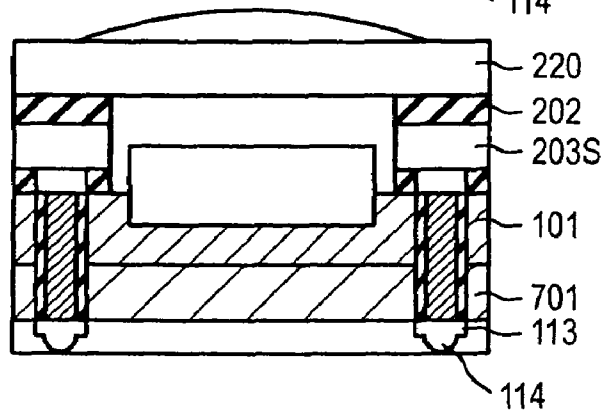

FIG. 68D

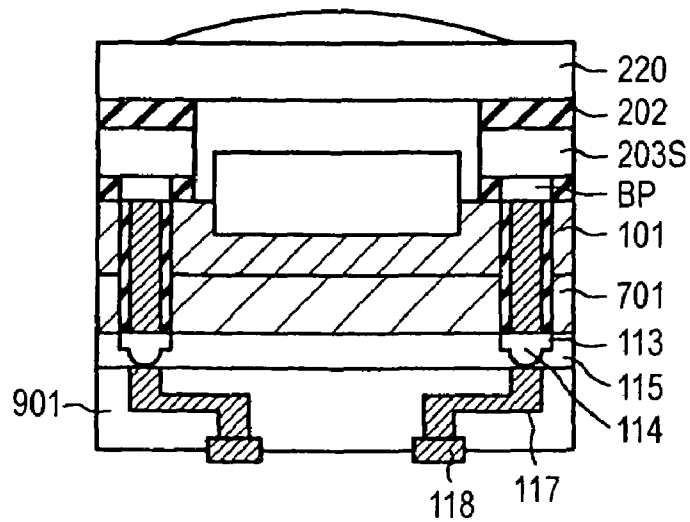

FIG. 71B

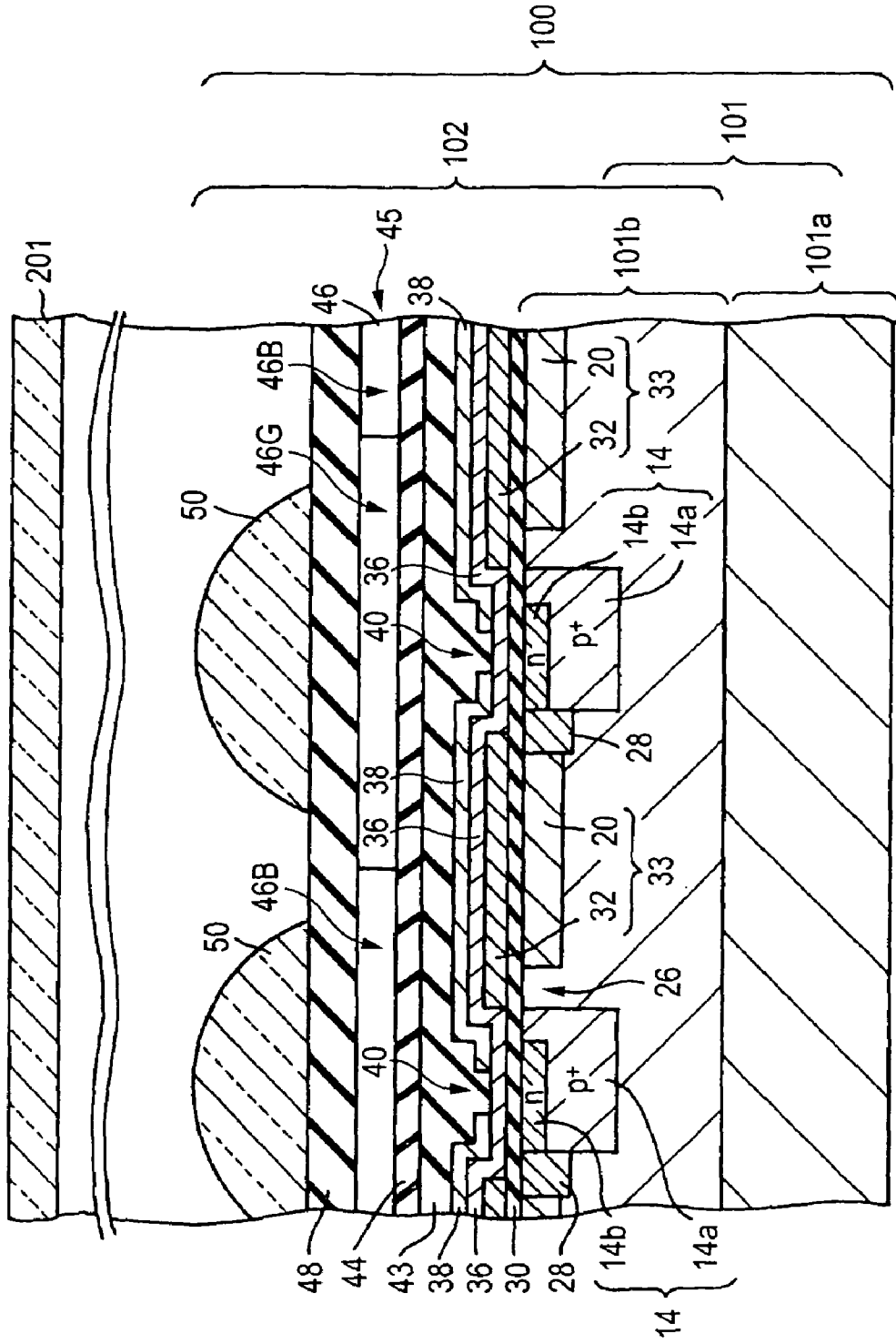

FIG. 72A

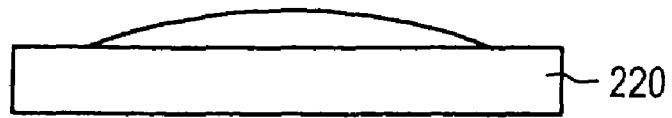

FIG. 72A'



FIG. 72B

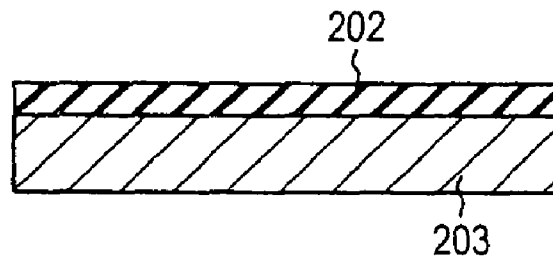

FIG. 72C

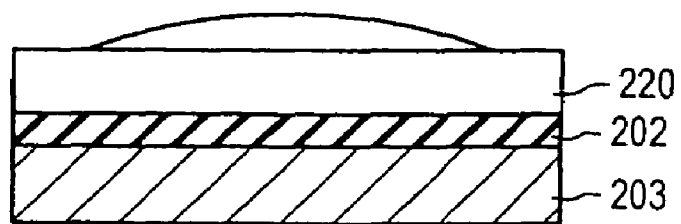

FIG. 72D

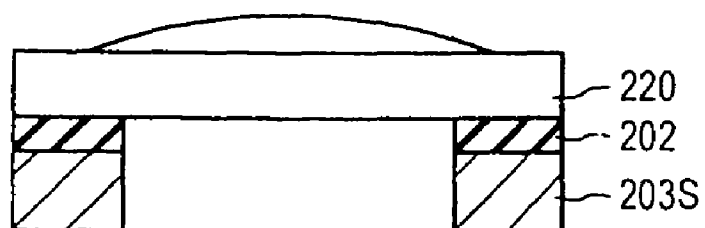

FIG. 73A

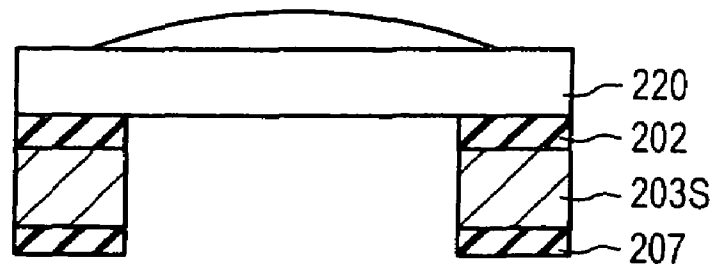

FIG. 73B

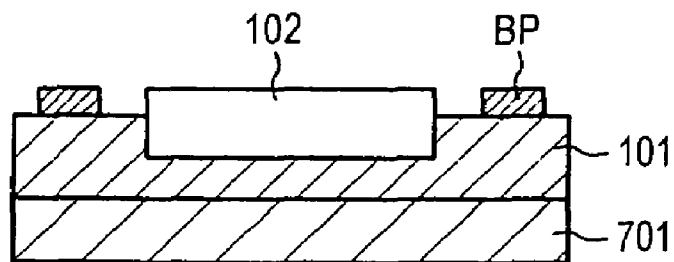

FIG. 73C

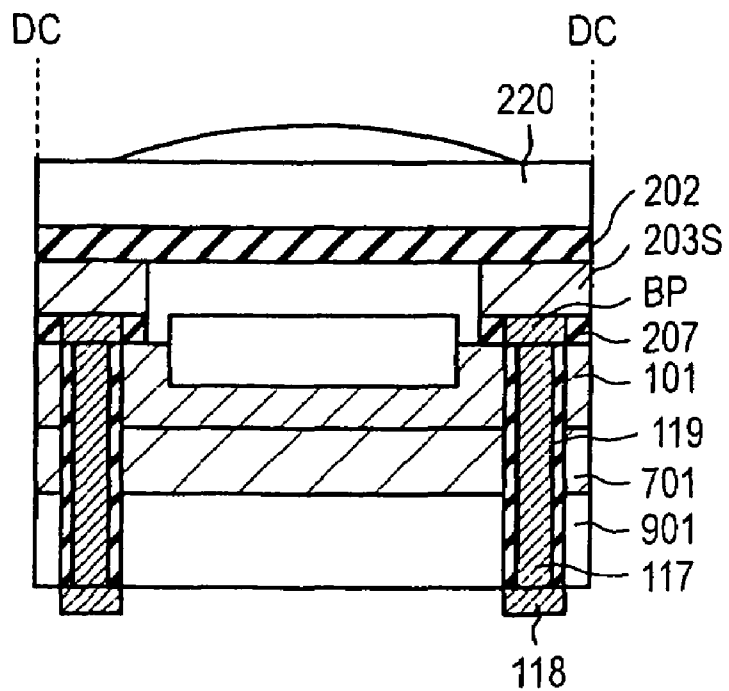

FIG. 74A

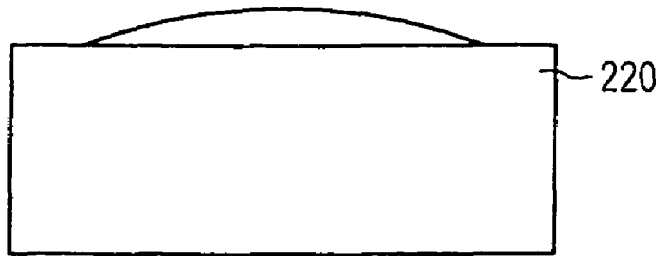

FIG. 74B

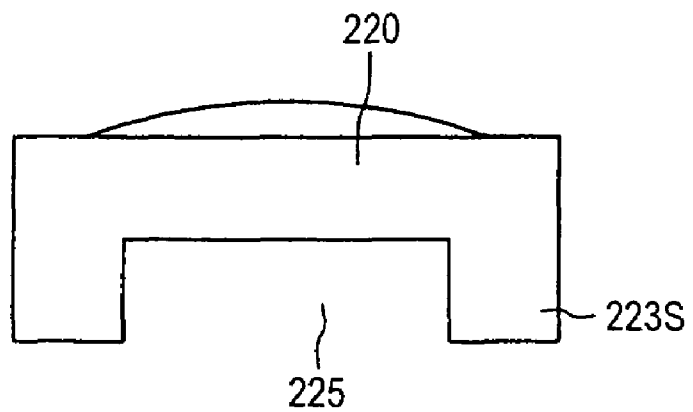

FIG. 75A

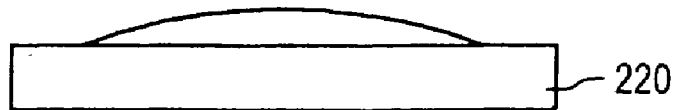

FIG. 75B

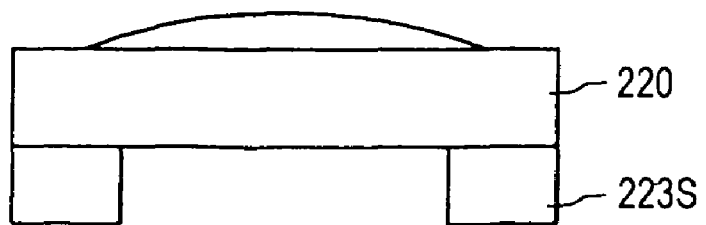

FIG. 76A

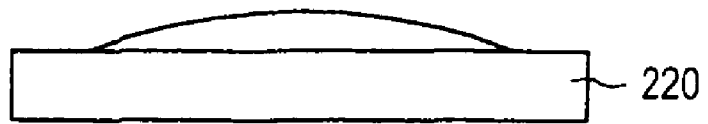

FIG. 76A'

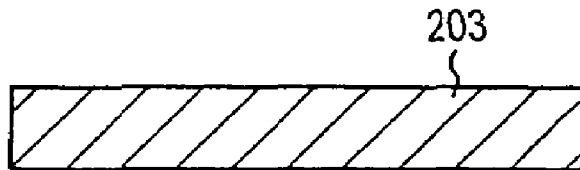

FIG. 76B



FIG. 76C

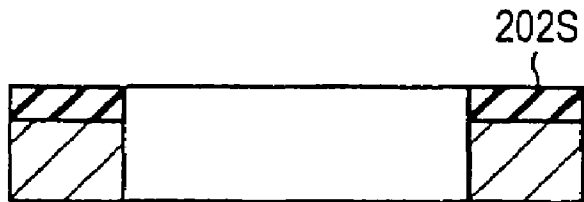

FIG. 76D

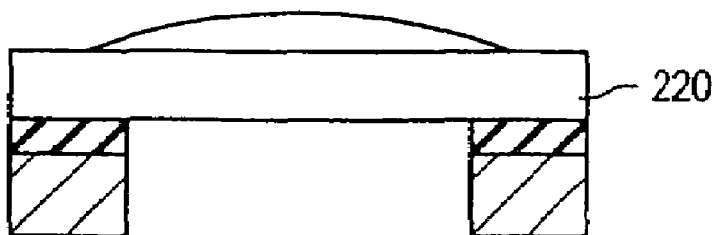

FIG. 77A

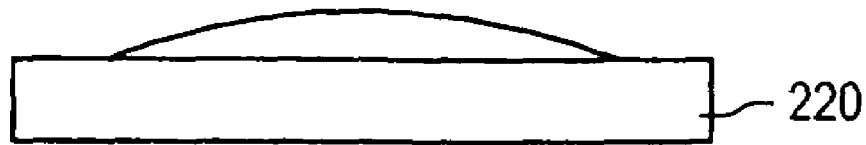

FIG. 77B

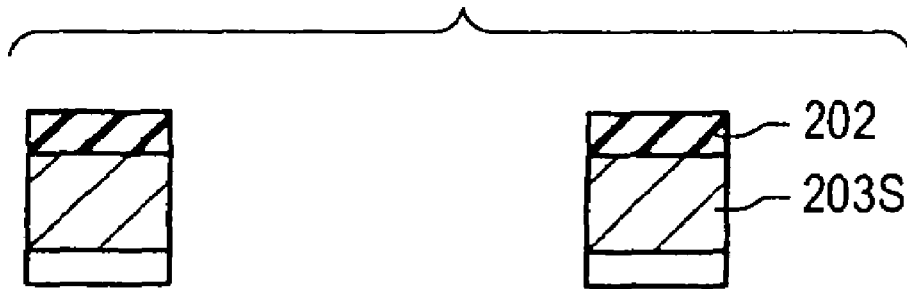

FIG. 77C

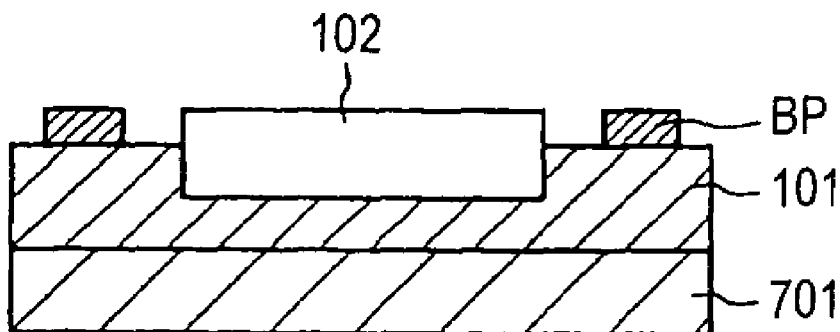

FIG. 78A

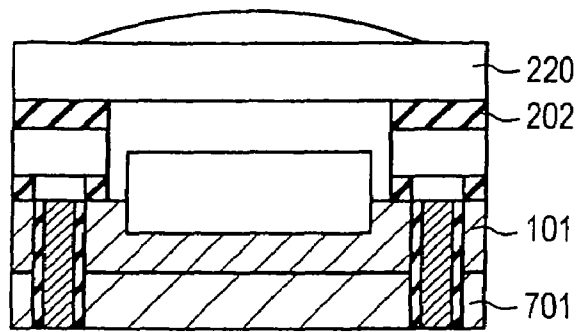

FIG. 78B

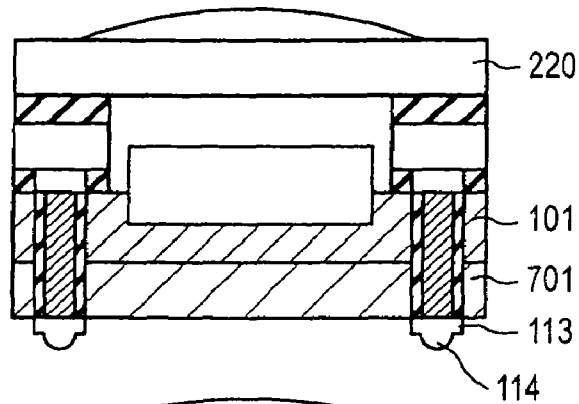

FIG. 78C

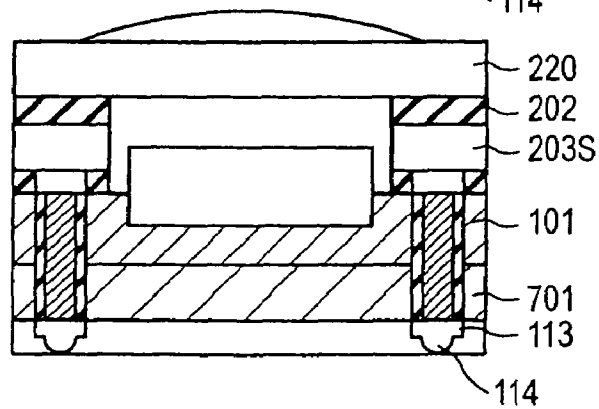

FIG. 78D

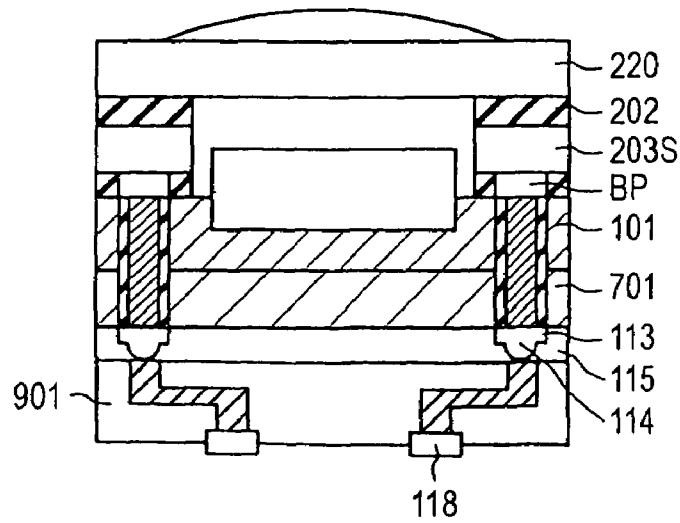

FIG. 79

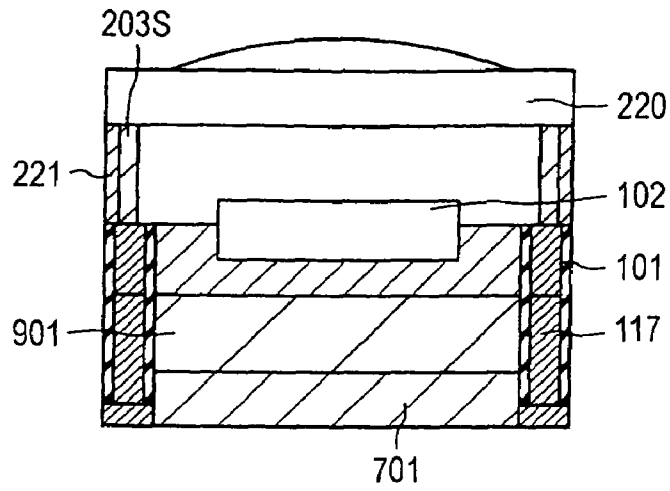

FIG. 80

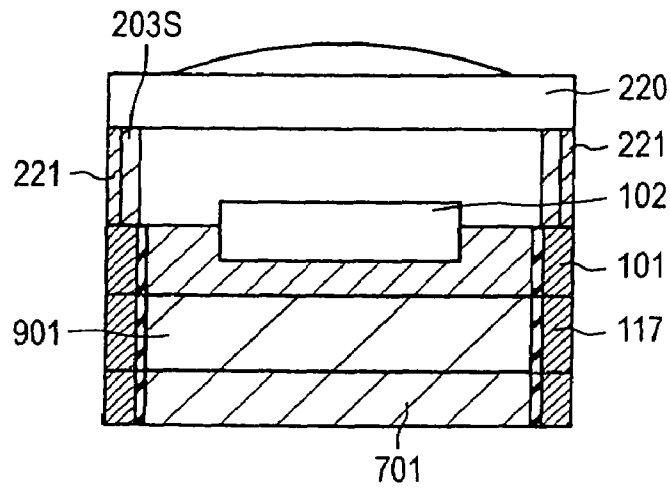

FIG. 81A

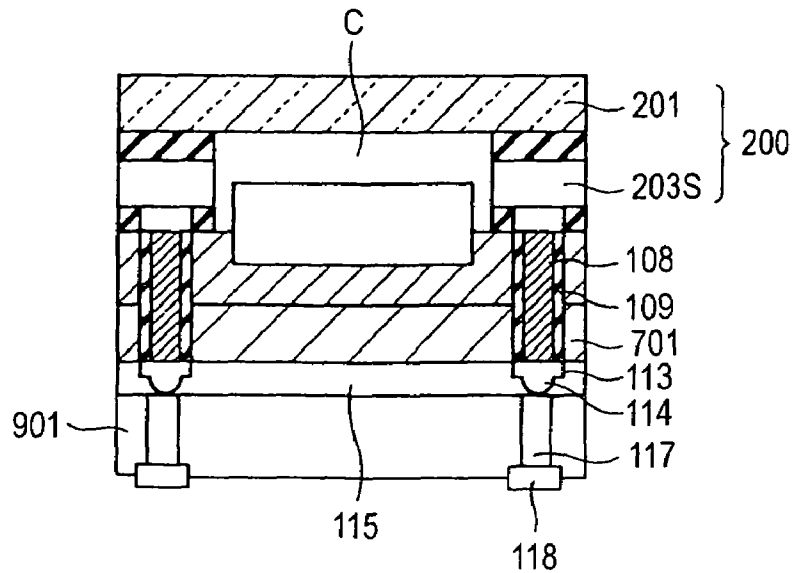

FIG. 82A

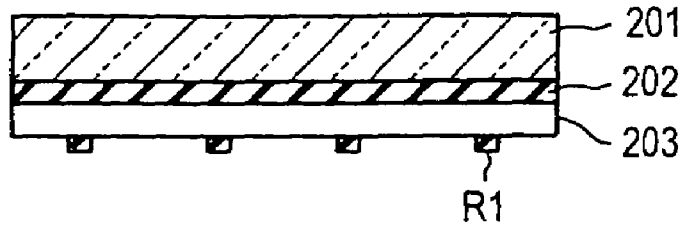

FIG. 82B

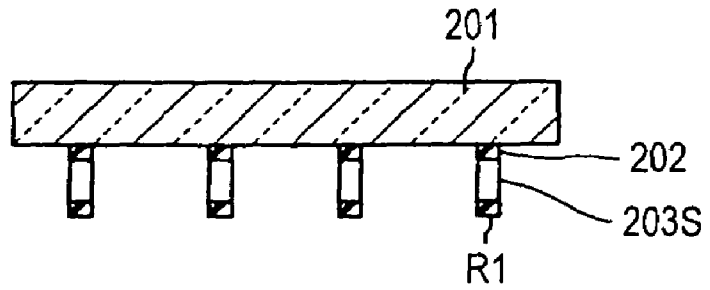

FIG. 82C

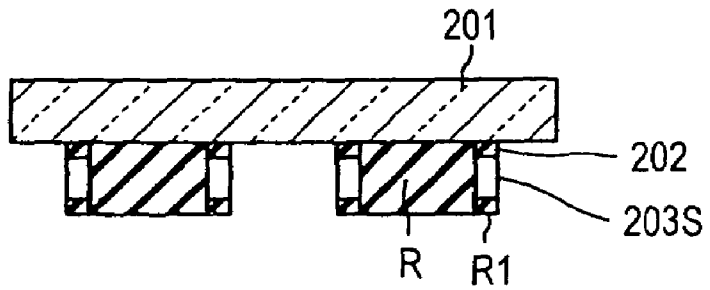

FIG. 82D

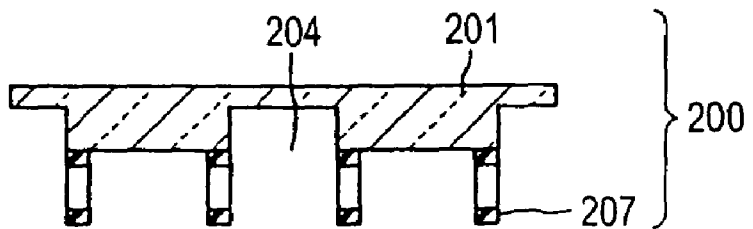

FIG. 83A

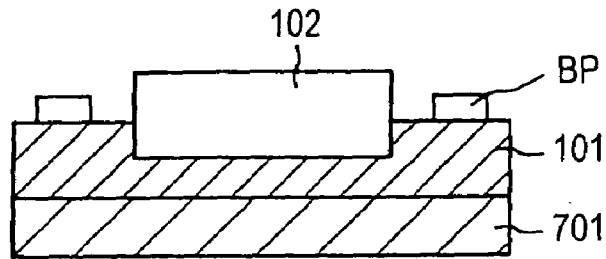

FIG. 83B

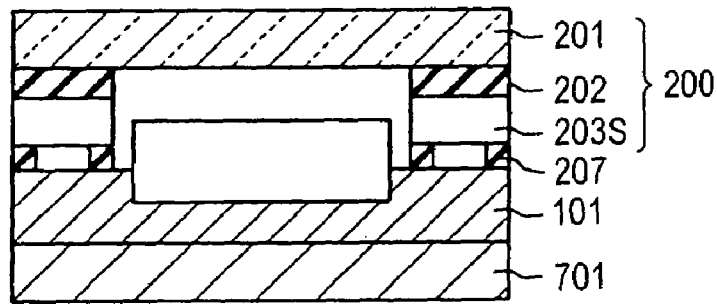

FIG. 83C

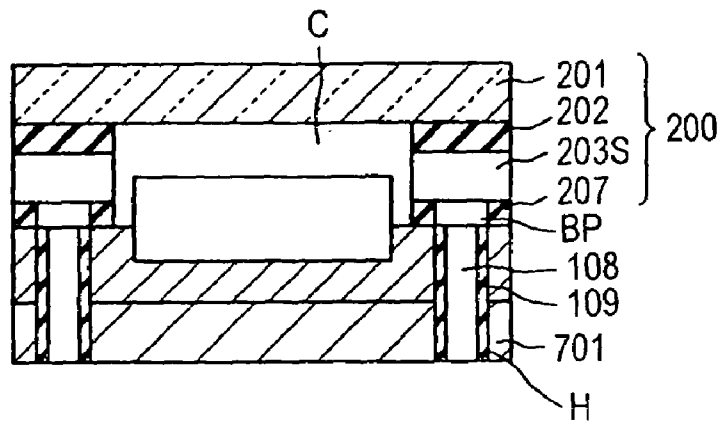

FIG. 84A

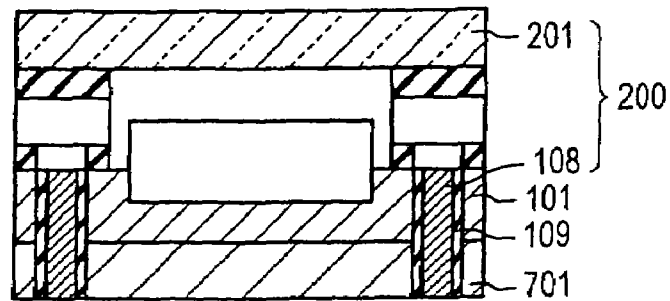

FIG. 84B

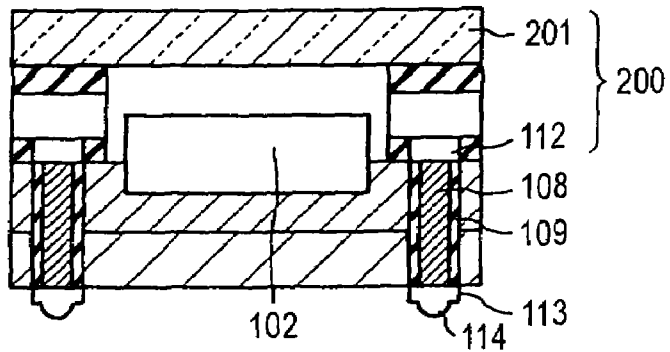

FIG. 84C

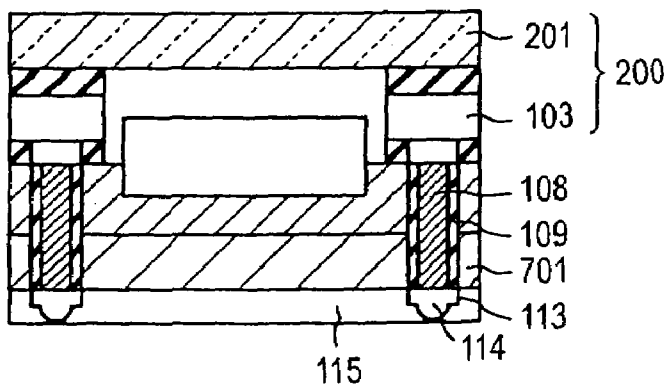

FIG. 84D

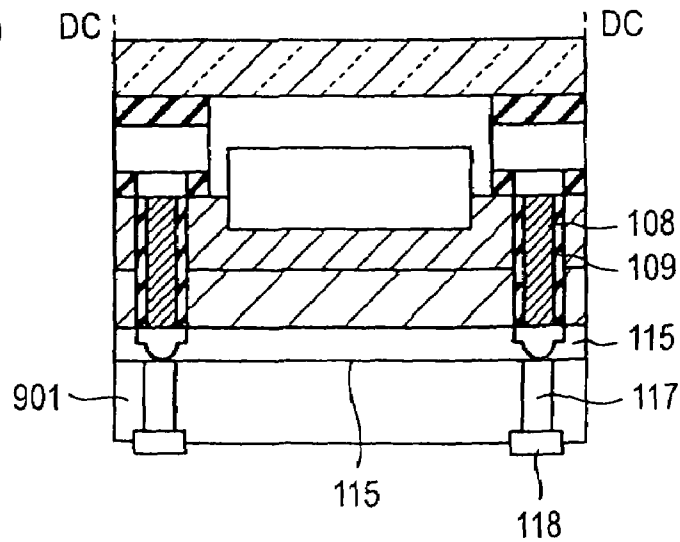

FIG. 85A

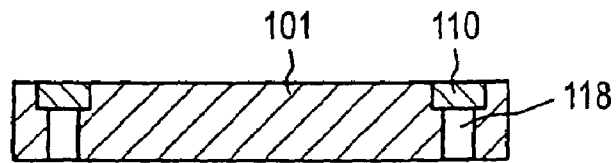

FIG. 85B

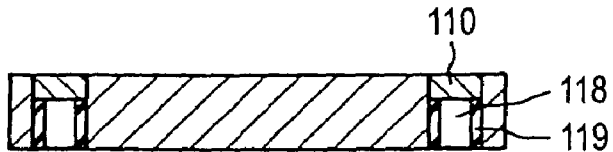

FIG. 85C

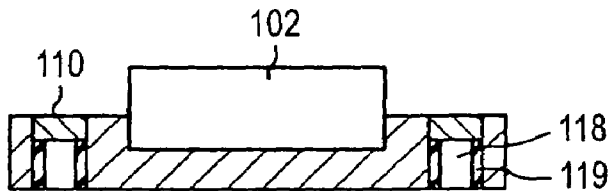

FIG. 85D

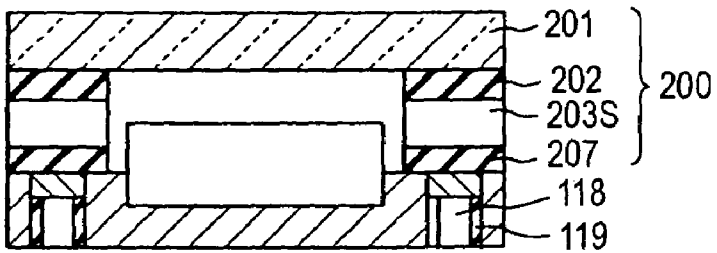

FIG. 85E

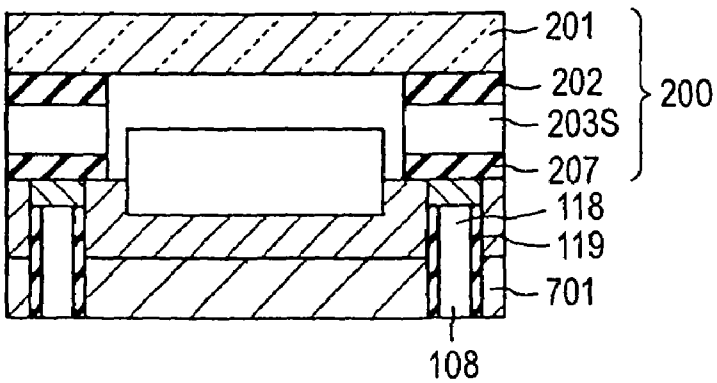

FIG. 86A

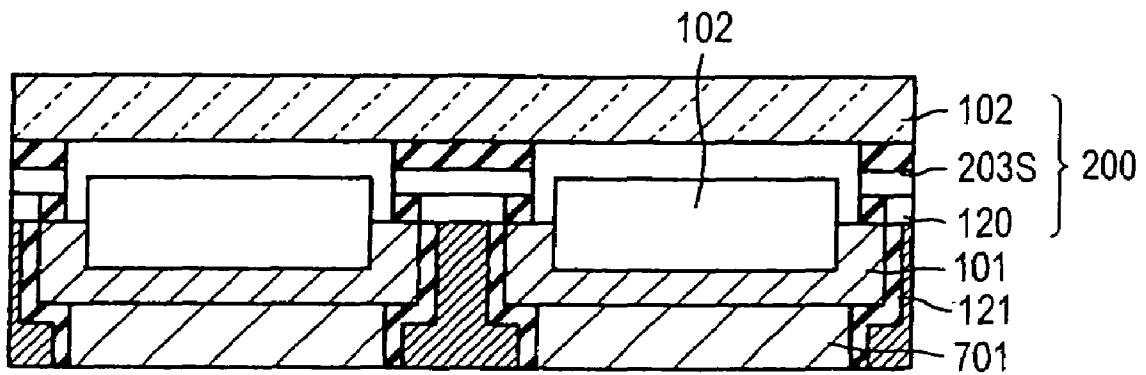

FIG. 86B

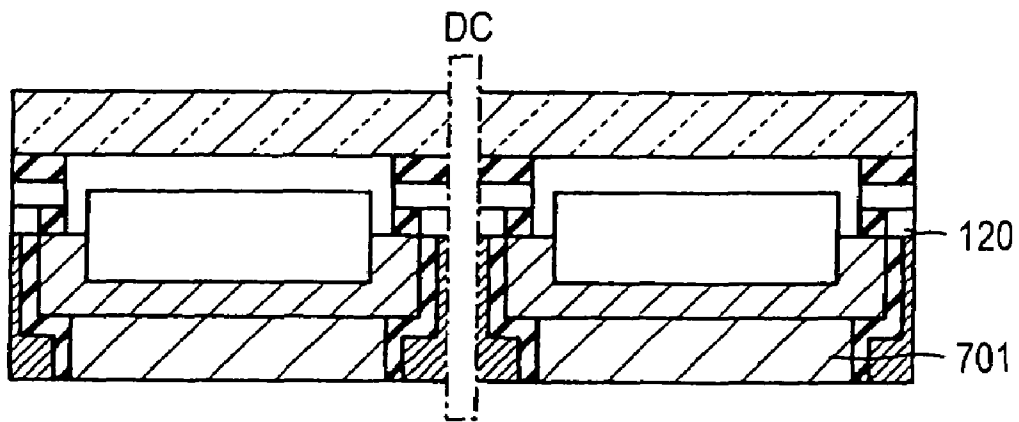

FIG. 87

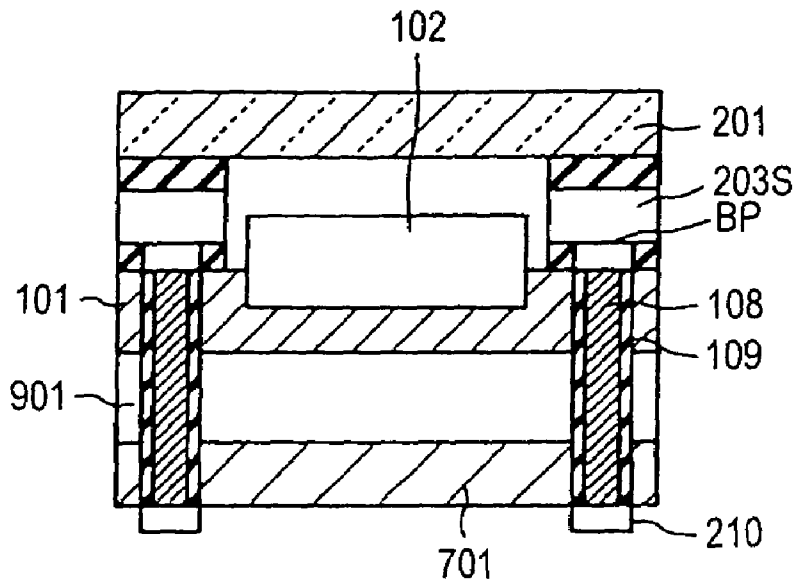
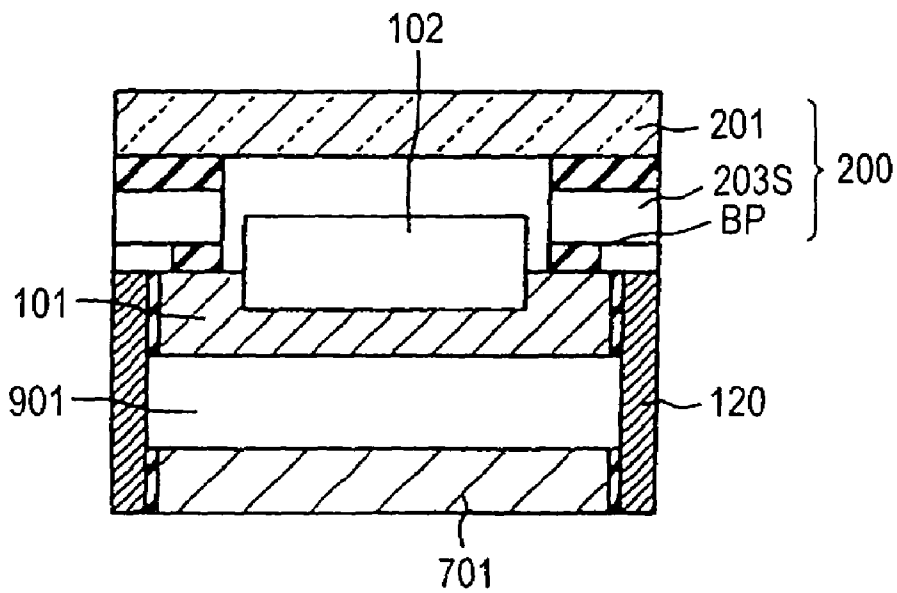

FIG. 88



**SOLID-STATE IMAGING DEVICE AND
METHOD OF MANUFACTURING SAID
SOLID-STATE IMAGING DEVICE**

This application is divisional of application Ser. No. 10/617,707 filed on Jul. 14, 2003 now U.S. No. Pat. 7,074,638, which is a continuation-in-part of abandoned application Ser. No. 10/419,861 filed on Apr. 22, 2003 now abandoned, for which priority is claimed under 35 U.S.C. § 120. This application also claims priority under 35 U.S.C. § 119 to Japanese Applications 119262 filed on Apr. 22, 2002, 154528 filed on May 28, 2002, 183072 filed on Jun. 24, 2002, 219645 filed on Jul. 29, 2002 and 219791 filed on Jul. 29, 2002, the entire contents of which are hereby incorporated by reference.

BACKGROUND OF THE INVENTION

1. Field of the Invention

The present invention relates to a solid-state imaging device and a method of manufacturing the solid-state imaging device. More particularly, the invention relates to a solid-state imaging device of a chip size package (CSP) type in which a microlens is integrally provided on a chip.

2. Description of the Related Art

A reduction in the size of a solid-state image pickup device, such as a CCD (Charge Coupled Device), has been required because of the necessity of application to a mobile telephone or a digital camera.

As an example, there has been proposed a solid-state imaging device in which a microlens is provided in the light receiving area of a semiconductor chip. In particular, for example, there has been proposed a solid-state imaging device which is provided with a microlens in a light receiving region and is integrally mounted to have an airtight sealing portion between the light receiving region and the microlens, thereby reducing the size of the solid-state imaging device (JP-A-7-202152 gazette).

According to such a structure, a mounting area can be reduced, and furthermore, an optical component such as a filter, a lens or a prism can be stuck to the surface of the airtight sealing portion and a mounting size can be reduced without a deterioration in the condensing capability of the microlens.

In the mounting of the solid-state imaging device, however, it is necessary to mount the solid-state imaging device on a support substrate for mounting in the fetch of a signal to the outside, thereby carrying out an electrical connection by a method such as bonding and performing sealing. Thus, there is a problem in that a great deal of time is required for the mounting because of a large man-hour.

In the mounting of the solid-state imaging device, however, it is necessary to provide the solid-state imaging device on a support substrate for mounting in the fetch of a signal to the outside, thereby carrying out an electrical connection by a method such as bonding and performing sealing. In addition, it is necessary to mount an optical component such as a filter, a lens or a prism and a signal processing circuit. Thus, there is a problem in that a great deal of time is required for the mounting because a large number of components are provided. Moreover, there has been a serious problem in that

various peripheral circuits are necessary with a requirement for an enhancement in a resolution, resulting in an increase in the size of the whole device.

SUMMARY OF THE INVENTION

In consideration of the actual circumstances, it is an object of the invention to provide a method of manufacturing a solid-state imaging device which can easily be manufactured and has a high reliability.

Moreover, it is another object to provide a solid-state imaging device which can easily be connected to a body.

In consideration of the actual circumstances, it is an object of the invention to provide a method of manufacturing a solid-state imaging device which can easily be manufactured and has a high reliability.

Moreover, it is another object to provide a solid-state imaging device having a small size and a high driving speed.

Therefore, the invention provides a method of manufacturing a solid-state imaging device comprising the steps of forming a plurality of IT-CCDs on a surface of a semiconductor substrate, bonding a translucent member to the surface of the semiconductor substrate in order to have a gap opposite to each light receiving region of the IT-CCD, forming an external connecting terminal corresponding to the IT-CCD, and isolating a bonded member obtained at the bonding step and provided with the external connecting terminal for each of the IT-CCDs.

According to such a structure, positioning is carried out on a wafer level, and collective mounting and integration are sequentially performed for isolation every IT-CCD. Consequently, it is possible to form a solid-state imaging device which can easily be manufactured and has a high reliability.

Moreover, it is desirable that the step of bonding a translucent member should include the steps of preparing a translucent substrate having a concave portion corresponding to a region in which the IT-CCD is to be formed, and bonding the translucent substrate to the surface of the semiconductor substrate.

According to such a structure, the concave portion is only formed on the translucent substrate. Consequently, the concave portion can be formed to easily have a gap opposite to each light receiving region. Therefore, the number of components can be decreased and the manufacture can easily be carried out.

It is desirable that the method should further comprise, prior to the bonding step, the step of selectively removing the surface of the semiconductor substrate to surround the light receiving region, thereby forming a protruded portion, a gap being formed between the light receiving region and the translucent member by the protruded portion.

According to such a structure, the mounting is only carried out by interposing the protruded portion (spacer) which is previously formed on the surface of the semiconductor substrate. Consequently, it is possible to easily provide a solid-state imaging device having an excellent workability and a high reliability.

Moreover, the method is characterized in that, at the bonding step, a gap is formed between the semiconductor substrate and the translucent member through a spacer provided to surround the light receiving region.

According to such a structure, it is possible to easily provide a solid-state imaging device having a high reliability by only interposing the spacer.

Furthermore, the method is characterized in that the isolating step includes the step of separating the translucent member to position a peripheral edge portion of the translucent

member onto an inside of a peripheral edge portion of the IT-CCD in such a manner that a surface of a peripheral edge portion of the IT-CCD is exposed from the translucent member.

According to such a structure, it is possible to easily fetch an electrode from the surface of the semiconductor substrate which is exposed.

Preferably, the method is characterized in that the bonding step is performed at a temperature under 80 degree C.

According to such a structure, it is possible to reduce generation of distortion after bonding, if each of members has a different coefficient of linear thermal expansion.

Preferably, the method is characterized in that, in the bonding step, a room temperature setting adhesive is utilized for bonding.

According to the method, it is possible to bond the translucent member and the semiconductor substrate without raising temperature, and to prevent a generation of distortion.

Instead of the room temperature setting adhesive, the method is also characterized in that, in the bonding step, a photo-curing adhesive is utilized for bonding the translucent member and the semiconductor substrate.

According to the method, it is also possible to bond the translucent member and the semiconductor substrate without raising a temperature, and to preventing a generation of distortion.

Furthermore, in the bonding step, it may be used a semi-curing adhesive for bonding the translucent member and the semiconductor substrate. Thereby, it is possible to realize a sophisticated positioning.

Preferably, the method is characterized in that, prior to the isolating step, the method includes a step of resin shielding for shielding the translucent member in a vicinity of bonding link with the semiconductor substrate by resin.

According to the method, it possible to prevent water from permeating and form a reliable IT-CCD.

Also, it is preferable to perform the resin shielding step at a temperature under 80 degree C.

According to the method, it is possible to bond the translucent member and the semiconductor substrate without raising temperature, and to reduce a generation of distortion.

Moreover, the invention provides a solid-state imaging device comprising a semiconductor substrate provided with an IT-CCD, and a translucent member connected to the semiconductor substrate in order to have a gap opposite to a light receiving region of the IT-CCD, wherein a connecting terminal is provided on a surface of the translucent member which is opposed to an attached surface of the semiconductor substrate, and the connecting terminal is connected to the semiconductor substrate via a through hole provided in the translucent member.

According to such a structure, signal fetch or conduction can be carried out over the translucent member. Consequently, attachment can easily be carried out, an assembly into the device can readily be performed, and the size of the whole device can be reduced. Moreover, the translucent member is connected to the semiconductor substrate in order to have a gap opposite to the light receiving region of the IT-CCD. Thus, it is possible to provide a solid-state imaging device having a small size and an excellent condensing property.

It is desirable that the translucent member should be connected to the semiconductor substrate with a spacer. Consequently, precision in the dimension of the gap can be enhanced and it is possible to obtain a solid-state imaging device which has an excellent optical characteristic at a low cost.

It is desirable that the spacer should be constituted by the same material as that of the translucent member. Consequently, a strain can be prevented from being caused by a difference in a coefficient of thermal expansion for a change in a temperature together with the translucent member and a lifetime can be prolonged.

It is desirable that the spacer should be constituted by the same material as that of the semiconductor substrate. Consequently, a strain can be prevented from being caused by a difference in a coefficient of thermal expansion for a change in a temperature together with the semiconductor substrate and a lifetime can be prolonged.

It is desirable that the spacer should be constituted by a resin material. The resin material may be filled between the IT-CCD substrate and the translucent substrate or may be constituted by a sheet-shaped resin material. If the spacer is formed by filling the resin material between the translucent member and the semiconductor substrate, a stress is absorbed by an elasticity, and a strain can be prevented from being caused by a difference in a coefficient of thermal expansion for a change in a temperature and a lifetime can be prolonged.

It is desirable that the spacer should be constituted by a 42-alloy or silicon. Consequently, a cost can be reduced, and furthermore, a strain can be prevented from being caused by a difference in a coefficient of thermal expansion for a change in a temperature together with the semiconductor substrate and a lifetime can be prolonged. The 42-alloy is not restricted but another metal, ceramics or an inorganic material may be used.

The invention provides a method of manufacturing an IT-CCD, comprising the steps of forming a plurality of IT-CCDs on a surface of a semiconductor substrate, bonding a translucent member having a through hole filled with a conductive material on the surface of the semiconductor substrate in order to have a gap opposite to each light receiving region of the IT-CCD, and isolating a bonded member obtained at the bonding step every IT-CCD.

According to such a structure, positioning is carried out on a wafer level, and collective mounting and integration are sequentially performed for isolation every IT-CCD by using the translucent member having the through hole. Consequently, it is possible to form a solid-state imaging device which can easily be manufactured and has a high reliability.

It is desirable that the step of bonding a translucent member should include the steps of preparing a translucent substrate having a plurality of concave portions in positions corresponding to regions in which the IT-CCDs are to be formed and a through hole in the vicinity of the concave portions, and bonding the translucent substrate to the surface of the semiconductor substrate. Consequently, a manufacturing man-hour can be more reduced and the mounting can easily be carried out.

According to such a structure, the concave portion and the through hole are only formed in the translucent substrate. Consequently, the concave portion can easily be formed to have a gap opposite to each light receiving region and electrode fetch can also be performed readily. Therefore, the number of components can be decreased and the manufacture can easily be carried out.

It is desirable that the method should further comprise the step of forming a protruded portion on the surface of the semiconductor substrate to surround the light receiving region prior to the bonding step, a gap being formed between the light receiving region and the translucent member by the protruded portion. Consequently, it is possible to easily provide a solid-state imaging device having a high reliability by only the processing of the semiconductor substrate. If the

etching step of forming the protruded portion is carried out before the formation of the IT-CCD, the IT-CCD is less damaged and photolithography to be carried out over the surface of the substrate having a concavo-convex portion causes a pattern shift in some cases. On the other hand, if the etching step of forming the protruded portion is carried out after the formation of the IT-CCD, the IT-CCD is slightly damaged and an element region can be formed with high precision without hindering a manufacturing process for the IT-CCD.

It is desirable that at the bonding step, a gap should be formed between the semiconductor substrate and the translucent member through a space provided to surround the light receiving region.

According to such a structure, it is possible to easily provide a solid-state imaging device having a high reliability by only interposing the spacer.

Moreover, the invention provides a solid-state imaging device comprising a semiconductor substrate provided with an IT-CCD, and a translucent member connected to the semiconductor substrate in order to have a gap opposite to a light receiving region of the IT-CCD, wherein the translucent member constitutes an optical member having a condensing function.

According to such a structure, the optical member having a condensing function and/or an image forming function, for example, a lens is integrated. Consequently, the optical member does not need to be mounted, and a size can be reduced and a reliability can be enhanced. Moreover, attachment can easily be carried out and an assembly into the device can readily be performed. Thus, the size of the whole device can be reduced. Moreover, the translucent member is connected to the semiconductor substrate in order to have a gap opposite to the light receiving region of the IT-CCD. Thus, it is possible to provide a solid-state imaging device having a small size and an excellent condensing property.

It is desirable that the translucent member should be connected to the semiconductor substrate with a spacer. Consequently, precision in the dimension of the gap can be enhanced and it is possible to obtain a solid-state imaging device which has an excellent optical characteristic at a low cost.

It is desirable that the spacer should be constituted by the same material as that of the translucent member. Consequently, a strain can be prevented from being caused by a difference in a coefficient of thermal expansion for a change in a temperature together with the translucent member and a lifetime can be prolonged.

It is desirable that the spacer should be constituted by the same material as that of the semiconductor substrate. Consequently, a strain can be prevented from being caused by a difference in a coefficient of thermal expansion for a change in a temperature together with the semiconductor substrate and a lifetime can be prolonged.

It is desirable that the spacer should be constituted by a resin material. The resin material may be filled between the IT-CCD substrate and the translucent substrate or may be constituted by a sheet-shaped resin material. If the spacer is formed by filling the resin material between the translucent member and the semiconductor substrate, a stress is absorbed by an elasticity, and a strain can be prevented from being caused by a difference in a coefficient of thermal expansion for a change in a temperature and a lifetime can be prolonged.

It is desirable that the spacer should be constituted by a 42-alloy or silicon. Consequently, a cost can be reduced, and furthermore, a strain can be prevented from being caused by a difference in a coefficient of thermal expansion for a change in a temperature together with the semiconductor substrate

and a lifetime can be prolonged. The 42-alloy is not restricted but another metal, ceramics or an inorganic material may be used.

The invention provides a method of manufacturing a solid-state imaging device, comprising the steps of forming a plurality of IT-CCDs on a surface of a semiconductor substrate, bonding an optical member having a condensing function on the surface of the semiconductor substrate in order to have a gap opposite to each light receiving region of the IT-CCD, and isolating a bonded member obtained at the bonding step every IT-CCD.

According to such a structure, the IT-CCD substrate and the optical member having the condensing function are positioned on a wafer level, and collective mounting and integration are sequentially performed for isolation every IT-CCD. Consequently, it is possible to form a solid-state imaging device which can easily be manufactured and has a high reliability.

Moreover, it is desirable that at the step of bonding an optical member, a translucent substrate comprising a lens corresponding to the region in which the IT-CCD is to be formed and having a concave portion should be prepared and the translucent substrate should be bonded to the surface of the semiconductor substrate.

According to such a structure, the optical member such as a lens and the concave portion are only formed in the translucent substrate. Consequently, the concave portion can easily be formed to have a gap opposite to each light receiving region. Therefore, the number of components can be decreased and the manufacture can easily be carried out.

It is desirable that the method should further comprise the step of forming a protruded portion by selectively removing the surface of the semiconductor substrate to surround the light receiving region prior to the bonding step, a gap being formed between the light receiving region and the optical member by the protruded portion.

According to such a structure, the mounting is simply carried out by interposing the protruded portion (spacer) formed on the surface of the semiconductor substrate in advance. Consequently, it is possible to easily provide a solid-state imaging device having a high reliability with a high workability.

Moreover, the bonding step is characterized in that a gap is formed between the semiconductor substrate and the optical member through a spacer provided to surround the light receiving region.

According to such a structure, it is possible to easily provide a solid-state imaging device having a high reliability by only interposing the spacer.

Moreover, the isolating step is characterized by the step of cutting the optical member to position a peripheral edge portion of the optical member on an inside of a peripheral edge portion of the IT-CCD in such a manner that a surface of the peripheral edge portion of the IT-CCD is exposed from the optical member.

According to such a structure, it is possible to easily fetch an electrode over the surface of the semiconductor substrate thus exposed.

Next, the invention provides a solid-state imaging device comprising a first semiconductor substrate provided with an IT-CCD, and a translucent member having a condensing function which is connected to the first semiconductor substrate in order to have a gap opposite to a light receiving region of the IT-CCD, wherein a second semiconductor substrate constituting a peripheral circuit is provided on the first semiconductor substrate.

According to such a structure, the optical member having the condensing function, for example, a lens is integrated. Consequently, the optical member does not need to be mounted, and a size can be reduced and a reliability can be enhanced. Moreover, since a peripheral circuit board is also provided, attachment can easily be carried out and an assembly into the device can readily be performed. Thus, the size of the whole device can be reduced. Moreover, the translucent member is connected to the first semiconductor substrate in order to have a gap opposite to the light receiving region of the IT-CCD. Thus, it is possible to provide a solid-state imaging device having a small size and an excellent condensing property.

It is desirable that the translucent member should be connected to the first semiconductor substrate with a spacer. Consequently, precision in the dimension of the gap can be enhanced and it is possible to obtain a solid-state imaging device which has an excellent optical characteristic.

It is desirable that the spacer should be constituted by the same material as that of the translucent member. Consequently, a strain can be prevented from being caused by a difference in a coefficient of thermal expansion for a change in a temperature together with the translucent member and a lifetime can be prolonged.

It is desirable that the spacer should be constituted by the same material as that of the first semiconductor substrate. Consequently, a strain can be prevented from being caused by a difference in a coefficient of thermal expansion for a change in a temperature together with the first semiconductor substrate and a lifetime can be prolonged.

It is desirable that the spacer should be formed by filling a resin material between the translucent member and the first semiconductor substrate. Consequently, a stress is absorbed by an elasticity, and a strain can be prevented from being caused by a difference in a coefficient of thermal expansion for a change in a temperature and a lifetime can be prolonged.

The invention provides a method of manufacturing a solid-state imaging device, comprising the steps of forming a plurality of IT-CCDs on a surface of a first semiconductor substrate, forming a peripheral circuit on a surface of a second semiconductor substrate, bonding an optical member having a condensing function on the first semiconductor substrate and the second semiconductor substrate in order to have a gap opposite to each light receiving region of the IT-CCD, and isolating a bonded member obtained at the bonding step every IT-CCD.

According to such a structure, the IT-CCD substrate and the optical member having the condensing function are positioned on a wafer level, and collective mounting and integration are sequentially performed for isolation every IT-CCD. Consequently, it is possible to form a solid-state imaging device which can easily be manufactured and has a high reliability.

Moreover, it is desirable that at the step of bonding an optical member, a translucent substrate comprising a lens corresponding to the region in which the IT-CCD is to be formed and having a concave portion should be prepared and the translucent substrate should be bonded to the surface of the first semiconductor substrate.

According to such a structure, the optical member such as a lens and the concave portion are only formed in the translucent substrate. Consequently, the concave portion can easily be formed to have a gap opposite to each light receiving region. Therefore, the number of components can be decreased and the manufacture can easily be carried out.

It is desirable that the method should further comprise the step of forming a protruded portion by selectively removing

the surface of the first semiconductor substrate to surround the light receiving region prior to the bonding step, a gap being formed between the light receiving region and the optical member by the protruded portion.

According to such a structure, the mounting is simply carried out by interposing the protruded portion (spacer) formed on the surface of the first semiconductor substrate in advance. Consequently, it is possible to easily provide a solid-state imaging device having a high reliability with a high workability.

Moreover, the bonding step is characterized in that a gap is formed between the first semiconductor substrate and the optical member through a space provided to surround the light receiving region.

According to such a structure, it is possible to easily provide a solid-state imaging device having a high reliability by only interposing the spacer.

Moreover, the isolating step is characterized by the step of cutting the optical member to position a peripheral edge portion of the optical member on an inside of a peripheral edge portion of each of IT-CCDs of the first semiconductor substrate in such a manner that a surface of the peripheral edge portion of the each IT-CCD is exposed from the optical member.

According to such a structure, it is possible to easily fetch an electrode on the surface of the first semiconductor substrate thus exposed.

Therefore, the invention provides a solid-state imaging device comprising a first semiconductor substrate provided with an IT-CCD, and a translucent member connected to the first semiconductor substrate in order to have a gap opposite to a light receiving region of the IT-CCD, wherein a second semiconductor substrate having a peripheral circuit formed thereon is provided on a surface opposed to a surface of the first semiconductor substrate on which the IT-CCD is to be formed, and the peripheral circuit is connected to the IT-CCD via a through hole provided on the first semiconductor substrate.

According to such a structure, the peripheral circuit is provided and the first and second semiconductor substrates are electrically connected to each other via the through hole formed on the first semiconductor substrate. Consequently, the size of the whole device can be reduced, and furthermore, a distance between the first semiconductor substrate and the second semiconductor substrate can be reduced. Accordingly, a wiring resistance can be reduced and a driving speed can be increased.

Moreover, the first and second semiconductor substrates are bonded to each other directly through a method such as cold direct bonding. Consequently, it is possible to obtain firmer bonding. Furthermore, the electrical connection can be achieved well.

In addition, the first and second semiconductor substrates are bonded to each other with an adhesive layer in between. Consequently, desirable bonding can easily be carried out. It is desirable that the adhesive layer should have a coefficient of thermal expansion which is as close as possible to that of each of the first and second semiconductor substrates.

Furthermore, the first and second semiconductor substrates may be bonded to each other with a heat insulating material in between. Consequently, the heat of the second semiconductor substrate constituting the peripheral circuit is transferred to the IT-CCD substrate. Thus, it is possible to prevent the characteristic of the IT-CCD from being influenced adversely.

Moreover, the first and second semiconductor substrates are bonded to each other with a magnetic shield material in

between. Consequently, it is possible to block mutual noises made by unnecessary radiation.

Furthermore, the invention provides a method of manufacturing a solid-state imaging device, comprising the steps of forming a plurality of IT-CCDs on a surface of a first semiconductor substrate, forming a peripheral circuit on a surface of a second semiconductor substrate, bonding a translucent member on the surface of the first semiconductor substrate in order to have a gap opposite to each light receiving region of the IT-CCD, bonding the second semiconductor substrate to a back side of the first semiconductor substrate, forming a through hole on the first semiconductor substrate before or after the bonding step and the semiconductor substrate bonding step and electrically connecting the IT-CCD to a back face of the first semiconductor substrate, and isolating a bonded member obtained at the bonding step every IT-CCD.

According to such a structure, the first semiconductor substrate mounting the IT-CCD thereon and the second semiconductor substrate mounting the peripheral circuit thereon are positioned on a wafer level with respect to the translucent member, and are collectively mounted and integrated, and are thus isolated for each solid-state imaging device. Consequently, it is possible to form a solid-state imaging device which can easily be manufactured and has a high reliability.

It is desirable that at the semiconductor substrate bonding step, the first and second semiconductor substrates should be bonded to each other by direct bonding. Thus, it is possible to easily carry out the formation without making the substrate dirty due to the protrusion of an adhesive.

At the semiconductor substrate bonding step, moreover, the first and second semiconductor substrates may be bonded to each other with an adhesive layer in between, and they can easily be bonded to each other without a shift by a photocuring adhesive layer, a thermosetting adhesive layer or their combination.

BRIEF DESCRIPTION OF THE DRAWINGS

FIGS. 1A and 1B are a sectional view showing a solid-state imaging device formed by a method according to a first embodiment of the invention and an enlarged sectional view showing a main part,

FIGS. 2A to 2D are views showing a process for manufacturing the solid-state imaging device according to the first embodiment of the invention,

FIGS. 3A to 3C are views showing the process for manufacturing the solid-state imaging device according to the first embodiment of the invention,

FIGS. 4A to 4D are views showing a process for manufacturing a solid-state imaging device according to a second embodiment of the invention,

FIGS. 5A to 5E are views showing a process for manufacturing a solid-state imaging device according to a third embodiment of the invention,

FIGS. 6A to 6D are views showing a process for manufacturing a solid-state imaging device according to a fourth embodiment of the invention,

FIGS. 7A to 7D are views showing a process for manufacturing a solid-state imaging device according to a fifth embodiment of the invention,

FIGS. 8A to 8E are views showing a process for manufacturing a solid-state imaging device according to a sixth embodiment of the invention,

FIGS. 9A to 9E are views showing a process for manufacturing a solid-state imaging device according to a seventh embodiment of the invention,

FIGS. 10A to 10D are views showing a process for manufacturing a solid-state imaging device according to an eighth embodiment of the invention,

FIGS. 11A to 11D are views showing a process for manufacturing a solid-state imaging device according to a ninth embodiment of the invention,

FIGS. 12A and 12B are views showing a process for manufacturing a solid-state imaging device according to a tenth embodiment of the invention,

FIG. 13 is a view showing the process for manufacturing a solid-state imaging device according to the tenth embodiment of the invention,

FIGS. 14A and 14B are views showing a process for manufacturing a solid-state imaging device according to an eleventh embodiment of the invention,

FIGS. 15A to 15C are views showing a process for manufacturing a solid-state imaging device according to a twelfth embodiment of the invention,

FIGS. 16A to 16D are views showing a process for manufacturing a solid-state imaging device according to a thirteenth embodiment of the invention,

FIGS. 17A to 17C are views showing a process for manufacturing a solid-state imaging device according to a fourteenth embodiment of the invention,

FIG. 18 is a view showing a process for manufacturing a solid-state imaging device according to a fifteenth embodiment of the invention,

FIGS. 19A to 19D are views showing a process for manufacturing a solid-state imaging device according to a sixteenth embodiment of the invention,

FIGS. 20A to 20C are views showing a process for manufacturing a solid-state imaging device according to a seventeenth embodiment of the invention,

FIGS. 21A to 21F are views showing a process for manufacturing a solid-state imaging device according to an eighteenth embodiment of the invention,

FIGS. 22A to 22C are views showing a process for manufacturing a solid-state imaging device according to a nineteenth embodiment of the invention,

FIGS. 23A to 23D are views showing a process for manufacturing a solid-state imaging device according to a twentieth embodiment of the invention,

FIG. 24 is a view showing a process for manufacturing a solid-state imaging device according to a twenty-first embodiment of the invention,

FIGS. 25A to 25E are views showing the process for manufacturing a solid-state imaging device according to the twenty-first embodiment of the invention,

FIG. 26 is a view showing a process for manufacturing a solid-state imaging device according to a twenty-second embodiment of the invention,

FIGS. 27A to 27C are views showing a process for manufacturing a solid-state imaging device according to a twenty-third embodiment of the invention,

FIGS. 28A to 28D are views showing the process for manufacturing a solid-state imaging device according to the twenty-third embodiment of the invention,

FIGS. 29A to 29E are views showing a process for manufacturing a solid-state imaging device according to a twenty-fourth embodiment of the invention,

FIGS. 30A and 30B are views showing a process for manufacturing a solid-state imaging device according to a twenty-fifth embodiment of the invention,

FIG. 31 is a view showing a process for manufacturing a solid-state imaging device according to a twenty-sixth embodiment of the invention,

11

FIG. 32 is a view showing a process for manufacturing a solid-state imaging device according to a twenty-seventh embodiment of the invention,

FIG. 33 is a view showing a solid-state imaging device according to a twenty-eighth embodiment of the invention,

FIGS. 34A, 34A', and 34B to 34E are views showing a process for manufacturing the solid-state imaging device according to the twenty-eighth embodiment of the invention,

FIGS. 35A to 35E are views showing the process for manufacturing the solid-state imaging device according to the twenty-eighth embodiment of the invention,

FIGS. 36A to 36C are views showing a process for manufacturing a solid-state imaging device according to a twenty-ninth embodiment of the invention,

FIGS. 37A to 37C are views showing a process for manufacturing a solid-state imaging device according to a thirtieth embodiment of the invention,

FIGS. 38A, 38A', and 38B to 38E are views showing a process for manufacturing a solid-state imaging device according to a thirty-first embodiment of the invention,

FIGS. 39A, 39A', 39B, 39B', and 39C to 39F are views showing a process for manufacturing a solid-state imaging device according to a thirty-second embodiment of the invention,

FIGS. 40A to 40D are views showing a process for manufacturing a solid-state imaging device according to a thirty-third embodiment of the invention,

FIG. 41 is a view showing a process for manufacturing a solid-state imaging device according to a thirty-fourth embodiment of the invention,

FIGS. 42A, 42A', and 42B to 42D are views showing the process for manufacturing a solid-state imaging device according to the thirty-fourth embodiment of the invention,

FIGS. 43A to 43C are views showing the process for manufacturing a solid-state imaging device according to the thirty-fourth embodiment of the invention,

FIGS. 44A and 44B are views showing a process for manufacturing a solid-state imaging device according to a thirty-fifth embodiment of the invention,

FIGS. 45A and 45B are views showing a process for manufacturing a solid-state imaging device according to a thirty-sixth embodiment of the invention,

FIGS. 46A, 46A', and 46B to 46D are views showing a process for manufacturing a solid-state imaging device according to a thirty-seventh embodiment of the invention,

FIGS. 47A to 47D are views showing a process for manufacturing a solid-state imaging device according to a thirty-eighth embodiment of the invention,

FIGS. 48A to 48D are views showing a process for manufacturing a solid-state imaging device according to a thirty-ninth embodiment of the invention,

FIG. 49 is a view showing a process for manufacturing a solid-state imaging device according to a fortieth embodiment of the invention,

FIG. 50 is a view showing a process for manufacturing a solid-state imaging device according to a forty-first embodiment of the invention,

FIGS. 51A to 51F are views showing the shape of a liquid reservoir according to the embodiments of the invention,

FIG. 52 is a view showing a structure of a resin shielding according to a forty-first embodiment of the invention,

FIGS. 53A and 53B are a sectional view showing a solid-state imaging device according to a forty-second embodiment of the invention and an enlarged sectional view showing a main part,

12

FIGS. 54A, 54A', and 54B to 54E are views showing a process for manufacturing the solid-state imaging device according to the forty-second embodiment of the invention,

FIGS. 55A to 55E are views showing the process for manufacturing the solid-state imaging device according to the forty-second embodiment of the invention,

FIGS. 56A to 56C are views showing a process for manufacturing a solid-state imaging device according to a second embodiment of the invention,

FIGS. 57A to 57C are views showing a process for manufacturing a solid-state imaging device according to a forty-fourth embodiment of the invention,

FIGS. 58A, 58A', and 58B to 58E are views showing a process for manufacturing a solid-state imaging device according to a forty-fifth embodiment of the invention,

FIGS. 59A and 59A', 59B and 59B', and 59C to 59F are views showing a process for manufacturing a solid-state imaging device according to a forty-sixth embodiment of the invention,

FIGS. 60A to 60D are views showing a process for manufacturing a solid-state imaging device according to a forty-seventh embodiment of the invention, and

FIGS. 61A and 61B are a sectional view showing a solid-state imaging device according to a forty-eighth embodiment of the invention and an enlarged sectional view showing a main part,

FIGS. 62A, 62A', and 62B to 62D are views showing a process for manufacturing the solid-state imaging device according to the forty-eighth embodiment of the invention,

FIGS. 63A to 63C are views showing the process for manufacturing the solid-state imaging device according to the forty-eighth embodiment of the invention,

FIGS. 64A and 64B are views showing a process for manufacturing a solid-state imaging device according to a forty-ninth embodiment of the invention,

FIGS. 65A and 65B is a view showing a process for manufacturing a solid-state imaging device according to a fiftieth embodiment of the invention,

FIGS. 66A, 66A', and 66B to 66D are views showing a process for manufacturing a solid-state imaging device according to a fifty-first embodiment of the invention,

FIGS. 67A to 67D is a view showing a process for manufacturing a solid-state imaging device according to a fifty-second embodiment of the invention,

FIGS. 68A to 68D are views showing a process for manufacturing a solid-state imaging device according to a fifty-third embodiment of the invention,

FIG. 69 is a view showing a process for manufacturing a solid-state imaging device according to a fifty-fourth embodiment of the invention,

FIG. 70 is a view showing a process for manufacturing a solid-state imaging device according to an fifty-fifth embodiment of the invention,

FIGS. 71A and 71B are sectional views showing a solid-state imaging device according to a fifty-sixth embodiment of the invention and an enlarged sectional view showing a main part,

FIGS. 72A, 72A', and 72B to 72D are views showing a process for manufacturing the solid-state imaging device according to the fifty-sixth embodiment of the invention,

FIGS. 73A to 73C are views showing the process for manufacturing the solid-state imaging device according to the fifty-sixth embodiment of the invention,

FIGS. 74A and 74B are views showing a process for manufacturing a solid-state imaging device according to a fifty-seventh embodiment of the invention,

FIGS. 75A and 75B are views showing a process for manufacturing a solid-state imaging device according to a fifty-eighth embodiment of the invention,

FIGS. 76A, 76A', and 76B to 76D are views showing a process for manufacturing a solid-state imaging device according to a fifty-ninth embodiment of the invention,

FIGS. 77A to 77C are views showing a process for manufacturing a solid-state imaging device according to a sixtieth embodiment of the invention,

FIGS. 78A to 78D are views showing a process for manufacturing a solid-state imaging device according to a sixth embodiment of the invention,

FIG. 79 is a view showing a process for manufacturing a solid-state imaging device according to a sixty-second embodiment of the invention,

FIG. 80 is a view showing a process for manufacturing a solid-state imaging device according to an sixty-third embodiment of the invention,

FIGS. 81A and 81B are sectional views showing a solid-state imaging device according to a sixty-fourth embodiment of the invention and an enlarged sectional view showing a main part,

FIGS. 82A to 82D are views showing a process for manufacturing the solid-state imaging device according to the sixty-fourth embodiment of the invention,

FIGS. 83A to 83C are views showing the process for manufacturing the solid-state imaging device according to the sixty-fourth embodiment of the invention,

FIGS. 84A to 84D are views showing the process for manufacturing the solid-state imaging device according to the sixty-fourth embodiment of the invention,

FIGS. 85A to 85E are views showing a process for manufacturing a solid-state imaging device according to a sixty-fifth embodiment of the invention,

FIGS. 86A and 86B are views showing a process for manufacturing a solid-state imaging device according to a sixty-sixth embodiment of the invention,

FIG. 87 is a view showing a process for manufacturing a solid-state imaging device according to a sixty-seventh embodiment of the invention, and

FIG. 88 is a view showing a process for manufacturing a solid-state imaging device according to a sixty-eighth embodiment of the invention.

In the figures, the reference numeral 100 to an IT-CCD substrate; 101 to a silicon substrate 102 to an IT-CCD; 200 to a sealing cover glass; 201 to a glass substrate; 203S to an spacer.

DETAILED DESCRIPTION OF THE PREFERRED EMBODIMENTS

Embodiments of the invention will be described below with reference to the drawings.

First Embodiment

As shown in a sectional view of FIG. 1A and an enlarged sectional view showing a main part in FIG. 1B, a solid-state imaging device has such a structure that a glass substrate 201 to be a translucent member is bonded to the surface of an IT-CCD substrate 100 comprising a silicon substrate 101 to be a semiconductor substrate provided with an IT-CCD 102 through a spacer 203S in order to have a gap C corresponding to the light receiving region of the silicon substrate 101, and furthermore, the peripheral edge of the silicon substrate 101 is individually isolated by dicing, and an electrical connection to an external circuit (not shown) can be achieved through a

bonding pad BP formed on the surface of the silicon substrate 101 in the peripheral edge portion exposed from the glass substrate 201. The spacer 203S has a height of 10 to 500 μm , and preferably 80 to 120 μm . Further, a spacer width is set to be approximately 100 to 500 μm .

As shown in the enlarged sectional view showing a main part in FIG. 1B, the IT-CCD substrate has the IT-CCD arranged on the surface thereof, and furthermore, is constituted by the silicon substrate 101 provided with an RGB color filter 46 and a microlens 50.

In the IT-CCD, a channel stopper 28 is provided in a p well 101b formed on the surface of an n-type silicon substrate 101a, and a photodiode 14 and an electric charge transfer element 33 are formed with the channel stopper 28 interposed therebetween. Herein, a p+ channel (p-type impurity) region 14b is provided in a n-type impurity region 14a to form the photodiode 14. Moreover, a vertical charge transfer channel 20 comprising an n-type impurity region having a depth of approximately 0.3 μm is formed in the p well region 101b, and a vertical charge transfer electrode 32 comprising a polycrystalline silicon layer is formed on the vertical charge transfer channel 20 through a gate insulating film 30 comprising a silicon oxide film so that an electric charge transfer element 33 is constituted. Moreover, a channel 26 for a reading gate is formed by the p-type impurity region between the electric charge transfer element 33 and the photodiode 14 on the side where a signal charge is read onto the vertical charge transfer channel 20.

The n-type impurity region 14b is exposed from the surface of the silicon substrate 101 along the channel 26 for a reading gate and a signal charge generated in the photodiode 14 is temporarily stored in the n-type impurity region 14b and is then read through the channel 26 for a reading gate.

On the other hand, the channel stopper 28 comprising a p-type impurity region is present between the vertical charge transfer channel 20 and another photodiode 14. Consequently, the photodiode 14 and the vertical charge transfer channel 20 are electrically isolated from each other and the vertical charge transfer channels 20 are isolated so as not to come in contact with each other.

Furthermore, the vertical charge transfer electrode 32 covers the channel 26 for a reading gate, and the n-type impurity region 14b is exposed and a part of the channel stopper 28 is exposed. A signal charge is transferred from the channel 26 for a reading gate which is provided below any vertical charge transfer electrode 32 to which a reading signal is applied.

The vertical charge transfer electrode 32 constitutes, together with the vertical charge transfer channel 20, a vertical charge transfer device (VCCD) 33 for transferring a signal charge generated by the pn junction of the photodiode 14 in a vertical direction. The surface of the substrate provided with the vertical charge transfer electrode 32 is covered with a surface protective film 36 and a shielding film 38 formed of tungsten is provided thereon, and only a light receiving region 40 of the photodiode is opened and other regions are shielded.

In addition, the upper layer of the vertical charge transfer electrode 32 is covered with a flattened insulating film 43 for surface flattening and a translucent resin film 44 formed on an upper layer thereof, and furthermore, a filter layer 46 is formed thereon. The filter layer 46 has a red filter layer 46R, a green filter layer 46G and a blue filter layer 46B arranged sequentially in order to make a predetermined pattern corresponding to each photodiode 14.

Moreover, the upper layer is covered with a microlens array comprising a microlens 50 formed by patterning a translucent resin containing a photosensitive resin having a refractive index of 1.3 to 2.0 by an etching method using photolithog-

raphy through a flattened insulating film **48** and then fusing the same translucent resin, and rounding the fused translucent resin by a surface tension and thereafter cooling the rounded translucent resin.

Next, description will be given to a process for manufacturing the solid-state imaging device. This method is based on a so-called wafer level CSP method in which positioning is carried out on a wafer level, collective mounting and integration are performed and isolation for each IT-CCD is then executed as shown in views illustrating the manufacturing process in FIGS. 2A to 2C and FIG. 3A to 3C. This method is characterized in that a sealing cover glass **200** having a spacer which is provided with a spacer **203S** in advance is used.

First of all, description will be given to the formation of a glass substrate having a spacer.

As shown in FIG. 2A, a silicon substrate **203** to be a spacer is stuck to the surface of a glass substrate **201** through an adhesive layer **202** comprising an ultraviolet curing type adhesive (a Cation Polymerizing Energy Line Curing Adhesive). Herein, a so-called low α ray glass (CG1: registered trademark) having fewer α rays causing an image noise is used as the glass substrate **201**. It is desirable that a material having fewer portions to be an α ray radiation nucleus should be used for the glass substrate **201** to be utilized. It is desirable that an α ray limit value should be 0.002 (DPH/cm²).

As shown in FIG. 2B, then, the silicon substrate **203** is etched by an etching method using the photolithography with a resist pattern remaining in a portion to be the spacer, and the spacer **203S** is thus formed.

As shown in FIG. 2C, thereafter, a resist is filled in a spacer region excluding an element region in a state in which the resist pattern for forming the spacer **203S** is left, and the glass substrate is etched to have a predetermined depth. Consequently, an element trench section **204** is formed as shown in FIG. 2D.

It is desirable that the spacer width should be set to be approximately 100 to 500 μm . If the spacer width is smaller than 100 μm , there is a possibility that sealing might be insufficient, and furthermore, a defective strength might be generated. If the spacer width is more than 500 μm , furthermore, there is a problem in that a division (the number of units which can be taken out of one wafer) is decreased and a size cannot be reduced. Moreover, it is desirable that a distance between the light receiving surface and the spacer should be set to be 50 μm or more in consideration of the exudation of an adhesive.

The spacer is formed by the silicon substrate. If the etching is carried out on such an etching condition that the etching speed of silicon oxide to be the main component of the glass substrate is much higher than the etching speed of silicon, therefore, it is also possible to perform the etching in a state in which the side walls of the spacer is maintained to be exposed in the element region. In the formation of the element trench section **204**, it is also possible to use a dicing blade (grindstone).

The etching condition may be selected in such a manner that a stuck foreign substance has a size of 5 μm or less in the etching of the spacer. When the stuck foreign substance has a size of 5 μm or less, it is possible to prevent an image noise from being generated if a distance between the light receiving surface and the lower surface of the glass substrate is set to be 0.08 mm or more as will be described below.

Subsequently, an adhesive layer **207** is further formed on the surface of the spacer.

In some cases in which a bubble is mixed into the adhesive layer, it causes an image noise. It is desirable that the adhesive layer **207** should have a thickness of 5 μm or less. If the

thickness is equal to or less than 5 μm , a bubble having a thickness of 5 μm or more is not present. If the distance between the light receiving surface and the lower surface of the glass substrate which will be described below is set to be 0.08 mm or more as described above, it is possible to prevent the image noise from being generated.

Moreover, the photolithography may be carried out again to form such a resist pattern as to include the whole side wall of the spacer, and the etching may be carried out through the resist pattern, thereby forming the trench section **204**. Thus, the sealing cover glass **200** provided with the trench section **204** and the spacer **203S** is obtained.

It is desirable that the spacer should have a height of 0.088 mm or more in order to prevent the generation of the image noise and should be 0.12 mm or less in order to increase a productivity of the formation of the spacer. In the case in which the spacer **203S** is to be formed by the etching, it is also possible to carry out the etching while protecting the side walls of the spacer by using a C₂F₈ plasma. Moreover, it is preferable that a bottom surface should be etched by anisotropic etching using an SF₆+O₂ plasma.

Next, an IT-CCD substrate is formed. In the formation of the element substrate, as shown in FIG. 3A, the silicon substrate **101** (a 6-inch wafer is used) is prepared in advance and a cut trench **104** is formed by a method such as etching in a region corresponding to an isolating line for isolation into each IT-CCD over the surface of the silicon substrate **101**. By using an ordinary silicon process, then, a channel stopper layer is formed, a channel region is formed and an element region such as an electric charge transfer electrode . . . is formed. Moreover, there is formed a bonding pad BP which is provided with a wiring layer on a surface and comprises a gold layer for an external connection.

As shown in FIG. 3B, then, an alignment is carried out with an alignment mark formed in the peripheral edge portion of each substrate, and the sealing cover glass **200** is mounted on the IT-CCD substrate **100** provided with the element region as described above and is thus heated so that both of them are integrated with the adhesive layer **207**. It is desirable that this process should be executed in a vacuum or an inert gas atmosphere such as a nitrogen gas. In the integration, it is also possible to use a thermosetting and ultraviolet curing adhesive as well as a thermosetting adhesive. In the case in which the surface of the IT-CCD substrate is formed of Si or metal, moreover, it is also possible to carry out bonding through surface activating cold bonding without using an adhesive.

Thereafter, CMP (chemical mechanical polishing) is carried out from the back side of the glass substrate **201** and the back side of the glass substrate **201** is removed to reach the trench section **204**.

By this step, it is possible to carry out individual isolation simultaneously with a reduction in the thickness of the glass substrate.

As shown in FIG. 3C, furthermore, the CMP is carried out from the back side of the silicon substrate **101** in the same manner to execute polishing up to the cut trench **104** portion. Consequently, individual solid-state imaging devices can be obtained by the isolation.

Thus, the collective mounting is carried out and the individual isolation is then performed without the execution of an individual alignment and an electrical connection such as wire bonding. Therefore, manufacture can easily be carried out and handling can readily be performed.

Moreover, the trench section **204** is previously formed on the glass substrate **201** and the surface is removed to have

such a depth as to reach the trench section 204 by a method such as the CMP after the mounting. Therefore, the isolation can be carried out very easily.

Furthermore, a structure in which the edge of the glass substrate 201 is positioned on the inside of the edge of the silicon substrate 101 provided with the IT-CCD and the surface of the silicon substrate 101 is exposed can be formed with high precision in a very simple process in which a concave portion is previously formed on the inside of the glass substrate and the removal is carried out to have the same depth by a method such as etch back or CMP after bonding. In addition, the structure can easily be formed with a high workability. Moreover, the individual IT-CCDs can be formed by only isolation or polishing in a state in which an element formation surface is enclosed in a gap C by the bonding. Consequently, it is possible to provide an IT-CCD which rarely damages the element and has a high reliability.

In addition, the silicon substrate is thinned to have a depth of approximately $\frac{1}{2}$ by the CMP. Therefore, a size and a thickness can be reduced. Furthermore, the thickness is reduced after the bonding to the glass substrate. Consequently, it is possible to prevent a deterioration in a mechanical strength.

Referring to a connection to the outside, moreover, the bonding pad BP provided on the silicon substrate constituting the IT-CCD substrate 100 is exposed from the sealing section formed by the spacer 203S and the glass substrate 201. Therefore, the formation can easily be carried out.

According to the structure of the invention, thus, positioning is carried out on a wafer level, and collective mounting and integration are sequentially performed for isolation every IT-CCD. Consequently, it is possible to form a solid-state imaging device which can easily be manufactured and has a high reliability.

While the wiring layer including the bonding pad is constituted by a gold layer in the first embodiment, it is apparent that the gold layer is not restricted but another metal such as aluminum or another conductor layer such as silicide can be used.

Moreover, the microlens array can also be provided by forming a transparent resin film on the surface of a substrate and forming a lens layer having a refractive index gradient in a predetermined depth by ion implantation from the same surface.

For the spacer, furthermore, it is possible to properly select a 42-alloy, metal, a glass, photosensitive polyimide and a polycarbonate resin in addition to the silicon substrate.

Moreover, it causes often generations of distortion that each of the IT-CCD substrate, spacer, and glass substrate has a different coefficient of linear thermal expansion. For preventing the generations of distortion, or remaining the distortion within an allowable range if the distortion is generated, the temperature for bonding is set to a room temperature or a temperature from 20 degree C. to 80 degree C. As the adhesive used for bonding, it is preferable to use, for example, an epoxy adhesive, an oxetanyl adhesive, silicon adhesive, acrylic adhesive, UV curing adhesive, visible curing adhesive, or such, so that the adhesive line may be thin in order to obtain a predetermined adhesive force, prevent a permeation of water, and realize a high reliable bonding.

In the first embodiment, frequency of distortion is measured when a temperature for bonding is changed. In the experiment, the temperature for bonding is changed to 20 degree C., 25 degree C., 50 degree C., 80 degree C., and 100 degree C. Then, at each of the temperature, frequency of distortions is checked in each case of using a room temperature setting adhesive and a thermosetting adhesive. In the

experiment, the adhesives mentioned above are applied for bonding of a glass substrate and a spacer and bonding of a spacer and an IT-CCD substrate.

According to the experiment, in cases that the room temperature setting adhesive is applied at each temperatures, it is obtained almost same results of the case that the thermosetting adhesive. In these cases, at 20 degree C. and 25 degree C., the generation of distortion almost never occurred. At 50 degree C., the generation of distortion within the allowable range sometimes occurred. At 80 degree C., the generation of distortion within the allowable range occurred very often. At 100 degree C., the generation of distortion over the allowable range sometimes occurred.

From the above-mentioned results of this experiment, it becomes clear that the temperature for bonding is preferably set under 80 degree C.

Additionally, if the photo-curing adhesive (UV curing adhesive, visible curing adhesive, or such) is applied, the temperature for bonding is set equal to/under 50 degree C. Therefore, the generation of distortion never occurred and it is possible to obtain an excellent result.

Furthermore, a simulation for obtaining the optimum value of a distance between a sensor and a glass was carried out. Simulation conditions were set to have an exit pupil of 3.5 mm, an F value of 3.5 and a refractive index of a glass substrate of 1.5.

First of all, in the case in which the lower surface of the glass substrate made a defect having a size of 5 μm , a distance between the light receiving surface of a photodiode section of a solid-state imaging element and the lower surface of the glass substrate was changed and the relationship between the distance and the density of a shadow in which the defect is projected onto the solid-state imaging element was measured. The result of the simulation is shown in the following Table 1.

As is apparent from the Table 1, if the distance between the light receiving surface and the glass substrate is 0.07 mm, the density of the shadow is 4.7% which is more than 4%. Accordingly, it is desirable that the distance between the light receiving surface and the glass substrate should be equal to or more than 0.08 mm.

TABLE 1

Distance (mm) between lower surface and light-receiving surface	Density of shadow (%)
0.01	
0.02	
0.03	
0.04	
0.05	
0.06	8.3
0.07	4.1
0.08	4.8
0.09	3.7
0.01	3.2
0.1	2.5

Moreover, Table 2 shows a result obtained by measuring the relationship between a distance between the light receiving surface and the upper surface of the glass substrate and the density of a shadow in which a defect is projected onto a solid-state imaging element in the case in which a defect having a size of 20 μm is present on the upper surface of the glass substrate.

TABLE 2

Distance (mm) between Light-receiving surface and upper surface	Density of shadow (%)
0.3	8.3
0.4	5.1
0.5	3.5
0.6	2.5
0.7	1.9
0.8	1.5
0.9	1.2
1.0	1.0

As is apparent from the Table, in the case in which the distance between the light receiving surface and the upper surface of the glass substrate is equal to or less than 0.4 mm, the density of the shadow is equal to or more than 4%.

In the case in which a background is uniform, for example, a sky, the density of the shadow projected onto the light receiving surface of the solid-state imaging element is 4% and the shadow is started to be seen over a printed image. When the density of the shadow is set to be less than 4%, therefore, there is no influence of such a defect.

From the result of the experiment described above, an interval between the surface of the glass substrate and the CCD is to be 0.08 mm. It is apparent that the interval should be desirably set to be 0.12 mm.

Moreover, it is sufficient that the distance between the light receiving surface and the upper surface of the glass substrate is equal to or more than 0.5 mm even if a dust having a size of 20 μm is put on the surface of the glass substrate.

In the same simulation, furthermore, there was obtained a result in which it is sufficient that the distance from the light receiving surface and the upper surface of the glass substrate is equal to or more than 1.5 mm with an F value of 11. From the result described above, when the distance between the light receiving surface and the upper surface of the glass substrate is set to be 0.5 to 1.5 mm, an invisible dust can be prevented from making an image noise if any. Moreover, it is desirable that the distance between the light receiving surface and the surface of the glass substrate should be set to be 1.5 mm or less in consideration of the problem of the size of the device, a strength and a deterioration in the productivity of dicing because of a great glass thickness.

Second Embodiment

Next, a second embodiment of the invention will be described.

In the first embodiment, the cut trench **104** is previously formed on the silicon substrate **101** constituting the IT-CCD substrate **100**, the IT-CCD substrate **100** and the sealing cover glass **200** are bonded to each other by using the spacer **203S** formed of the same silicon as that of the solid state image pick-up element substrate **100**, and the CMP is then carried out to reach the cut trench **104** from the back side so that the thickness of the silicon substrate **101** is reduced and the isolation is executed simultaneously. This example is characterized in that the isolation is carried out without forming the cut trench on the silicon substrate **101** and an exact thickness is maintained. Other portions are formed in the same manner as those in the first embodiment.

More specifically, FIGS. **4A** to **4D** show bonding and isolating steps. As shown in FIG. **4A**, the silicon substrate **101** is set to be a starting material, and a channel stopper layer is formed, a channel region is formed and an element region

such as an electric charge transfer electrode or such is formed by using an ordinary silicon process. Moreover, there is formed a bonding pad BP which is provided with a wiring layer on a surface and comprises a gold layer for an external connection.

As shown in FIG. **4B**, then, an alignment is carried out with an alignment mark formed in the peripheral edge portion of each substrate, and a sealing cover glass **200** is mounted on an IT-CCD substrate **100** formed as described above and is thus heated so that both of them are integrated with an adhesive layer **207**. In this case, since a cut trench is not formed on the silicon substrate **101**, a mechanical strength is great.

As shown in FIG. **4C**, thereafter, CMP (chemical mechanical polishing) is carried out from the back side of a glass substrate **201** and the back side of the glass substrate **201** is removed to reach the trench section **204** in the same manner as in the first embodiment.

By this step, it is possible to carry out individual isolation simultaneously with a reduction in the thickness of the glass substrate.

As shown in FIG. **4D**, furthermore, cutting is carried out by means of a diamond blade (a grindstone) from the glass substrate **201** side so that isolation into individual solid-state imaging devices is performed.

According to this method, it is possible to form a device which is thicker than the solid-state imaging device obtained in the first embodiment and has a high reliability.

Third Embodiment

Next, a third embodiment of the invention will be described.

In the first embodiment, the cut trench **104** is previously formed on the silicon substrate **101** constituting the IT-CCD substrate **100** and the CMP is then carried out to reach the cut trench **104** from the back side after the bonding so that the thickness of the silicon substrate **101** is reduced and the isolation is executed simultaneously. In this example, a dummy plate **301** formed by a silicon substrate having a thickness of 50 to 700 μm is stuck to the back side of the silicon substrate **101** through an adhesive layer **302** and a cut trench **304** having such a depth as to reach the dummy plate **301** is formed after the sticking.

At the isolating step, accordingly, the adhesive layer **302** may be softened to eliminate an adhesiveness, thereby removing the dummy plate **301**.

Other portions are formed in the same manner as those in the first embodiment.

More specifically, FIGS. **5A** to **5E** show the bonding and isolating steps. The silicon substrate **101** is set to be a starting material, and a channel stopper layer is formed, a channel region is formed and an element region such as an electric charge transfer electrode . . . is formed by using an ordinary silicon process. Moreover, there is formed a bonding pad BP which is provided with a wiring layer on a surface and comprises a gold layer for an external connection. As shown in FIG. **5A**, then, the dummy plate **301** formed by a silicon substrate is stuck to the back side of the silicon substrate **101** through the adhesive layer **302**.

As shown in FIG. **5B**, thereafter, the cut trench **304** is formed by using a diamond blade (a grindstone) from the element formation surface side of the silicon substrate **101**.

As shown in FIG. **5C**, subsequently, an alignment is carried out with an alignment mark (not shown) formed on the peripheral edge portions of an IT-CCD substrate **100** and a sealing cover glass **200**, and the sealing cover glass **200** is mounted on the IT-CCD substrate **100** formed as described

21

above and is thus heated so that both of them are integrated with an adhesive layer 207. The glass substrate comprising a spacer 203S and the adhesive layer 207 formed at the steps in FIGS. 2A to 2C is used. In this case, although the cut trench 304 is formed to penetrate through the silicon substrate 101, a mechanical strength is great because of the fixation of the dummy plate 301.

As shown in FIG. 5D, thereafter, CMP (chemical mechanical polishing) is carried out from the back side of a glass substrate 201 and the back side of the glass substrate 201 is removed to reach the trench section 204 in the same manner as in the first embodiment.

By this step, it is possible to carry out individual isolation simultaneously with a reduction in the thickness of the glass substrate.

As shown in FIG. 5E, furthermore, the adhesive layer 302 provided on the back face of the silicon substrate 101 is softened to remove the dummy plate 301, thereby carrying out isolation into individual solid-state imaging devices. It is desirable that a material having a lower softening point than that of the adhesive layer 202 for bonding the spacer 203S to the glass substrate 201 should be selected for the adhesive layer 302.

According to this method, the IT-CCD substrate 100 is subjected to dicing over the dummy plate 301 prior to the bonding. As compared with the solid-state imaging device obtained in the first embodiment, therefore, a stress to be applied after the bonding is lessened and a manufacturing yield can be more enhanced. Moreover, it is possible to enhance the reliability of an IT-CCD.

While the bonding of the glass substrate to the space may be carried out by using the adhesive layer in the embodiments, it is also possible to apply anode bonding or surface activating cold bonding. According to the anode bonding, it is possible to easily obtain firm bonding.

Moreover, while the CMP has been used in the reduction in the thickness of the glass substrate in the first to third embodiments, it is also possible to apply a grinding method, a polishing method and an etching method.

Fourth Embodiment

Next, a fourth embodiment of the invention will be described.

In the first embodiment, the trench section 204 is previously formed in the region corresponding to the element region of the glass substrate 201 constituting the sealing cover glass 200, the IT-CCD substrate is bonded to the glass substrate and the CMP is then carried out from the back side of the glass substrate 201, thereby performing isolation into the individual elements. In the embodiment, a glass substrate having no concave portion is bonded and the periphery of a cutting line is evaporated by dicing or laser during isolation, and the edge of the glass substrate 201 of each IT-CCD is regulated to be placed on the inside of the edge of the silicon substrate 101 constituting the IT-CCD substrate 100. Other portions are formed in the same manner as those in the first embodiment.

More specifically, in this method, the processing of the glass substrate is completed when the spacer is formed as shown in FIG. 2B. A glass substrate obtained by bonding a spacer 203S to the plate-shaped glass substrate 201 is used as a starting material.

As shown in FIG. 6A, the silicon substrate 101 (a 6-inch wafer is used) is prepared in advance and a cut trench 104 is formed by a method such as etching in a region corresponding

22

to an isolating line for isolation into each IT-CCD. By using an ordinary silicon process, then, a channel stopper layer is formed, a channel region is formed and an element region such as an electric charge transfer electrode . . . is formed. Moreover, there is formed a bonding pad BP which is provided with a wiring layer on a surface and comprises a gold layer for an external connection.

As shown in FIG. 6B, then, an alignment is carried out with an alignment mark formed in the peripheral edge portion of each substrate, and a sealing cover glass 200 is mounted on the IT-CCD substrate 100 formed as described above and is thus heated so that both of them are integrated with an adhesive layer 207.

As shown in FIG. 6C, thereafter, the periphery of a cutting line is evaporated from the back side of the glass substrate by dicing or laser and the edge of the glass substrate 201 of each IT-CCD is regulated to be placed on the inside of the edge of the silicon substrate 101 constituting the IT-CCD substrate 100.

As shown in FIG. 6D, furthermore, the CMP is carried out from the back side of the silicon substrate 101 in the same manner to carry out polishing up to the cut trench 104 portion, thereby performing isolation into individual solid-state imaging devices. Moreover, this step is not restricted to the CMP but grinding, polishing and etching may be used.

Thus, collective mounting is carried out and individual isolation is then performed. Therefore, manufacture can easily be carried out and handling can readily be performed.

Furthermore, the trench section 204 is not previously formed on the glass substrate 201 but the edge is removed by the evaporation through the dicing or the laser. Consequently, the isolation can be carried out very easily.

Thus, the structure in which the edge of the glass substrate 201 is placed on the inside of the edge of the silicon substrate 101 mounting a CCD and the surface of the silicon substrate 101 is exposed can be formed with high precision by a simple process for carrying out the evaporation through the dicing or the laser.

In addition, the glass substrate maintains the same thickness till the isolating step. Consequently, it is possible to reduce a warp and a strain.

Fifth Embodiment

Next, a fifth embodiment of the invention will be described.

In the fourth embodiment, the cut trench 104 is previously formed on the silicon substrate 101 constituting the IT-CCD substrate 100 and the CMP is then carried out to reach the cut trench 104 from the back side after the bonding so that the thickness of the silicon substrate 101 is reduced and the isolation is executed simultaneously. This example is characterized in that a cut trench is not formed on the silicon substrate 101 but isolation is carried out and an exact thickness is maintained. In the same manner as the fourth embodiment, moreover, bonding is carried out without the formation of a trench section 204 on a glass substrate 201 and an edge portion is evaporated during the isolation. Other portions are formed in the same manner as those in the first embodiment.

More specifically, FIGS. 7A to 7D show the bonding and isolating steps. As shown in FIG. 7A, the silicon substrate 101 is set to be a starting material, and a channel stopper layer is formed, a channel region is formed and an element region such as an electric charge transfer electrode, or such is formed by using an ordinary silicon process. Moreover, there is formed a bonding pad BP which is provided with a wiring layer on a surface and comprises a gold layer for an external connection.

As shown in FIG. 7B, then, an alignment is carried out with an alignment mark formed in the peripheral edge portion of each substrate, and a sealing cover glass **200** is mounted on the IT-CCD substrate **100** formed as described above and is thus heated so that both of them are integrated with an adhesive layer **207**. In this case, since neither a cut trench nor a concave portion is formed on both the silicon substrate **101** and the glass substrate **201**, a mechanical strength is great.

As shown in FIG. 7C, then, the periphery of the cutting line is evaporated from the back side of the glass substrate **201** by dicing or laser and the edge of the glass substrate **201** of each IT-CCD is regulated to be placed on the inside of the edge of the silicon substrate **101** constituting the IT-CCD substrate **100** and isolation is thus performed in the same manner as in the fourth embodiment.

As shown in FIG. 7D, finally, cutting is carried out by means of a diamond blade (a grindstone) from the glass substrate **201** side so that the isolation into individual solid-state imaging devices is performed.

According to the method, it is possible to form a device which is thicker than the solid-state imaging device obtained in the first embodiment and has a high reliability.

Sixth Embodiment

Next, a sixth embodiment of the invention will be described.

In the fourth embodiment, the cut trench **104** is previously formed on the silicon substrate **101** constituting the IT-CCD substrate **100** and the CMP is then carried out from the back side so that the isolation is executed. In the fifth embodiment, moreover, the cut trench **104** is previously formed on the silicon substrate **101** constituting the IT-CCD substrate **100** and cutting is carried out by means of a diamond blade (a grindstone) after bonding, thereby isolating the silicon substrate **101**. In this example, a dummy plate **301** formed by a silicon substrate having a thickness of 50 to 700 μm is stuck to the back side of the silicon substrate **101** through an adhesive layer **302** and a cut trench **304** having such a depth as to reach the dummy plate **301** is formed after the sticking in such a manner that the isolation of the silicon substrate **101** is not required after the sticking of a sealing cover glass **200** to the IT-CCD substrate **100**.

At the isolating step, accordingly, the adhesive layer **302** can be softened to remove the dummy plate **301**.

Other portions are formed in the same manner as those in the fourth and fifth embodiments.

More specifically, FIGS. 8A to 8E show the bonding and isolating steps. The silicon substrate **101** is set to be a starting material, and a channel stopper layer is formed, a channel region is formed and an element region such as an electric charge transfer electrode, or such is formed by using an ordinary silicon process. Moreover, there is formed a bonding pad BP which is provided with a wiring layer on a surface and comprises a gold layer for an external connection. As shown in FIG. 8A, then, the dummy plate **301** formed by a silicon plate having a thickness of 50 to 700 μm is stuck to the back side of the silicon substrate **101** through the adhesive layer **302**.

As shown in FIG. 8B, thereafter, the cut trench **304** is formed by using a diamond blade (a grindstone) from the element formation surface side of the silicon substrate **101**.

As shown in FIG. 8C, subsequently, an alignment is carried out with an alignment mark (not shown) formed in the peripheral edge portions of the IT-CCD substrate **100** and the sealing cover glass **200**, and the sealing cover glass **200** is mounted on the IT-CCD substrate **100** formed as described

above and is thus heated so that both of them are integrated with an adhesive layer **207**. The glass substrate comprising the spacer **203S** and the adhesive layer **207** formed at the steps in FIGS. 8A to 8C is used. In this case, although the cut trench **304** is formed to penetrate through the silicon substrate **101**, a mechanical strength is great because of the fixation of the dummy plate **301**.

As shown in FIG. 8D, then, the periphery of a cutting line is evaporated from the back side of a glass substrate **201** by dicing or laser and the edge of the glass substrate **201** of each IT-CCD is regulated to be placed on the inside of the edge of the silicon substrate **101** constituting the IT-CCD substrate **100**, and isolation is thus performed in the same manner as in the fourth embodiment.

As shown in FIG. 8E, furthermore, the adhesive layer **302** provided on the back face of the silicon substrate **101** is softened to remove the dummy plate **301**, thereby performing the isolation into the individual solid-state imaging devices. It is desirable that a material having a lower softening point than that of the adhesive layer **202** for bonding the spacer **203S** to the glass substrate **201** should be selected for the adhesive layer **302**.

According to this method, the IT-CCD substrate **100** is subjected to dicing over the dummy plate **301** prior to the bonding. As compared with the solid-state imaging device obtained in the first embodiment, therefore, a stress to be applied after the bonding is lessened and a manufacturing yield can be more enhanced. Moreover, it is possible to enhance the reliability of an IT-CCD.

In the fourth to sixth embodiments, the glass substrate may be cut by scribing or etching.

Seventh Embodiment

Next, a seventh embodiment of the invention will be described.

In the sixth embodiment, the dummy plate **301** formed by a silicon plate having a thickness of 50 to 700 μm is stuck to the back side of the silicon substrate **101** through the adhesive layer **302** and the cut trench **304** having such a depth as to reach the dummy plate **301** is formed after the sticking, and the adhesive layer **302** is softened to remove the dummy plate **301**, thereby carrying out the isolation at the step of performing the isolation into the individual IT-CCDs after the bonding to the glass substrate **201**. In the embodiment, a dummy plate **401** formed by a glass plate having a thickness of 50 to 700 μm is stuck to the back side of a glass substrate **201** through an adhesive layer **402** and a concave portion **404** having such a depth as to reach the dummy plate **401** is formed after the sticking. At the step of performing the isolation into individual IT-CCDs after the bonding to the glass substrate **201**, the adhesive layer **402** is softened to remove the dummy plate **401**, thereby carrying out the isolation. Other portions are formed in the same manner as those in the sixth embodiment.

Referring to the silicon substrate **101** constituting an IT-CCD substrate **100**, in the same manner as in the second and fourth embodiments, a silicon substrate on which neither a cut trench nor a dummy plate is previously formed is used and is finally cut and isolated by means of a diamond blade (a grindstone).

More specifically, the bonding and isolating steps are shown in FIGS. 9A to 9E.

First of all, as shown in FIG. 9A, the dummy plate **401** formed by a glass plate having a thickness of 50 to 700 μm is stuck to the back side of the glass substrate **201** through the adhesive layer **402**, and furthermore, a silicon substrate **203** is

25

stuck through an adhesive layer **202** after the sticking and the silicon substrate **203** is formed into a spacer **203S** by an etching method using photolithography in the same manner as in the first embodiment illustrated in FIGS. **2A** to **2C**.

As shown in FIG. **9B**, then, a region corresponding to an IT-CCD is selectively etched again and a concave portion **404** having such a depth as to reach the dummy plate **401** is formed in the same manner as in the first embodiment. Moreover, the formation may be carried out by half dicing.

Furthermore, the silicon substrate **101** is set to be a starting material, and a channel stopper layer is formed, a channel region is formed and an element region such as an electric charge transfer electrode . . . is formed by using an ordinary silicon process. Moreover, there is formed a bonding pad BP which is provided with a wiring layer on a surface and comprises a gold layer for an external connection. As shown in FIG. **9C** then, an alignment is carried out with an alignment mark (not shown) formed in the peripheral edge portions of the IT-CCD substrate **100** thus formed and a sealing cover glass **200**, and the sealing cover glass **200** having the dummy plate **401** is mounted on the IT-CCD substrate **100** formed as described above and is thus heated so that both of them are integrated with an adhesive layer **207**.

As shown FIG. **9D**, thereafter, heating is carried out to soften the adhesive layer **402**, thereby removing the dummy plate **401**. Thus, the glass substrate **201** is isolated.

As shown in FIG. **9E**, subsequently, the IT-CCD substrate formed by the silicon substrate **101** is cut by using a diamond blade (a grindstone) to carry out isolation into individual solid-state imaging devices.

According to this method, the glass substrate **201** constituting the sealing cover glass **200** is isolated by dicing or etching in advance over the dummy plate **401** prior to the bonding. As compared with the glass substrate obtained in the first embodiment, therefore, a stress to be applied after the bonding is lessened and a manufacturing yield can be more enhanced. Moreover, it is possible to enhance the reliability of an IT-CCD.

Eighth Embodiment

Next, an eighth embodiment of the invention will be described.

In the seventh embodiment, the bonding is exactly carried out without previously forming the cut trench **104** on the silicon substrate **101** constituting the IT-CCD substrate **100** and the cutting is finally performed by using the diamond blade (the grindstone). This example is characterized in that the cut trench **104** is previously formed on the silicon substrate **101** constituting the IT-CCD substrate **100** and CMP is carried out to reach the cut trench **104** from the back side after bonding, thereby performing isolation while reducing the thickness of the silicon substrate **101**. Other portions are formed in the same manner as those in the seventh embodiment.

More specifically, FIGS. **10A** to **10D** show the bonding and isolating steps. As shown in FIG. **10A**, the silicon substrate **101** provided with the cut trench **104** is set to be a starting material, and a channel stopper layer is formed, a channel region is formed and an element region such as an electric charge transfer electrode . . . is formed by using an ordinary silicon process. Moreover, there is formed a bonding pad BP which is provided with a wiring layer on a surface and comprises a gold layer for an external connection.

As shown in FIG. **10B**, then, an alignment is carried out with an alignment mark formed in the peripheral edge portion of each substrate, and the sealing cover glass **200** having the

26

dummy substrate **401** formed as in the seventh embodiment is mounted on the IT-CCD substrate **100** and both of them are integrated by cold direct bonding. While the formation is carried out by the direct bonding without using an adhesive layer, the bonding may be performed with an adhesive layer **207**.

As shown in FIG. **10C**, thereafter, CMP (chemical mechanical polishing) is carried out from the back side of the IT-CCD substrate **100** and the back side of the silicon substrate **101** is removed to reach the cut trench **104**.

By this step, it is possible to individually isolate the IT-CCD substrate simultaneously with a reduction in a thickness thereof. Herein, grinding, polishing or etching may be used in place of the CMP.

As shown in FIG. **10D**, subsequently, heating is carried out to soften an adhesive layer **402**, thereby removing the dummy substrate **401**. By this step, the isolation can easily be carried out so that the solid-state imaging device is formed.

Ninth Embodiment

Next, a ninth embodiment of the invention will be described.

In the seventh embodiment, the bonding is exactly carried out without previously forming the cut trench **104** on the silicon substrate **101** constituting the IT-CCD substrate **100** and the cutting is finally performed by using the diamond blade (the grindstone). In this example, a dummy plate is previously formed on the silicon substrate **101** constituting the IT-CCD substrate **100** and a glass substrate **201** constituting a sealing cover glass **200**, and the cut trench **104** and a trench section **204** are previously formed prior to bonding, and adhesive layers **402** and **302** are softened to remove dummy plates **301** and **401**, thereby carrying out isolation after the bonding. Other portions are formed in the same manner as those in the seventh embodiment.

More specifically, FIGS. **11A** to **11D** show the bonding and isolating steps. As shown in FIG. **11A**, the silicon substrate **101** having the dummy plate **301** stuck thereto is set to be a starting material, and a channel stopper layer is formed, a channel region is formed and an element region such as an electric charge transfer electrode is formed by using an ordinary silicon process. Moreover, there is formed a bonding pad BP which is provided with a wiring layer on a surface and comprises a gold layer for an external connection.

As shown in FIG. **11B**, then, a cut trench **304** is formed to reach the dummy plate **301**.

The dummy plate **401** is stuck to the sealing cover glass **200** in the same manner as in the seventh and eighth embodiments, and furthermore, a concave portion **404** is formed by etching or dicing.

As shown in FIG. **11C**, thereafter, an alignment is carried out with an alignment mark formed in the peripheral edge portion of each substrate, and the sealing cover glass **200** having the dummy substrate **401** formed as in the seventh embodiment is mounted on the IT-CCD substrate **100** having the dummy plate **301** and heating is carried out to integrate both of them with an adhesive layer **207**.

As shown in FIG. **11D**, subsequently, the adhesive layers **402** and **203** are softened to remove the dummy plates **301** and **401** so that isolation into individual IT-CCDs can be carried out.

These adhesive layers **302** and **402** to be used may have almost equal softening temperatures and may be thus softened at the same time.

27

Moreover, one of the adhesive layers **302** and **402** may be removed to carry out fixation by taping, and the other adhesive layer **302** or **402** may be softened to be removed.

According to such a structure, an extra stress is not applied after the bonding. Therefore, it is possible to reduce a damage on the IT-CCD.

Tenth Embodiment

Next, a tenth embodiment of the invention will be described.

In the first to ninth embodiments, the silicon substrate **203** to be a spacer is stuck to the glass substrate **201** through an adhesive, and the silicon substrate **203** is subjected to the patterning to form the cut trench **204** by an etching method using photolithography in the formation of the sealing cover glass **200** provided with the spacer **203S** as shown in FIGS. **2A** and **2B**. In the embodiment, as shown in FIGS. **12A** and **12B**, the spacer **203S** is etched over a dummy plate by using a dummy plate **501** and sticking to the glass substrate **201** is then carried out with an adhesive layer **202**. Other portions are formed in the same manner as those in the embodiments.

More specifically, as shown in FIG. **12A**, the silicon substrate **203** to be the spacer is stuck to the dummy plate **501** formed by a silicon substrate through an adhesive layer **502** having a softening temperature of approximately 50 to 150 degree C. Then, the silicon substrate **203** is subjected to patterning by an etching method using photolithography, thereby forming the spacer **203S**.

As shown in FIG. **12B**, then, the glass substrate **201** is stuck to the spacer **203S** side through the adhesive layer **202** having a softening temperature of approximately 100 to 200 degree C.

Thus, the glass substrate **201** is stuck and heating is then carried out up to approximately 50 to 150 degree C. to soften the adhesive layer **502**, thereby removing the dummy plate **501**. Consequently, the sealing cover glass **200** having a spacer is formed.

According to such a method, it is not necessary to process the spacer over the glass substrate. Consequently, it is possible to prevent a scratch from being made on the glass substrate **201**, thereby causing a blur.

It is sufficient that the adhesive layer **502** for sticking the dummy plate is resistant to a baking temperature in a photolithographic process. Moreover, since the dummy plate **501** needs to be removed, the adhesive layer **202** for sticking the spacer **203S** to the glass substrate **201** needs to have a much higher softening temperature than that of the adhesive layer **502**.

In the case in which a concave portion is to be formed on the glass plate, moreover, it is preferable that the trench section **204** should be formed by dicing or etching prior to the sticking as shown in FIG. **13**. Furthermore, it is preferable that a concavo-convex portion should be formed by the dicing or the etching after the dummy plate **501** is removed.

The bonding step and the cutting step are the same as those in FIGS. **3** to **5** described in the first to third embodiments.

Eleventh Embodiment

Next, an eleventh embodiment of the invention will be described.

While the spacer **203S** is separately formed and is stuck through the adhesive layer in the first to tenth embodiments, a concave portion **205** is formed and a spacer **206** is thus provided on a glass substrate **201** by an etching method using

28

photolithography in this example. Other portions are formed in the same manner as those in the embodiments.

More specifically, as shown in FIG. **14A**, the glass substrate **201** is prepared.

As shown in FIG. **14B**, then, the concave portion **205** is formed by the etching method using the photolithography. Consequently, a glass substrate comprising the spacer **206** is formed.

According to such a structure, the spacer **206** is integrally formed. Therefore, manufacture can easily be carried out and a shift is not generated, and furthermore, there is no possibility that a strain might be generated in a bonded portion.

Twelfth Embodiment

Next, a twelfth embodiment of the invention will be described.

While the description has been given to the method of forming the sealing cover glass **200** having the spacer **206** formed integrally therewith in the eleventh embodiment, it is also possible to form a trench section **204** by etching as shown in FIGS. **15A** to **15C**.

In this example, a concave portion **205** is formed on a glass substrate **201** by an etching method using photolithography so that the spacer **206** is formed integrally. Then, the trench section **204** is formed. Consequently, the trench section **204** of the glass substrate for positioning the edge of the sealing cover glass **200** on the inside of the edge of an IT-CCD substrate **100** is formed by the etching. Accordingly, the generation of a strain is reduced and the isolating step can be thereby carried out easily.

More specifically, as shown in FIG. **15A**, the glass substrate **201** is prepared.

As shown in FIG. **15B**, then, the concave portion **205** is formed on the glass substrate **201** by the etching method using the photolithography.

As shown in FIG. **15C**, thereafter, the etching is further carried out more deeply by the etching method using the photolithography to form the trench section **204**. Thus, the spacer **206** is formed integrally.

Although these processing steps require the etching twice because of different etching depths, it is also possible to form a resist pattern to be a mask in a two-layer structure, to etch the trench section **204** for forming the spacer, and to then remove only the resist pattern of an upper layer selectively, thereby carrying out the etching using, as a mask, only the resist pattern on the lower layer side.

Moreover, the bonding and isolating steps are the same as those in FIGS. **3** to **5** described in the first to third embodiments.

Thirteenth Embodiment

Next, a thirteenth embodiment of the invention will be described.

While the description has been given to the method of forming the sealing cover glass **200** having the spacer **206** formed integrally therewith in the eleventh and twelfth embodiments, it is also possible to stick a silicon substrate **203** for a spacer to a glass substrate **201** provided with a trench section **204** and to selectively remove the silicon substrate **203** by an etching method using photolithography, thereby forming a spacer **203S** as shown in FIGS. **16A** to **16D**. Other portions are formed in the same manner as those in the eleventh and twelfth embodiments.

In this example, the trench section **204** is formed on the glass substrate **201** by the etching method using the photoli-

29

thography and the spacer **206** is formed integrally, and furthermore, the trench section **204** of the glass substrate **201** for positioning the edge of the sealing cover glass **200** on the inside of the edge of an IT-CCD substrate **100** is formed by the etching. Accordingly, the generation of a strain can be reduced and the isolating step can easily be carried out.

More specifically, as shown in FIG. **16A**, the glass substrate **201** is prepared.

As shown in FIG. **16B**, then, the trench section **204** is formed on the glass substrate **201** by the etching method using the photolithography.

As shown in FIG. **16C**, thereafter, the silicon substrate **203** to be a substrate for a spacer is stuck through an adhesive layer **202**.

As shown in FIG. **16D**, furthermore, the spacer **203S** is formed integrally by the etching method using the photolithography.

By this method, similarly, it is possible to form the sealing cover glass **200** having a spacer with high precision and a high reliability.

The bonding and isolating steps are the same as those in FIGS. **3** to **5** described in the first to third embodiments.

Fourteenth Embodiment

Next, a fourteenth embodiment of the invention will be described.

In the thirteenth embodiment, the silicon substrate **203** to be a spacer is stuck to the glass substrate **201** through an adhesive, and the silicon substrate **203** is subjected to the patterning to form the sealing cover glass **200** by an etching method using photolithography so that the sealing cover glass **200** is formed as shown in FIGS. **16A** to **16D**. In the embodiment, as shown in FIGS. **17A** and **17B**, a spacer **203S** is subjected to the patterning over a dummy plate by using a dummy plate **501** and sticking to the glass substrate **201** provided with a trench section **204** is then carried out with an adhesive layer **202**. Other portions are formed in the same manner as those in the thirteenth embodiment.

More specifically, the silicon substrate **203** to be the spacer is stuck to the dummy plate **501** formed by a silicon substrate through an adhesive layer **502** having a softening temperature of approximately 50 to 150 degree C. As shown in FIG. **17A**, then, the silicon substrate **203** is subjected to the patterning by the etching method using the photolithography, thereby forming the spacer **203S**.

As shown in FIG. **17B**, thereafter, the glass substrate **201** having the trench section **204** is stuck to the spacer **203S** side through the adhesive layer **202** having a softening temperature of approximately 100 to 200 degree C.

Thus, the glass substrate **201** is stuck and heating is then carried out up to approximately 50 to 150 degree C. to soften the adhesive layer **502**, thereby removing the dummy plate **501**. Consequently, the sealing cover glass **200** having a spacer is formed as shown in FIG. **17C**.

According to such a method, it is not necessary to process the spacer over the glass substrate. Consequently, it is possible to prevent a scratch from being made on the glass substrate **201**, thereby causing a blur.

The bonding and isolating steps are the same as those in FIGS. **3** to **5** described in the first to third embodiments.

Fifteenth Embodiment

Next, a fifteenth embodiment of the invention will be described.

In the twelfth to fourteenth embodiments, the description has been given to the process for manufacturing the sealing cover glass **200** having the spacer which comprises the trench section **204** for easily carrying out the isolating step. The

30

fifteenth to seventeenth embodiments are characterized in that sticking to a dummy plate **401** is carried out and the trench section **204** is formed so that the glass substrate itself is previously isolated prior to the bonding, and an adhesive layer **402** is softened after the bonding, thereby removing the dummy plate and carrying out isolation into individual IT-CCDs. Other portions are formed in the same manner as those in the fourteenth embodiment.

While the trench section **204** is formed on the glass substrate of a sealing cover glass of a spacer member type and the glass substrate can easily be isolated in the embodiments shown in FIGS. **15A** to **15C**, the dummy plate **401** formed by the glass substrate is used through the adhesive layer **402**, and the dummy plate is removed so that the isolation can easily be carried out as shown in FIG. **18**.

A glass plate is used as a starting material, and the trench section **204** and a spacer **26** are formed by an etching method using photolithography after the dummy plate is stuck.

According to such a structure, it is sufficient that the adhesive layer **402** is only softened by heating during division and the division can be thereby carried out very easily.

The bonding and isolating steps are the same as those described in the seventh to ninth embodiments.

Sixteenth Embodiment

Next, a sixteenth embodiment of the invention will be described.

This example is characterized in that the glass substrate **201** of such a type as to stick the spacer **203S** to the glass plate having a concave portion described in the thirteenth embodiment is stuck to a dummy plate **401** and a trench section **204** is formed so that the glass substrate itself is previously isolated prior to the bonding, and an adhesive layer **402** is softened after the bonding, thereby removing the dummy plate and carrying out isolation into individual IT-CCDs. Other portions are formed in the same manner as those in the thirteenth embodiment.

In the embodiment, the dummy plate **401** is stuck through the adhesive layer **402** to the spacer member type glass plate according to the embodiment shown in FIGS. **16A** and **16B** and the trench section **204** is formed as shown in FIGS. **19A** and **19B**.

A glass plate is used as a starting material, and the trench section **204** having such a depth as to reach the dummy plate and the spacer **203S** are formed in the same manner as in the thirteenth embodiment after the dummy plate is stuck.

More specifically, as shown in FIG. **19A**, the dummy substrate **401** is stuck to the glass substrate **201** through the adhesive layer **402**.

As shown in FIG. **19B**, then, the glass substrate **201** is etched by using photolithography and the trench section reaching the dummy substrate **401** from the surface of the glass substrate **201** is formed.

As shown in FIG. **19C**, thereafter, a silicon substrate **203** for the spacer is stuck through an adhesive layer **202**.

As shown in FIG. **19D**, subsequently, the silicon substrate **203** is selectively removed by the etching method using the photolithography to form the spacer **203S**.

According to such a structure, bonding to an IT-CCD substrate **100** is carried out, and then, the adhesive layer **402** is only softened by heating in dicing. Thus, division can be carried out very easily.

31

The bonding and isolating steps are the same as those described in the seventh to ninth embodiments.

Seventeenth Embodiment

Next, a seventeenth embodiment of the invention will be described.

This example is characterized in that the glass substrate **201** of such a type as to stick the spacer **203S** patterned over the dummy plate **501** to the glass plate having a concave portion described in the fourteenth embodiment (FIG. 17) is stuck to a dummy plate **401** and a trench section **204** is formed so that the glass substrate itself is previously isolated prior to the bonding, and an adhesive layer **402** is softened after the bonding, thereby removing the dummy plate and carrying out isolation into individual IT-CCDs. Other portions are formed in the same manner as those in the fourteenth embodiment.

In the embodiment, the dummy plate **401** is stuck to a spacer sticking type glass plate according to the embodiment shown in FIGS. 17A and 17B through the adhesive layer **402** as shown in FIGS. 20A to 20C.

A glass plate is used as a starting material, and the trench section **204** having such a depth as to reach the dummy plate and the spacer **203S** are formed in the same manner as in the fifteenth embodiment after the dummy plate is stuck.

More specifically, the silicon substrate **203** to be the spacer is stuck to a dummy plate **501** formed by a silicon substrate through an adhesive layer **502**, and then, the silicon substrate **203** is subjected to patterning by an etching method using photolithography, thereby forming the spacer **203S** as shown in FIG. 20A.

As shown in FIG. 20B, thereafter, the glass substrate **201** having the trench section **204** formed to reach the dummy plate **401** is stuck to the spacer **203S** side through an adhesive layer **202**.

Thus, the glass substrate **201** is stuck and the adhesive layer **502** is then softened to remove the dummy plate **501** so that a sealing cover glass **200** having a spacer is formed as shown in FIG. 20C.

According to such a structure, the adhesive layer **402** is only softened by heating during division so that the dummy plate **401** can be removed readily and the division can be carried out very easily.

The bonding and isolating steps are the same as those described in the seventh to ninth embodiments.

Eighteenth Embodiment

Next, an eighteenth embodiment of the invention will be described.

While the description has been given to the example in which the spacer is formed on the translucent substrate in the first to seventeenth embodiments, there will be described an example in which a spacer is formed on the IT-CCD substrate side in the following eighteenth to twenty-second embodiments.

In this example, a spacer **106S** is formed integrally with a silicon substrate **101** constituting the IT-CCD substrate. Other portions are formed in the same manner as those in the embodiments.

First of all, a resist pattern is formed on the surface of the silicon substrate **101** by photolithography as shown in FIG. 21A and a concave portion **105** is formed using the resist pattern as a mask by selective etching so that the spacer **106S** is formed as shown in FIG. 21B.

As shown in FIG. 21C, then, a channel stopper layer is formed, a channel region is formed and an element region such as an electric charge transfer electrode . . . is formed in an element formation region surrounded by the spacer **106S** by using an ordinary silicon process. Moreover, there is formed

32

a bonding pad BP which is provided with a wiring layer on a surface and comprises a gold layer for an external connection.

Thereafter, a glass substrate **201** provided with a trench section **204** is prepared as shown in FIG. 21D and an alignment is carried out opposite to the element formation surface of the IT-CCD substrate **100** and the glass substrate **201** is integrated as shown in FIG. 21E. The integration is firmly carried out by heating an adhesive layer **107** applied to the surface of the spacer **106S**.

As shown in FIG. 21F, finally, the glass substrate side and the IT-CCD substrate side are thinned by CMP so that isolation into the IT-CCDs can be carried out. The thinning step is not restricted to the CMP but can be executed by grinding, polishing or etching.

In the case in which the trench section **204** is not formed on the glass substrate, moreover, cutting is carried out through dicing or laser so that the isolation can be performed with a high workability. In the case in which a cut trench **104** is not formed on the silicon substrate **101**, furthermore, the cutting is carried out by using a diamond blade so that the isolation can be performed with a high workability.

According to this method, the spacer is formed integrally with the IT-CCD substrate. Therefore, it is possible to form a solid-state imaging device having a high reliability without generating a strain in a bonded portion.

Nineteenth Embodiment

Next, a nineteenth embodiment of the invention will be described.

While the description has been given to the example in which the spacer is formed integrally with the IT-CCD substrate in the eighteenth embodiment, a silicon substrate **108** may be stuck onto the IT-CCD substrate through an adhesive layer **107** so as to be subjected to patterning on the IT-CCD substrate in this example. Other portions are formed in the same manner as those in the eighteenth embodiment.

More specifically, first of all, a channel stopper layer is formed, a channel region is formed and an element region such as an electric charge transfer electrode . . . is formed on a silicon substrate **101** by using an ordinary silicon process as shown in FIGS. 22A to 22C in this example. Moreover, there is formed a bonding pad BP which is provided with a wiring layer on a surface and comprises a gold layer for an external connection.

As shown in FIG. 22A, then, a silicon substrate **103** is stuck onto the IT-CCD substrate through the adhesive layer **107**.

As shown in FIG. 22B, thereafter, the silicon substrate **103** is selectively removed from the IT-CCD substrate by an etching method using photolithography to form a spacer **103S**.

As shown in FIG. 22C, subsequently, an adhesive layer **109** is applied onto the spacer **103S** and a cut trench **104** is formed.

According to this method, the spacer is provided after the formation of the element region on the silicon substrate. Therefore, the spacer is not an obstacle in the formation of the element region and manufacture can easily be carried out. Since integral formation is not performed, there is also a problem in that a slight strain cannot be avoided.

The bonding and isolating steps are the same as those described in the embodiments.

Twentieth Embodiment

Next, a twentieth embodiment of the invention will be described.

While the description has been given to the example in which the silicon substrate **108** is stuck onto the IT-CCD substrate through the adhesive layer **107** and is etched over the IT-CCD substrate to form the spacer **103S** in the nineteenth embodiment, a dummy substrate **601** may be used to

form the spacer **103S** thereon and may be stuck to a silicon substrate **101** provided with an IT-CCD, that is, a substrate for the formation of the IT-CCD. Other portions are formed in the same manner as those in the nineteenth embodiment.

More specifically, as shown in FIG. **23A**, a silicon substrate **103** to be the spacer is stuck to the dummy plate **601** formed by a silicon substrate through an adhesive layer **602** having a softening temperature of approximately 50 to 150 degree C. Then, the silicon substrate **103** is selectively removed by an etching method using photolithography, thereby forming the spacer **103S**.

As shown in FIG. **23B**, then, the silicon substrate **101** provided with the IT-CCD is stuck to the spacer **103S** side through an adhesive layer **202** having a softening temperature of approximately 100 to 200 degree C.

Thus, the silicon substrate **201** provided with the IT-CCD is stuck and heating is then carried out to approximately 50 to 150 degree C. to soften the adhesive layer **602**, thereby removing the dummy plate **601** as shown in FIG. **23C**. As shown in FIG. **23D**, subsequently, a cut trench **104** is formed so that an IT-CCD substrate **100** having a spacer is formed in the same manner as in FIG. **22B**.

The bonding and isolating steps for the glass substrate and the IT-CCD substrate are the same as those described in the eighteenth embodiment.

According to such a method, it is not necessary to process the spacer over the IT-CCD substrate. Consequently, it is possible to prevent a scratch from being made on the IT-CCD substrate, thereby deteriorating a yield.

While the cut trench **104** is provided after the formation of the spacer in the embodiment, it is apparent that the cut trench **104** may be provided before the formation of the spacer.

In the embodiments, the bonding of the glass substrate and the space and the bonding of the silicon substrate constituting the IT-CCD and the spacer are carried out by using the adhesive layer. It is possible to obtain firm bonding by carrying out surface activation and performing the bonding through cold direct bonding.

While the silicon substrate is used for the spacer in the first to twentieth embodiments (excluding the eleventh, twelfth and fifteenth embodiments), it is not restricted but a 42-alloy having a coefficient of thermal expansion which is almost equal to that of the IT-CCD substrate can also be applied. Furthermore, it is also possible to use a material having a coefficient of thermal expansion which is almost equal to that of a translucent substrate. In addition, a polyimide resin may be used. In this case, a flexibility can be obtained and an effect of absorbing a strain can also be produced for the generation of the strain due to a change in a temperature.

Furthermore, the spacer may be formed by using an adhesive tape. In this case, it is possible to carry out a processing with high precision by cutting using a laser processing after sticking to a whole surface.

In addition, while the silicon substrate or the glass substrate is used for the dummy plate in the first to twentieth embodiments, it is not restricted but a metal plate can also be used. Furthermore, a flexible film may be used.

Moreover, it is also possible to apply a semi-curing resin, a UV curing resin, an UV/thermosetting combination type resin and a thermosetting resin for the adhesive layer.

In addition, it is possible to properly select a transfer method, screen printing or a dispense method for a method of forming the adhesive layer.

While the cut trench is provided prior to the formation of the spacer in the eighteenth to twentieth embodiments, it is apparent that the cut trench may be provided after the formation of the spacer.

Next, description will be given to a solid-state imaging device comprising a reinforcing plate according to a twenty-first embodiment of the invention.

As shown in FIG. **24**, the solid-state imaging device is characterized in that a reinforcing plate **701** formed by a silicon substrate bonded through a silicon oxide film (not shown) is stuck to the back side of a silicon substrate **101** constituting an IT-CCD substrate **100** of the solid-state imaging device according to the first embodiment. Herein, the reinforcing plate **701** formed by the silicon substrate having the silicon oxide film formed on a surface is bonded onto the IT-CCD substrate by direct bonding using surface activating cold bonding.

The structure of the element is the same as that of the solid-state imaging device described in the first embodiment, and the silicon substrate is thinned to have an almost half thickness from the back face by a CMP method and the reinforcing plate **701** is bonded to the back face as shown in FIG. **24** in order to compensate for a reduction in a strength which is caused by the thinning.

According to such a structure, the IT-CCD substrate **100** can be thinned to increase a driving speed and a reduction in a strength which is caused by the thinning can be compensated by the reinforcing plate. Moreover, a moisture resistance can also be enhanced.

Next, description will be given to a process for manufacturing the solid-state imaging device.

A processing to be carried out till the step of sticking a glass substrate to the IT-CCD substrate is basically the same as that of the first embodiment. More specifically, as shown in FIG. **25A**, an element region constituting the IT-CCD is formed by using an ordinary silicon process on the silicon substrate **101** provided with a cut trench **104** in advance, and furthermore, there is formed a bonding pad BP which is provided with a wiring layer on a surface and comprises a gold layer for an external connection.

As shown in FIG. **25B**, then, an alignment is carried out with an alignment mark formed in the peripheral edge portion of each substrate, and a sealing cover glass **200** is mounted on the IT-CCD substrate **100** provided with an element region as described above and heating is carried out to integrate both of them with an adhesive layer **202**. This process may employ surface activating cold bonding.

As shown in FIG. **25C**, thereafter, the glass substrate is maintained as it is and the CMP method is carried out from the back side of the silicon substrate **101** in the same manner to polish the cut trench **104** portion. Thus, isolation into individual solid-state imaging devices can be carried out.

As shown in FIG. **25D**, furthermore, the reinforcing plate **701** formed by a silicon substrate having a silicon oxide film (not shown) provided on a surface is bonded to the back side of the thinned silicon substrate **101** by direct bonding using the surface activating cold bonding.

Finally, the back side of a glass substrate **201** is removed to reach the trench section **204**, and the glass substrate is thinned and is individually isolated at the same time. In the end, the reinforcing plate **701** is subjected to dicing by using a diamond blade (a grindstone), thereby forming a solid-state imaging device having a reinforcing plate as shown in FIG. **25E**.

Thus, the solid-state imaging device can be formed very easily.

According to the method of the invention, consequently, collective mounting is carried out and individual isolation is then performed without the execution of an individual align-

ment and an electrical connection such as wire bonding. Therefore, manufacture can easily be carried out and handling can also be performed readily. Moreover, the silicon substrate is first thinned and isolated and the reinforcing plate is stuck and is then subjected to the dicing. Consequently, a high reliability can be obtained.

While the spacer is formed on the glass substrate in the embodiment, it is also possible to apply a spacer which is provided on the IT-CCD substrate or is provided separately.

While the reinforcing plate is constituted by the silicon substrate isolated from the IT-CCD substrate and is caused to have an adiabatic property in the embodiment, moreover, it is also possible to utilize a substrate having an excellent heat conductiveness for a radiation plate. According to the embodiment, furthermore, a moisture resistance can also be enhanced. In addition, also in the case in which the cut trench **104** is not provided, the embodiment can be applied.

Twenty-second Embodiment

As a twenty-second embodiment of the invention, moreover, it is also possible to obtain a shield plate **801** by sticking a metal substrate such as tungsten or chromium in place of the reinforcing plate as shown in FIG. **26**. Other portions are constituted in just the same manner.

According to such a structure, an electromagnetic wave can be shielded so that an unnecessary radiation noise can be reduced.

Twenty-third Embodiment

Next, a twenty-third embodiment of the invention will be described.

In the first to twenty-second embodiments, the bonding pad formed on the surface of the IT-CCD substrate is formed to be exposed and the edge of the translucent substrate (glass substrate) **201** is formed to be placed on the inside of the edge of the IT-CCD substrate in such a manner that an electrical connection can be carried out over the surface of the IT-CCD substrate. This example is characterized in that the edges of an IT-CCD substrate and a glass substrate are constituted equally and the back side is fetched via a through hole H penetrating through an IT-CCD substrate **100** and a reinforcing plate **701** stuck to a back face thereof as shown in FIG. **27C**. **108** denotes a conductor layer and **109** denotes a silicon oxide layer to be an insulating layer. More specifically, a glass substrate **201** to be a translucent member is bonded to the surface of the IT-CCD substrate **100** comprising a silicon substrate **101** to be a semiconductor substrate provided with an IT-CCD **102** through a spacer **S203** in order to have a gap C corresponding to the light receiving region of the silicon substrate **101**, and furthermore, a pad **113** and a bump **114** are formed to be external fetch terminals which are formed on the back side of the IT-CCD substrate **100** via the through hole H formed on the silicon substrate **101**, and the edge is individually isolated by dicing and an external connection is carried out through the bump **114**. As shown in FIG. **28D**, a connection to a peripheral circuit board **901** is carried out through an anisotropic conductive film **115**. In addition, diffusion bonding using an ultrasonic wave, solder bonding and eutectic bonding by thermocompression are effective. Furthermore, a clearance may be underfilled with a resin. The spacer **203S** has a height of 30 to 150 μm , and preferably 80 to 120 μm . Other portions are formed in the same manner as those in the first embodiment.

A process for manufacturing the solid-state imaging device is shown in FIGS. **27A** to **27C** and FIGS. **28A** to **28D**.

More specifically, in this method, the reinforcing plate **701** formed by a silicon substrate provided with a silicon oxide film (not shown) is bonded, through surface activating cold bonding, to the back face of the IT-CCD substrate **100** provided with an element region for the formation of an IT-CCD and a bonding pad BP for an external connection by using an ordinary silicon process in the same manner as in the steps shown in FIGS. **6A** and **6B** in the fourth embodiment (FIG. **27A**).

As shown in FIG. **27B**, then, an alignment is carried out with an alignment mark formed in the peripheral edge portion of each substrate, and a cover glass **200** having the spacer **203S** bonded to the plate-shaped glass substrate **201** is mounted on the IT-CCD substrate **100** formed as described above and is thus heated so that both of them are integrated with an adhesive layer **207**.

A through hole is formed on the back side of the reinforcing plate **701** by an etching method using photolithography. Then, a silicon oxide film **109** is formed in the through hole by a CVD method. Thereafter, anisotropic etching such as RIE or ICP dry etching is carried out to cause the silicon oxide film **109** to remain on only the side wall of the through hole and the bonding pad BP is exposed as shown in FIG. **27C**.

As shown in FIG. **28A**, subsequently, a tungsten film is formed as the conductor layer **108** to come in contact with the bonding pad in the through hole by a CVD method using WF_6 .

As shown in FIG. **28B**, then, the bonding pad **113** and the bump **114** are formed on the surface of the reinforcing plate **701**.

Thus, it is possible to form a signal fetch electrode terminal and a conducting electrode terminal on the reinforcing plate **701** side.

As shown in FIG. **28C**, thereafter, an anisotropic conductive film **115** (ACP) is applied onto the surface of the reinforcing plate **701**.

As shown in FIG. **28D**, finally, the circuit board **901** provided with a driving circuit is connected through the anisotropic conductive film **115**. The circuit board **901** is provided with a contact layer **117** formed by a conductor layer filled in the through hole to penetrate through the board and a bonding pad **118**.

Accordingly, it is possible to easily achieve a connection to a circuit board such as a printed board through the bonding pad **118**. Moreover, the contact layer **117** is formed in alignment with the conductor layer **108** formed on the IT-CCD substrate.

Then, the whole device is subjected to dicing along a dicing line DC and division into individual solid-state imaging devices is carried out (only one unit is shown in the drawing and a plurality of IT-CCDs are continuously formed on one wafer).

Thus, the solid-state imaging device can be formed very easily with a high workability.

The reinforcing plate **701** is constituted by the silicon substrate provided with the silicon oxide film. Therefore, it is possible to carry out heat insulation or electrical insulation from the IT-CCD substrate **100**.

While the conductor layer is formed in the through hole by the CVD method in the embodiment, moreover, it is possible to easily fill the conductive layer in the contact hole having a high aspect ratio with a high workability by using a plating method, a vacuum screen printing method or a vacuum sucking method.

While the electrical connection of the surface and back of the IT-CCD substrate and the circuit board mounting the peripheral circuit is carried out by using the through hole in

37

the embodiments, furthermore, it is not restricted but a method of forming a contact to electrically connect the surface and the back by impurity diffusion from the surface and the back face can also be employed.

Thus, it is possible to form the signal fetch electrode terminal and the conducting electrode terminal on the reinforcing plate **701** side.

Twenty-fourth Embodiment

Next, a twenty-fourth embodiment of the invention will be described.

While the through hole is formed to penetrate through the reinforcing plate **701** and the conductor layer **111** is formed in the twenty-third embodiment, an IT-CCD substrate is formed by using a silicon substrate provided with a hole (a vertical hole) in advance in the embodiment. Since a small formation depth for the vertical hole is enough, consequently, a productivity can be enhanced and a manufacturing yield can be improved. Other portions are formed in the same manner as those of the twenty-third embodiment.

More specifically, as shown in FIG. **29A**, a resist pattern is first formed on the back face of the silicon substrate by photolithography prior to the formation of an IT-CCD, and a vertical hole **118** is formed by RIE (reactive ion etching) by using the resist pattern as a mask. At this step, a pad **110** formed of aluminum is provided on a surface and the vertical hole **118** is formed to reach the pad **110**.

As shown in FIG. **29B**, then, a silicon oxide film **119** is formed on the internal wall of the vertical hole **118** by a CVD method.

As shown in FIG. **29C**, an element region for forming the IT-CCD is provided by using the same ordinary silicon process as that of each of the embodiments.

As shown in FIG. **29D**, then, an alignment is carried out with an alignment mark formed in the peripheral edge portion of each substrate, and a cover glass **200** having a spacer **203S** bonded to a plate-shaped glass substrate **201** is mounted on an IT-CCD substrate **100** formed as described above and is thus heated so that both of them are integrated with an adhesive layer **207**. Similarly, surface activating cold bonding may be used at the bonding step.

As shown in FIG. **29E**, thereafter, the reinforcing plate **701** is bonded to the back side of the IT-CCD substrate **100** through the surface activating cold bonding and a through hole **108** is formed to reach the vertical hole **118** from the back side by an etching method using photolithography. Similarly, it is desirable that the internal wall of the through hole should be insulated. Moreover, it is also possible to use a reinforcing plate provided with a through hole in advance.

Subsequently, the steps shown in FIGS. **28A** to **28D** described in the twenty-third embodiment are executed. Consequently, it is possible to easily form a solid-state imaging device having such a structure that a circuit board provided with a peripheral circuit is laminated.

In the embodiment, as described above, a productivity can be enhanced because of the small formation depth of the vertical hole and a manufacturing yield can be improved.

Twenty-fifth Embodiment

Next, a twenty-fifth embodiment of the invention will be described.

In the twenty-fourth embodiment, the contact is formed to penetrate through the reinforcing plate **701**, the IT-CCD substrate and the circuit board and an electrode is fetched from the circuit board side. The embodiment is characterized in

38

that a conductor layer **120** to be a wiring layer is formed on a side wall and an electrode is fetched from the side wall of the solid-state imaging device as shown in FIGS. **30A** and **30B**. Other portions are formed in the same manner as those of the twenty-fourth embodiment.

A manufacturing process is almost the same as that of the twenty-fourth embodiment. The position of a through hole is caused to correspond to each of the ends of the solid-state imaging devices and dicing is carried out by using a cutting line DC including the through hole. Consequently, it is possible to easily form a solid-state imaging device having a wiring layer formed on a side wall.

Moreover, the conductor layer **120** to be filled in the through hole is constituted by a shielding material such as tungsten. Consequently, although the solid-state imaging device is not completely shielded, a malfunction can be reduced.

When the reinforcing plate is constituted by a polyimide resin, ceramic, a crystallized glass or a silicon substrate having a surface and a back face oxidized if necessary, it can function as an adiabatic substrate. Moreover, the reinforcing plate may be formed by a shielding material.

Twenty-sixth Embodiment

Next, a twenty-sixth embodiment of the invention will be described.

While the back side of the IT-CCD substrate **100** is provided on the peripheral circuit board through the reinforcing plate as shown in FIG. **28** in the twenty-third and twenty-fourth embodiments, the IT-CCD substrate **100** is provided on a peripheral circuit board **901** and a reinforcing plate **701** is sequentially provided on the back side of the peripheral circuit board **901** as shown in FIG. **31** in this example. Other portions are formed in the same manner as those of the twenty-fourth or twenty-fifth embodiment.

The reinforcing plate also serves as a radiation plate.

While a manufacturing process is almost the same as that of each of the twenty-third and twenty-fourth embodiments, the IT-CCD substrate **100** and the peripheral circuit board **901** are provided close to each other. Correspondingly, a connecting resistance can be reduced and high-speed driving can be carried out.

Twenty-seventh Embodiment

Next, a twenty-seventh embodiment of the invention will be described.

While the through hole is formed in the substrate and the electrode is fetched from the back side of the peripheral circuit board in the twenty-sixth embodiment, this example is characterized in that a conductor layer **120** to be a wiring layer is formed on a side wall through an insulating film **121** as shown in FIG. **32**. Other portions are formed in the same manner as those of the twenty-sixth embodiment.

Manufacture is almost the same as that of the twenty-fifth embodiment. By only setting a dicing line into a position including a contact formed on a through hole, it is possible to easily form a solid-state imaging device having a side wall wiring.

In the solid-state imaging device, the wiring is formed on the side wall. Therefore, it is possible to form a signal fetch terminal and a current supply terminal on the side wall. It is apparent that a pad and a bump on the back side of a peripheral circuit board **901** may be formed to carry out a connection. **701** denotes a reinforcing plate.

In the twenty-first to twenty-seventh embodiments, a sealing cover glass **200** can be formed in the same manufacturing method as that of each of the first to twentieth embodiments.

Twenty-eighth Embodiment

Next, a twenty-eighth embodiment of the invention will be described.

In the twenty-third embodiment, the through hole is formed in the substrate and the electrode is fetched on the back side of the peripheral circuit board. This example is characterized in that a conductor layer **209** is formed in a through hole **208** provided through a glass substrate **201** and a spacer **203S** and a pad **210** is formed on the upper surface of the glass substrate **201**, and a signal fetch terminal and a current supply terminal are formed thereon. Other portions are formed in the same manner as those in the twenty-third embodiment shown in FIGS. **27** and **28**.

Next, a process for manufacturing a solid-state imaging device is shown in FIGS. **34A**, **34A'**, and **34B** to **34F** and FIGS. **35A** to **35E**.

More specifically, in the twenty-third embodiment, the through hole is formed on the IT-CCD substrate **100** and the signal fetch terminal and the current supply terminal are formed on the back side of the IT-CCD substrate **100** at the step shown in FIG. **27C**. On the other hand, this method is characterized in that the spacer **203S** is stuck to the glass substrate **201** constituting a sealing cover glass **200** and the through hole **208** is formed to penetrate through the spacer **203S** and the glass substrate **201** in that state, and the conductor layer is formed therein and the signal fetch terminal and the current supply terminal are formed on the surface side of the sealing cover glass **200**.

First of all, as shown in FIG. **34A**, a silicon substrate **203** having a thickness of 30 to 120 μm for forming the spacer is prepared.

As shown in FIG. **34A'**, next, the glass substrate **201** for constituting the sealing cover glass **200** is prepared.

As shown in FIG. **34B**, then, an adhesive layer **202** is applied onto the surface of the substrate **203**.

As shown in FIG. **34C**, thereafter, the silicon substrate **203** having the adhesive layer **202** applied thereto is stuck to the surface of the glass substrate **201**.

As shown in FIG. **34D**, subsequently, a resist pattern is formed by photolithography and RIE (reactive ion etching) is carried out by using the resist pattern as a mask, and an adhesive is previously applied to remove a concave portion **205** including a region corresponding to a photodiode, that is, a region corresponding to a light receiving region (**40** in FIG. **1B**) or a removal processing is carried out by an oxygen plasma after the RIE.

As shown in FIG. **34E**, then, a resist pattern is formed by the photolithography and the RIE (reactive ion etching) is carried out by using the resist pattern as a mask. Consequently, the through hole **208** is formed to penetrate through the spacer **203S** and the glass substrate **201**.

Thereafter, a silicon oxide film (not shown) is provided on at least the internal wall of the spacer formed of silicon by CVD if necessary.

In the case in which the spacer is formed by an insulator such as a glass or a resin, this step is not required. Moreover, a shielding film may be formed on the internal or external wall of the spacer.

As shown in FIG. **35A**, thereafter, the conductor layer **209** is formed on the internal wall of the through hole which is insulated by vacuum screen printing or metal plating using a conductive paste such as a silver paste or a copper paste, and a through contact region penetrating through the spacer **203S** and the glass substrate **201** is formed.

As shown in FIG. **35B**, subsequently, gold bonding pads **210** and **211** or a bump **212** are/is formed on the surface and back face of the glass substrate having the spacer so as to be connected to the through contact region. In the film formation, a thin gold film is formed on the surface and the back face and patterning is carried out by an etching method using photolithography, or screen printing or selective plating can be applied.

Furthermore, an anisotropic conductive resin film **213** is applied as shown in FIG. **35C**.

On the other hand, as shown in FIG. **35D**, the IT-CCD substrate **100** provided with a reinforcing plate **701** is prepared in the same manner as in the twenty-third embodiment.

As shown in FIG. **35E**, then, an alignment is carried out with an alignment mark formed in the peripheral edge portion of each substrate, and the cover glass **200** having the spacer **203S** bonded to the plate-shaped glass substrate **201** is mounted on the IT-CCD substrate **100** formed as described above and is thus heated so that both of them are integrated with the anisotropic conductive film **213**.

Then, the whole device is subjected to dicing along a dicing line DC and division into individual solid-state imaging devices is carried out.

Thus, the solid-state imaging device provided with a contact region such as a bonding pad on a sealing cover glass can be formed very easily with a high workability.

Twenty-ninth Embodiment

Next, a twenty-ninth embodiment of the invention will be described.

While the description has been given to the solid-state imaging device in which the through hole penetrating through the glass substrate and the spacer is formed and the contact region such as a bonding pad is formed on the sealing cover glass in the twenty-eighth embodiment, a variant will be described in the following thirtieth to thirty-third embodiments.

First of all, the embodiment is characterized by the formation of a through hole on a spacer, and a glass substrate **201** is prepared as shown in FIG. **36A**.

As shown in FIG. **36B**, a photosetting resin is formed on the surface of the glass substrate **201** by a photoshielding method so that a spacer **213** is formed.

As shown in FIG. **36C**, then, a through hole **208** is formed by an etching method using photolithography.

Thus, it is possible to easily obtain a sealing cover glass which has the spacer and is provided with the through hole.

Subsequently, the mounting steps shown in FIGS. **35A** to **35E** are executed in the same manner as described in the twenty-eighth embodiment, and sticking to an IT-CCD substrate is carried out to perform dicing. Consequently, the solid-state imaging device shown in FIG. **35E** can be obtained.

According to such a method, the spacer can easily be formed. While the photosetting resin is used in the embodiment, an adhesive itself may be used. The glass substrate and the spacer are formed integrally and a warpage and a strain can be reduced, and furthermore, manufacture can also be carried out easily.

Thirtieth Embodiment

Next, a thirtieth embodiment of the invention will be described.

While the silicon substrate for forming the spacer is stuck to the glass substrate and is subjected to the patterning in the twenty-eighth embodiment, a glass substrate may be etched at a one-time etching step to form a concave portion and a

through hole at the same time in the embodiment. Other portions are formed in the same manner as those of the twenty-eighth embodiment.

In the embodiment, first of all, a glass substrate **201** is prepared as shown in FIG. **37A**.

As shown in FIG. **37B**, then, a resist pattern **R** is formed on the surface and back face of the glass substrate **201**, an opening is provided on both of the surface and back face in a region in which a through hole is to be formed and an opening is provided on only the back side in a region in which a concave portion **205** (and a cut trench **204** if necessary) is/are to be formed.

As shown in FIG. **37C**, thereafter, the glass substrate is etched from both surfaces by using, as masks, the resist patterns on the surface and back face so that the concave portion **205**, a cut trench (not shown) and a through hole **208** are formed at the same time.

Thus, it is possible to easily obtain a sealing cover glass having a spacer formed integrally therewith and a through hole formed therein.

Subsequently, the mounting steps shown in FIGS. **35A** to **35E** are executed in the same manner as described in the twenty-eighth embodiment, and sticking to an IT-CCD substrate is carried out to perform dicing. Consequently, the solid-state imaging device shown in FIG. **35E** can be obtained.

The glass substrate and the spacer are formed integrally and a warpage and a strain can be reduced, and furthermore, manufacture can also be carried out easily.

Thirty-first Embodiment

Next, a thirty-first embodiment of the invention will be described.

While the silicon substrate for forming a spacer is stuck to the glass substrate and is subjected to the patterning in the twenty-eighth embodiment, a spacer **203S** having a pattern formed thereon is stuck to a glass substrate **201** and a through hole is finally formed at an etching step in the embodiment. Other portions are formed in the same manner as those of the twenty-eighth embodiment.

First of all, in the embodiment, the glass substrate **201** is prepared as shown in FIG. **38A**.

On the other hand, a silicon substrate **203** for forming a spacer is prepared as shown in FIG. **38A'**.

As shown in FIG. **38B**, then, the silicon substrate **203** is processed by an etching method using photolithography so that the spacer **203S** is obtained.

As shown in FIG. **38C**, thereafter, an adhesive **202** is applied onto the surface of the spacer **203S** subjected to the patterning.

As shown in FIG. **38D**, subsequently, the spacer **203S** is stuck in alignment with the glass substrate **201**.

As shown in FIG. **38E**, then, a through hole **208** is formed by the etching method using the photolithography.

Thus, it is possible to easily obtain a sealing cover glass which has the spacer stuck thereto and the through hole formed thereon.

Thereafter, a silicon oxide film (not shown) is provided on at least the internal wall of the spacer formed of silicon by CVD if necessary.

In the case in which the spacer is formed by an insulator such as a glass or a resin, this step is not required. Moreover, a shielding film may be formed on the internal or external wall of the spacer.

Subsequently, the mounting steps shown in FIGS. **35A** to **35E** are executed in the same manner as described in the

twenty-eighth embodiment, and sticking to an IT-CCD substrate is carried out to perform dicing. Consequently, the solid-state imaging device shown in FIG. **35E** can be obtained.

It is also possible to stick the glass substrate to the spacer by using an ultraviolet curing resin, a thermosetting resin or both of them or applying a semicuring adhesive. In the formation of the adhesive, moreover, it is possible to properly select supply using a dispenser, screen printing or stamp transfer.

As shown in FIG. **38C**, moreover, it is also possible to form a shielding film **215** by a method of sputtering a tungsten film into the inside wall of the concave portion of the spacer.

Consequently, it is possible to obtain an excellent image pick-up characteristic without separately providing the shielding film.

Thirty-second Embodiment

Next, a thirty-second embodiment of the invention will be described.

In the twenty-eighth embodiment, the description has been given to the example in which the silicon substrate for forming a spacer is stuck to the glass substrate and is patterned, and the through hole to penetrate through the glass substrate and the spacer is finally formed by etching. In the embodiment, as shown in FIGS. **39A** to **39F**, a shape processing is carried out by etching a silicon substrate, and a spacer **203S** formed up to a through hole **208a** shown in FIG. **39E** and a glass substrate **201** provided with a through hole **208b** shown in FIG. **39B'** are aligned by using an alignment mark on a wafer level and both of them are stuck together with an adhesive layer **202**. Other portions are formed in the same manner as those in the twenty-eighth embodiment.

Also in this case, it is also possible to form a shielding film (**215**) on an inside wall facing the concave portion of the spacer.

According to such a method, since the through holes are individually formed to carry out the sticking, the alignment is required and an almost half aspect ratio is enough. Consequently, the through hole can easily be formed.

Subsequently, the mounting steps shown in FIGS. **35A** to **35E** are executed in the same manner as described in the twenty-eighth embodiment, and sticking to an IT-CCD substrate is carried out to perform dicing. Consequently, the solid-state imaging device shown in FIG. **35E** can be obtained.

Thirty-third Embodiment

Next, a thirty-third embodiment of the invention will be described.

In the twenty-eighth embodiment, the silicon substrate for forming a spacer is stuck to the glass substrate and the conductor layer **209** is formed in the through hole penetrating through the glass substrate and the spacer at the etching step and the IT-CCD substrate **100** is then stuck thereto. The embodiment is characterized in that a glass substrate **200** having a spacer which is provided with a through hole **208** in the twenty-eighth to thirty-second embodiments is aligned with the IT-CCD substrate **100** having a reinforcing plate **701** stuck to a back face on a wafer level and they are stuck together, and the conductor layer **209** is then formed in the through hole **208** as shown in FIGS. **40A** to **40D**. Moreover, a bonding pad **210** is formed to be connected to the conductor layer **209**. Other portions are formed in the same manner as those in the twenty-eighth embodiment.

43

When the conductor layer **209** is to be filled, similarly, it is possible to easily carry out the formation by vacuum screen printing using a conductive paste such as a copper paste or metal plating.

Thirty-fourth Embodiment

Next, a thirty-fourth embodiment of the invention will be described.

While the sealing cover glass formed of a plate-shaped member is used for the translucent member in the first to thirty-third embodiments, the sealing cover glass itself is caused to have an image forming function to constitute an optical member so that a size can be more reduced.

As shown in FIG. **41**, a solid-state imaging device is characterized in that a sealing cover glass **220** having a lens array is used in place of the sealing cover glass **200** according to the twenty-eighth to thirty-third embodiments.

The sealing cover glass **220** is formed by a shielding method or an etching method.

Moreover, other portions are formed in almost the same manner as those in the twenty-eighth embodiment.

In the twenty-eighth embodiment, as shown in FIG. **33**, the conductor layer **209** is formed in the through hole **208** provided in the glass substrate **201** and the spacer **203S**, and furthermore, the pad **210** is formed on the upper surface of the glass substrate **201** and the signal fetch terminal and the current supply terminal are formed thereon. This example is characterized in that a bonding pad BP is connected to an external connecting terminal in a partial region which is not shown and a signal fetch terminal and a current supply terminal are constituted. Other portions are formed in the same manner as those in the twenty-eighth embodiment shown in FIGS. **33** and **34**.

Next, a process for manufacturing the solid-state imaging device is shown in FIGS. **42A** to **42D** and FIGS. **43A** to **43C**.

More specifically, the manufacturing process is also varied greatly in that the sealing cover glass **220** having a lens array is used in place of the sealing cover glass **200** according to the twenty-eighth to thirty-third embodiments.

Moreover, while the spacer **203S** is stuck to the glass substrate **201** constituting the sealing cover glass **200**, and the through hole **208** is formed to penetrate through the spacer **203S** and the glass substrate **201** in that state and the conductor layer is formed therein, and the signal fetch terminal and the current supply terminal are formed on the surface side of the sealing cover glass in the thirty-third embodiment, the formation may be carried out in the same manner in this example.

An adhesive layer **207** is formed on the surface of the spacer **203S** of the sealing cover glass **220** having a lens array which is provided at steps shown in FIGS. **42A** to **42D** (which is shown in FIG. **43A**).

On the other hand, an IT-CCD substrate **100** provided with a reinforcing plate **701** is prepared as shown in FIG. **43B** in the same manner as that used in the twenty-eighth embodiment.

As shown in FIG. **43C**, then, an alignment is carried out with an alignment mark formed in the peripheral edge portion of each substrate, and the cover glass **220** having a lens array to which the spacer **203S** is stuck is mounted on the IT-CCD substrate **100** formed as described above and is thus heated so that both of them are integrated with the adhesive layer **207**.

Moreover, a variant of a process for manufacturing the sealing cover glass **220** having a spacer will be described in thirty-fifth to thirty-eighth embodiments.

44

Thirty-fifth Embodiment

Next, a thirty-fifth embodiment of the invention will be described.

As shown in FIGS. **44A** and **44B**, the embodiment is characterized in that a sealing cover glass **220** having a lens array is prepared and a concave portion **225** is formed on the back side thereof by etching, and a spacer **223S** is formed integrally. Other portions are formed in the same manner as those in the embodiments.

According to such a structure, the formation can easily be carried out with a high workability, and furthermore, it is possible to obtain the sealing cover glass **220** having a lens array in which a strain is not generated because of the integral formation and a reliability is enhanced.

Thirty-sixth Embodiment

Next, a thirty-sixth embodiment of the invention will be described.

In the embodiment, first of all, a glass substrate **220** having a lens array is prepared as shown in FIG. **45A**.

As shown in FIG. **45B**, then, a photocuring resin is formed on the surface of the glass substrate **220** having a lens array by a photoshielding method and a spacer **223S** is formed.

Thus, it is possible to easily obtain a sealing cover glass which has the spacer and is provided with a through hole.

Subsequently, the mounting steps shown in FIGS. **43A** to **43C** are executed in the same manner as described in the thirty-fourth embodiment, and sticking to an IT-CCD substrate is carried out to perform dicing. Consequently, the solid-state imaging device shown in FIG. **43C** can be obtained.

Thirty-seventh Embodiment

Next, a thirty-seventh embodiment of the invention will be described.

In the thirty-fourth embodiment, as shown in FIGS. **46A** to **46D**, a spacer **203S** formed by an etching method may be stuck to a sealing cover glass **220** having a lens array. At the mounting step, sticking to an IT-CCD substrate is carried out to perform dicing in the same manner as in the thirty-sixth embodiment. Consequently, a solid-state imaging device can be obtained.

Thirty-eighth Embodiment

Next, a thirty-eighth embodiment of the invention will be described.

As shown in FIG. **47**, moreover, a sealing cover glass **220** having a lens array, a spacer **203S** and an IT-CCD substrate **100** having a reinforcing plate **701** may be fixed at the same time.

Thirty-ninth Embodiment

Next, a thirty-ninth embodiment of the invention will be described.

As shown in FIGS. **48A** to **48D**, moreover, a sealing cover glass **220** having a lens array can also be applied to the solid-state imaging device in which the peripheral circuit board **901** is provided through the anisotropic conductive film **115** shown in FIGS. **28A** to **28D** in the twenty-third embodiment. Other portions are formed in the same manner as those in the embodiments.

45

Also in the connection of the peripheral circuit board **901**, furthermore, diffusion bonding using an ultrasonic wave, solder bonding and eutectic bonding by thermocompression are also effective. In addition, underfilling using a resin may be carried out.

The sealing cover glass **220** having a lens array may be used in place of the sealing cover glass **200** formed by a plate-shaped member.

Fortieth Embodiment

Next, a fortieth embodiment of the invention will be described.

As shown in FIG. **49**, moreover, the IT-CCD substrate **100**, the peripheral circuit board **901** and the reinforcing plate **701** may be provided in this order as shown in FIG. **31** in the twenty-sixth embodiment. Other portions are formed in the same manner as those in the embodiments.

Forty-first Embodiment

Next, a forty-first embodiment of the invention will be described.

As shown in FIG. **50**, moreover, it is also effective that a wiring **221** is formed on the side wall of a spacer.

Manufacture is carried out in the same manner as that in the twenty-seventh embodiment and it is possible to easily form the wiring on the side wall by providing a through hole in the spacer, forming a conductor layer in the through hole, sticking an IT-CCD substrate to a sealing cover glass **220** having a lens and then carrying out division along a dicing line including the through hole. Other portions are formed in the same manner as those in the embodiments.

While the description has been given to the method of carrying out, with an adhesive layer or with an anodic bonding, the bonding of a glass substrate constituting a sealing cover glass to a spacer and the bonding of an IT-CCD substrate to the sealing cover glass or the method employing the anode bonding or the surface activating cold bonding in the embodiments, it is also possible to properly carry out the bonding through the surface activating cold bonding without using an adhesive in the case in which the spacer and the surface of the IT-CCD substrate is formed of Si or metal in all of the embodiments. If the pyrex is used as the cover glass and Si is used as the spacer, it is possible to bond with anodic bonding. In the case in which an adhesive layer is used, it is also possible to utilize a thermosetting adhesive and a thermosetting combination UV curing adhesive in addition to a UV curing adhesive for the adhesive layer.

In case that the semi-curing adhesive is applied for bonding, coating with the adhesive is performed in liquid state. And then, alignment is performed with semi-curing the adhesive. Therefore, it is possible to adjust positions when alignment is performed. Accordingly, it is possible to form a solid-state imaging device with sophisticated positioning.

Moreover, it is possible to properly select, as a spacer, a 42-alloy, metal, a glass, photosensitive polyimide and a polycarbonate resin in addition to a silicon substrate in all of the embodiments, which has also been described in the first embodiment.

When the IT-CCD substrate is to be bonded to the sealing cover glass by using the adhesive layer, furthermore, it is preferable that the molten adhesive layer should be prevented from flowing out, for example, a liquid reservoir should be formed. Referring to the bonded portion of the spacer and the IT-CCD substrate or the sealing cover glass, similarly, it is preferable that the molten adhesive layer should be prevented

46

from flowing out, for example, a concave or convex portion should be provided in a bonded portion to form a liquid reservoir as shown in an example of the shape of the bonded end of a spacer in FIGS. **51A** to **51F**.

Moreover, as shown in FIG. **52**, in order to reinforce the bonding between the IT-CCD substrate and the cover glass for shielding and prevent deterioration of the IT-CCD substrate, resin for shielding is applicable for shielding the bonding link between the glass substrate **2002** including cover glass **201** for shielding and the spacer **203s**, and resin M for shielding is applicable for shielding the bonding link between the spacer and the IT-CCD substrate **100**. Accordingly, it is possible to prevent the water from permeating into the bonding links and to obtain a reliable IT-CCD.

As a resin for shielding, epoxy, oxetany, silicony, acrylic, or such materials are properly. It is possible to apply for resin shielding any resins which can form a predetermined area for shielding, prevent the water from permeating into the bonding links, and obtain a reliable IT-CCD.

For forming the above mentioned IT-CCD, the resin for shielding is supplied to an area expecting the bonding pad BP (electrode pad) by using a dispenser and JIG for masking. And then, after curing the resin, the JIG masking the bonding pad is removed. Thereby, it is possible to process for resin shielding without coating the bonding pad. During this process, it is preferable to employ resins which is curable under 80 degree C. as well as the adhesives afore-mentioned as resins for shielding. As resins, it is preferable to use photocuring resin or thermal-curing resin. If the photo-curing resin is applied for shielding, it is preferable to use a light transmittable member as JIG

While the CMP is carried out up to the position of the cut trench in order to isolate the substrate provided with the cut trench into the individual elements in the embodiments, it is also possible to use grinding, polishing or overall etching.

In the case in which the reinforcing plate (**701**) is used in the embodiments, moreover, it can serve as an adiabatic substrate if a polyimide resin, ceramic, a crystallized glass, or a silicon substrate having a surface and back oxidized is used as a material if necessary. Furthermore, a shielding material may be used.

In the case in which it is necessary to stick the glass substrate to the spacer in the embodiments, moreover, the sticking may be executed by using an ultraviolet curing resin, a thermosetting resin or both of them or by applying a semi-curing adhesive. In the formation of the adhesive, furthermore, it is possible to properly select supply using a disperser, screen printing or stamp transfer.

In addition, the examples described in the embodiments can be modified mutually within an applicable range over whole configurations.

Forty-second Embodiment

As shown in a sectional view of FIG. **53A** and an enlarged sectional view illustrating a main part in FIG. **53B**, a solid-state imaging device is characterized in that a glass substrate **201** to be a translucent member is bonded to the surface of an IT-CCD substrate **100** comprising a silicon substrate **101** to be a semiconductor substrate provided with an IT-CCD **102** through a spacer **203S** in order to have a gap C corresponding to the light receiving region of the silicon substrate **101**, and furthermore, a conductor layer **209** is formed in a through hole **208** provided in the glass substrate **201** and the spacer **203S** and a pad **210** is formed on the upper surface of the glass substrate **201** in order to carry out a connection to a bonding pad BP of the silicon substrate **101**, and a signal fetch terminal

and a current supply terminal are formed thereon. The spacer **203S** has a height of 10 to 500 μm , and preferably 80 to 120 μm .

The structure of the IT-CCD substrate is almost same to the structure of the first embodiment.

In this embodiment, the upper layer of the filter layer **46** is covered with a microlens array comprising a microlens **50** formed by patterning a translucent resin containing a photosensitive resin having a refractive index of 1.3 to 2.0 by photolithography through a flattened insulating film **48** and then fusing the same translucent resin, and rounding the fused translucent resin by a surface tension and thereafter cooling the rounded translucent resin.

Next, description will be given to a process for manufacturing the solid-state imaging device. This method is based on a so-called wafer level CSP method in which positioning is carried out on a wafer level, collective mounting and integration are performed and isolation for each IT-CCD is then executed as shown in views illustrating the manufacturing process in FIG. **54A** to **E** and FIG. **55A** to **E** (only one unit is shown in the drawing and a plurality of IT-CCDs are continuously formed on one wafer). This method is characterized by the use of a sealing cover glass **200** having a spacer which is provided with a spacer **203S** in advance and a through hole penetrating through the glass substrate and the spacer.

More specifically, this method is characterized in that the spacer **203S** is stuck to the glass substrate **201** constituting the sealing cover glass **200** and the through hole **208** is formed to penetrate through the spacer **203S** and the glass substrate **201** in that state, and the conductor layer **209** is formed therein and the signal fetch terminal and the current supply terminal are formed on the surface side of the sealing cover glass **200**.

First of all, as shown in FIG. **54A**, a silicon substrate **203** having a thickness of 10 to 500 μm for forming the spacer is prepared.

As shown in FIG. **54A'**, next, the glass substrate **201** for constituting the sealing cover glass **200** is prepared.

As shown in FIG. **54B**, then, an adhesive layer **202** is applied onto the surface of the substrate **203**.

As shown in FIG. **54C**, thereafter, the silicon substrate **203** having the adhesive layer **202** applied thereto is stuck to the surface of the glass substrate **201**.

As shown in FIG. **54D**, subsequently, a resist pattern is formed by photolithography and RIE (reactive ion etching) is carried out by using the resist pattern as a mask, and an adhesive is previously applied to remove a concave portion **205** including a region corresponding to a photodiode, that is, a region corresponding to a light receiving region (**40** in FIG. **53B**) or a removal processing is carried out by an oxygen plasma after the RIE.

As shown in FIG. **54E**, then, a resist pattern is formed by the photolithography and the RIE (reactive ion etching) is carried out by using the resist pattern as a mask. Consequently, the through hole **208** is formed to penetrate through the spacer **203S** and the glass substrate **201**.

Thereafter, a silicon oxide film (not shown) is formed on at least the internal wall of the spacer formed of silicon by CVD if necessary.

In the case in which the spacer is formed by an insulator such as a glass or a resin, this step is not required. Moreover, a shielding film may be formed on the internal or external wall of the spacer.

As shown in FIG. **55A**, thereafter, the conductor layer **209** is formed on the internal wall of the through hole which is insulated by vacuum screen printing or metal plating using a conductive paste such as a silver paste or a copper paste, and

a through contact region penetrating through the spacer **203S** and the glass substrate **201** is formed.

As shown in FIG. **55B**, subsequently, gold bonding pads **210** and **211** or a bump **212** are/is formed on the surface and back face of the glass substrate having the spacer so as to be connected to the through contact region. In the film formation, a thin gold film is formed on the surface and the back face and patterning is carried out by an etching method using photolithography, or screen printing or selective plating can be applied.

Furthermore, an anisotropic conductive resin film **213** is applied as shown in FIG. **55C**.

On the other hand, as shown in FIG. **55D**, the IT-CCD substrate **100** provided with a reinforcing plate **701** is prepared

As shown in FIG. **55E**, then, an alignment is carried out with an alignment mark formed in the peripheral edge portion of each substrate, and the cover glass **200** having the spacer **203S** bonded to the plate-shaped glass substrate **201** is mounted on the IT-CCD substrate **100** formed as described above and is thus heated so that both of them are integrated with the anisotropic conductive film **213**. In the integration, diffusion bonding using an ultrasonic wave, solder bonding and eutectic bonding can also be applied.

Then, the whole device is subjected to dicing along a dicing line DC and division into individual solid-state imaging devices is carried out.

Thus, the solid-state imaging device provided with a contact region such as a bonding pad on a sealing cover glass can be formed very easily with a high workability.

Thus, the collective mounting is carried out and the individual isolation is then performed without the execution of an individual alignment and an electrical connection such as wire bonding. Therefore, manufacture can easily be carried out and handling can readily be performed.

Moreover, the trench section (not shown) is previously formed on the glass substrate **201** and the surface is removed to have such a depth as to reach the trench section by a method such as the CMP after the mounting. Therefore, the isolation can be carried out very easily.

Moreover, the formation can easily be carried out with a high workability. Furthermore, it is possible to form individual IT-CCDs by only cutting or polishing in a state in which an element formation surface is sealed in a gap C by the bonding. Therefore, it is possible to provide an IT-CCD in which the element is less damaged, dust is not mixed and has a high reliability.

In addition, the silicon substrate is thinned to have a depth of approximately $\frac{1}{2}$ by the CMP. Therefore, a size and a thickness can be reduced. Furthermore, the thickness is reduced after the bonding to the glass substrate. Consequently, it is possible to prevent a deterioration in a mechanical strength.

According to the structure of the invention, thus, positioning is carried out on a wafer level, and collective mounting and integration are sequentially performed for isolation every IT-CCD. Consequently, it is possible to form a solid-state imaging device which can easily be manufactured and has a high reliability.

While the wiring layer including the bonding pad is constituted by a gold layer in the first embodiment, it is apparent that the gold layer is not restricted but another metal such as aluminum or another conductor layer such as silicide can be used.

Moreover, the microlens array can also be provided by forming a transparent resin film on the surface of a substrate

49

and forming a lens layer having a refractive index gradient in a predetermined depth by ion implantation from the same surface.

Furthermore, it is possible to properly select, as the spacer, a glass or polycarbonate in addition to a silicon substrate.

Forty-third Embodiment

Next, a forty-third embodiment of the invention will be described.

While the description has been given to the solid-state imaging device in which the through hole penetrating through the glass substrate and the spacer is formed and the contact region such as a bonding pad is formed on the sealing cover glass in the forty-second embodiment, a variant will be described in the following embodiments.

First of all, the embodiment is characterized by the formation of a through hole on a spacer, and a glass substrate **201** is prepared as shown in FIG. **56A**.

As shown in FIG. **56B**, a photosetting resin is formed on the surface of the glass substrate **201** by a photo-molding method so that a spacer **213** is formed.

As shown in FIG. **56C**, then, a through hole **208** is formed by an etching method using photolithography.

Thus, it is possible to easily obtain a sealing cover glass having the spacer and provided with the through hole.

Subsequently, the mounting steps shown in FIGS. **55A** to **55E** are executed in the same manner as described in the forty-second embodiment, and sticking to an IT-CCD substrate is carried out to perform dicing. Consequently, the solid-state imaging device shown in FIG. **55E** can be obtained.

According to such a method, the spacer can easily be formed. While the photosetting resin is used in the embodiment, an adhesive itself may be utilized. The glass substrate and the spacer are formed integrally and a warp and a strain can be reduced, and furthermore, manufacture can also be carried out easily.

Forty-fourth Embodiment

Next, a forty-fourth embodiment of the invention will be described.

While the silicon substrate for forming the spacer is stuck to the glass substrate and is subjected to the patterning in the forty-second embodiment, a glass substrate may be etched at a one-time etching step to form a concave portion and a through hole at the same time in the embodiment. Other portions are formed in the same manner as those of the forty-second embodiment.

In the embodiment, first of all, a glass substrate **201** is prepared as shown in FIG. **57A**.

As shown in FIG. **57B**, then a resist pattern R is formed on the surface and back face of the glass substrate **201**, an opening is provided on both of the surface and back face in a region in which a through hole is to be formed and an opening is provided on only the back side in a region in which a concave portion **205** (and a cut trench **204** if necessary) is/are to be formed.

As shown in FIG. **57C**, thereafter, the glass substrate **201** is etched from both surfaces by using, as masks, the resist patterns on the surface and back face so that the concave portion **205**, a cut trench (not shown) and a through hole **208** are formed at the same time.

Thus, it is possible to easily obtain a sealing cover glass having a spacer formed integrally therewith and a through hole formed therein.

Subsequently, the mounting steps shown in FIGS. **55A** to **55E** are executed in the same manner as described in the forty-second embodiment, and sticking to an IT-CCD sub-

50

strate is carried out to perform dicing. Consequently, the solid-state imaging device shown in FIG. **55E** can be obtained.

The glass substrate and the spacer are formed integrally and a warp and a strain can be reduced, and furthermore, manufacture can also be carried out easily.

Forty-fifth Embodiment

Next, a forty-fifth embodiment of the invention will be described.

While the silicon substrate for forming a spacer is stuck to the glass substrate and is subjected to the patterning in the forty-second embodiment, a spacer **203S** having a pattern formed thereon is stuck to a glass substrate **201** and a through hole is finally formed at an etching step. Other portions are formed in the same manner as those of the forty-second embodiment.

First of all, in the embodiment, the glass substrate **201** is prepared as shown in FIG. **58A**.

On the other hand, a silicon substrate **203** for forming a spacer is prepared as shown in FIG. **58A'**.

As shown in FIG. **58B**, then, the silicon substrate **203** is processed by an etching method using photolithography so that the spacer **203S** is obtained.

As shown in FIG. **58C**, thereafter, an adhesive **202** is applied onto the surface of the spacer **203S** subjected to the patterning.

As shown in FIG. **58D**, subsequently, the spacer **203S** is stuck in alignment with the glass substrate **201**.

As shown in FIG. **58E**, then, a through hole **208** is formed by the etching method using the photolithography.

Thus, it is possible to easily obtain a sealing cover glass which has the spacer stuck thereto and the through hole formed thereon.

Thereafter, a silicon oxide film (not shown) is formed on at least the internal wall of the spacer formed of silicon by CVD if necessary.

In the case in which the spacer is formed by an insulator such as a glass or a resin, this step is not required. Moreover, a shielding film may be formed on the internal or external wall of the spacer.

Subsequently, the mounting steps shown in FIGS. **55A** to **55E** are executed in the same manner as described in the forty-second embodiment, and sticking to an IT-CCD substrate is carried out to perform dicing. Consequently, the solid-state imaging device shown in FIG. **55E** can be obtained.

It is also possible to stick the glass substrate to the spacer by using an ultraviolet curing resin, a thermosetting resin or both of them or applying a semicuring adhesive. In the formation of the adhesive, moreover, it is possible to properly select supply using a dispenser, screen printing or stamp transfer.

As shown in FIG. **58C**, moreover, it is also possible to form a shielding film **215** by a method of sputtering a tungsten film into the inside wall of the concave portion of the spacer.

Consequently, it is possible to obtain an excellent image pick-up characteristic without separately providing the shielding film.

Forty-sixth Embodiment

Next, a forty-sixth embodiment of the invention will be described.

In the forty-second embodiment, the description has been given to the example in which the silicon substrate for forming a spacer is stuck to the glass substrate and is patterned, and the through hole to penetrate through the glass substrate and the spacer is finally formed by etching. In the embodiment, as shown in FIGS. **59A** to **59F**, a shape processing is carried out

51

by etching a silicon substrate, and a spacer **203S** formed up to a through hole **208a** shown in FIG. **59E** and a glass substrate **201** provided with a through hole **208b** shown in FIG. **59B'** are aligned by using an alignment mark on a wafer level and both of them are stuck together with an adhesive layer **202**. Other portions are formed in the same manner as those in the forty-second embodiment.

Also in this case, it is also possible to form a shielding film (**215**) on an inside wall facing the concave portion of the spacer.

According to such a method, since the through holes are individually formed to carry out the sticking, the alignment is required and an almost half aspect ratio is enough. Consequently, the through hole can easily be formed.

Subsequently, the mounting steps shown in FIGS. **55A** to **55E** are executed in the same manner as described in the forty-second embodiment, and sticking to an IT-CCD substrate is carried out to perform dicing. Consequently, the solid-state imaging device shown in FIG. **55E** can be obtained.

It is also possible to form a conductor layer in each of the through holes of the spacer **203S** and the glass substrate **201** and to then align both of them to carry out the sticking.

Forty-seventh Embodiment

Next, a forty-seventh embodiment of the invention will be described.

In the forty-second embodiment, the silicon substrate for forming a spacer is stuck to the glass substrate and the conductor layer **209** is formed on the through hole penetrating through the glass substrate and the spacer at the etching step, and the IT-CCD substrate **100** is then stuck thereto. The embodiment is characterized in that the glass substrate **200** having a spacer which is provided with the through hole **208** in the first to forty-fifth embodiments is aligned with an IT-CCD substrate **100** having a reinforcing plate **701** stuck to a back face on a wafer level and they are stuck together, and the conductor layer **209** is then formed in the through hole **208** as shown in FIGS. **60A** to **60D**. Moreover, a bonding pad **210** is formed to be connected to the conductor layer **209**. Other portions are formed in the same manner as those in the twenty-eighth embodiment.

When the conductor layer **209** is to be filled, it is possible to easily carry out the formation by vacuum screen printing using a conductive paste such as a copper paste or metal plating.

While the description has been given to the method of carrying out, with an adhesive layer, the bonding of a glass substrate constituting a sealing cover glass to a spacer and the bonding of an IT-CCD substrate to the sealing cover glass in the embodiments, it is also possible to properly carry out the bonding through the surface activating cold bonding without using an adhesive in the case in which the spacer and the surface of the IT-CCD substrate is formed of Si, metal or an inorganic compound in all of the embodiments. If the cover glass is Pyrex, anode bonding can also be used when the spacer is formed of Si. In the case in which an adhesive layer is used, it is also possible to utilize, as the adhesive layer, a thermosetting adhesive, a semicuring type adhesive and a thermosetting combination UV curing adhesive in addition to a UV adhesive.

Moreover, it is possible to properly select, as a spacer, a 42-alloy, metal, a glass, photosensitive polyimide and a polycarbonate resin in addition to a silicon substrate in all of the embodiments, which has also been described in the forty-second embodiment.

52

When the IT-CCD substrate is to be bonded to the sealing cover glass by using the adhesive layer, furthermore, it is preferable that the molten adhesive layer should be prevented from flowing out, for example, a liquid reservoir should be formed. Referring to the bonded portion of the spacer and the IT-CCD substrate or the sealing cover glass, similarly, it is preferable that the molten adhesive layer should be prevented from flowing out, for example, a concave or convex portion should be formed to provide a liquid reservoir in the bonded portion.

While the CMP is carried out up to the position of the cut trench in order to isolate the substrate provided with the cut trench into the individual elements in the embodiments, it is also possible to use grinding, polishing or overall etching.

In the case in which the reinforcing plate (**701**) is used in the embodiments, moreover, it can serve as an adiabatic substrate if a polyimide resin, ceramic, a crystallized glass, or a silicon substrate having a surface and back oxidized is used as a material if necessary. Furthermore, a shielding material may be used.

Moreover, the formation may be carried out by using a moisture-proof sealing material or shielding material.

In the case in which it is necessary to stick the glass substrate to the spacer as described above, moreover, the sticking may be executed by using an ultraviolet curing resin, a thermosetting resin or both of them or by applying a semi-curing adhesive.

In the formation of the adhesive, furthermore, it is possible to properly select supply using a disperser, screen printing or stamp transfer.

In addition, the examples described in the embodiments can be modified mutually within an applicable range over whole configurations.

Forty-eighth Embodiment

As shown in a sectional view of FIG. **61A** and an enlarged sectional view illustrating a main part in FIG. **61B**, a solid-state imaging device has such a structure that a sealing cover glass itself is caused to have condensing and image forming functions to constitute an optical member. Consequently, a size can be more reduced.

A sealing cover glass **220** is provided by a method of forming lens regions having different refractive indices through molding or etching or ion implantation into the surface of a translucent polycarbonate resin. The glass substrate **220** having a lens to be the optical member is bonded to the surface of an IT-CCD substrate **100** comprising a silicon substrate **101** to be a semiconductor substrate provided with an IT-CCD **102** through a spacer **203S** in order to have a gap C corresponding to the light receiving region of the silicon substrate **101** and the peripheral edge of the silicon substrate **101** is individually isolated by dicing, and an electrical connection to an external circuit (not shown) can be achieved through a bonding pad BP formed on the surface of the silicon substrate **101**.

In this example, the bonding pad BP is formed to be exposed from the spacer **203S** in a partial region which is not shown, thereby constituting a signal fetch terminal and a current supply terminal. The spacer **203S** has a height of 10 to 500 μm , and preferably 80 to 120 μm .

The other portions of the IT-CCD in this embodiment are almost same to the IT-CCDs provided in the first embodiment, or the forty-second embodiment.

Next, a process for manufacturing the solid-state imaging device is shown in FIGS. **62A**, **62A'**, and **62B** to **62D** and FIGS. **63A** to **63C**.

53

As shown in FIG. 62A, a lens array is formed by an ion implanting method and the sealing cover glass 220 having the lens array is thus formed. The sealing cover glass 220 having the lens array can also be formed by molding or etching.

An adhesive layer 202 is formed on a silicon substrate 203 for a spacer as shown in FIG. 62A' and they are integrated as shown in FIG. 62C.

By using, as a mask, a resist pattern formed by an etching method using photolithography, etching is carried out to form the spacer 203S as shown in FIG. 62D.

Then, an adhesive layer 207 is formed on the surface of the spacer 203S of the sealing cover glass 220 having the lens array which is formed at the step shown in FIG. 62D.

On the other hand, the IT-CCD substrate 100 provided with a reinforcing plate 701 is prepared as shown in FIG. 63(b). In the formation of the element substrate, as shown in FIG. 63(b), the silicon substrate 101 (a 4 to 8 inch wafer is used) is prepared in advance (only one unit is shown in the drawing and a plurality of IT-CCDs are continuously formed on one wafer). It is also possible to easily carry out division after the mounting by a method of forming, through etching, a cut trench in a region corresponding to a dividing line for division into each IT-CCD over the surface of the silicon substrate 101.

Then, a channel stopper layer is formed, a channel region is formed and an element region 102 such as an electric charge transfer electrode . . . is formed by using an ordinary silicon process. Moreover, there is formed a bonding pad BP which is provided with a wiring layer on a surface and comprises a gold layer for an external connection.

As shown in FIG. 63(c), thereafter, an alignment is carried out with an alignment mark formed in the peripheral edge portion of each substrate, and the sealing cover glass 220 having the lens array to which the spacer 203S is bonded is mounted on the IT-CCD substrate 100 provided with the element region as described above, and heating is carried out to integrate both of them with the adhesive layer 207. It is desirable that this step should be executed in a vacuum or an inert gas atmosphere such as a nitrogen gas.

Moreover, a variant of the process for manufacturing the spacer and the sealing cover glass 220 having the lens array will be described in the following embodiments.

Forty-ninth Embodiment

Next, a forty-ninth embodiment of the invention will be described.

As shown in FIGS. 64A and 64B, the embodiment is characterized in that a sealing cover glass 220 having a lens array is prepared and a concave portion 225 is formed on the back side thereof by etching, and a spacer 223S is formed integrally. Other portions are formed in the same manner as those in the embodiments.

According to such a structure, the formation can easily be carried out with a high workability, and furthermore, it is possible to obtain the sealing cover glass 220 having a lens array in which a strain is not generated because of the integral formation and a reliability is enhanced.

Fiftieth Embodiment

Next, a fiftieth embodiment of the invention will be described.

In the embodiment, first of all, a glass substrate 220 having a lens array is prepared as shown in FIG. 65A.

As shown in FIG. 5B, then, a photo-curing resin is formed by a photo-molding method on the surface of the glass substrate 220 having a lens array and a spacer 223S is formed.

54

Thus, it is possible to easily obtain a sealing cover glass having the spacer and provided with a through hole.

Subsequently, the mounting steps shown in FIGS. 63A to 63C are executed in the same manner as described in the embodiments, and sticking to an IT-CCD substrate is carried out to perform dicing. Consequently, the solid-state imaging device shown in FIG. 63C can be obtained.

Fifty-first Embodiment

Next, a fifty-first embodiment of the invention will be described.

While the silicon substrate is stuck to the sealing cover glass 220 having the lens array and is subjected to the patterning in the forty-eighth embodiment, a spacer 203S formed by an etching method may be stuck to the cover glass 220 having the lens array as shown in FIGS. 66A to 66D in this example. At the mounting step, similarly, sticking to an IT-CCD substrate is carried out and dicing is performed in the same manner as in the fiftieth embodiment so that a solid-state imaging device can be obtained.

Fifty-second Embodiment

Next, a fifty-second embodiment of the invention will be described.

As shown in FIGS. 67A to 67D, moreover, a sealing cover glass 220 having a lens array, a spacer 203S and an IT-CCD substrate 100 having a reinforcing plate 701 may be fixed at the same time.

Fifty-third Embodiment

Next, a fifty-third embodiment of the invention will be described.

As shown in FIGS. 68A to 68D, moreover, a sealing cover glass 220 having a lens array can also be applied to a solid-state imaging device in which a peripheral circuit board 901 is provided through an anisotropic conductive film 115. Other portions are formed in the same manner as those in the embodiments.

Also in the connection of the peripheral circuit board 901, furthermore, diffusion bonding using an ultrasonic wave, solder bonding and eutectic bonding by thermocompression are also effective. In addition, underfilling using a resin may be carried out.

The sealing cover glass 220 having a lens array may be used in place of the sealing cover glass 200 formed by a plate-shaped member.

Fifty-fourth Embodiment

Next, a fifty-fourth embodiment of the invention will be described.

As shown in FIG. 69, moreover, an IT-CCD substrate 100, a peripheral circuit board 901 and a reinforcing plate 701 may be provided in this order. Other portions are formed in the same manner as those in the embodiments.

Fifty-fifth Embodiment

Next, a fifty-fifth embodiment of the invention will be described.

As shown in FIG. 70, moreover, it is also effective that a wiring 221 is formed on the side wall of a spacer.

In manufacture, it is possible to easily form a wiring on a side wall by providing a through hole in a spacer, forming a

conductor layer in the through hole, sticking an IT-CCD substrate to a sealing cover glass **220** having a lens and then carrying out division along a dicing line including the through hole. Other portions are formed in the same manner as those in the embodiments.

While the description has been given to the method of carrying out, with an adhesive layer, the bonding of a glass substrate constituting a sealing cover glass to a spacer and the bonding of an IT-CCD substrate to the sealing cover glass in the embodiments, it is also possible to properly carry out the bonding through the surface activating cold bonding without using an adhesive in the case in which the spacer and the surface of the IT-CCD substrate is formed of Si, metal or an inorganic compound in all of the embodiments. If the cover glass is Pyrex, anode bonding can also be used when the spacer is formed of Si. In the case in which an adhesive layer is used, it is also possible to utilize, as the adhesive layer, a thermosetting adhesive, a semicuring type adhesive and a thermosetting combination UV curing adhesive in addition to a UV adhesive.

Moreover, it is possible to properly select, as a spacer, a 42-alloy, metal, a glass, photosensitive polyimide and a polycarbonate resin in addition to a silicon substrate in all of the embodiments, which has also been described in the forty-second embodiment.

When the IT-CCD substrate is to be bonded to the sealing cover glass by using the adhesive layer, furthermore, it is preferable that the molten adhesive layer should be prevented from flowing out, for example, a liquid reservoir should be formed. Referring to the bonded portion of the spacer and the IT-CCD substrate or the sealing cover glass, similarly, it is preferable that the molten adhesive layer should be prevented from flowing out, for example, a concave or convex portion should be formed to provide a liquid reservoir in the bonded portion.

While the CMP is carried out up to the position of the cut trench in order to isolate the substrate provided with the cut trench into the individual elements in the embodiments, it is also possible to use grinding, polishing or overall etching.

In the case in which the reinforcing plate (**701**) is used in the embodiments, moreover, it can serve as an adiabatic substrate if a polyimide resin, ceramic, a crystallized glass, or a silicon substrate having a surface and back oxidized is used as a material if necessary. Furthermore, a shielding material may be used.

Moreover, the formation may be carried out by using a moisture-proof sealing material or shielding material.

In the case in which it is necessary to stick the glass substrate to the spacer in the embodiments, moreover, the sticking may be executed by using an ultraviolet curing resin, a thermosetting resin or both of them or by applying a semi-curing adhesive. In the formation of the adhesive, furthermore, it is possible to properly select supply using a disperser, screen printing or stamp transfer.

In addition, the examples described in the embodiments can be modified mutually within an applicable range over whole configurations.

While the wiring layer including the bonding pad is constituted by a gold layer in the forty-eighth embodiment, it is apparent that the gold layer is not restricted but another metal such as aluminum or another conductor layer such as silicide can be used.

Moreover, the microlens array can also be provided by forming a transparent resin film on the surface of a substrate and forming a lens layer having a refractive index gradient in a predetermined depth by ion implantation from the surface.

As shown in a sectional view of FIG. **71A** and an enlarged sectional view showing a main part in FIG. **71B**, a solid-state imaging device has such a structure that a sealing cover glass itself is caused to have condensing and image forming functions to constitute an optical member. Consequently, a size can be more reduced.

A sealing cover glass **220** is provided by forming lens regions having different refractive indices through ion implantation into the surface of a translucent polycarbonate resin. The glass substrate **220** having a lens to be the optical member is bonded to the surface of an IT-CCD substrate **100** comprising a silicon substrate **101** to be a first semiconductor substrate provided with an IT-CCD **102** through a spacer **203S** in order to have a gap C corresponding to the light receiving region of the silicon substrate **101**, and furthermore, a peripheral circuit board **901** comprising a silicon substrate to be a second semiconductor substrate is bonded to the back face of the IT-CCD substrate **100** and a contact pad **118** is formed on a back face, and furthermore, the peripheral edge of the silicon substrate **101** is individually isolated by dicing.

The structure of IT-CCD of this embodiment is almost same to the first embodiment and almost steps of the manufacturing method of the IT-CCD of this embodiment are same to the forty-eighth embodiment.

In this embodiment, a conductor layer **117** is formed on the back side of the IT-CCD substrate **100** to be connected to the IT-CCD substrate **100** via a through hole H, and furthermore, a pad **118** is formed so that the solid-state imaging device shown in FIG. **81A** is formed. A silicon oxide film **119** is formed on the internal wall of the through hole H.

Thus, it is possible to obtain a solid-state imaging device which can easily be mounted and has a small size and a high reliability.

Moreover, a variant of the process for manufacturing the spacer and the sealing cover glass **220** having the lens array will be described in the following embodiments.

Fifty-seventh Embodiment

Next, a fifty-seventh embodiment of the invention will be described.

As shown in FIGS. **74A** and **74B**, the embodiment is characterized in that a sealing cover glass **220** having a lens array is prepared and a concave portion **225** is formed on the back side thereof by etching, and a spacer **223S** is formed integrally.

According to such a structure, the formation can easily be carried out with a high workability, and furthermore, it is possible to obtain the sealing cover glass **220** having a lens array in which a strain is not generated because of the integral formation and a reliability is enhanced.

Fifty-eighth Embodiment

Next, a fifty-eighth embodiment of the invention will be described.

In the embodiment, first of all, a glass substrate **220** having a lens array is prepared as shown in FIG. **75A**.

As shown in FIG. **75B**, then, a photo-curing resin is formed on the surface of the glass substrate **220** having a lens array through a dispenser or screen printing and a spacer **223S** is formed.

Thus, it is possible to easily obtain a sealing cover glass having the spacer and provided with a through hole.

57

Subsequently, the mounting steps shown in FIGS. 73A to 73C are executed in the same manner as described in the embodiments, and sticking to an IT-CCD substrate is carried out, and furthermore, a peripheral circuit board 901 is bonded. Finally, a through hole is formed to electrically connect an IT-CCD substrate 100 to the peripheral circuit board 901, and dicing is then carried out. Consequently, the solid-state imaging device shown in FIG. 73C can be obtained.

Fifty-ninth Embodiment

Next, a fifty-ninth embodiment of the invention will be described.

In the fifty-ninth embodiment, as shown in FIGS. 76A, 76A', and 76B to 76D, a spacer 203S subjected to patterning may be stuck to a sealing cover glass 220 having a lens array.

Sixtieth Embodiment

Next, a sixtieth embodiment of the invention will be described.

As shown in FIGS. 77A to 77C, moreover, a sealing cover glass 220 having a lens array, a spacer 203S and an IT-CCD substrate 100 may be fixed at the same time.

Sixty-first Embodiment

Next, a Sixty-first embodiment of the invention will be described.

As shown in FIGS. 78A to 78D, moreover, a sealing cover glass 220 having a lens array can also be applied to a solid-state imaging device in which a peripheral circuit board 901 is provided through an anisotropic conductive film 115.

The sealing cover glass 220 having a lens array may be used in place of the sealing cover glass 200 formed by a plate-shaped member.

Also in the connection of the peripheral circuit board 901, furthermore, diffusion bonding using an ultrasonic wave, solder bonding and eutectic bonding by thermocompression are also effective. In addition, underfilling using a resin may be carried out.

Sixty-second Embodiment

Next, a sixty-second embodiment of the invention will be described.

As shown in FIG. 79, moreover, a through hole to penetrate through a peripheral circuit board and an IT-CCD substrate may be separately formed twice and a conductor layer 117 may be formed therein to be taken out downward. 221 denotes a wiring layer.

Sixty-third Embodiment

Next, a Sixty-third embodiment of the invention will be described.

As shown in FIG. 80, moreover, it is also effective that a wiring 221 is formed on the side wall of a spacer.

In manufacture, it is possible to easily form a wiring on a side wall by providing a through hole in a spacer, forming a conductor layer in the through hole, sticking an IT-CCD substrate to a sealing cover glass 220 having a lens and then carrying out division along a dicing line including the through hole.

While the description has been given to the method of bonding the IT-CCD substrate to the sealing cover glass with an adhesive layer in the embodiments, it is not restricted but

58

a method of pouring a mold resin, a method using direct bonding and cold activating direct bonding can also be applied.

When the IT-CCD substrate is to be bonded to the sealing cover glass by using the adhesive layer, furthermore, it is preferable that the molten adhesive layer should be prevented from flowing out, for example, a concave portion (a liquid reservoir) should be formed in a bonded portion.

In the method of the invention, thus, collective mounting is carried out and individual isolation is then performed without the execution of an individual alignment and an electrical connection such as wire bonding. Therefore, manufacture can easily be carried out and handling can also be performed readily.

According to the structure of the invention, thus, positioning is carried out on a wafer level, and collective mounting and integration are sequentially performed for isolation every IT-CCD. Consequently, it is possible to form a solid-state imaging device which can easily be manufactured and has a high reliability.

While the description has been given to the method of carrying out, with an adhesive layer, the bonding of a glass substrate constituting a sealing cover glass to a spacer and the bonding of an IT-CCD substrate to the sealing cover glass in the embodiments, it is also possible to properly carry out the bonding through the surface activating cold bonding without using an adhesive in the case in which the spacer and the surface of the IT-CCD substrate is formed of Si, metal or an inorganic compound in all of the embodiments. If the cover glass is Pyrex, anode bonding can also be used when the spacer is formed of Si. In the case in which an adhesive layer is used, it is also possible to utilize, as the adhesive layer, a thermosetting adhesive, a semicuring type adhesive and a thermosetting combination UV curing adhesive in addition to a UV adhesive.

Moreover, it is possible to properly select, as a spacer, a 42-alloy, metal, a glass, photosensitive polyimide and a polycarbonate resin in addition to a silicon substrate in all of the embodiments, which has also been described in the forty-second embodiment.

When the IT-CCD substrate is to be bonded to the sealing cover glass by using the adhesive layer, furthermore, it is preferable that the molten adhesive layer should be prevented from flowing out, for example, a liquid reservoir should be formed. Referring to the bonded portion of the spacer and the IT-CCD substrate or the sealing cover glass, similarly, it is preferable that the molten adhesive layer should be prevented from flowing out, for example, a concave or convex portion should be formed to provide a liquid reservoir in the bonded portion.

While the CMP is carried out up to the position of the cut trench in order to isolate the substrate provided with the cut trench into the individual elements in the embodiments, it is also possible to use grinding, polishing or overall etching.

In the case in which the reinforcing plate (701) is used in the embodiments, moreover, it can serve as an adiabatic substrate if a polyimide resin, ceramic, a crystallized glass, or a silicon substrate having a surface and back oxidized is used as a material if necessary. Furthermore, a shielding material may be used.

In the case in which it is necessary to stick the glass substrate to the spacer in the embodiments, moreover, the sticking may be executed by using an ultraviolet curing resin, a thermosetting resin or both of them or by applying a semicuring adhesive. In the formation of the adhesive, furthermore, it is possible to properly select supply using a disperser, screen printing or stamp transfer.

In addition, the examples described in the embodiments can be modified mutually within an applicable range over whole configurations.

While the wiring layer including the bonding pad is constituted by a gold layer in the fifty-sixth embodiment, it is apparent that the gold layer is not restricted but another metal such as aluminum or another conductor layer such as silicide can be used.

Moreover, the microlens array can also be provided by forming a transparent resin film on the surface of a substrate and forming a lens layer having a refractive index gradient in a predetermined depth by ion implantation from the surface.

Sixty-fourth Embodiment

As shown in a sectional view of FIG. 81A and an enlarged sectional view showing a main part in FIG. 81B, a solid-state imaging device has such a structure that a glass substrate 201 to be a translucent member is bonded to the surface of an IT-CCD substrate 100 comprising a silicon substrate 101 to be a semiconductor substrate provided with an IT-CCD 102 through a spacer 203S in order to have a gap C corresponding to the light receiving region of the silicon substrate 101, and furthermore, a peripheral circuit board 901 is connected to the back side.

A pad 113 and a bump 114 are formed to be external fetch terminals which are formed on the back side of the IT-CCD substrate 100 via a through hole H provided in the silicon substrate 101. Then, a connection to the peripheral circuit board 901 is carried out through an anisotropic conductive film 115 and a peripheral edge is individually isolated by dicing, and an external connection is thus carried out through a bonding pad 118. The spacer 203S has a height of 10 to 500 μm , and preferably 80 to 120 μm . The numeral 701 refers to a reinforcing plate.

In this embodiment, the IT-CCD substrate 100 has almost same structure to that of the first embodiment. The difference is that the through hole does not appear on the section but is formed to be connected to an electric charge transfer electrode 32 in this embodiment.

Next, description will be given to a process for manufacturing the solid-state imaging device. This method is based on a so-called wafer level CSP method in which positioning is carried out on a wafer level, collective mounting and integration are performed and isolation for each IT-CCD is then executed as shown in views illustrating the manufacturing process in FIGS. 82A to 82D and FIGS. 83A to 83C. (Only two units are displayed in the following drawings and a large number of IT-CCDs are continuously formed on a wafer). This method is characterized in that the edges of the IT-CCD substrate and a glass substrate are constituted equally and fetch on the back side is carried out via the through hole penetrating through the IT-CCD substrate 100 and the reinforcing plate 701 stuck to the back face thereof. Moreover, there is used a sealing cover glass 200 having a spacer which is provided with the spacer 203S in advance.

First of all, description will be given to the formation of the glass substrate having a spacer.

As shown in FIG. 82A, a silicon substrate 203 to be the spacer is stuck to the surface of the glass substrate 201 through an adhesive layer 202 comprising an ultraviolet curing type adhesive (a cation polymerizing energy line curing adhesive), and a resist pattern R1 is caused to remain in a portion to be the spacer by an etching method using photolithography.

As shown in FIG. 82B, then, the silicon substrate 203 is etched by using the resist pattern R1 as a mask so that the spacer 203S is formed.

As shown in FIG. 82C, thereafter, a resist is filled in a spacer region excluding an element region in a state in which the resist pattern R1 for forming the spacer 203S is left, and the glass substrate 201 is etched to have a predetermined depth. Consequently, an element trench section 204 is formed as shown in FIG. 82D. Subsequently, an adhesive layer 207 is formed on the surface of the spacer 203S. The spacer 203S is formed by the silicon substrate 203. For this reason, if the etching is carried out on such an etching condition that the etching speed of silicon oxide to be the principal component of the glass substrate 201 is much higher than the etching speed of silicon, the etching may be carried out with the side wall of the spacer 203S exposed to the element region. In the formation of the element trench section 204, a dicing blade (a grindstone) may be used.

Moreover, the photolithography may be carried out again to form such a resist pattern R as to include the whole side wall of the spacer 203S, and the etching may be carried out through the resist pattern R, thereby forming the trench section 204. Thus, the sealing cover glass 200 provided with the trench section 204 and the spacer 203S is obtained.

Next, the IT-CCD substrate is formed. In the formation of the element substrate, as shown in FIG. 83A, the silicon substrate 101 (a 4 to 8 inch wafer is used) is prepared in advance (only one unit is displayed in the following drawings and a large number of IT-CCDs are continuously formed on a wafer). By using an ordinary silicon process, then, a channel stopper layer is formed, a channel region is formed and an element region such as an electric charge transfer electrode . . . is formed. Thereafter, the reinforcing plate 701 formed by a silicon substrate which is provided with a silicon oxide film is bonded to the back face of the IT-CCD substrate 100 through surface activating cold bonding (FIG. 83A).

As shown in FIG. 83B, then, an alignment is carried out with an alignment mark formed in the peripheral edge portion of each substrate, and the cover glass 200 having the spacer 203S stuck to the plate-shaped glass substrate 201 is mounted on the IT-CCD substrate 100 formed as described above and is thus heated so that both of them are integrated with the adhesive layer 207. It is desirable that this process should be executed in a vacuum or an inert gas atmosphere such as a nitrogen gas.

Subsequently, the through hole H is formed on the back side of the reinforcing plate 701 by the photolithography. Then, a silicon oxide film 109 is formed in the through hole H by a CVD method. Thereafter, anisotropic etching is carried out to cause the silicon oxide film 109 to remain on only the side wall of the through hole H as shown in FIG. 83C.

As shown in FIG. 84A, subsequently, a tungsten film is formed as a conductor layer 108 to come in contact with the bonding pad in the through hole H by the CVD method using WF_6 .

As shown in FIG. 84B, then, the bonding pad 113 and the bump 114 are formed on the surface of the reinforcing plate 701.

Thus, it is possible to form a signal fetch electrode terminal and a conducting electrode terminal on the reinforcing plate 701 side.

As shown in FIG. 84C, thereafter, an anisotropic conductive film 115 (ACP) is applied onto the surface of the reinforcing plate 701.

As shown in FIG. 84D, finally, the circuit board 901 provided with a driving circuit is connected through the anisotropic conductive film 115. The circuit board 901 is provided

61

with a contact layer **117** formed by a conductor layer filled in the through hole **H** to penetrate through the board and a bonding pad **118**. A connection to the circuit board **901** can also be carried out through bonding using an ultrasonic wave, solder bonding or eutectic bonding.

Accordingly, it is possible to easily achieve a connection to a circuit board such as a printed board through the bonding pad **118**.

Then, the whole device is subjected to dicing along a dicing line **DC** including the contact layer **117** and the conductor layer **108** and isolation into individual solid-state imaging devices is thus carried out (only one unit is shown in the drawing and a plurality of IT-CCDs are continuously formed on one wafer).

Thus, the solid-state imaging device can be formed very easily with a high workability.

The reinforcing plate **701** is constituted by the silicon substrate provided with the silicon oxide film. Therefore, it is possible to carry out heat insulation and electrical insulation from the IT-CCD substrate **100**.

While the conductor layer is formed in the through hole **H** by the CVD method in the embodiment, moreover, it is possible to easily fill the conductive layer in the contact hole having a high aspect ratio with a high workability by using a plating method, a vacuum screen printing method or a vacuum sucking method.

While the electrical connection of the surface and back of the IT-CCD substrate and the circuit board mounting the peripheral circuit is carried out by using the through hole in the embodiment, furthermore, it is not restricted but a method of forming a contact to electrically connect the surface and the back by impurity diffusion from the surface and the back face can also be employed.

Thus, it is possible to form the signal fetch electrode terminal and the conducting electrode terminal on the reinforcing plate **701** side.

Furthermore, the collective mounting is carried out and the individual isolation is then performed without the execution of an individual alignment and an electrical connection such as wire bonding. Therefore, manufacture can easily be carried out and handling can also be performed readily.

Moreover, the trench section **204** is previously formed on the glass substrate **201** and the surface is removed to have such a depth as to reach the trench section **204** by a method such as the CMP after the mounting. Therefore, the isolation can be carried out very easily.

Furthermore, the individual IT-CCDs can be formed by only cutting or polishing in a state in which an element formation surface is enclosed in a gap **C** by the bonding. Consequently, it is possible to provide an IT-CCD in which the element is less damaged, dust is not mixed and a high reliability is obtained.

Moreover, the silicon substrate is thinned to have a depth of approximately $\frac{1}{2}$ by the CMP. Therefore, a size and a thickness can be reduced. Furthermore, the thickness is reduced after the bonding to the glass substrate. Consequently, it is possible to prevent a deterioration in a mechanical strength.

According to the structure of the invention, thus, positioning is carried out on a wafer level, and collective mounting and integration are sequentially performed for isolation every IT-CCD. Consequently, it is possible to form a solid-state imaging device which can easily be manufactured and has a high reliability.

While the formation is carried out by a method of performing a collective connection on a wafer level CSP and dicing in the embodiment, it is also possible to form the through hole **H**, to carry out the dicing over the IT-CCD substrate **100** provided with the bump **114** and to fix the sealing cover glass **200** individually.

62

In addition, a microlens array can also be provided by forming a transparent resin film on the surface of the substrate and forming a lens layer having a refractive index gradient in a predetermined depth by ion implantation from the same surface.

Moreover, it is possible to properly select, as a spacer, a 42-alloy, metal, a glass, photosensitive polyimide and a poly-carbonate resin in addition to a silicon substrate in all of the embodiments, which has also been described in the first embodiment.

Sixty-fifth Embodiment

Next, a sixty-fifth embodiment of the invention will be described.

While the through hole **H** is formed to penetrate through the reinforcing plate **701** and the conductor layer **111** is formed in the sixty-fourth embodiment, an IT-CCD substrate is formed by using a silicon substrate provided with a hole (a vertical hole) in advance in the embodiment. Since a small formation depth for the vertical hole is enough, consequently, a productivity can be enhanced and a manufacturing yield can be improved.

More specifically, as shown in FIG. **85A**, a resist pattern is first formed on the back face of the silicon substrate by photolithography prior to the formation of an IT-CCD, and a vertical hole **118** is formed by RIE (reactive ion etching) by using the resist pattern as a mask. At this step, a pad **110** formed of aluminum is provided on a surface and the vertical hole **118** is formed to reach the pad **110**.

As shown in FIG. **85B**, then, a silicon oxide film **119** is formed on the internal wall of the vertical hole **118** by a CVD method.

As shown in FIG. **85C**, thereafter, an element region for forming the IT-CCD is provided by using the same ordinary silicon process as that of each of the embodiments.

As shown in FIG. **85D**, subsequently, an alignment is carried out with an alignment mark formed in the peripheral edge portion of each substrate, and a cover glass **200** having a spacer **203S** bonded to a plate-shaped glass substrate **201** is mounted on an IT-CCD substrate **100** formed as described above and is thus heated so that both of them are integrated with an adhesive layer **207**. Similarly, surface activating cold bonding may be used at the bonding step.

As shown in FIG. **85E**, then, the reinforcing plate **701** is bonded to the back side of the IT-CCD substrate **100** through the surface activating cold bonding and a through hole **108** is formed to reach the vertical hole **118** from the back side by an etching method using the photolithography. Similarly, it is desirable that the internal wall of the through hole **108** should be insulated. Moreover, it is also possible to use a reinforcing plate provided with a through hole in advance.

Subsequently, the steps shown in FIGS. **84A** to **84D** described in the sixty-fourth embodiment are executed. Consequently, it is possible to easily form a solid-state imaging device having such a structure that a circuit board provided with a peripheral circuit is laminated.

In the embodiment, as described above, the small formation depth of the vertical hole is enough so that a productivity can be enhanced and a manufacturing yield can be improved.

Sixty-sixth Embodiment

Next, a sixty-sixth embodiment of the invention will be described.

In the sixty-fifth embodiment, the contact is formed to penetrate through the reinforcing plate **701**, the IT-CCD substrate and the circuit board and an electrode is fetched from the circuit board side. The embodiment is characterized in that a conductor layer **120** to be a wiring layer is formed on a

63

side wall and an electrode is fetched from the side wall of a solid-state imaging device as shown in FIGS. 86A and 86B.

A manufacturing process is almost the same as that of the sixty-fifth embodiment. The position of a through hole is set to correspond to each of the ends of the solid-state imaging device and dicing is carried out by using a cutting line DC including the through hole. Consequently, it is possible to easily form the solid-state imaging device having a wiring layer provided on a side wall.

Moreover, the conductor layer 120 to be filled in the through hole is constituted by a shielding material such as tungsten. Consequently, since the solid-state imaging device is shielded, a malfunction can be reduced.

When the reinforcing plate is constituted by a polyimide resin, ceramic, a crystallized glass or a silicon substrate having a surface and a back face oxidized, furthermore, it can function as an adiabatic substrate. Moreover, the reinforcing plate may be formed by a shielding material.

Sixty-seventh Embodiment

Next, a sixty-seventh embodiment of the invention will be described.

While the back side of the IT-CCD substrate 100 is provided on the peripheral circuit board through the reinforcing plate in the second and sixty-sixth embodiments, the IT-CCD substrate 100 is provided on a peripheral circuit board 901 and a reinforcing plate 701 is sequentially provided on the back side of the peripheral circuit board 901 as shown in FIG. 87 in the embodiment.

The reinforcing plate also serves as a radiation plate.

While a manufacturing process is almost the same as that of each of the second and sixty-sixth embodiments, the IT-CCD substrate 100 and the peripheral circuit board 901 are provided close to each other. Correspondingly, a connecting resistance can be reduced and high-speed driving can be carried out.

Sixty-eighth Embodiment

Next, a sixty-eighth embodiment of the invention will be described.

While the through hole is formed in the substrate and the electrode is fetched on the back side of the peripheral circuit board in the sixty-eighth embodiment, this example is characterized in that a conductor layer 121 to be a wiring layer is formed on a side wall as shown in FIG. 88.

In manufacture, in the same manner as in the sixty-sixth embodiment, it is possible to easily form a solid-state imaging device having a side wall wiring by only setting a dicing line into a position including a contact formed in a through hole.

In the solid-state imaging device, the wiring is formed on the side wall. Therefore, it is possible to form a signal fetch terminal and a current supply terminal on the side wall. It is apparent that a pad and a bump on the back side of a peripheral circuit board 901 may be formed to carry out a connection. 701 denotes a reinforcing plate.

While the description has been given to the method of carrying out, with an adhesive layer, the bonding of a glass substrate constituting a sealing cover glass to a spacer and the bonding of an IT-CCD substrate to the sealing cover glass in the embodiments, it is also possible to properly carry out the bonding through the surface activating cold bonding without using an adhesive in the case in which the spacer and the surface of the IT-CCD substrate is formed of Si, metal or an inorganic compound in all of the embodiments. If the cover glass is Pyrex, anode bonding can also be used when the

64

spacer is formed of Si. In the case in which an adhesive layer is used, it is also possible to utilize, as the adhesive layer, a thermosetting adhesive, a semicuring type adhesive and a thermosetting combination UV curing adhesive in addition to a UV adhesive.

Moreover, it is possible to properly select, as a spacer, a 42-alloy, metal, a glass, photosensitive polyimide and a polycarbonate resin in addition to a silicon substrate in all of the embodiments, which has also been described in the sixty-fourth embodiment.

When the IT-CCD substrate is to be bonded to the sealing cover glass by using the adhesive layer, furthermore, it is preferable that the molten adhesive layer should be prevented from flowing out, for example, a liquid reservoir should be formed. Referring to the bonded portion of the spacer and the IT-CCD substrate or the sealing cover glass, similarly, it is preferable that the molten adhesive layer should be prevented from flowing out, for example, a concave or convex portion should be formed to provide a liquid reservoir in the bonded portion.

While the CMP is carried out up to the position of the cut trench in order to isolate the substrate provided with the cut trench into the individual elements in the embodiments, it is also possible to use grinding, polishing or overall etching.

In the case in which the reinforcing plate (701) is used in the embodiments, moreover, it can serve as an adiabatic substrate if a polyimide resin, ceramic, a crystallized glass, or a silicon substrate having a surface and back face oxidized is used as a material if necessary. Furthermore, a shielding material may be used.

In the case in which it is necessary to stick the glass substrate to the spacer in the embodiments, moreover, the sticking may be executed by using an ultraviolet curing resin, a thermosetting resin or both of them or by applying a semicuring adhesive. In the formation of the adhesive, furthermore, it is possible to properly select supply using a disperser, screen printing or stamp transfer.

In addition, the examples described in the above embodiments can be modified mutually within an applicable range over whole configurations.

ADVANTAGE OF THE INVENTION

As described above, according to the method of manufacturing a solid-state imaging device in accordance with the invention, positioning is carried out on a wafer level and collective mounting is performed to achieve integration including the formation of an electrode terminal for external fetch, and isolation is then executed for each IT-CCD. Consequently, it is possible to form a solid-state imaging device which can easily be manufactured and has a high reliability.

As described above, according to the solid-state imaging device in accordance with the invention, a through hole is formed to penetrate through a spacer and a sealing cover glass and an electrode fetch terminal is provided on the sealing cover glass. Consequently, a connection to the outside can easily be carried out and a size can be reduced.

According to the method of manufacturing a solid-state imaging device in accordance with the invention, positioning is carried out on a wafer level, and a through hole is formed to penetrate through a spacer and a sealing cover glass and collective mounting is performed to achieve integration including the formation of an electrode terminal for external fetch which is provided on the sealing cover glass, and isolation is then executed for each IT-CCD. Consequently, it is possible to form a solid-state imaging device which can easily be manufactured and has a high reliability.

65

Additionally, as described above, according to the solid-state imaging device in accordance with the invention, a translucent substrate having an optical member such as a lens is used. Therefore, the optical member does not need to be mounted, and a size can be reduced and a reliability can be enhanced.

According to the method of manufacturing a solid-state imaging device in accordance with the invention, moreover, an IT-CCD substrate is positioned on a wafer level with respect to a translucent substrate having an optical member such as a lens, and collective mounting is performed to achieve integration including the formation of an electrode terminal for external fetch, and isolation is then executed for each IT-CCD. Consequently, it is possible to form a solid-state imaging device which can easily be manufactured and has a high reliability.

Moreover, according to the solid-state imaging device in accordance with the invention, a translucent substrate having an optical member, for example, a lens and a peripheral circuit board, and an IT-CCD substrate are bonded integrally. Therefore, it is possible to provide a solid-state imaging device which has a small size and a high reliability. C

According to the method of manufacturing a solid-state imaging device in accordance with the invention, moreover, an IT-CCD substrate is positioned on a wafer level with respect to a translucent substrate having an optical member such as a lens and a peripheral circuit board, and collective mounting is performed to achieve integration including the formation of an electrode terminal for external fetch, and isolation is then executed for each IT-CCD. Consequently, it is possible to form a solid-state imaging device which can easily be manufactured and has a high reliability.

As described above, according to the invention, it is possible to form a solid-state imaging device having a small size and a high driving speed.

According to the invention, moreover, positioning is carried out on a wafer level and the IT-CCD substrate, the peripheral circuit board and the translucent member are collectively mounted and are thus integrated, and are then isolated for each IT-CCD. Consequently, manufacture can easily be carried out and positioning can be performed with high precision.

What is claimed is:

1. A method of manufacturing a solid-state imaging device, comprising the steps of:

forming a plurality of IT-CCDs on a surface of a semiconductor substrate;

bonding a translucent member having a through hole filled with a conductive material on the surface of the semiconductor substrate in order to have a gap opposite to each light receiving region of the IT-CCD; and

isolating a bonded member obtained at the bonding step for every IT-CCD,

wherein the through hole is formed to penetrate through a spacer and a sealing cover glass, and wherein an electrode fetch terminal is provided on the sealing cover glass.

2. The method of manufacturing a solid-state imaging device according to claim 1, wherein the step of bonding a translucent member includes the steps of:

preparing a translucent substrate having a plurality of concave portions in positions corresponding to regions in

66

which the IT-CCDs are to be formed and a through hole in the vicinity of the concave portions; and

bonding the translucent substrate to the surface of the semiconductor substrate.

3. The method of manufacturing a solid-state imaging device according to claim 2, wherein at the bonding step, a gap is formed between the semiconductor substrate and the translucent member through a space provided to surround the light receiving region.

4. The method of manufacturing a solid-state imaging device according to claim 1, wherein the IT-CCD substrate and the translucent member are collectively mounted and are integrated prior to the isolating step.

5. The method of manufacturing a solid-state imaging device according to claim 1, wherein the distance between the light receiving region of the IT-CCD and the substrate is equal to or greater than 0.08 mm.

6. The method of manufacturing a solid-state imaging device according to claim 1, wherein the isolation step is carried out without forming a cut trench on the substrate.

7. A method of manufacturing a solid-state imaging device, comprising the steps of:

forming a plurality of IT-CCDs on a surface of a semiconductor substrate;

forming a protruded portion on the surface of the semiconductor substrate to surround a light receiving region prior to a bonding step, a gap being formed between the light receiving region and the translucent member by the protruded portion;

bonding a translucent member having a through hole filled with a conductive material on the surface of the semiconductor substrate in order to have a gap opposite to each light receiving region of the IT-CCD; and

isolating a bonded member obtained at the bonding step for every IT-CCD,

wherein the step of bonding a translucent member includes the steps of:

preparing a translucent substrate having a plurality of concave portions in positions corresponding to regions in which the IT-CCDs are to be formed and a through hole in the vicinity of the concave portions; and

bonding the translucent substrate to the surface of the semiconductor substrate.

8. The method of manufacturing a solid-state imaging device according to claim 7, wherein the through hole is formed to penetrate through a spacer and a sealing cover glass, and wherein an electrode fetch terminal is provided on the sealing cover glass.

9. The method of manufacturing a solid-state imaging device according to claim 7, wherein the IT-CCD substrate and the translucent member are collectively mounted and are integrated prior to the isolating step.

10. The method of manufacturing a solid-state imaging device according to claim 7, wherein the distance between the light receiving region of the IT-CCD and the substrate is equal to or greater than 0.08 mm.

11. The method of manufacturing a solid-state imaging device according to claim 7, wherein the isolation step is carried out without forming a cut trench on the substrate.

* * * * *