

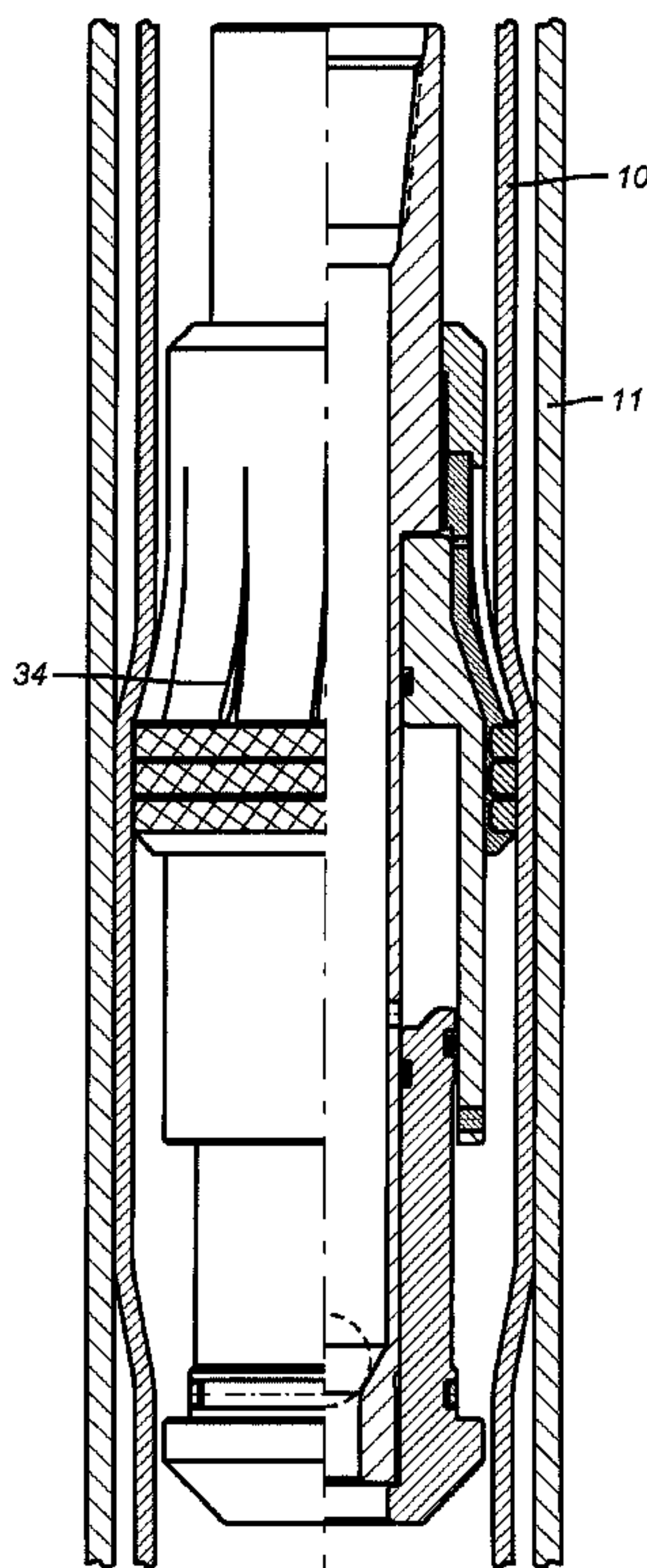

(22) Date de dépôt/Filing Date: 2001/10/04
 (41) Mise à la disp. pub./Open to Public Insp.: 2002/04/10
 (45) Date de délivrance/Issue Date: 2005/08/16
 (30) Priorité/Priority: 2000/10/10 (09/685,264) US

(51) Cl.Int.⁷/Int.Cl.⁷ E21B 23/00
 (72) Inventeur/Inventor:
 BAUGH, JOHN L., US
 (73) Propriétaire/Owner:
 BAKER HUGHES INCORPORATED, US
 (74) Agent: SIM & MCBURNEY

(54) Titre : REDRESSE-TUBES FLEXIBLE
 (54) Title: FLEXIBLE SWEDGE



(57) Abrégé/Abstract:

A swedge assembly is disclosed which has the capability of allowing for a sealing connection between an inner tubular and an outer tubular where the outer tubular has significant out of roundness. A resilient segment or segments is disposed on the swedge in contact with the inner tubular to be expanded so as to fill any voids created by out of roundness of the outer tubular. The resilient material may be an elastomer or any pliable metallic or any other material compatible with the applicable well bore conditions.

ABSTRACT

A swedge assembly is disclosed which has the capability of allowing for a
5 sealing connection between an inner tubular and an outer tubular where the outer
tubular has significant out of roundness. A resilient segment or segments is disposed
on the swedge in contact with the inner tubular to be expanded so as to fill any voids
created by out of roundness of the outer tubular. The resilient material may be an
elastomer or any pliable metallic or any other material compatible with the applicable
10 well bore conditions.

FLEXIBLE SWEDGE

Field of the Invention

5

The field of this invention relates to swedges, tubular expansion devices, which can seal an inner pipe to an outer pipe by expansion when the outer pipe is somewhat out of round without need to expand the outer pipe.

Background of the Invention

10

In the past, techniques have been developed to expand an inner pipe against an outer pipe and such techniques have been applied to attach a liner to casing in a well bore. Because segments of well bore casing could be out of round prior techniques have required a swedge system to have sufficient power to not only expand the inner tubular but also to expand the outer tubular to insure fixation in a full

15 circumferential manner of the inner tubing against the outer tubing. This technique illustrated in U.S. Patent 6,098,717 required the inner tubular to be expanded beyond the yield point by drawing a swedge through it. The inner tubular expanded sufficiently such that the elastic recovery for the inner tubular was less than the elastic recovery for the outer tubular to insure that the tubulars sealed against each other.

20 While this technique was effective, it required significant amount of pulling force or applied horsepower on the swedge.

25

However, there are applications where the power available to drive the swedge is limited but the circumstances still call for a reliable sealed connection between the inner tubular and the outer tubular in circumstances where the outer tubular could be somewhat out of round. It is therefore an object of the present invention to be able to accommodate situations where the outer tubular is out of round and expand an inner

-2-

tubular assembly in such a manner as to fully seal in the portions of the outer tubular which are out of round. It is a further object of the present invention to reduce the required applied force driving the swedge to make a sealed connection between the inner and outer tubulars. Those advantages and others will be readily apparent to those skilled in the art from a review of the description of the preferred embodiment which appears below.

Summary of the Invention

A swedge assembly is disclosed which has the capability of allowing for a sealing connection between an inner tubular and an outer tubular where the outer tubular has significant out of roundness. A resilient segment or segments is disposed on the swedge in contact with the inner tubular to be expanded so as to fill any voids created by out of roundness of the outer tubular. The resilient material may be an elastomer or any pliable metallic or any other material compatible with the applicable well bore conditions.

According to one aspect of the present invention there is provided a method of expanding an inner tubular into a surrounding out of round tubular comprising:

inserting an expansion tool into the inner tubular;

inserting a portion of said inner tubular into said surrounding out of round tubular;

providing a load distributing feature on said expansion tool which allows for said distributing by continuous contact for 360 degrees with said inner tubular; and expanding said inner tubular into circumferential contact with said surrounding out of round tubular.

-2a-

- According to another aspect of the present invention there is provided a method of expanding an inner tubular into a surrounding out of round tubular comprising:
- inserting an expansion tool into the inner tubular;
 - 5 inserting a portion of said inner tubular into said surrounding out of round tubular;
 - providing a load distributing feature on said expansion tool;
 - expanding said inner tubular into circumferential contact with said surrounding out of round tubular;
 - 10 providing a resilient material in said expansion tool as said load distributing feature;
 - using said resilient material to apply the requisite expansion force to said inner tubular for contact with an out of round segment of said surrounding out of round tubular;
 - 15 providing at least one circumferential ring of said resilient material on said expansion tool;
 - locating said resilient material in a peripheral groove;
 - using rigid portions of said expansion tool for expansion of said inner tubular to at least 95% of its final dimension; and
 - 20 using said resilient material to complete the remaining expansion of said inner tubular into full 360 degree circumferential contact with said surrounding out of round tubular.

-2b-

According to yet another aspect of the present invention there is provided a method of expanding an inner tubular into a surrounding out of round tubular, comprising:

- 5 inserting a portion of said inner tubular into said surrounding out of round tubular;
- applying an expansion force to said inner tubular;
- distributing said expansion force over a continuous 360 degrees to a portion of said inner tubular that needs to expand further to contact a void caused by out of roundness of said surrounding out of round tubular; and
- 10 minimizing expansion of said surrounding out of round tubular by virtue of said distributing of said expansion force.

According to yet another aspect of the present invention there is provided an expansion tool for expanding an inner tubular into a surrounding out of round tubular comprising:

- 15 a mandrel;
- a movable wedge on said mandrel;
- at least one non-segmented sleeve expandable by said wedge into said inner tubular; and
- a continuous load distributing device on said sleeve which facilitates
- 20 incremental expansion of said inner tubular into voids due to out of roundness in the surrounding out of round tubular.

According to still yet another aspect of the present invention there is provided an expansion tool for expanding an inner tubular into a surrounding out of round tubular comprising:

-2c-

a mandrel;

a movable wedge on said mandrel;

at least one sleeve expandable by said wedge into said inner tubular;

a load distributing device on said sleeve which facilitates incremental

5 expansion of said inner tubular into voids due to out of roundness in the surrounding
out of round tubular, said load distributing device comprising a resilient material, said
resilient material forming a ring shape on said sleeve; and

a plurality of resilient ring shapes on said sleeve.

Brief Description of the Drawing

10 An embodiment of the present invention will now be described more fully
with reference to the accompanying drawings in which:

Figure 1 is a section view of the apparatus in the run in position.

Figure 2 is a section view of the apparatus in the expanded position.

Detailed Description of the Preferred Embodiment

15 Referring now to Figure 1, the apparatus **A** is shown inserted into an inner
tubular **10** which is in turn in a bigger tubular or casing **11**. The apparatus has a
mandrel **12** to which is attached a movable tapered component or wedge **14**. Wedge
14 can be operated hydraulically with pressurized gas mechanically or by other
means.

20

Referring to Figure 1, it can be seen that the wedge 14 has a leading end 16 which sits under an inner sleeve 18. Inner sleeve 18 holds one or more seals 20. Seals 20 can be made from non-metallics, soft metals, composite materials, plastics, or any other material compatible with down hole well conditions chemically, thermally, and mechanically. Some examples of usable materials would include aluminum, elastomers, and PTFE. The seals 20 are disposed in peripheral grooves such as 22 so that each seal 20 has an outer face 24 which can engage the inner tubular 10 to expand it against the casing 11 as shown on Figure 2.

An outer sleeve 26 is retained to mandrel 12 by thread 30. Outer sleeve 26 has longitudinal splits 34 which are shown on Figure 2 as increasing in size due to the expansion caused by advancing the wedge 14. The splits 34 do not go to the end 36 of the outer sleeve 26 thereby creating a plurality of finger-like segments 38 which expand to engage the inner tubular 10.

In operation, the well bore casing 11 receives a smaller tubular or casing such as 10 to be expanded into contact with it. The wedge 14 is operated to effectively increase the size of the tubular 10 into sealing contact with casing 11. Figure 2 shows the inner sleeve 18 along with the one or more seals 20 after expansion of the tubular 10 against its surrounding casing 11. The advantage of the seal or seals 20 can now readily be appreciated. In the event there are out of roundness conditions in the casing 11 against which the tubular 10 is to be expanded, greater expansion of the tubular 10 can occur to conform tubular 10 to those irregularities because internally the seal or seals 20 respond to the increased loading due to the out of roundness in the casing 11 so as to allow tubular 10 under the redistributed force through the seal or seals 20 to expand further in the locale of the surrounding casing 11 where it is larger

due to out of roundness. Out of roundness as large as $\pm .060$ inches or more can be accommodated in this manner. In essence, the ability of the seal or seals **20** to distribute the load allows for compensation for out of roundness in the surrounding casing or tubular **11** into which the tubular **10** must be expanded. In essence, the rigid components of the apparatus A accomplish a majority of the necessary expansion of the tubular **10** in the order of 95 percent or more of the requisite expansion to firmly engage the tubular **10** to most of its surrounding outer casing **11**. The presence of the seal or seals **20** allows additional expansion forces to be applied to further expand the tubular **10** into any voids caused by out of roundness in the surrounding tubular. The softness of the seals **20** gives a fluid type property to the seal allowing it to equalize the load circumferentially so that further expansion can take place where there is less resistance due to out of roundness and a circumferential seal of 360E can be obtained as between the tubular **10** and its surrounding casing **11** due to the further expansion facilitated by the seal or seals **20** into any void areas in the surrounding casing.

By using the apparatus A the power requirements are greatly reduced because there is no requirement to appreciably expand the casing **11** to accomplish the seal as was the case in U.S. Patent 6,098,717.

Those skilled in the art will appreciate that the above described preferred embodiment is illustrative of the invention and the scope of the invention is determined by the claims below.

What is claimed is:

1. A method of expanding an inner tubular into a surrounding out of round tubular comprising:
 - 5 inserting an expansion tool into the inner tubular;
inserting a portion of said inner tubular into said surrounding out of round tubular;
providing a load distributing feature on said expansion tool which allows for said distributing by continuous contact for 360 degrees with said inner tubular; and
 - 10 expanding said inner tubular into circumferential contact with said surrounding out of round tubular.

2. The method of claim 1, comprising:
 - 15 providing a resilient material in said expansion tool as said load distributing feature; and
using said resilient material to apply the requisite expansion force to said inner tubular for contact with an out of round segment of said surrounding out of round tubular.

- 20 3. The method of claim 2, comprising:
 - providing at least one circumferential ring of said resilient material on said expansion tool.

4. The method of claim 3, comprising:

-6-

locating said resilient material in a peripheral groove.

5. The method of claim 4, comprising:
using rigid portions of said expansion tool for expansion of said inner tubular
5 to at least 95% of its final dimension.
6. The method of claim 1, comprising:
obtaining 360 degree sealing contact with said surrounding out of round
tubular.
10
7. The method of claim 6, comprising:
avoiding significant expansion of said surrounding out of round tubular.
8. A method of expanding an inner tubular into a surrounding out of round
15 tubular comprising:
inserting an expansion tool into the inner tubular;
inserting a portion of said inner tubular into said surrounding out of round
tubular;
providing a load distributing feature on said expansion tool;
20 expanding said inner tubular into circumferential contact with said
surrounding out of round tubular;
providing a resilient material in said expansion tool as said load distributing
feature;

-7-

using said resilient material to apply the requisite expansion force to said inner tubular for contact with an out of round segment of said surrounding out of round tubular;

5 providing at least one circumferential ring of said resilient material on said expansion tool;

locating said resilient material in a peripheral groove;

using rigid portions of said expansion tool for expansion of said inner tubular to at least 95% of its final dimension; and

10 using said resilient material to complete the remaining expansion of said inner tubular into full 360 degree circumferential contact with said surrounding out of round tubular.

9. A method of expanding an inner tubular into a surrounding out of round tubular, comprising:

15 inserting a portion of said inner tubular into said surrounding out of round tubular;

applying an expansion force to said inner tubular;

20 distributing said expansion force over a continuous 360 degrees to a portion of said inner tubular that needs to expand further to contact a void caused by out of roundness of said surrounding out of round tubular; and

minimizing expansion of said surrounding out of round tubular by virtue of said distributing of said expansion force.

10. The method of claim 9, comprising:

-8-

providing a resilient material in an expansion tool;
inserting said expansion tool into said inner tubular;
using said resilient material to provide the requisite expansion force of said
inner tubular for contact with an out of round segment of said surrounding out of
5 round tubular.

11. The method of claim 10, comprising:
providing at least one circumferential ring of said resilient material on said
expansion tool.

10

12. The method of claim 11, comprising:
locating said resilient material in a peripheral groove.

13. An expansion tool for expanding an inner tubular into a surrounding out of
15 round tubular comprising:

a mandrel;

a movable wedge on said mandrel;

at least one non-segmented sleeve expandable by said wedge into said inner
tubular; and

20 a continuous load distributing device on said sleeve which facilitates
incremental expansion of said inner tubular into voids due to out of roundness in the
surrounding out of round tubular.

14. The tool of claim 13, wherein:

-9-

said load distributing device comprises a resilient material.

15. The tool of claim 14, wherein:

said resilient material forms a ring shape on said sleeve.

5

16. An expansion tool for expanding an inner tubular into a surrounding out of round tubular comprising:

a mandrel;

a movable wedge on said mandrel;

10 at least one sleeve expandable by said wedge into said inner tubular;

a load distributing device on said sleeve which facilitates incremental expansion of said inner tubular into voids due to out of roundness in the surrounding out of round tubular, said load distributing device comprising a resilient material, said resilient material forming a ring shape on said sleeve; and

15 a plurality of resilient ring shapes on said sleeve.

17. The tool of claim 16, comprising:

an inner sleeve comprising exposed peripheral grooves in which said resilient ring shapes are disposed.

20

18. The tool of claim 17, comprising:

an outer sleeve mounted over a portion of said inner sleeve and further comprising at least one longitudinal split that extends for a majority of its length.

-10-

19. The tool of claim 18, comprising:

a drive for said wedge, said drive being one of mechanically, hydraulically,
and pressurized gas powered.

1/2

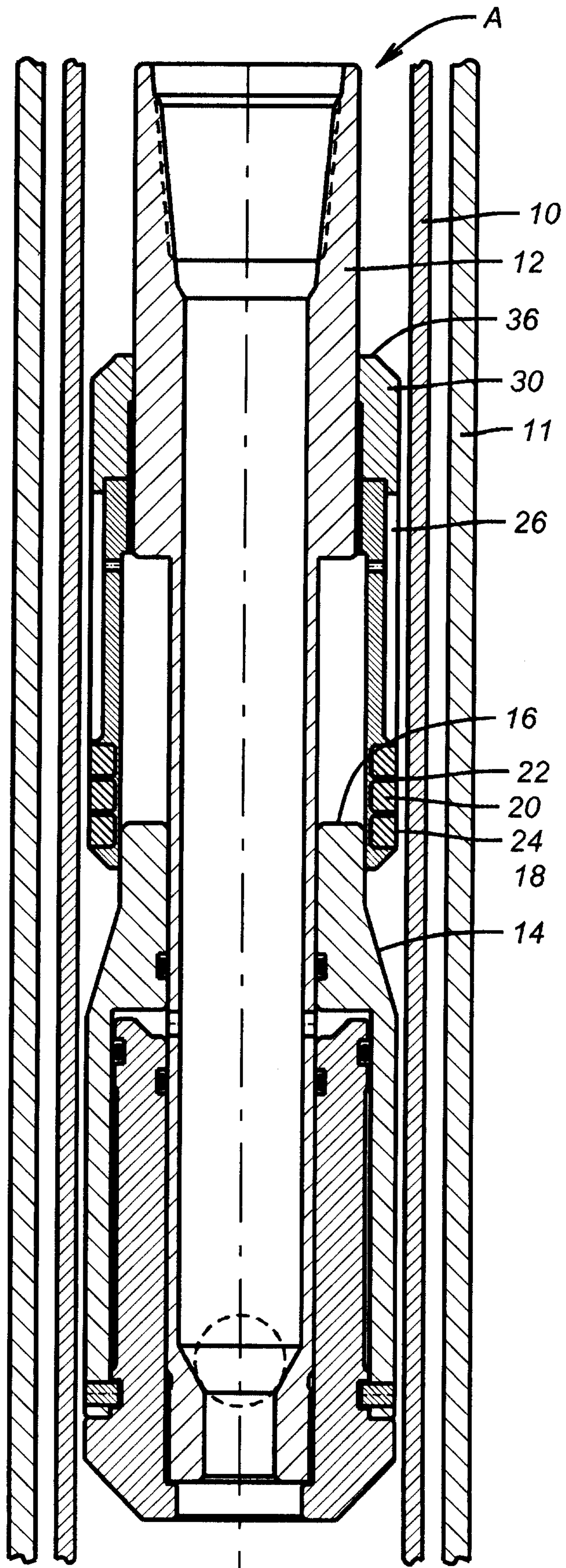

FIG. 1

2/2

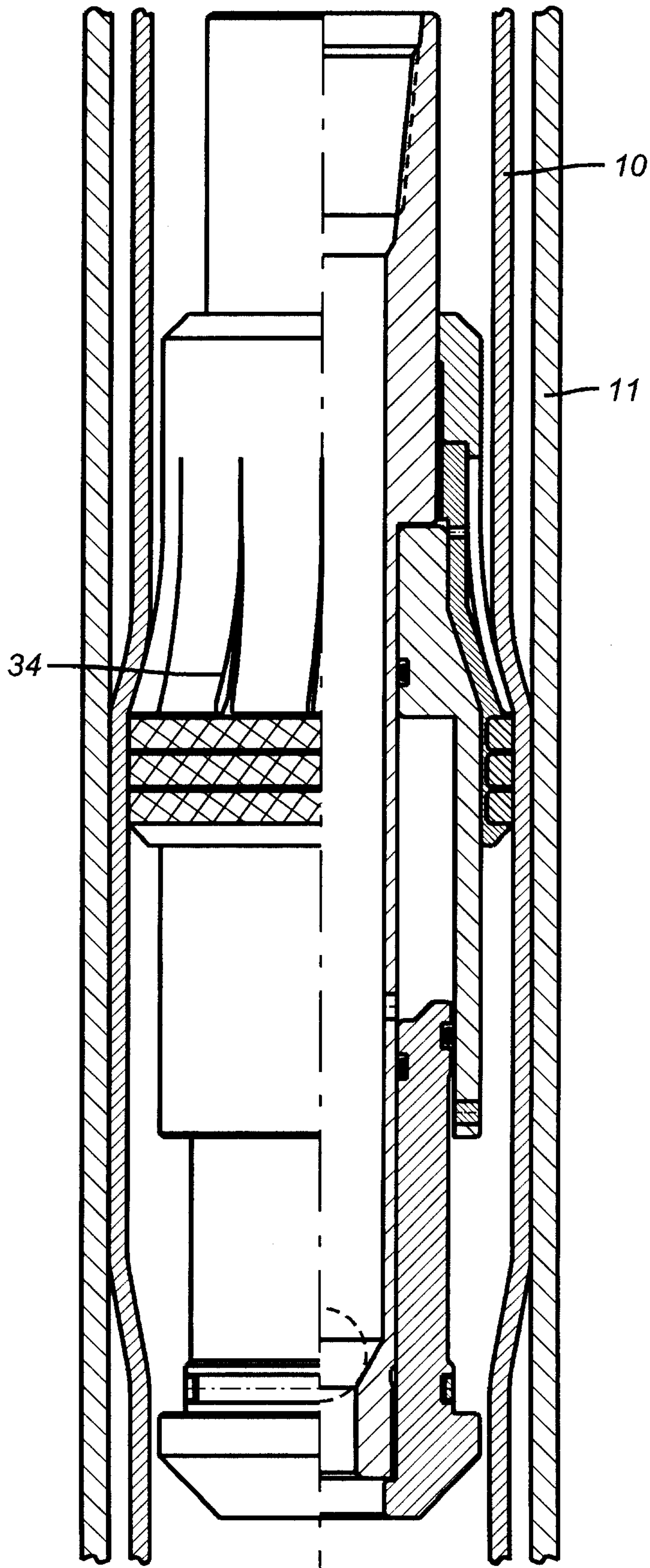

FIG. 2

