

(19) World Intellectual Property
Organization
International Bureau



(43) International Publication Date
10 February 2005 (10.02.2005)

PCT

(10) International Publication Number
WO 2005/011419 A2

- (51) International Patent Classification⁷: **A43B** LK, LR, LS, LT, LU, LV, MA, MD, MG, MK, MN, MW, MX, MZ, NO, NZ, OM, PH, PL, PT, RO, RU, SD, SE, SG, SK, SL, TJ, TM, TN, TR, TT, TZ, UA, UG, US, UZ, VN, YU, ZA, ZM, ZW.
- (21) International Application Number: PCT/US2003/016251
- (22) International Filing Date: 2 July 2003 (02.07.2003) (84) Designated States (regional): ARIPO patent (GH, GM, KE, LS, MW, MZ, SD, SL, SZ, TZ, UG, ZM, ZW), Eurasian patent (AM, AZ, BY, KG, KZ, MD, RU, TJ, TM), European patent (AT, BE, BG, CH, CY, CZ, DE, DK, EE, ES, FI, FR, GB, GR, HU, IE, IT, LU, MC, NL, PT, RO, SE, SI, SK, TR), OAPI patent (BF, BJ, CF, CG, CI, CM, GA, GN, GQ, GW, ML, MR, NE, SN, TD, TG).
- (25) Filing Language: English
- (26) Publication Language: English
- (71) Applicants and
(72) Inventors: **RENNEX, Brian, G.** [US/US]; POB 10693, Rockville, MD 20849 (US). **HOGAN, Bartholomew, P.** [—/—]; 306 Cotar Lane, Rockville, MD 20851 (**).
- (81) Designated States (national): AE, AG, AL, AM, AT, AU, AZ, BA, BB, BG, BR, BY, BZ, CA, CH, CN, CO, CR, CU, CZ, DE, DK, DM, DZ, EC, EE, ES, FI, GB, GD, GE, GH, GM, HR, HU, ID, IL, IN, IS, JP, KE, KG, KP, KR, KZ, LC,
- Published:**
— without international search report and to be republished upon receipt of that report
- For two-letter codes and other abbreviations, refer to the "Guidance Notes on Codes and Abbreviations" appearing at the beginning of each regular issue of the PCT Gazette.*



WO 2005/011419 A2

(54) Title: FULL ENERGY RETURN SHOE

(57) Abstract: This invention is a full energy return shoe. It comprises various embodiments of a "full energy return" linkage attached to upper and lower sole plates along their full lengths. This linkage constrains relative motion of the upper and lower plates by limiting or eliminating relative tilting and by controlling or eliminating relative longitudinal motion. These constraints result in foot impact energy being stored in springs irregardless of whether the force acts on the front or rear of the sole. That is, both toe and heel impact energy are used or returned during toe-off. These spring are coupled to links or vertices of the linkage and are designed to achieve an optimal ground reaction force curve of the shoe on the ground - varying from linear to constant curves. Useful features include a push-off frame to allow heel lift and a flex-rigger to prevent sprained ankles.

Background

This application is a CIP of US Patent Application 10/026797 filed 12/27/2001. This invention is a full energy return shoe. It comprises various embodiments of a "full energy return" linkage, referred to herein a sole linkage, attached to upper and lower sole plates along their full lengths. This linkage constrains relative motion of the upper and lower plates by limiting or eliminating relative tilting and by controlling or eliminating relative longitudinal motion. These constraints result in foot impact energy being stored in springs irregardless of whether the force acts on the front or rear of the sole. That is, both toe and heel impact energy are used or returned during toe-off. These spring are coupled to links or vertices of the linkage and are designed to achieve an optimal ground reaction force curve of the shoe on the ground - varying from linear to constant curves. Useful features include a push-off frame to allow heel lift and a flex-rigger to prevent sprained ankles.

The first embodiment of the space shoe is called a space shoe because most of the skeletal sole is free space rather than a solid, foam-filled structure. The springs of the space shoe act directly between elements of the sole linkage which acts on the ground plate and the shoe plate; that is, these springs are located at shoe or sole level. The second embodiment of the invention is called a bow shoe; its bow spring is located up to the shin level.

The space shoe provides for the following improvements which will referred to in the discussion of prior art as S1, S2, and S3. (S1) It has an improved mechanism to capture both heel and toe impact energy and return all impact energy through the toe during the latter part of toe-off. The extent of the sole linkage along the full sole length is key and distinguishes it from prior art. (S2) It provides for optimal stability by constraining the upper shoe plate to have minimal or no relative longitudinal or tilting motion with respect to the lower sole plate -- via the sole linkage. Improvement (S2) is referred to herein as sole tilting/sliding. Improvement (S3) is that a natural running action is allowed -- where this running action comprises both a natural roll-over from heel to toe and a push-off -- with the wearer's metatarsal joint freely flexing and the heel lifting into the air during toe-off.

Seven categories of prior shoe art with springs or relevant features are listed below. Examples of each category will be given, along with limitations overcome by the space shoe improvements which improvements will be referred to by the numbers S1 to S3 mentioned above. The first category has multiple springs located throughout the sole or only in the heel. Examples include U.S. Patent # 5,621,984 of Hsieh and U.S. Patent #5,337,492 of Anderie. Space-shoe improvements S1, S2, and S3 apply to this category which prior art notably permits sole tilting (S3) in a see-saw manner which does not couple spring energy for toe thrust and which dissipates heel impact energy in mid-stance (S1). With regard to improvement (S1), as the wearer's heel lifts to push-off, the prior-art heel springs release their energy prematurely, the wearer's knee bends and his ankle dorsi-flexes during which time the heel impact energy is largely dissipated. In fact, for this heel impact energy to efficiently propel the wearer up and forward, it must act through the

wearer's toe during the latter part of toe-off.

The second category of "springs in soles" prior art has a means to capture all of the heel impact energy for energy return at toe-off. An example is U.S. Patent # 4,936,03 of Rennex. Improvements (S2 & S3) apply, and the space-shoe mechanism to achieve improvement (S1) is considerably simpler and cheaper. The third category of "springs in soles" prior art has a linkage to constrain a compressible sole as a spring stores impact energy. Examples include U.S. Patent # 4,534,124 of Schnell, U.S. Patent #5,896,679 of Baldwin, U.S. Patent # 5,701,685 of Pezza. Space-shoe improvements (S2 and S3) apply to Schnell and Pezza. Improvements (S1, S2, and S3) apply to Baldwin.

A third category of relevant prior art does not actually have springs in the soles. Rather, these patents do provide means for the wearer to flex their metatarsal joint and push off their toe. U.S. Patent # 4,400,894 of Erlich, U.S. Patent # 5,926,975 of Goodman, and U.S. Patent # 5,384,973 of Lyden all feature a narrowing of a conventional, solid sole under the metatarsal joint, and there are many other examples of this solution. U.S. Patent # 6,079,126 of Olszewski uses the just-mentioned "narrowing" solution as well as another solution where a conventional, solid sole is split and the upper section lifts with the wearer's heel. A U.S. Patent # 5,282,325 of Beyl also teaches a split sole with a torsion spring in the heel.

The current patent also provides for the wearer to flex his metatarsal joint and push off his toe -- in a variety of ways. However, the sole structure of the space shoe is distinct -- in that it comprises a linkage between plates, instead of the conventional, solid sole of the just-mentioned prior art. That is, even though the "toe-flex" function is the same, the structure and designs of the current patent are quite different and novel, and the general idea of a means for toe-flexing is old in the art.

With reference to the second embodiment of the invention, namely the bow shoe, the above improvements (S1, S2, and S3) still apply -- along with some additional improvements labeled "B" for bow shoe. (B1) The bow shoe minimizes weight at the foot for improved energy efficiency. (B2) It uses bow springs to achieve a constant force curve. (B3) It permits optimally few, long, and light bow springs. (B4) It provides for optimal stability by minimizing the unweighted sole thickness.

The fourth category of "springs in soles" prior art has a spring and suspension mechanism in the heel. An example is U.S. Patent # 6,115,942 of Paradis with a bow spring. Improvements (S1, S2, B3, and B4) apply to this patent. Another example is U.S. Patent #6,131,309 of Walsh with improvements (S1-S3 and B1, B3 and B4) applicable. The fifth category has a curved ground support hingeably connected in front and in back to the shoe and a single spring in the center. An example is UK Patent # GB2,179,235 of Waldron. Improvements (S1-S3 and B1-B4) apply to this category. The sixth category of has a linkage to constrain a compressible sole as a spring stores only heel impact energy. Examples include U.S. Patent #4,534,124 of Schnell, U.S. Patent #5,896,679 of Baldwin, U.S. Patent #5,701,685 of Pezza, U.S. Patent # 1,613,538 of Schad, U.S. Patent # 5,464,380 of Ikeda, U.S. Patent # 3,205,596 of Hoffmeister, U.S. Patent #

6,553,692 of Chung, and U.S. Patent # 6,115,943 of Gyr

Improvements (S2, S3 and B1-B4) apply to Schnell and Pezza. Improvements (S1-S3 and B1-B4) apply to Baldwin. Improvements (S1-S3) apply to Schad. Improvements (S1 and S3) apply to Ikeda, Hoffmeister, and Chung. Ikeda does use side-ways-opening hinged links to constrain longitudinal relative plate motion, but in a manner distinct from the current sole linkage. Hoffmeister uses multiple, connected diamond links to prevent sole tilting, but his linkage requires that the upper and lower hinges, which bear considerable weight, slide in slots. This disadvantage is overcome in the current sole linkage which does not have weight-bearing sliding bearings, which fact makes it a distinct linkage from that of Hoffmeister. Chung uses lateral "x" hinged links which again present difficulties with weighted sliding on the plates of the top and bottom ends of the links, and Chung's linkage both is distinct from the current sole linkage and is confined to the heel region. Gyr does disclose a parallelogram linkage, but only in the heel and without loading the linkage so as to achieve an optimal or constant force curve. Also, the relative longitudinal motion of the bottom of Gyr's linkage with respect to the forefoot will cause significant friction losses.

The seventh category uses a linkage to connect the toe of a shoe to the mid-section of a bow spring, the bottom of which contacts the ground. A commercial product of ALANSPORTartikel, address: GmbH Grafratherstrasse 53, 82288 Kottgeisering / Germany, marketed under the brand name of "Powerskip" and referenced by their website, <http://www.powerskip.de>, is the only example of this category. Improvement (S3) applies because the force curve is not as constant as for an axially-loaded bow spring, and improvements B3 and B4 apply. The most notable improvement is (B2) because the foot of the wearer of "Powerskip" is a substantial distance above the ground even when the bow spring is fully compressed.

Finally, with regard to the flex-rigger of the current patent for prevention of sprained ankles, U.S. Patent # 5,875,569 of Dupree discloses a small tab on the outside of a sole, which does not flex forward and backward to avoid tripping and which does not project as far to the side (given more protection) as is made possible by the flexing action of the flex-rigger. With regard to the leg-braced back-heel of the current patent, U.S. Patent # 4,238,894 of Evans discloses a back extension which does not have the leg brace of the current patent for prevention of hyper plantar flexion.

Summary

With reference to the space shoe, in both space shoe and bow-shoe embodiments, the key feature is a compressible sole comprising a sole linkage which constrains the upper shoe plate not to tilt as it moves vertically up and down with respect to the ground plate. Another feature is a push-off means which allows the wearer to freely push off her toe. Another feature is that a minimal number of springs and stops (even one) of any kind can be used (without need of a spring guide). These springs and stops can easily be modular and replaceable to fit the performance

requirements of an individual for walking and running. Another feature is a back-flexing outrigger, called herein a "flex-rigger," to prevent sprained ankles; the flex-rigger can be used not only with the space shoes, but also as a retrofit or an integral part of conventional shoes or boots. Another feature is a curved extension extending backward from the bottom of the sole heel; this is called herein a "leg-braced back-heel." The back-heel minimizes the deceleration of the user's center of mass at heel-strike by reducing the effective angle (backward, off-vertical) of the leg support, and the leg brace prevents hyper plantar flexion at heel strike. The back-heel can also as a retrofit or an integral part of conventional shoes or boots.

The advantages of the space shoe include: the sole can be very thick (2-6 inches) thereby make a wearer taller and enhancing her stride; even when the sole is thick, the wearer's foot rolls over from heel to toe naturally; the wearer pushes off naturally; the shoe is energy-efficient in that it returns maximum impact energy (due to both heel impact and toe impact) to the wearer during thrust at toe-off when it is best utilized; the shoe is light-weight and cheap to manufacture; there are spring systems which provide for a constant force curve, instead of a linear force curve, thereby permitting faster running for a given maximum force, thereby reducing impact injuries; since the surface in contact with the foot is very thin, it is easy to ventilate the foot; this foot-contact can be shaped as a foot orthotic; and the sole thickness (1" to > 6") and area can easily be changed due to the modular construction.

A critical insight motivating the (full energy return) sole linkage is that, in order for heel impact energy to efficiently propel the runner up and forward, it must act through the runner's toe during the latter part of toe-off. The sole linkage controls tilting of the compressible sole, and this constraint also results in heel impact energy to be returned at toe-off. Another performance enhancement in terms of energy efficiency results from the fact that the sole linkage can be made very thick. This allows the wearer to minimize knee flexion in both walking and running. With reference to the bow-shoe embodiment only, one key feature is a bow spring to achieve a constant spring force curve which doubles the potential energy storage in a sole of a given thickness. Another key feature is a suspension system in which a bow spring is loaded by full foot impact – both by the heel and the toe. This suspension system permits the location the bow spring above the foot at the shin or thigh level to minimize the device weight at foot level – thereby improving energy efficiency. Also, the use of an linkage allows the sole components to be optimally (skeletal) light. Another improvement is related to the constant force curve, referred to as a buckling curve, achievable with bow springs. This allows a safe threshold force level to be set, and twice as much energy can be stored for a given sole thickness as with a linear spring. Also, bow springs can be more than 90% energy efficient. A consequence of the anti-tilt feature inherent in the sole linkage is that a spring located anywhere in the sole resists sole compression at both the toe section and the heel section. This means that one or two springs or stops suffice, and modular design makes it a simple matter to change springs to tune the bow shoe to an individual's weight and gait and to change shoe and ground plates for different size feet. Another improvement is that the bow shoe provides for optimal stability by minimizing the unweighted

sole thickness -- by virtue of the remote location of the bow spring above the foot level. That is, since the bow springs are not located in the sole, the sole can be fully compressed. Finally, the sole linkage can be manufactured very cheaply.

Other applications include a spring/foot component of a walking/running brace or of a backpack-supporting brace for walking and running and for use with prostheses and robotics.

Brief Description of the Drawings

Figure 1 shows views of the main invention, a non-tilting compressible structure called p-diamond.

Figure 2 shows a side view of a p-diamond linkage indicating how lengthwise springs with the proper hard force curve can be used to achieve a constant force curve, as well as mirrored and vertically stacked configurations of p-diamonds.

Figure 3 shows schematic side and front views of the space shoe showing the compressible p-diamond sole.

Figure 4 is a schematic side view of the p-diamond sole with necked link hinges.

Figure 5 is a schematic side view of examples of necked link hinges.

Figure 6 shows means to attach a foot to the space shoe and a schematic side view of the space shoe showing elastic walls.

Figure 7 is a schematic side view of the space shoe showing an elevated heel on the push-off frame and a schematic front view of the space shoe showing various profiles for the p-diamond sole.

Figure 8 shows a schematic front view of the space shoe showing back-flexing outriggers to prevent sprained ankles and a schematic top view of the space shoe showing various back-flexing outriggers to prevent sprained ankles.

Figure 9 is a schematic side view of the space shoe showing various designs of push-off frames.

Figure 10 is a schematic top view of the space shoe showing a delayed heel-lifter in the spring system to lift the runner's heel during the latter part of toe-off.

Figure 11 shows an application of the p-diamond invention to running braces.

Figure 12 shows an application of the p-diamond invention to leg prostheses

Figure 13 is a schematic side view of the bow shoe embodiment, with a shin-level bow spring and a compressible p-diamond sole.

Figure 13 is a schematic front view of the bow shoe embodiment, with a shin-level bow spring and a compressible p-diamond sole.

Figure 15 shows side views of a p-linkage and a simplified presentation called herein a "line-link view" where lines represent links.

Figure 16 shows line-link side views of a 2p-linkage, first with symmetric link lengths and second with asymmetric link lengths.

Figure 17 shows line-link side views of a one-spring leaf linkage and a two-spring leaf linkage.

Figure 18 shows a line-link side view of a p-diamond and a half-height p-diamond.

Figure 19 shows line-link side views other configurations of the p-diamond.

Detailed Description of the Invention

Figure 1 shows views of the main invention, a non-tilting compressible structure called p-diamond 11. Side-view Figures 1a and 1b show p-diamond 11 expanded and compressed. Figure 1c is a front view and Figure 1d is a top view. P-diamond 11 comprises one or more (two here) p-diamond linkages 9, rigidly connected by cross beams 13, and optionally covered by cover plates 21 on the top and the bottom. P-diamond linkage 9 comprises four diamond links 10, one top length link 23, one center length link 24, one bottom length link 25, and two end links 14 – all of which are hingeably connected in the depicted configuration by link hinges 16. Top length link 23 and bottom length 25 optionally extend beyond link hinges 16 on either end, but the functional parts for p-diamond linkage 9, that cause the critical motion constraint of p-diamond linkage 9 to move with only one degree of freedom, requires only the parts between the link hinges 16. The other required constraint is that mid-link front vertex guide 71, rigidly attached to center length link 24 and extending horizontally to the left in Figure 1b, guides front mid link hinge 16 to follow a horizontal path as p-diamond linkage 9 collapses and expands. That is, this guided constraint ensures that center length link 24 stays precisely in the center between top length link 23 and bottom length link 25. As long as this center position is maintained the bearing force of front mid link hinge 16 on mid-link front vertex guide 71 is minimal. This minimal guiding force is a key advantage of p-diamond linkage 9 over linkages found in the prior art.

In total, all these links form an 8-bar linkage which constrains upper frame 6 to move vertically (with no tilting) with respect to lower frame 4. In this embodiment, upper frame 6 comprises two top length links 23, cross beams 13 at the top, and cover plate 21 at the top. Likewise, lower frame 4 comprises two bottom length links 25, cross beams 13 at the bottom, and cover plate 21 at the bottom.

Figure 1 a shows lengthwise spring 57 and pre-bow spring 51 which resist any compression force on p-diamond 11; vertical springs 19 also resist external compression. An external compression force can be exerted at any point on and between the areas of upper frame 6 and lower frame 4. At the same time an expansion force can be exerted at any point on and between the areas of upper frame 6 and lower frame 4. Even though the compressive and expansive forces are not located in the same place, upper frame 6 will not tilt with respect to lower frame 4. This is the key feature of the p-diamond invention. The term “p-diamond” refers to the fact that the linkage comprises overlapping parallelograms and diamonds. The value of the invention is that this is the simplest structure using only hinges and a minimal-force guide to

achieve this particular constraint of one degree of motion, and hinges are the cheapest, lightest, most robust means to achieve guiding of spring mechanisms in many applications.

Figure 1 actually depicts several variations of spring systems. Figure 1a shows lengthwise spring 57 (helical) acting between 1) the center cross bar 17 located at the cross beam at link hinge 16 connecting the outside (left) pair of diamond links 10 and 2) the center cross bar 17 between adjacent center length links 24. Note this second location could be anywhere along center length links 24. Diamond tether 59 limits the amount of compression. Figure 1b shows the alternative of a generic vertical spring 19 resisting compression and stop 44 limiting compression. These can be helical springs 48 or spiral helical springs 50 (which can compress to the wire thickness).

Figure 1c, the front view, shows the locations of vertical spring 19 and stop 44, located in this case between the adjacent p-diamond linkages 9. In dashed lines, the location of center cross bar 17 is shown – for when a lengthwise spring 57 is used. Top view Figure 1d shows a pre-bent bow 51 acting (in tension to resist compression) between two center cross bars 17. Also shown here is how cover plate 21 covers the frame work comprising top length link 23 and cross beams 13. Cover plate 21 is optional and upper frame 6 or lower frame 4 could alternatively be anything from a simple plate to a molded and highly optimized covered, pocketed framework.

It is understood that any type of spring deemed useful can be used, and these may act in compression or tension between vertices or locations along links. Since p-diamond sole 8 guides upper frame 6 to not tilt or move sideways with respect to lower frame 4, a minimal numbers or vertical springs, even one, can be used, and the both the heel and toe impact energy are returned through the wearer's toe during the latter part of toe-off. Notably, single or multiple springs and stops of any shape can be used to achieve any desired travel or compression from very little to the entire thickness of the unweighted sole. This full thickness may be only an inch or it may be six inches or more. Other spring options include tapered serpentine springs and air springs. By tapering a bow spring in a particular manner, it is possible to get just the right "hard" force curve where hard means the curve increases faster than a linear spring.

Figure 3a shows a side view of a p-diamond linkage indicating how lengthwise springs with the proper hard force curve can be used to achieve a constant force curve. The vertical force exerted by lengthwise spring 57 can be expressed as the product of the mechanical advantage, MA, due to the diamond structure, times the horizontal force, F_x , exerted by lengthwise spring 57. If the length of diamond link 10 is L_d and the spring rate is K , then $F_y = MA * K * x$ where x is the change in length of lengthwise spring 57 as each diamond link 10 rotates an angle, a , from vertical – assuming a linear spring. Also, $MA = (\cos(a)/\sin(a))$ and $x = L_d * \sin(a)$. Thus, $F_y = L_d * K * \cos(a)$. By using a tension spring proportional to $(1/\cos(a))$, one can achieve a constant force curve in which F_y remains approximately constant as p-diamond 9 compresses under a load. Proper construction of a tapered pre-bent bow 51 (Figure 1d) will provide a hard curve which can be designed to give the desired force curve.

Figures 3b and 3c show side views of mirrored and vertically stacked configurations of p-diamonds. In Figure 3b, mirrored p-diamond 26 comprises two mirrored p-diamonds which share both diamond links 10 and top, center and bottom links length links 23, 24, and 25. In Figure 3c, vertically stacked p-diamond 27 basically has an upper p-diamond linkage 9 which shares its bottom length link 25 with the top length link 23 of the p-diamond linkage below it. Here, a single bow spring 52 can be guided and compressed by vertically stacked p-diamond 27. Two or more stages (stacked units) could be used with vertically stacked p-diamond 27.

The primary application of the p-diamond invention is space shoe 2 which is the first embodiment of the space shoe. All initial space shoe embodiments use p-diamond 11 of Figure 1 and all of the features and benefits of this structure discussed above apply. That is, the basic components and functions of the p-diamond are the same. Later other linkages will be shown which provide less constraint, but which can still be functional.

Neither the spring system nor mid-link front vertex guide 71 are shown sometimes for ease of viewing, e.g. in Figure 3 a, b, c, but it should be understood that these are required in an actual model. Figures 3a, 3b, and 3c are schematic side views and Figure 3d is a schematic front view of the first embodiment of a space shoe. Figure 3a shows heel-strike, Figure 3b shows mid-stance with p-diamond sole 8 compressed, and Figure 3c shows toe-off. Wearer's foot 1 is confined to the front section of upper frame 6 and to push-off frame 18 by shoe straps 22.

Push-off frame 18 is one example of a push-off means, which achieves the following functions. (1) It always allows the wearer to flex her metatarsal joint to lift her heel and push off her toe at toe off. (2) It optionally may prevent the wearer's toe from twisting out of the foot attachment means at the toe section by constraining the rear part of the wearer's foot to lift vertically with respect to the rear part of upper frame 6. (3) It optionally may lift the rear part of upper frame 6 to contact the wearer's heel during swing phase. Push-off frame 18 may extend around the wearer's heel a variable distance above the bottom of the heel or it may extend only part way back toward the heel. It may also be a plate located at the bottom of the wearer's heel and mid-foot, which plate may have holes or voids of variable size.

Figure 3d shows the front view of p-diamond sole 8, and it is entirely equivalent to Figure 1c except that the runner's foot 1 is now attached to cover plate 21 by shoe straps 22. P-diamond sole 8 corresponds to p-diamond 11 in Figure 1, comprising the same linkage elements. Here, vertical spring 19 and stop 44 are shown. Optional push-off frame 18 is pivotally connected to upper frame 6 below or on the outsides of the location of the metatarsal joint of wearer's foot 1—thereby allowing the wearer to push off naturally at toe-off. Lower frame 4 may incorporate ground plate rocker 30 (shown in place of bottom length link 25 in Figure 3b) and ground plate curved toe 32 to optimize the energy return of space shoe 2 (by permitting greater forward tilt at toe-off). Also, cover plate 21 need not cover the entire area of lower frame 4; it could simply be a durable material such as vibram or hard rubber bonded to the length and cross beam elements of lower frame 4.

Figure 4 shows schematic side views of a p-diamond linkage 9 using necked pivots as necked link hinges 15. Figure 4a shows p-diamond linkage 9 fully expanded, and Figure 4b shows p-diamond linkage 9 partially compressed. Figure 5a shows a blow-up of the diamond 4-bar linkage made up of the four diamond links 10 which are interconnected by necked link hinges 15, which flex easily by virtue of having a small cross section and by virtue of being made of a compliant material. Necked-pivot stops 29 can also be used to limit compression. Necked pivots 15 for rear links 14 and toe hinge 20 are also shown in Figure 5b. Notably, p-diamond sole 8 can be cheaply and easily fabricated by stamp cutting out of a sheet or by using mold technology. Figure 5c shows another method for a "necked-down" hinge comprising elastic strip 63 bonded to link beam 65; or, in Figure 8d, necked tube (which might have a square cross section) is another possibility. The flexible material might be fiber composites or nickel-titanium alloys (Nitinol) known to have high duty cycles for flexing.

Figures 6a and 6b show means to attach a foot to the space shoe. Figure 6a shows one of many possible strapping arrangements to for shoe straps 22 to attach pre-existing shoe 34 to the front section of upper frame 6 and to the rear section of push-off frame 18 via buckles 36. Figure 6b shows toe cup 38 and heel cup 40 which can be used with or without a pre-existing shoe for the same attachment and which may incorporate further shoe straps 22. Heel bumper 39 and toe bumper 37 can also be optionally used to confine pre-existing shoe 34 to the space shoe. The rest of the sole of the space shoe is not shown here. In this instance, push-off frame 18 is located at the level of the bottom of pre-existing shoe 34 or wearer's foot 1, and it may extend a variable distance underneath pre-existing shoe 34 or wearer's foot 1. Also, plate cover 21 here is shaped like an orthotic to conform to and give arch support to the bottom of runner's foot 1. Plate cover 21 could optionally be perforated to improve foot ventilation.

Figures 6c and 6d are schematic front and side views of the space shoe showing elastic walls 46. These are attached to and surround p-diamond sole 8, and they may be sufficiently elastic not to wrinkle even when p-diamond sole 8 is fully compressed. These could be elastic or transparent. And, they could be used to keep dirt out of p-diamond sole 8 or to make a fashion statement.

Figure 7a is a side view of the space shoe showing elevated heel 58 which is now an integral part of push-off frame 18, and showing back-heel 28. This elevated variation is a basis for high heels or elevator shoes. The improvement here is that push-off is allowed due to push-off frame 18 and due to the fact that a substantial part of the increase in height of the wearer of this space shoe is due to the thickness of p-diamond sole 8. Thus, the height of elevated heel does not need to be as large to make a person significantly taller. Another advantage is that this space shoe is much more comfortable, e.g. than a high heel, since there is ample arch support, and the wearer's weight is distributed over the entire foot. The heel elevation can also be realized by building up the heel part of upper frame 6, or it can be realized by building up both a push-off frame (18) and upper frame 6. Back-heel 28 has a circular shape with a radius approximately equal to the length of the runner's leg. Its purpose is to reduce the angle back away from vertical

at which the effective leg force acts (defined by the line between the runner's center of mass and the point of contact between back-heel 28 and the ground) – thereby reducing the deceleration of the runner's center of mass during heel strike. Padded back-heel leg brace 95 distinguishes this back heel from prior art in that it prevents hyper plantar flexion at the onset of heel strike. A similar extension and brace can be used in the front to extend stride safely. Another possibility is to retrofit conventional shoes with back-heels 28.

Figures 7b and 7c show schematic front views of the space shoe with various profiles for p-diamond sole 8. Figure 7b shows hourglass linkage 62, and Figure 7c shows pedestal linkage 60. The purpose of these variations is to make a more attractive style which lends itself to use with high heels. Elastic walls 46 also improve the appearance of the shoe.

Figure 8a is a schematic front view and Figure 8d is schematic top view of the space shoe showing back-flexing outriggers called flex-riggers 81 to prevent sprained ankles. These flex-riggers 81 all are stiff to prevent rotating upwards, but they flex backward easily to prevent the wearer from tripping. For example, hinged flex-rigger plungers 80 are hingeably connected to lower frame 4 so that they can be swept back easily if they hit the other foot or an impediment on the ground. However, they resist “roll” rotation of lower frame 4 about a front-back axis, and, hence, they prevent twisting of the wearer's ankle. That is, they flex easily back and forward, but not up and down. Flex-rigger spring 84 weakly biases outrigger 80 to stick out to the side. Another feature, as demonstrated by the plunger feature in hinged flex-rigger plunger 80, is that a flex-rigger can be designed to give when pushed directly inward from the side, so as to not damage an object or a person next to the user. Other means such as pleated frame 83 could also be used to give in toward the shoe as well as backward and forward – but not up since the top and bottom sides would not be pleated. Flex-rigger wands 88 are also shown can also be used. Necked flex-rigger frames 86 with necked link hinges 15 can be used provided their depth is large enough to prevent up/down motion. Necked link hinges 15 permit front/back motion. These flex-riggers 81 can be used just as well with conventional shoes in which case they are attached to the shoe sole. They could either be incorporated in the sole as manufactured, or they could be fixably attached to retrofit the sole of a pre-existing shoe. The methods of attachment of flex-rigger 81 to lower frame 4 (or to shoe sole 75 of pre-existing shoe 34 in Figure 7a) would include, but not be limited to, bonding, riveting, or screwing.

In addition, flex-rigger 81 could manufactured as an integral part of the soles for new types of conventional shoes or for lower frame 4. For retrofitting, Figures 8b shows a front view of a shoe retrofit design with top bar 85 rigidly attached to flex-rigger 81, for structural, anti-tilting strength, and using snap pins 89 to snap onto pre-existing shoe 85. Figure 8c shows a front view of another retrofit design using under bands 91 which keep flex-rigger 81 tight on pre-existing shoe 34, along with sole screws 87.

Figure 9 is a schematic side view of the space shoe showing various designs of push-off frames 18. Figure 18a shows push-off frame 18 located at a level above the shoe sole 75 and extended around the back of pre-existing shoe 34. Optional top brace 90 and optional bottom

brace 92 may connect and brace the side elements of push-off frame 18 as also shown in the top view, Figure 18f. Figures 18b and 18e show side and top views of part-way push-off frame 94 which extends only part way along the rear section of pre-existing shoe 34. The top view shows optional frame voids 100 which lighten the weight when push-off frame may extend below pre-existing shoe 34. Figure 18c and 18d show side and top views of bottom push-off frame 98 which extends below pre-existing shoe 34. The top view shows optional holes 96 and frame voids 100 which lighten the weight and provide ventilation of the wearer's foot in case no pre-existing shoe is used.

Figure 10 is a schematic top view of the space shoe showing delayed heel-lifter 140 in the spring system to lift the runner's heel during the latter part of toe-off. The purpose is to delay the action of an impact-absorbing spring until the latter part of toe-off, and this idea can be used with conventional shoes or boots, in general. The additional benefit is the calf muscle action to plantar flex the ankle joint (in toe-off) is assisted by delayed heel lifter, and better running economy can, in principle, be achieved. Heel-lifter bow 142 is pivotly connected to lower frame 6 and slidingly connected within pawl/bow pivot guide 160, which is housed in heel-lifter guide frame 144, rigidly attached to lower frame 4. Also slidingly connected within heel-lifter guide frame 144 are upper frame catch 148 and push-off ratchet 150 – both of which are biased upward by elastic bands 156 via band posts 158. P-diamond linkage is shown in Figures 10a and 10c, but not shown in Figures 10b and 10d due to lack of space. The spring systems shown in other figures can be used. Heel-lifter bow 142 acts in addition to those other springs.

Figure 10a depicts the time of heel contact. Heel-lifter bow 142 (another type of spring could be used) is loaded as upper frame catch 148 is caught by two-way pawl (biased in this direction by a simple spring not shown), and upper frame cord 152 is pulled down by upper frame 4. Figure 10b shows full impact. Figure 10c shows the early part of heel lift when it is too early for heel-lifter bow to act effectively. Until this chosen angle of lift of push-off frame 18, upper frame catch has been engaged, preventing heel-lifter bow 142 from straightening. Bar-bias-bar 162, pivotly connected to push-off frame 18 and constrained within with an inclined step in width, will serve to bias two-way pawl 146 to disengage upper frame catch 148 and engage push-off ratchet 150 at this chosen angle as shown in Figure 10e. Then, heel-lifter bow 142 is free to lift push-off frame 18 via push-off cord 154 during the latter part of toe-off. During swing phase the device returns to the configuration of Figure 10a by virtue of heel hugger 101 of Figures 19 or 20 and the not-shown spring to bias two-way pawl counterclockwise.

The next embodiment or application of the p-diamond invention is for use with running braces. The p-diamond provides the spring and the brace foot so that the action of the running brace is very similar to the action of the runner's leg and foot. Figure 11a shows a front view and Figure 11b a side view of front/back brace leg 650 in which the pelvic coupling is made directly behind and in front of the runner's ischial tuberosity (buttock) rather on the side of the hip. Front hip pivot 678 is pivotly attached to harness 683 directly above runner's leg 676 in front, and back hip pivot 680 is pivotly attached to harness 683 directly above runner's leg 676 in back. Front and

back -- hip pivots 678 and 680, knee pivots 660 and 662, and thigh links 652 and 654-- and knee cross link 674 form a four-bar system. Front and back -- ankle pivots 670 and 672, knee pivots 660 and 662, and ankle links 670 and 672 -- and knee cross link 674 form another four-bar system -- with knee pivots 660 and 662 and knee cross link 674 being shared between these two four-bar systems. The runner's pelvis and/or harness 683 act as the cross link at the hip level for the upper four-bar system, and top length link 23 acts as the cross link at the foot level for the lower four-bar system. These two four-bar systems are sufficiently distant from runner's leg 676 throughout a stride as to not interfere with the same. Back hydraulic knee lock 664 is rotatably connected to a back thigh link 654 and back tibia link 668 so that when a foot trigger (not shown, but straightforward to implement for one of ordinary skill in the art) locks back hydraulic knee lock 664 as foot strike, flexion about back knee pivot 662 is locked. Another knee lock could be used for front knee pivot 660, but this is not necessary because back knee pivot 662 is shared by both four-bar systems. That is, when back knee pivot 662 is locked, both the above-mentioned top and bottom four-bar systems are converted to three-bar systems, and both structures are locked. Folding of the upper and lower four-bar systems with respect to each other is realized as the runner's weight leans forward. This folding can be enhanced by tethering front and back knee pivots 660 and 662 to the runner's knee. The runner's foot can now be coupled to bottom length link 25 at its front, thereby permitting heel lift during toe-off.

Note the elements of the p-diamond linkage 9 are the same as in Figure 1. The key difference here is that the runner's foot 1 is now located between the two p-diamond linkages 9, which, in turn, are rigidly connected in the front and the back by brace cross bars 682. In this way, front/back brace leg 650 supports the runner's weight in parallel with the runner's leg. Also, lengthwise spring 57 can now be positioned to be outside of p-diamond linkages 9 and to be curving upward, the runner's foot is not directly above. Finally, if the one or both knee pivots in Figure 11 are constrained from hyper-extending (as is commonly done with above-knee prostheses), a separate knee lock, such as back hydraulic knee lock 664, can be eliminated since the "constrained hyper-extension knee lock" naturally locks at heel-strike and naturally starts folding just before toe-off. Having a separate knee lock allows the runner to run uphill or to land with a more substantially pre-bent leg, but this capability is not needed in many applications. This is even more true for a running brace than for above-knee prostheses, since the runner's leg is there to prevent a fall.

Figure 11c shows the option of front/back pack extension 690 for comfortable and optimal pack load support. The running/walking brace shown is front/back brace leg 650 of Figure 38. Front pack frame 692 is pivotly attached to the top front of front/back brace leg 650 by pack-frame pivot 698, and back pack frame 694 is pivotly attached to the top back of front/back brace leg 650 by pack-frame pivot 698. Pack straps 696 attach front pack 700 to front pack frame 692, and back pack 702 to back pack frame 694. If the brace legs were not supporting the pack weight, there would be an uncomfortably high load on the runner's shoulders. Also, the front parts of front/back pack extension 690 can be eliminated, in which case runner 1 must lean

forward at the waist to balance the pack. Note that one option is for harness 683 to not couple to the pelvic region of runner 701 in a supportive manner; in this case, front/back brace leg 650 simply supports the packload. This eliminates the difficult problem of coupling to the runner and makes for an easier product.

Figure 12 (12a a front view and 12b a side view) shows another application of the p-diamond invention, namely p-diamond prosthesis 130. Pylon 120 would be attached at its top to a conventional below-knee socket engaging the stump of an amputee. Pylon 120 is rigidly attached to p-diamond sole 8 which is detailed in earlier figures. Since there is no runner's foot in this application, lengthwise springs 57 can be moved closer to the center. Also, brace cross bar 682 can be made narrower on the top, at the level of top length link 23, to allow a bow version of lengthwise spring 57 to bow upward without interference. Figure 12c shows a front view or another variation of p-diamond prosthesis 130. Here, p-diamond linkage 9 is much taller (by virtue of diamond links 10 and end links 14 being much longer). The side view would be equivalent to Figure 12b except for this tall feature. Now, in Figure 12c, prosthetic bow spring 124 can be oriented vertically, pushing directly and vertically between brace cross bars 682 at the top and bottom of p-diamond sole 8. Prosthetic bow spring 124 is pivotly connected to brace cross bars 682 via bow spring pivots 126. Note, that vertically stacked p-diamond 27 of Figure 2c can alternatively be used in the variation of Figure 12c. Also, the p-diamond invention could just as well be used at the thigh level of an above-knee prostheses. Finally, the p-diamond can be used with active and passive (using springs), or combinations of the two, to aid in actuation of any limb or actuated element, such as arms, legs, necks, torsos, etc.

Another application of the p-diamond invention is bow shoe 202 shown in Figure 13 (a side view and Figure 14 a front view). It combines shin-level bow 240 and compressible p-diamond sole 8. All details such as the various springs are not shown here, but any of the features of the space shoe discussed earlier can be incorporated into the bow shoe. Figure 13a shows heel-strike, Figure 13b shows mid-stance with p-diamond sole 8 compressed, and Figure 13c shows toe-off. Here, p-diamond sole 8 is equivalent to that shown in Figure 3. Ankle-pivot supports 226 are rigidly attached on either side to lower frame 4 – to support ankle-pivot housings 234 and ankle pivots 232. Stirrups 236 are pivotly connected to ankle-pivot support 226 by ankle pivot 232, and they prevent interference of the bow support section with runner's shin 3. Bow 240 is pivotly attached to stirrup 236 via lower bow hinge 242, and bow guide 238 is rigidly attached to stirrup 236. The top of bow 240 is pivotly attached to bow guide 238.

Cords 228 attach to a front and a rear side point on upper frame 6 at equal distances in front of and behind ankle-pivot support 226. Cords 228 extend up to be guided through the center of ankle-pivot housing 234 so as to minimize any torque exerted by cord 228 on bow guide 238 about ankle pivot 232. Cords 228, four in all – from the front and rear on both sides, extend further up to attach to upper bow hinge 244. Accordingly, when runner's foot 1 pushes down on upper frame 6 during foot-strike, bow 240 is loaded via cords 228. Since rear and front cords 228 are symmetrically positioned about ankle-pivot support 228 and since p-diamond sole 8

forces vertical compression, bow 240 is loaded by either or both heel and toe impact. This ensures that the full impact energy is returned through the runner's toe at toe-off. To keep bow 240 from flopping about, it is attached to shin strap 246 via shin slider 248 which is slidingly connected to the upper part of the telescoping bow guide 238.

There are several embodiments of a "full energy return" linkage other than the p-diamond linkage. These do not provide as full a constraint on the relative motion of the top and bottom sole plates as the p-diamond linkage, but they still have useful functionality for full energy return in walking or running. Most importantly, full energy return means that all heel and forefoot impact energy (neglecting friction losses) is returned for thrust, optimally in the latter part of toe-off. The signature feature of these embodiments is that they extend over the full or major length of the foot. Also, all of the features that apply to use of p-diamond linkage 9, such as push-off frame 18, apply to these other embodiments.

The next embodiment, shown in Figure 15, is p-linkage 500. Figure 15a shows the four links that form a parallelogram (hence, the "p"), namely top p-link 501, bottom p-link 502, and two vertical p-links 503. Diagonal spring 505 stores the energy of impact and compression, and forces the later expansion of p-linkage 500. Any of these linkages can be oriented backwards or forwards, but if the forward direction is to the left of Figure 15, top p-link moves backward with respect to bottom p-link 502 during impact. This has the advantage of reducing the effective line of force angle of the leg on the runner's center of mass, thereby reducing deceleration in the heel-strike period. Also, the opposite relative motion occurs in toe-off accelerating the runner forward more rapidly. Later, variations in the p-diamond configuration will be shown to achieve this same "slingshot" effect. It remains to be seen if this longitudinal relative motion is too large, because it cannot be precisely controlled as is the case for the next embodiments. Figure 15b shows a line-link side view of p-linkage 500. This simplified view will be used to illustrate the various alternative configurations because the essence of their functionality is thereby more easily seen. Figure 15c shows arbitrary length 4-link linkage 510, which recognizes that there may be good design reasons for the lengths of a 4-link linkage may have the somewhat arbitrary values of arbitrary length links 507. The main point of this patent is that 4-link linkages permit control of the motion and orientation of a runner's foot. Exact values or symmetries may not be necessary or even recommended.

Figure 16 shows a third linkage embodiment, 2-p linkage 511. This utilizes diagonal springs 505, and other springs such as vertical spring 19 could also be used. Here, the relative longitudinal motion of the upper and lower links can be precisely controlled (about zero), either with different forces for the upper and lower diagonal springs 505, e.g., asymmetric diagonal spring 518, or by using asymmetric vertical p-link 516 (of different length). Both of these control strategies are shown in Figure 16b of asymmetric 2-p linkage 518.

Figure 17a shows one-spring tilting linkage 520 which uses link-to-plate support 523 to minimize the maximum tilt of the top sole plate. One-spring 524 stores impact energy via short links 521. Figure 17b shows two-spring tilting linkage 530 which does not require link-to-plate

support 523. Upper and lower springs 534 and 535 store impact energy as two-spring short links 531 and two-spring long links 532 rotate, pulling them against the ends of two-spring 533. The linkage of Figure 17 do not belong with or compare favorably with the other linkages herein because the left side of the sole does not compress any significant distance. These are shown to emphasize inherent superiority of the parallelogram based linkages of this invention.

Figures 18b (side view) and 18b (front view) show a variation on p-diamond sole 8 wherein space shoe 2 rests in a recessed structure, namely half-height plate 540 supported by half-height hangars 542 from the tops of p-diamond linkage 9 on either side of space shoe 2. This feature reduces the height of the runner's foot above ground, as compared with the design of Figure 18a, and this feature can be used with of the linkage embodiment of this invention. It does, however, restrict the use of a pre-bent bow 51 to only the lower half of the height of p-diamond linkage 9. Normally, bows can be used in both halves.

Figure 19 shows variations on the configuration of p-diamond linkage 9, namely asymmetric p-diamond linkage 545. Figure 19a shows longer front diamond links 546, and Figure 19b shows short link 521 and long link 522, which can be used to control the longitudinal relative travel.

In summary, this invention includes several "full energy return" linkages, all of which extend to full length of the shoe and all of which constrain full sole length compression so that springs can return full impact energy at toe-off. Note that the orientation of any of the "full energy return" linkages of this invention could be rotated ninety degrees about the vertical axis so that the vertical links open laterally rather than longitudinally, provided that the effective "width" of this linkage be the full length of the shoe sole. For example, in Figure 16a, the orientation could be such that the direction into the paper for the right foot is the forward direction. The vertical p-links 503 on the right are now protruding toward the outside of the right foot, and the "width" of the linkage must be the sole length to achieve full energy return. In other words, the links would have to be that sole-length wide or several linkages could be arrayed laterally along the sole length and structurally connected to act as one. It is unlikely that this orientation would be favorable, because the spring length would be shorter, and that is probably a design liability.

CLAIMS

1. A full energy return shoe sole for walking, running, and jumping comprising a top sole plate and a bottom sole plate, one or more full energy return linkages each comprising four or more links hingeably interconnected at vertices,

one or more springs acting between said links, and

a foot attachment means to attach said p-diamond sole to the foot of a wearer, wherein at least one of said links is rigidly attached to said top sole and at least one other of said links is rigidly attached to said bottom sole, wherein said full energy return linkage provides a full energy return constraint for said top plate to remain aligned substantially parallel to said bottom plate along their full lengths throughout the compression and expansion during the stance period, wherein said springs absorb the full impact energy imparted on the ground along the entire length and width of said foot during the impact period of stance and said springs return said full impact energy during the thrust period to impel said wearer forward and upward, wherein any compression force between any portions of said top sole plate and said bottom sole plate causes all impact energy to be stored in said springs until the toe-off period, wherein the heel impact energy is not dissipated by being released prematurely, before the toe-off period.

2. The full energy return shoe sole of claim 1 wherein said full energy return linkage can be combination linkage of said full energy return linkage with additional links, provided said full energy return constraint is provided by said combination linkage, wherein said combination linkage can be oriented in various directions including laterally and longitudinally.

3. The full energy return shoe sole of claim 2 wherein said combination linkage is a p-diamond linkage comprising

four diamond links hingeably interconnected to form a diamond shape with a top vertex, a bottom vertex, a front vertex and a rear vertex,

a top length link hingeably connected to said top vertex,

a bottom length link hingeably connected to said bottom vertex,

a mid length link hingeably connected at its front end to said rear vertex,

two end links hingeably connected to each other at the rear end of said

center length link, and

a mid-link front vertex guide rigidly extending along and from said mid length link to make a key constraint on said front vertex to move along the continuation line extending along the length of said mid length link.

4. The full energy return shoe sole of claim 2 wherein said combination linkage is a p-linkage comprising four p-links which form a parallelogram.

5. The full energy return shoe sole of claim 2 wherein said combination linkage is a 2p-linkage comprising seven 2p-links which form two parallelograms with a shared link.

6. The full energy return shoe sole of claim 1 wherein said top sole plate comprises a push-off means which allows said wearer to flex his metatarsal joint, push off his toe, and lift his

heel as he rocks forward onto his toe during toe-off, wherein said push-off means constrains the heel of said wearer to raise and lower directly above said top sole plate.

7. The full energy return shoe sole of claim 1 wherein the hinges which connect said links comprise necked hinges which are monolithic and which flex due to being necked down to a small width and a flexible material at said hinge.

8. The full energy return shoe sole of claim 1 wherein said springs and said full energy return linkage provide a substantially constant curve of the ground reaction force during stance.

9. The full energy return shoe sole of claim 1 wherein said bottom sole plate comprises a curved bottom.

10. The full energy return shoe sole of claim 1 wherein said space shoe further comprises elastic outer walls connecting said push-off frame and said top sole plate with said bottom sole plate.

11. The full energy return shoe sole of claim 1 wherein said bottom sole plate comprises a flex-rigger, flexibly attached to the sides of said bottom sole plate so that said flex-rigger can bend or rotate in the horizontal plane but not in the transverse-vertical plane, wherein said flex-rigger is biased to stick approximately straight out to the sides, wherein said flex-rigger is dimensioned and constructed to resist sideways roll over of said space shoe which could cause said wearer to sprain his ankle, wherein said flex-rigger can optionally be compressed inward along its length.

12. The full energy return shoe sole of claim 1 wherein said space shoe further comprises a front/back brace leg further comprising

a harness for coupling to a wearer's pelvis,

a front hip pivot,

a back hip pivot,

a front thigh link pivotly attached to the front of said harness with said front hip pivot,

a back thigh link pivotly attached to the front of said harness with said back hip pivot,

a front tibia link pivotly attached to the front of said brace foot,

a back tibia link pivotly attached to the back of said brace foot,

a front knee pivot connecting said front thigh link and said front tibia link,

a back knee pivot connecting said back thigh link and said back tibia link,

one or more hyper-extending knee pivot locks at the locations of said front and back knee pivots to prevent pivot hyper-extension,

an optional back hydraulic knee lock pivotly attached to said back thigh link and said back tibia link,

an optional front hydraulic knee lock pivotly attached to said front thigh link and said front tibia link,

a front ankle pivot for the connection of said front tibia link to said upper frame,

a back ankle pivot for the connection of said back tibia link to said upper frame,

a knee cross link connecting said front knee pivot with said back knee pivot, wherein said

front and back hip pivots are located approximately above the center of each leg, wherein the front and back locations of said brace leg elements prevents interference with said runner's legs.

13. The full energy return shoe sole of claim 12 wherein said harness comprises a front/back pack extension further comprising

a front pack-frame pivot at the front of said harness,

a back pack-frame pivot at the back of said harness,

a front pack frame attached to the front of said harness via said front pack-frame pivot,

a back pack frame attached to the back of said harness via said back pack-frame pivot,

pack straps,

a front pack secured to said front pack frame by said pack straps, and
back pack secured to said back pack frame by said pack straps, wherein said brace legs continuously support said front and back packs as said wearer walks or runs.

14. The full energy return shoe sole of claim 1 wherein said full energy return shoe sole provides energy return for a prosthetic leg, wherein said full energy return shoe sole further comprises a pylon attached to said upper frame, wherein said pylon attaches to the stump of an amputee's leg.

15. The full energy return shoe sole of claim 1 which further comprises a bow shoe for use by a runner, wherein said spring system comprises

a bow spring located above said upper frame and hingeably connected to said top sole plate,

a leg attachment means for attaching said bow spring to the leg of said runner,

a suspension system connecting the top of said bow spring to said lower sole plate, wherein the force of both the runner's toe and heel cause said bow spring to be loaded throughout foot-strike, wherein heel impact energy is not returned prematurely at the beginning of toe push-off, but rather is returned optimally during toe-off during the latter part of push-off.

16. The full energy return shoe sole of claim 15 wherein said suspension system comprises one or more ankle-pivot supports rigidly attached to said ground plate and extending around and above the level of the foot of said runner,

one or more ankle-pivot housings rigidly attached to said ankle-pivot support and housing an ankle pivot,

one or more cords attached to said shoe plate and passing around the foot of said runner and through said ankle-pivot housings, and

a cord guide to constrain said cords to the location of said ankle-pivot.

17. The full energy return shoe sole of claim 16 wherein said suspension system further comprises a shin-level bow spring assembly comprising

a bow spring pivotly attached to said ankle-pivot housing,

a bow guide pivotly attached to said ankle-pivot housing and to the top of said bow spring, wherein said bow guide changes length telescopically,

a shin slider slidingly attached to the top of said bow guide, and

a shin strap for attaching said shin slider to the shin of said runner, wherein said cords extend to connect to the top of said bow spring, wherein the impact force of said runner's foot on said shoe plate loads said bow spring via said cords.

18. The full energy return shoe sole of claim 1 wherein said bottom sole plate comprises a back-heel and a padded leg brace, wherein said back heel is a rigid, upwardly curving extension of said lower frame, wherein the deceleration of the runner's center of mass at heel strike is reduced by decreasing the effective angle of the line of force between the runner's center of mass and the initial point of contacts of said back-heel with the ground, wherein said padded leg brace impinges the leg of said runner above the ankle to prevent hyper plantar flexion at heel strike.

19. The full energy return shoe sole of claim 2 wherein said combination linkage is a arbitrary length 4-link linkage comprising four arbitrary length links hingeably interconnected.

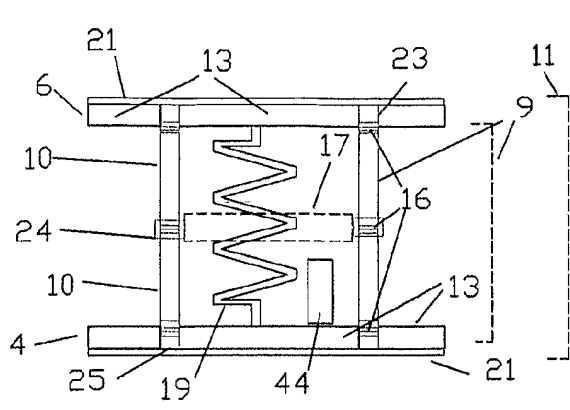

Figure 1c

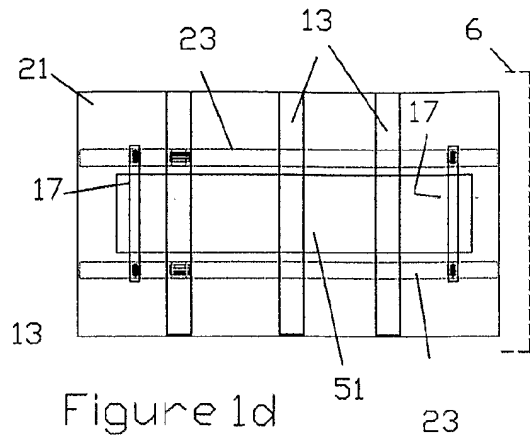

Figure 1d

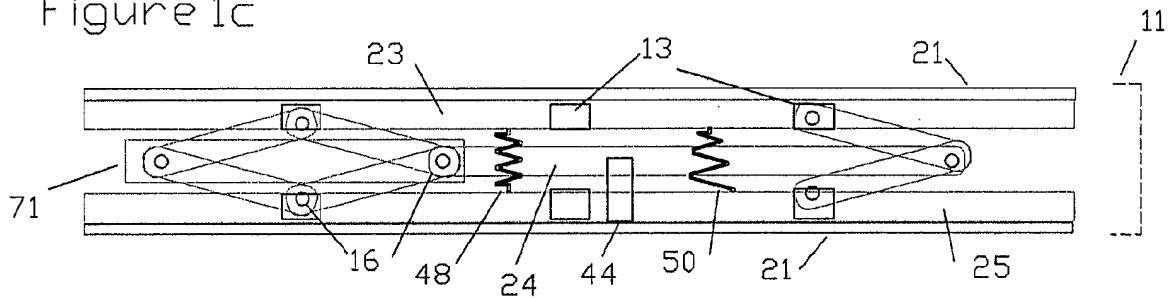

Figure 1b

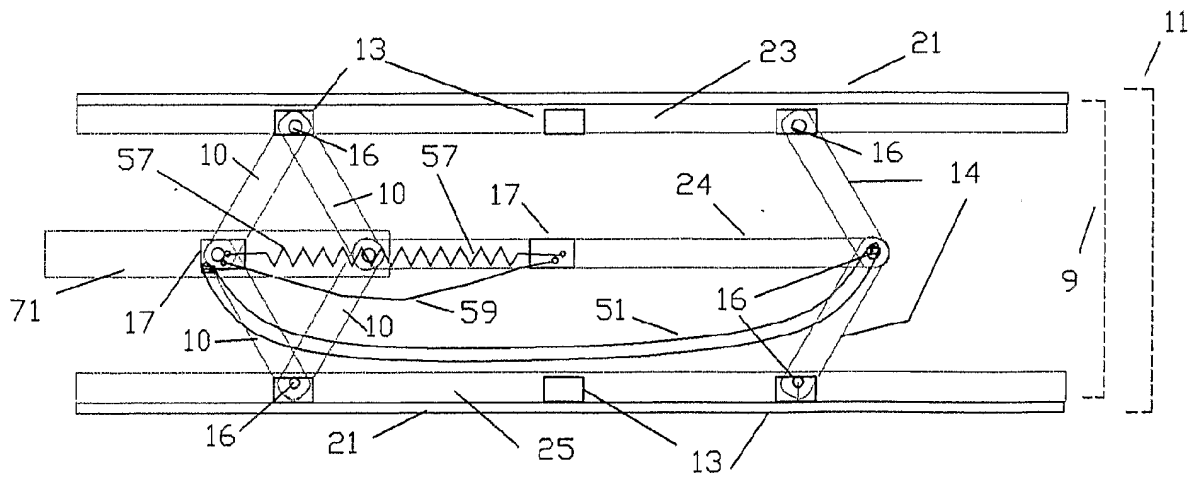

Figure 1a

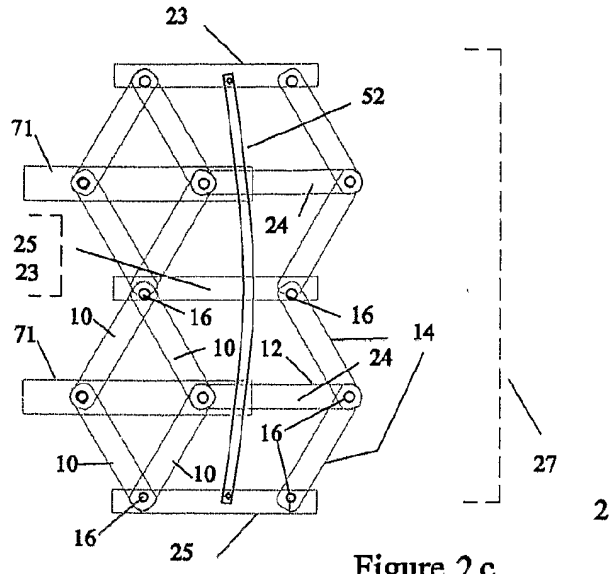

Figure 2 c

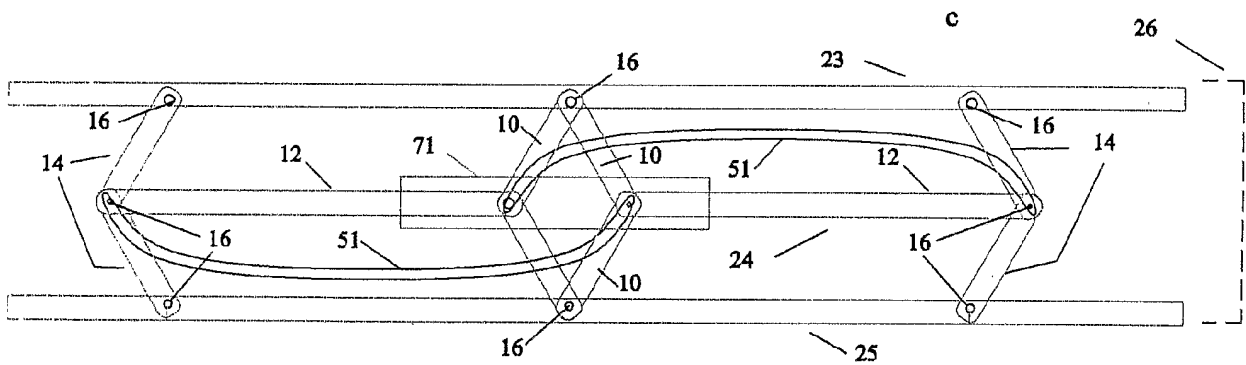

Figure 2 b

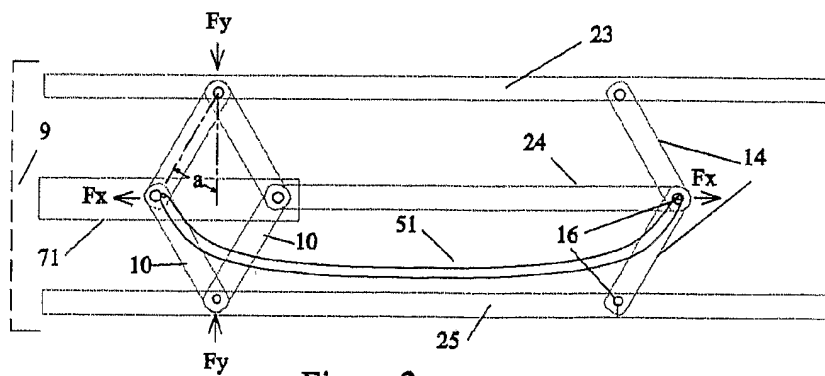

Figure 2 a

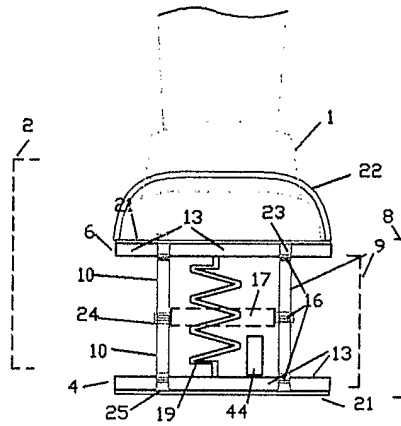

Figure 3 d

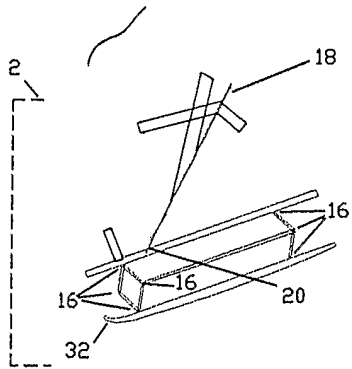

Figure 3 c

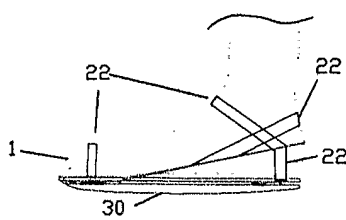

Figure 3 b

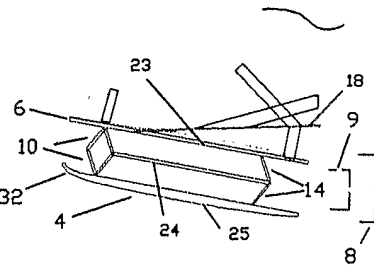

Figure 3 a

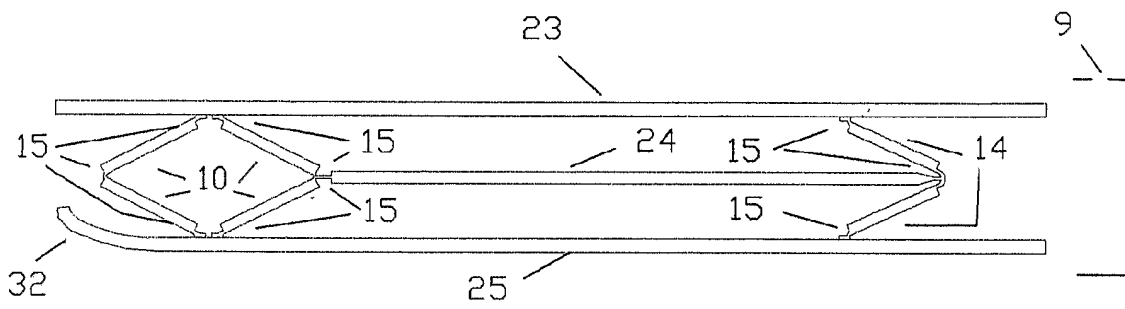

Figure 4b

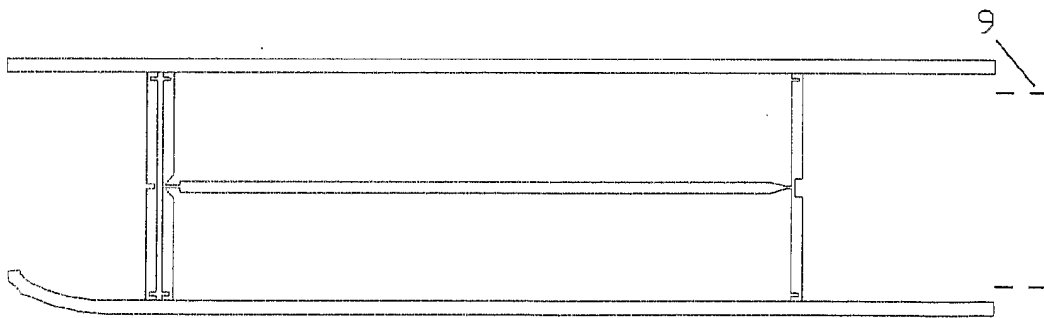

Figure 4a

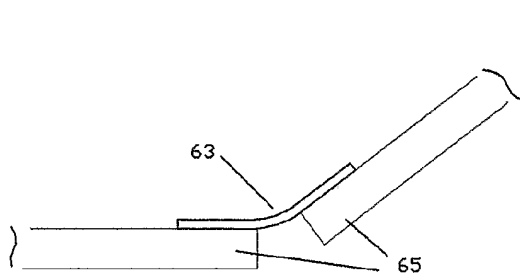

Figure 5 c

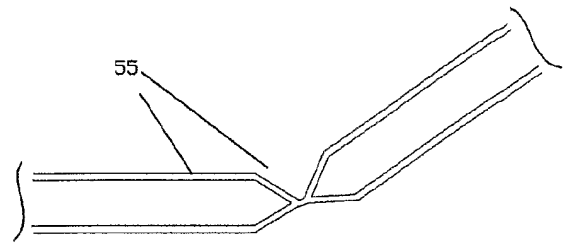

Figure 5 d

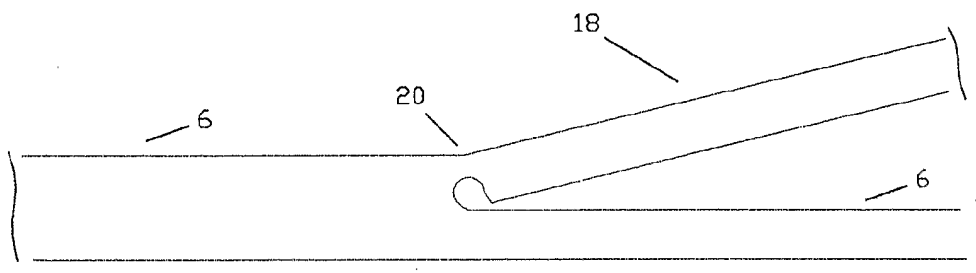

Figure 5 b

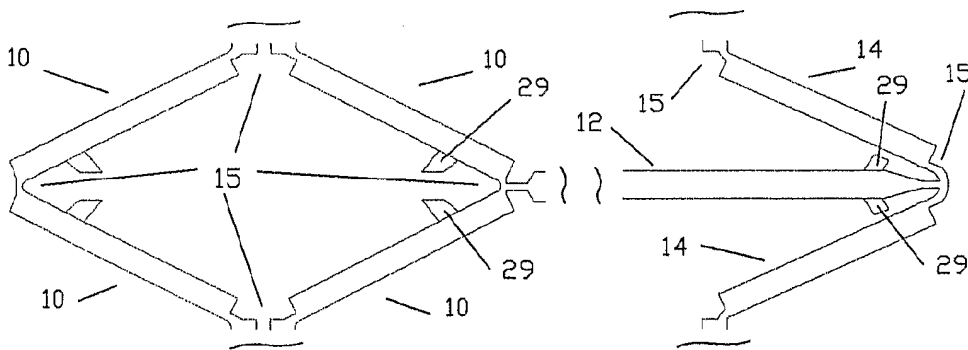

Figure 5 a

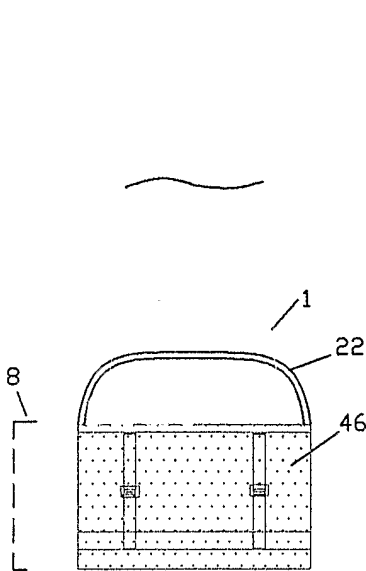

Figure 6 c

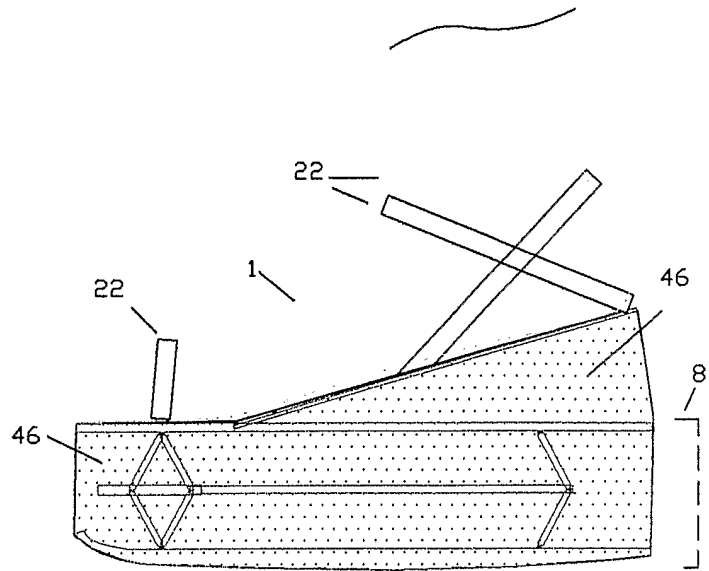

Figure 6 d

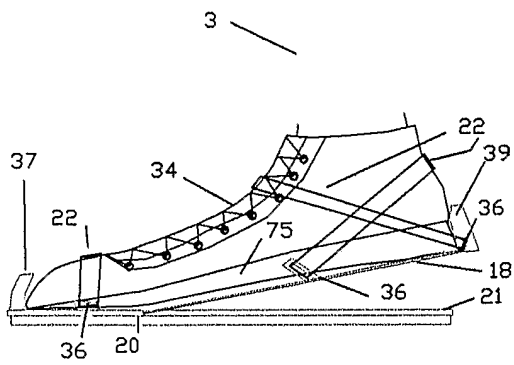

Figure 6 a

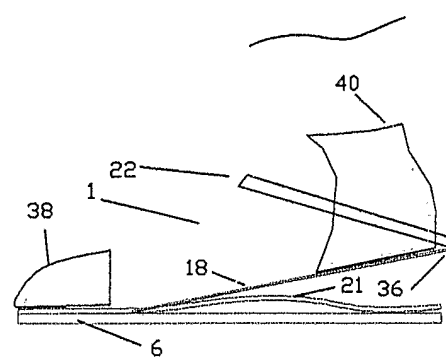

Figure 6 b

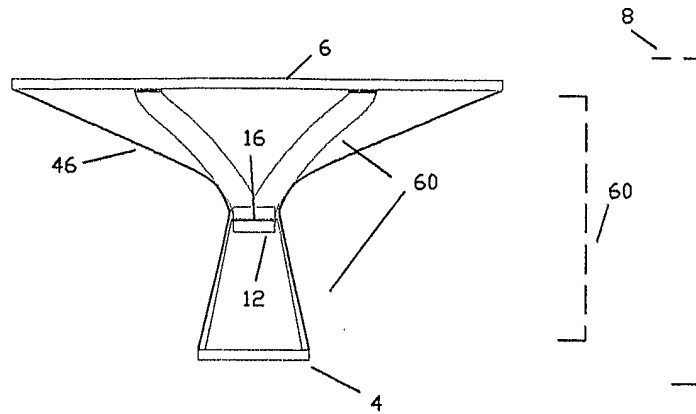

Figure 7 c

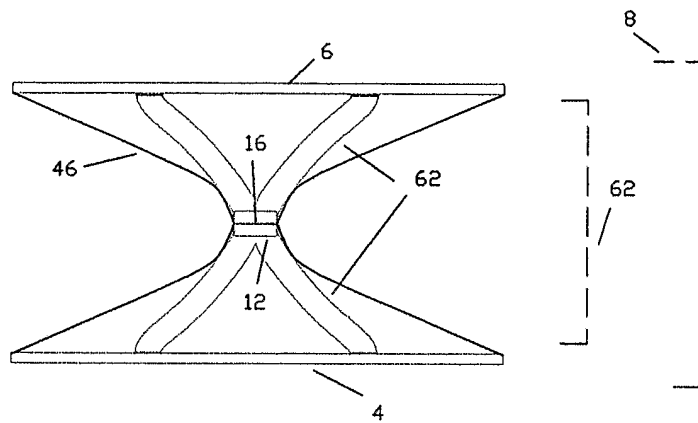

Figure 7 b

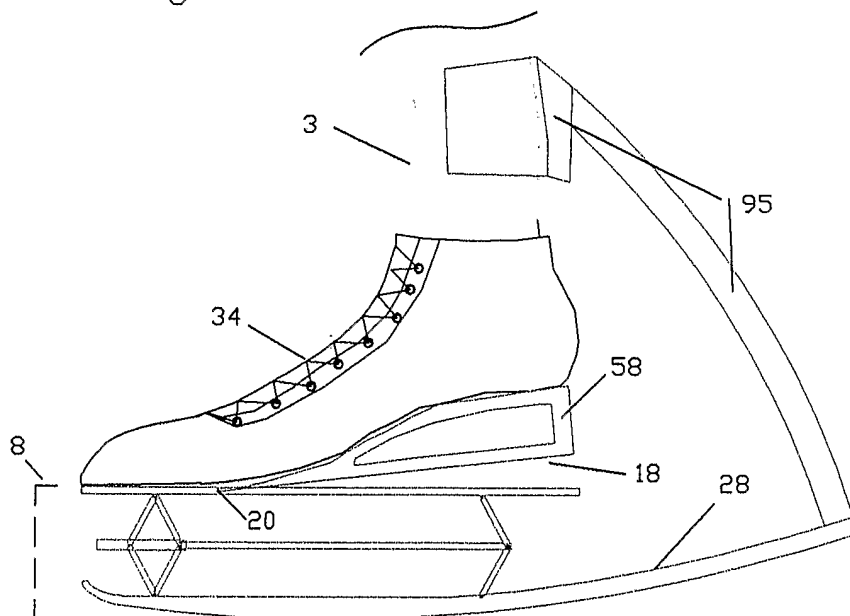

Figure 7 a

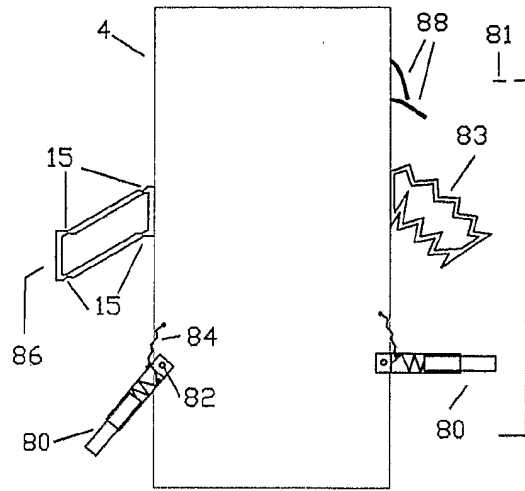

Figure 8 d

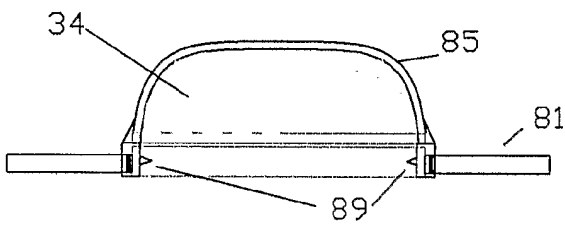

Figure 8 b

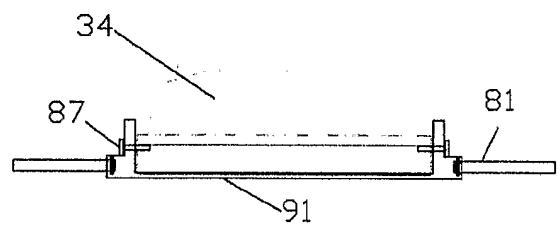

Figure 8 c

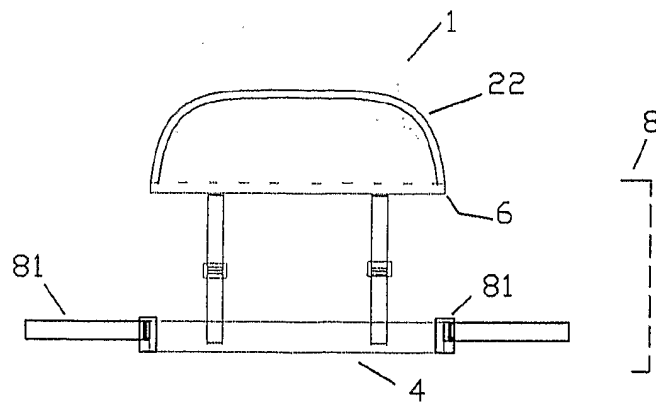

Figure 8 a

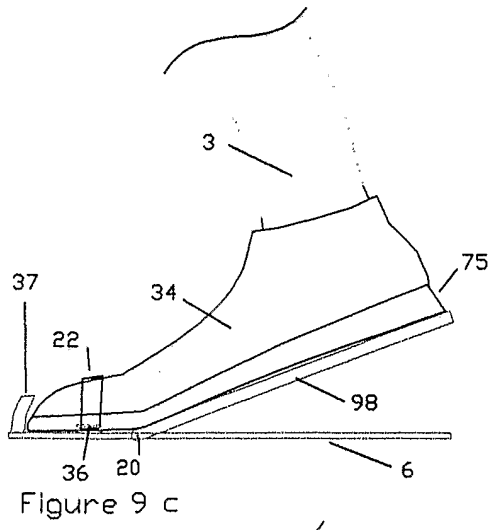

Figure 9 c

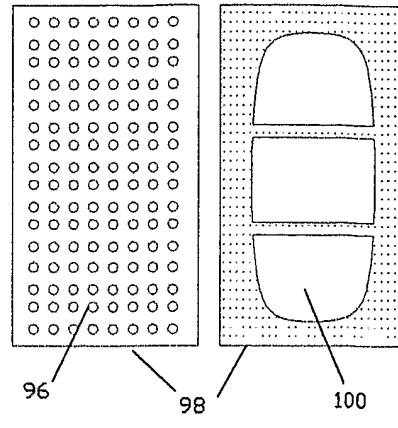

Figure 9 d

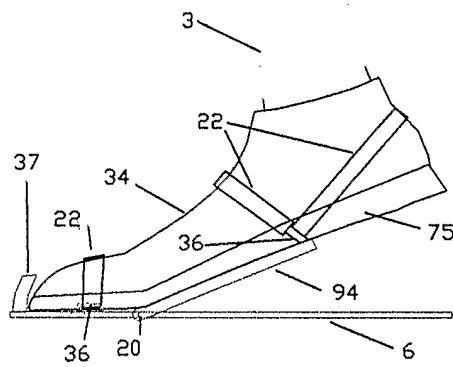

Figure 9 b

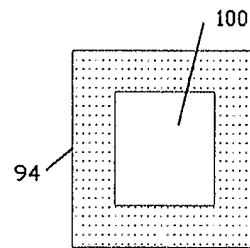

Figure 9 e

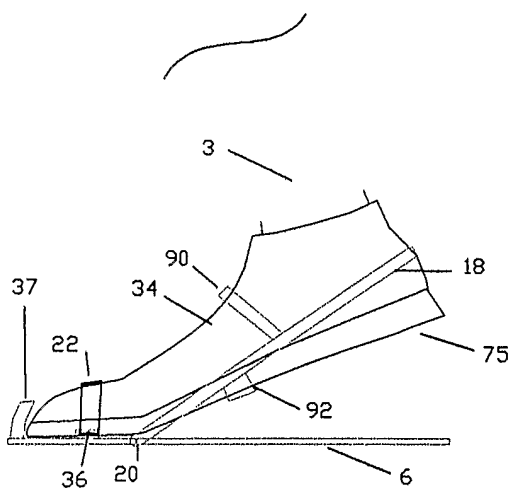

Figure 9 a

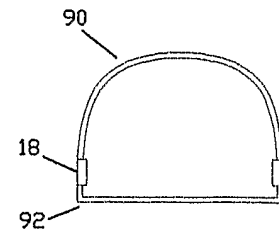
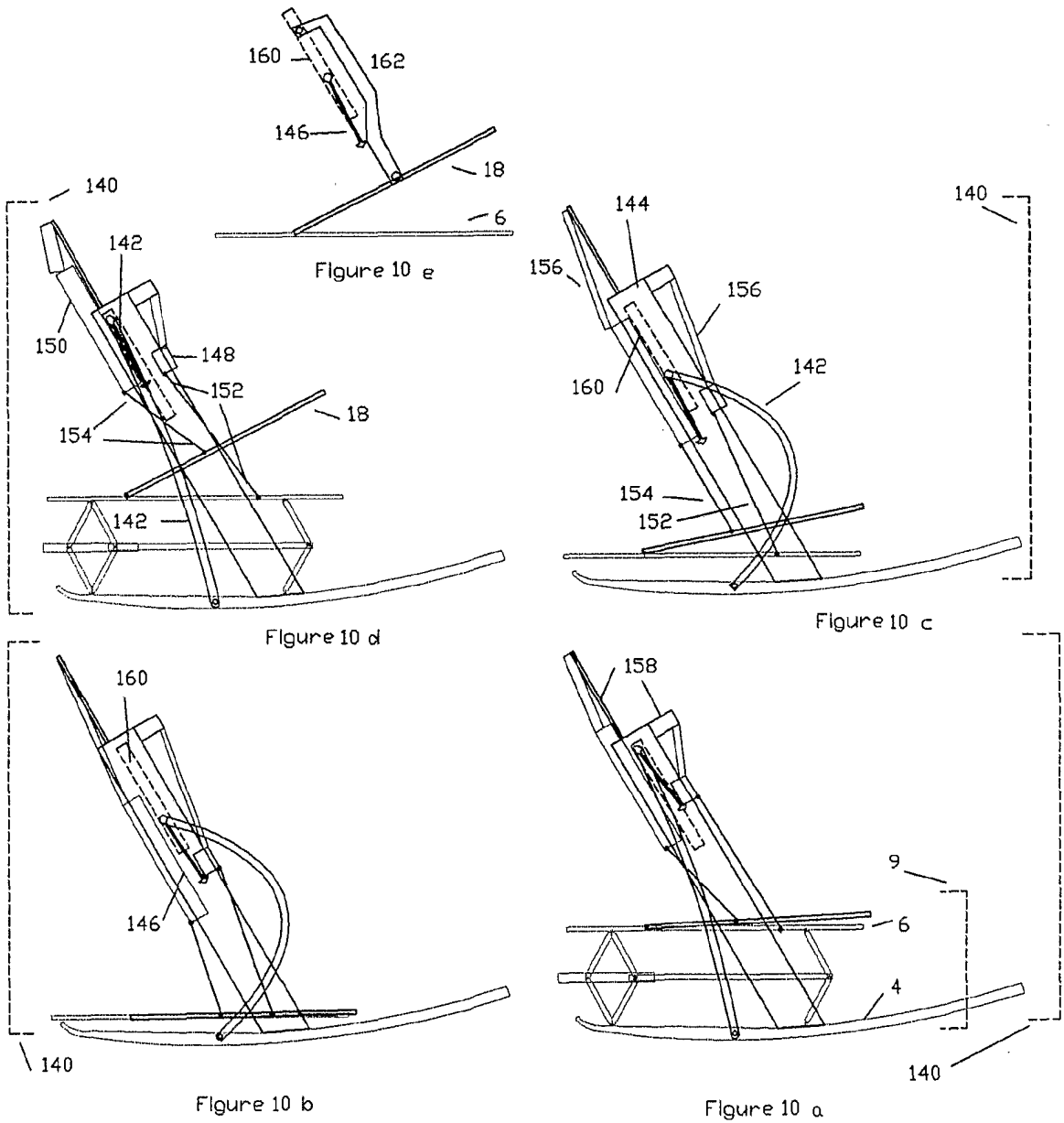
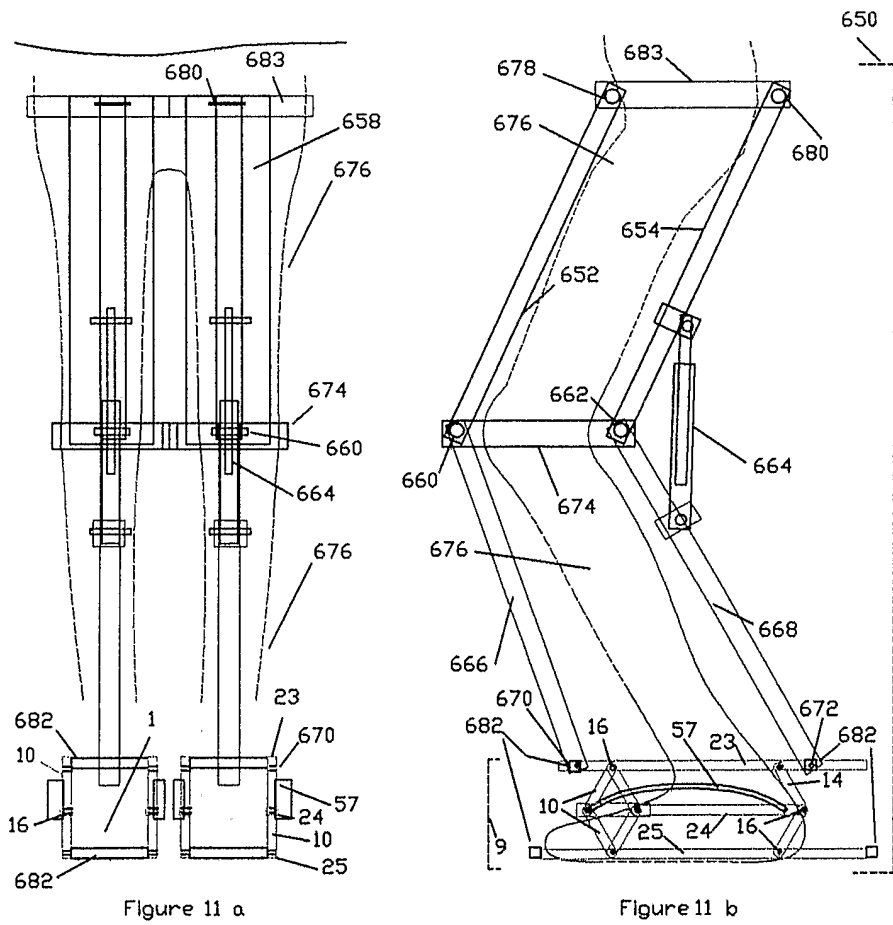
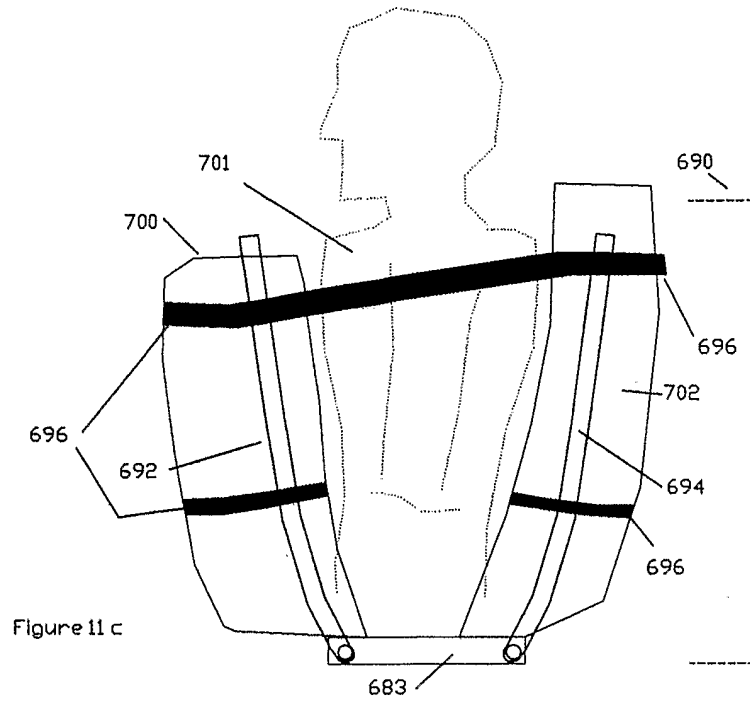
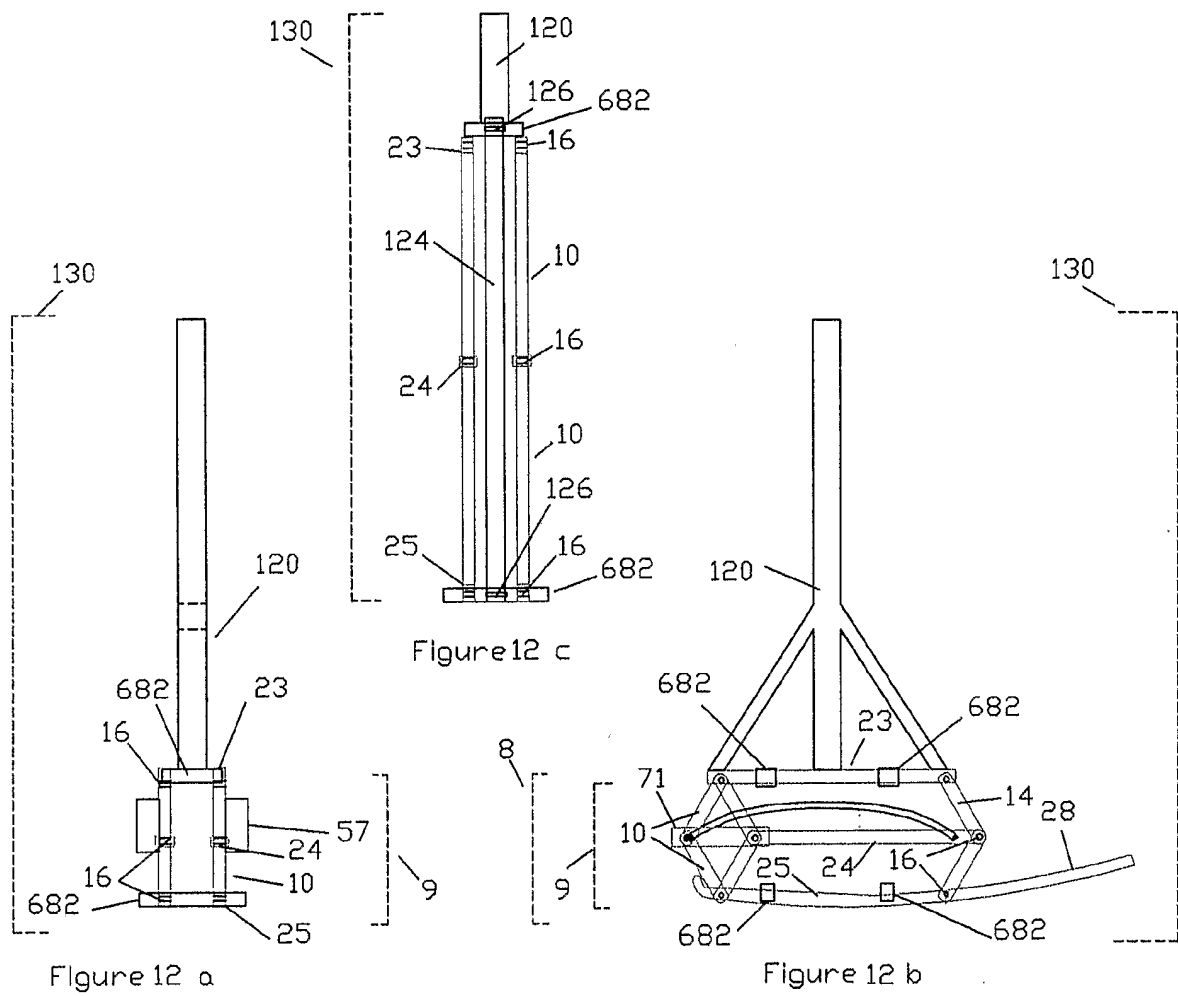
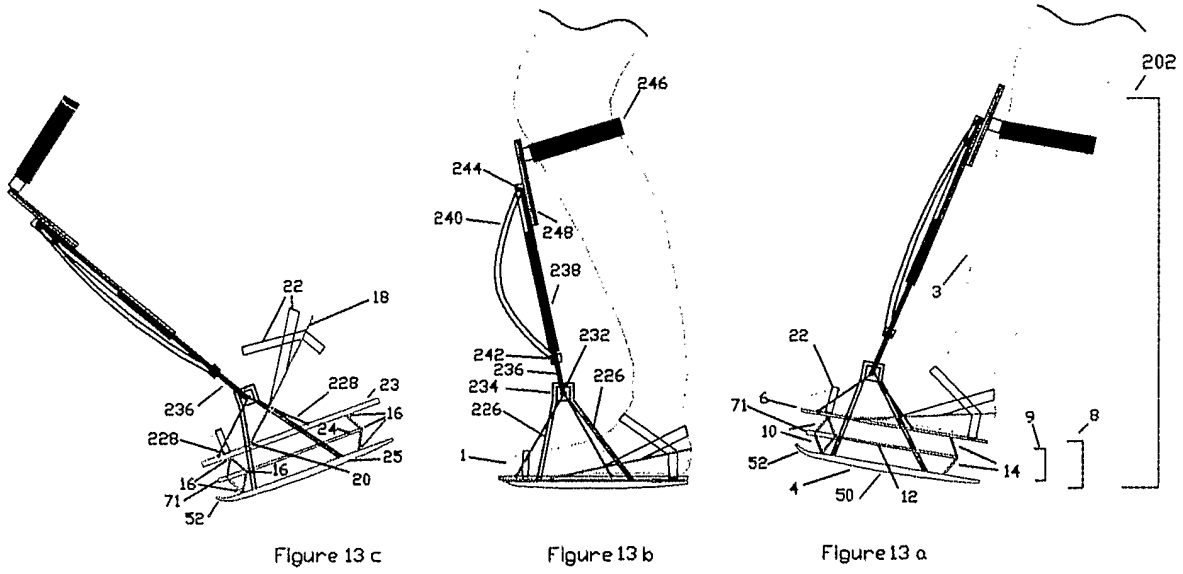

Figure 9 f









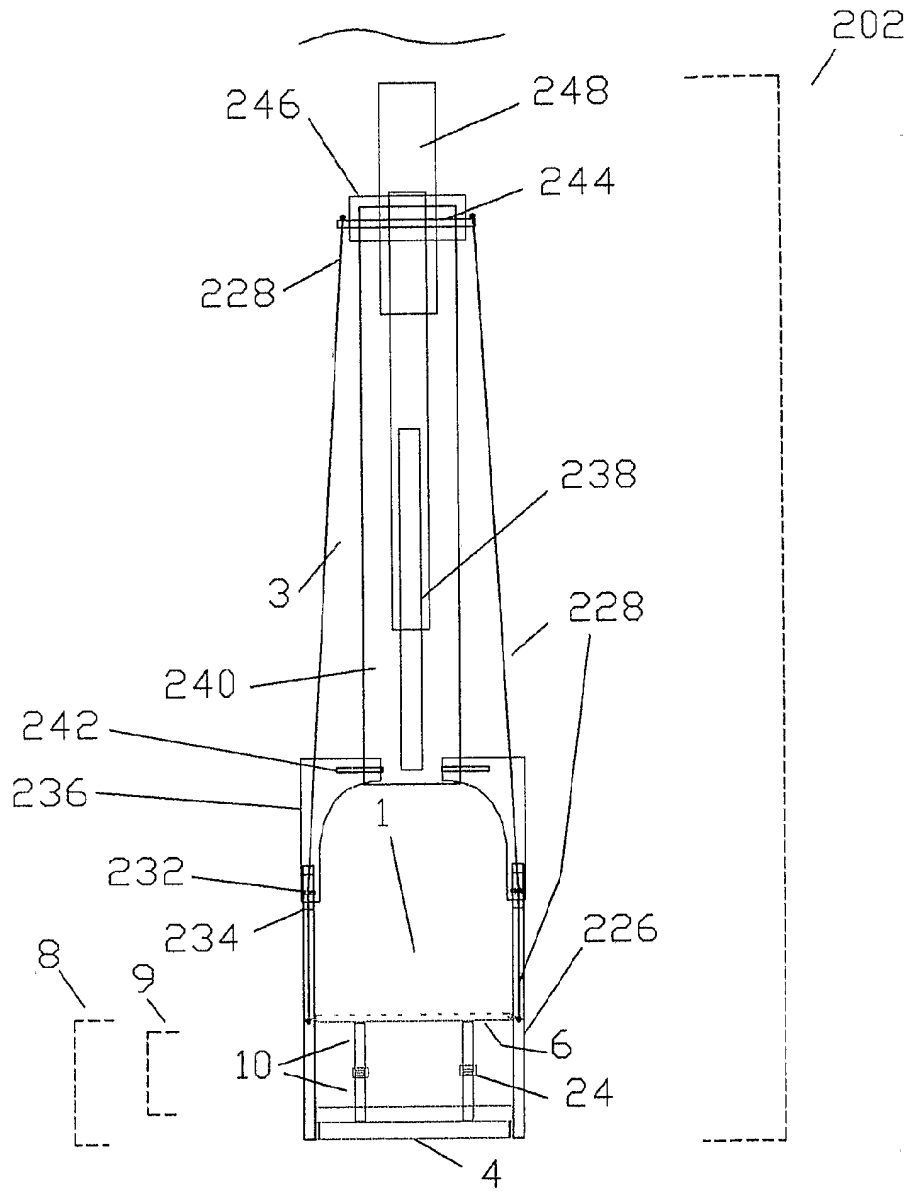

Figure 14

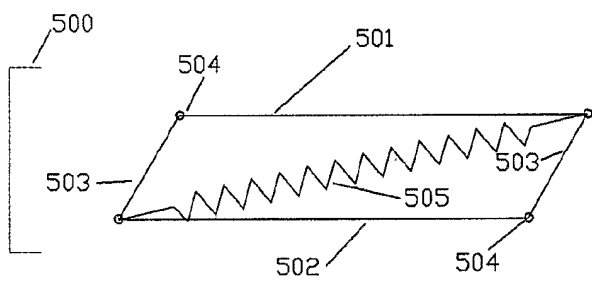

Figure 15 b

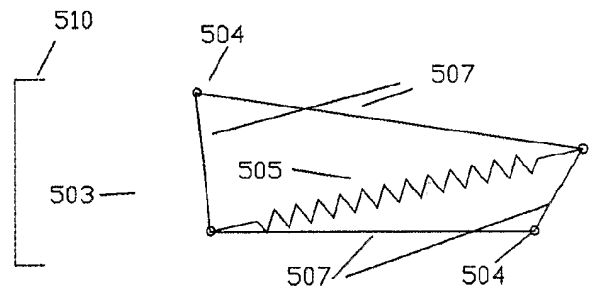

Figure 15 c

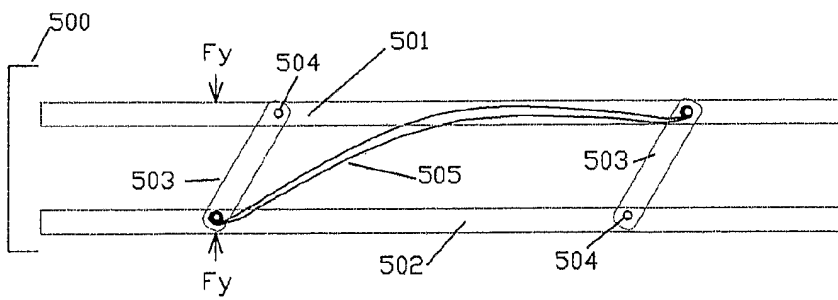

Figure 15 a

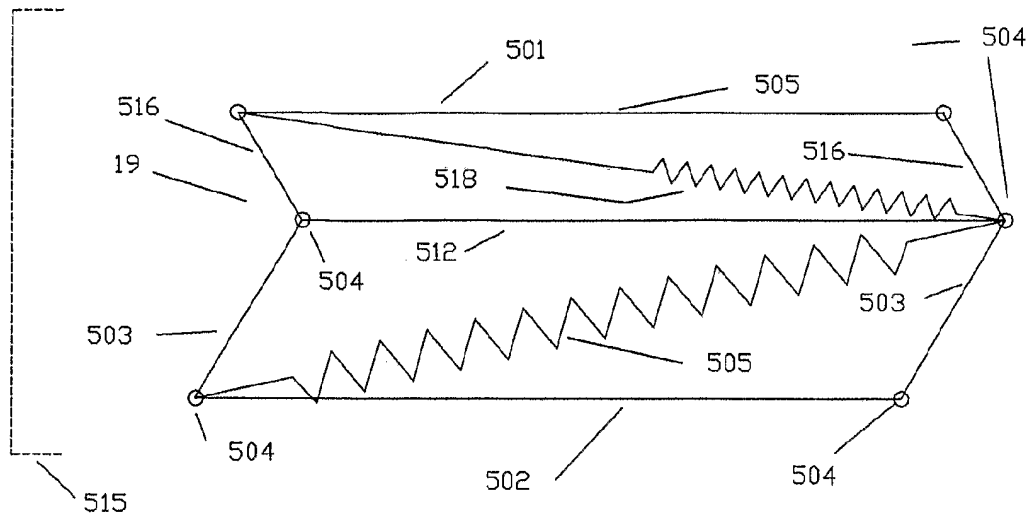

Figure 16 b

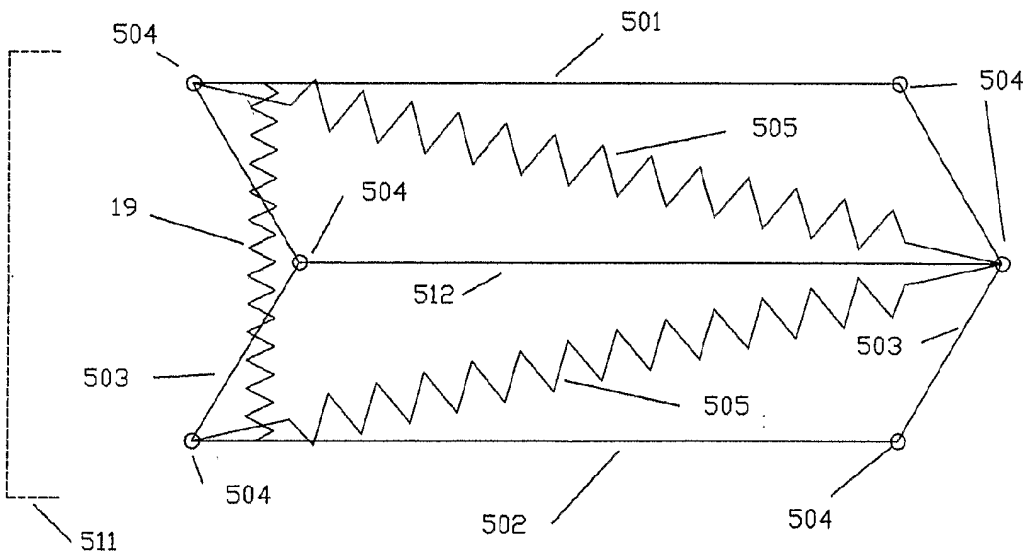

Figure 16 a

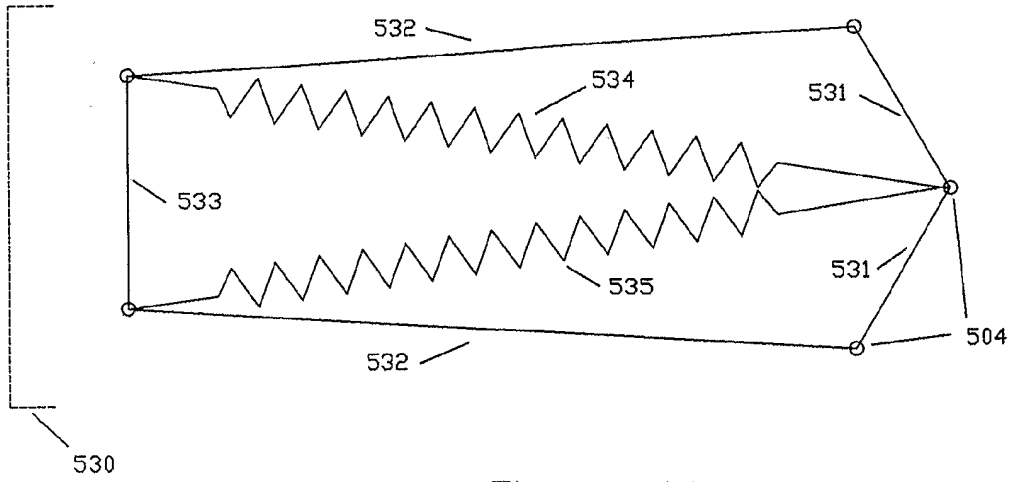

Figure 17 b

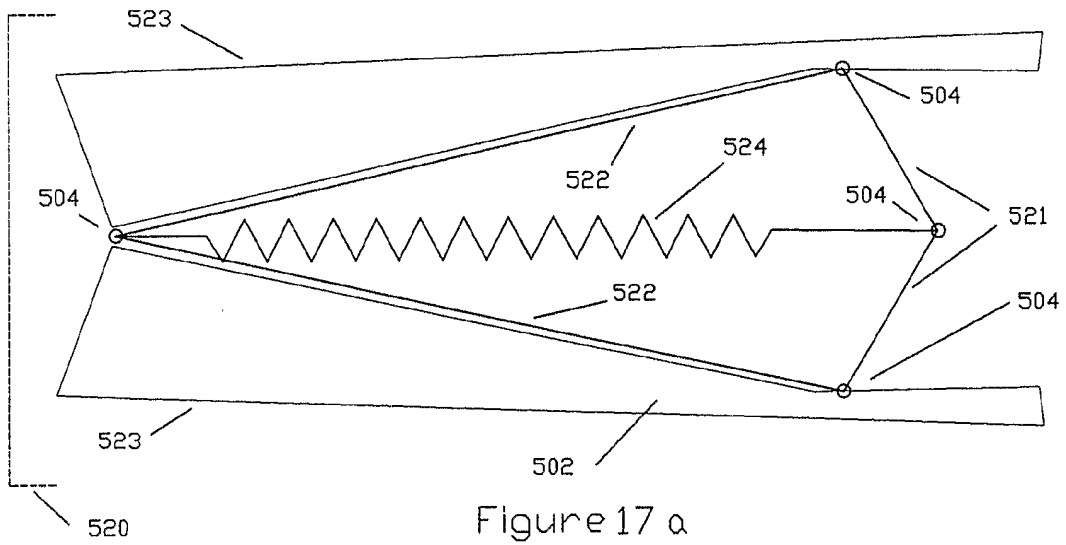

Figure 17 a

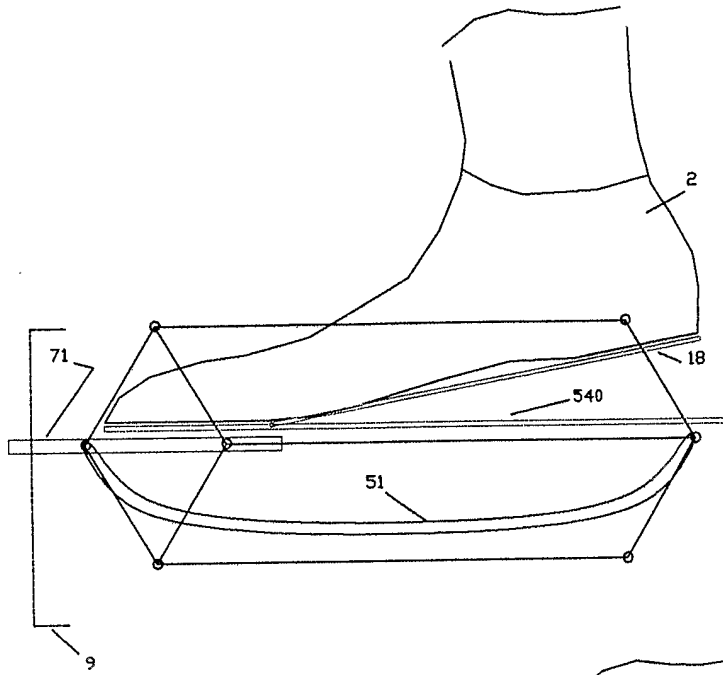

Figure 18 b

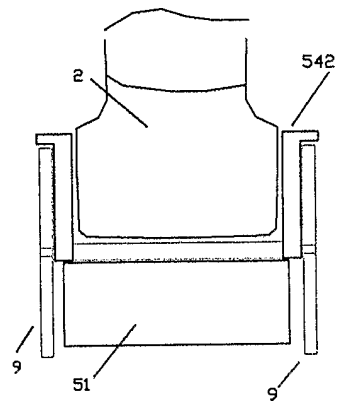

Figure 18 c

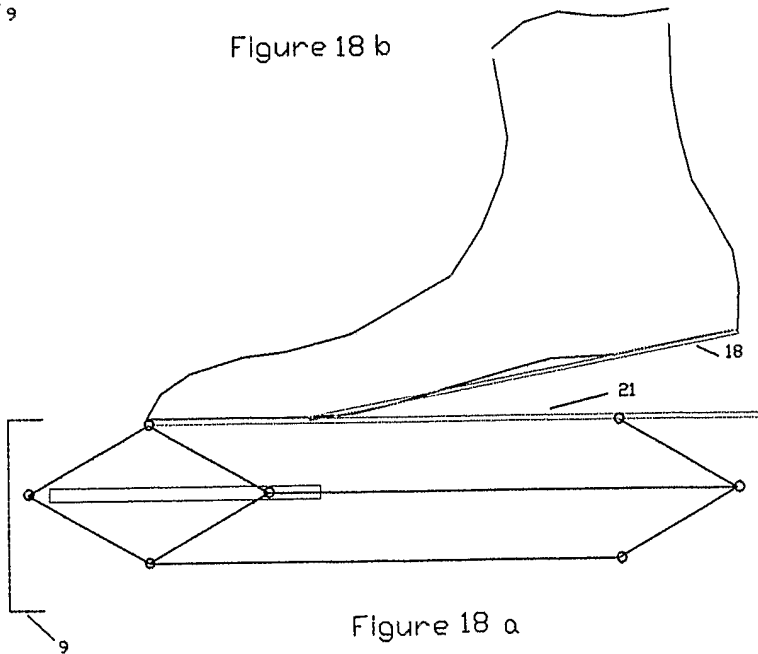

Figure 18 a

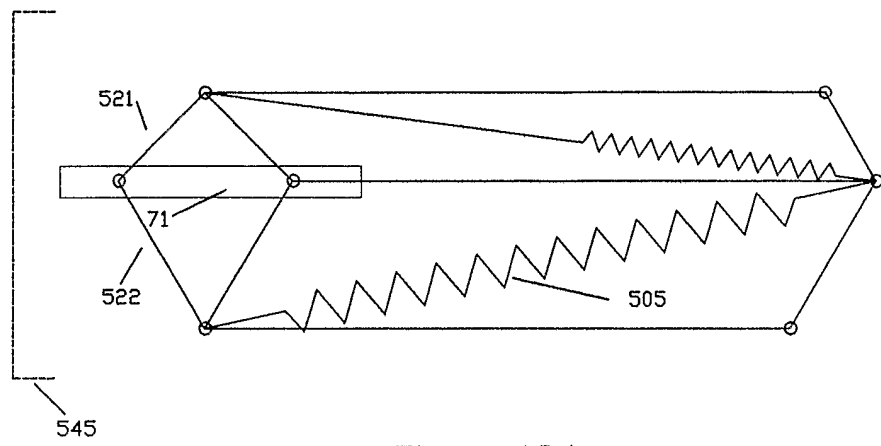

Figure 19 b

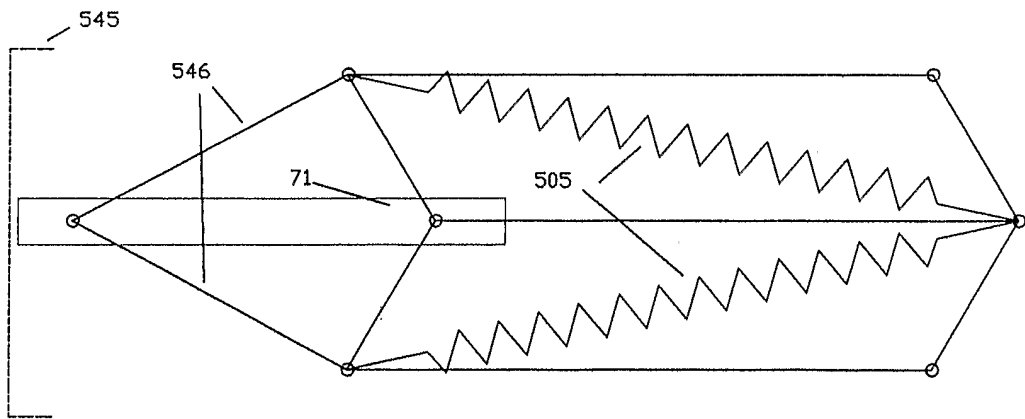

Figure 19 a