

(19)



(11)

EP 1 993 078 A2

(12)

EUROPEAN PATENT APPLICATION

(43) Date of publication:

19.11.2008 Bulletin 2008/47

(51) Int Cl.:

G07F 7/00 (2006.01)

(21) Application number: **08156050.0**

(22) Date of filing: **12.05.2008**

(84) Designated Contracting States:

AT BE BG CH CY CZ DE DK EE ES FI FR GB GR HR HU IE IS IT LI LT LU LV MC MT NL NO PL PT RO SE SI SK TR

Designated Extension States:

AL BA MK RS

(30) Priority: **16.05.2007 JP 2007130300**

(71) Applicant: **Sanden Corporation**

**Iseaki-shi,
Gunma 372-8502 (JP)**

(72) Inventors:

- **Kurihara, Toshihiko**
Iseaki-shi, Gunma 372-8502 (JP)

• **Tsunoda, Masaru**

Iseaki-shi, Gunma 372-8502 (JP)

• **Onda, Takeshi**

Iseaki-shi, Gunma 372-8502 (JP)

• **Yanagisawa, Yuuki**

**Iseaki-shi
Gunma 372-8502 (JP)**

• **Watanabe, Yoshitaka**

Iseaki-shi, Gunma 372-8502 (JP)

(74) Representative: **Haley, Stephen**

Gill Jennings & Every LLP

Broadgate House

7 Eldon Street

London EC2M 7LH (GB)

(54) **Commodity carrying out device**

(57) The present invention provides a commodity carrying out device that can reliably carry out a vertically-long shaped commodity in an upright state from a commodity storage column to a bucket. More specifically, since a commodity positioned at the front end side of a commodity storage column is tilted forward to be moved into a bucket, when moving a vertically-long shaped commodity in an upright state into a bucket, it is possible to move the commodity without the commodity toppling backwards. Thus, the commodity can be reliably moved into the bucket.

Fig. 1

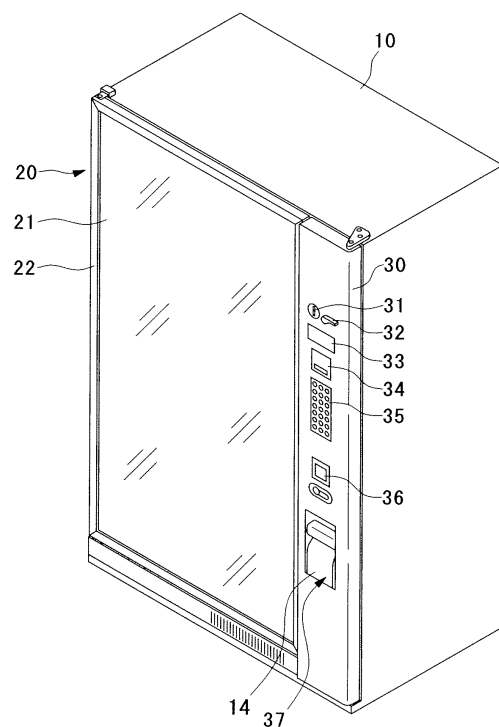

EP 1 993 078 A2

Description

[0001] The present invention relates to a commodity carrying out device that is capable of carrying out a commodity that is stored in a commodity storage column to a predetermined commodity carrying out position.

[0002] Conventionally, as a commodity carrying out device of this kind, a device is known that includes a plurality of commodity storage columns aligned in a vertical direction and a width direction with respect to each other in which commodities can be stored side by side in a front-to-rear direction, a bucket that receives a commodity stored in a commodity storage column that is selected, and a bucket moving mechanism that moves the bucket to a front side of an arbitrary commodity storage column and moves the bucket that receives a commodity to a predetermined commodity carrying out position.

[0003] However, in the conventional commodity carrying out device, a commodity stored in a commodity storage column is caused to be received in a bucket using a mechanism that moves a commodity, such as a belt conveyor provided in the commodity storage column and the bucket. Consequently, in a case in which a commodity that has a vertically long shape is being stored in an upright state in the commodity storage column, when the commodity is moved from the commodity storage column to the bucket the posture of the commodity becomes unstable and there is a risk that the commodity will topple backwards and it will not be possible to reliably carry out the commodity to the bucket.

[0004] An object of the present invention is to provide a commodity carrying out device that can reliably move a vertically-long shaped commodity in an upright state from a commodity storage column towards a bucket.

[0005] To achieve the aforementioned object, the present invention comprises: a plurality of commodity storage columns aligned in a vertical direction and a width direction with respect to each other in which commodities can be stored side by side in a front-to-rear direction; a bucket that receives a commodity stored in a commodity storage column that is selected; a bucket moving mechanism that moves the bucket to a front surface side of an arbitrary commodity storage column and moves the bucket that receives a commodity to a predetermined commodity carrying out position; and a commodity reception mechanism that tilts a commodity positioned at the front end side of a commodity storage column to the bucket side to move the commodity into the bucket.

[0006] Thus, since a commodity stored in a commodity storage column is tilted and moved to the bucket side, when a vertically-long shaped commodity is to be moved in an upright state into a bucket it is possible to move the commodity into the bucket without the commodity toppling backwards. Accordingly, since a commodity can be moved into the bucket without the commodity toppling backwards, a vertically-long shaped commodity can be reliably received in an upright state in the bucket.

[0007] The above and other objects, features, and ad-

vantages of the present invention will be apparent from the following description and the appended drawings.

[0008] In the Drawings;

- 5 FIG. 1 is an overall perspective view of an automatic vending machine that illustrates a first embodiment of the present invention;
 FIG. 2 is an overall perspective view of the automatic vending machine that shows a state in which an external door and an operation door are open;
 10 FIG. 3 is a side surface cross-section of the automatic vending machine;
 FIG. 4 is a plan view of essential parts of a commodity storage column;
 15 FIG. 5 is a front view of a commodity storage column;
 FIG. 6 is a side surface cross-section of essential parts of a commodity storage column;
 FIG. 7 is an overall perspective view of a bucket unit;
 FIG. 8 is a plan view of the bucket unit;
 20 FIG. 9 is a front view of the bucket unit;
 FIG. 10 is a rear view of the bucket unit;
 FIG. 11 is a side view of the bucket unit;
 FIG. 12 is an operation explanatory view relating to an operation to carry out a commodity;
 25 FIG. 13 is an operation explanatory view relating to an operation to carry out a commodity;
 FIG. 14 is an operation explanatory view relating to an operation to carry out a commodity;
 FIG. 15 is an operation explanatory view relating to an operation to carry out a commodity;
 30 FIG. 16 is an operation explanatory view relating to an operation to carry out a commodity;
 FIG. 17 is an operation explanatory view relating to an operation to carry out a commodity;
 FIG. 18 is an operation explanatory view relating to an operation to carry out a commodity;
 35 FIG. 19 is an operation explanatory view relating to an operation to carry out a commodity;
 FIG. 20 is an operation explanatory view relating to an operation to carry out a commodity;
 40 FIG. 21 is an operation explanatory view relating to an operation to carry out a commodity;
 FIG. 22 is an operation explanatory view relating to an operation to carry out a commodity;
 45 FIG. 23 is a side surface cross-section of a bucket unit and a commodity storage column that illustrates a second embodiment of the present invention;
 FIG. 24 is an operation explanatory view relating to an operation to carry out a commodity;
 50 FIG. 25 is a side surface cross-section of a bucket unit and a commodity storage column that illustrates a third embodiment of the present invention;
 FIG. 26 is an operation explanatory view relating to an operation to carry out a commodity;
 55 FIG. 27 is a side surface cross-section of a bucket unit and a commodity storage column that illustrates a fourth embodiment of the present invention; and
 FIG. 28 is an operation explanatory view relating to

an operation to carry out a commodity.

Detailed description of the invention

[0009] FIG. 1 to FIG. 22 illustrate the first embodiment of the present invention.

[0010] An automatic vending machine that includes this commodity carrying out device comprises an automatic vending machine main unit 10 that has an opening at the front, an external door 20 provided in an openable and closable condition at one end side in the width direction of the opening of the automatic vending machine main unit 10, and an operation door 30 provided in an openable and closable condition at the other end side in the width direction of the opening of the automatic vending machine main unit 10.

[0011] The automatic vending machine main unit 10 is provided with a commodity storage chamber 12 for storing commodities A for sale and an equipment storage chamber 13 for storing equipment relating to selling operations. This is achieved by partitioning the inside of the automatic vending machine main unit 10 in the width direction with a heat insulating partition wall 11. The interior surface of the commodity storage chamber 12 is covered with a heat insulating material. At the lower part of the equipment storage chamber 13 is provided a commodity outlet portion 14 to which a commodity A to be sold is carried. An opening 15 that connects the commodity outlet portion 14 and the commodity storage chamber 12 is provided in the partition wall 11.

[0012] The external door 20 is rotatably supported at one end side in the width direction of the automatic vending machine main unit 10 and is arranged to open and close the front of the commodity storage chamber 12. The external door 20 comprises a transparent plate 21 comprising glass or a synthetic resin or the like and a frame member 22 provided around the perimeter of the transparent plate 21. The interior of the commodity storage chamber 12 can be visually recognized from outside the external door 20.

[0013] The operation door 30 is rotatably supported at the other end side in the width direction of the automatic vending machine main unit 10 and is arranged to open and close the front of the equipment storage chamber 13. At the front of the operation door 30 are provided a coin insertion slot 31, a coin return lever 32, a money amount indicator 33, a banknote insertion slot 34, a commodity selection portion 35, a coin return port 36, and a commodity outlet port 37.

[0014] In the commodity storage chamber 12 are provided a plurality of commodity storage columns 50 that are disposed in alignment in the width direction with a plurality of vertically spaced shelves 40, respectively, a bucket unit 60 as a commodity carrying out device for carrying a commodity A stored in a commodity storage column 50 to the commodity outlet portion 14, and a unit moving device 70. The commodity storage chamber 12 is also configured so as to be cooled or heated by a cooler

and an electric heater that are not shown. At the lower part of the commodity storage chamber 12 is provided an equipment chamber for housing unshown refrigerating devices such as a compressor and a radiator.

[0015] The space dimensions of each of the vertically aligned shelves 40 are slightly greater than the height dimensions of a commodity A to be stored. This prevents erroneous storage of a commodity A that has large height dimensions that are different to the height dimensions of a commodity A that is intended to be stored. Each shelf 40 is formed so that the dimensions thereof in the front-to-rear direction are smaller than the dimensions in the front-to-rear direction of the commodity storage column 50. Further, to secure an operating space for receiving a commodity A into the bucket unit 60 from the commodity storage column 50, the front end of each shelf 40 is positioned further to the rear side than the front end of the commodity storage column 50.

[0016] Each commodity storage column 50 is provided with a commodity passage 50a extending in the front-to-rear direction that is formed by a base plate 51 and a side plate 52. Vertically long commodities A such as canned beverages, bottled beverages, or PET bottles can be stored in the commodity passage 50a in a condition in which they are aligned in the front-to-rear direction. At the front end side of the base plate 51, a commodity locking portion 51a that is formed to extend vertically is provided for restricting movement of a commodity A in the frontward direction. Further, on the front end side of the base plate 51 is provided a notch portion 51b that enables movement of a fork member, described later, of the bucket unit 60 in the vertical direction.

[0017] Each commodity storage column 50 comprises an ejecting plate 53 which is provided in a moveable condition in the front-to-rear direction with respect to the commodity passage 50a and which is urged forward by an unshown urging member such as a power spring. By storing a commodity A at the front side of the ejecting plate 53, the commodity A receives an urging force that urges the commodity A forward. Further, the ejecting plate 53 is provided with a notch portion 53a that enables movement of a fork member, described later, of the bucket unit 60 in the vertical direction when the ejecting plate 53 is positioned at the front end side of the commodity passage 50a.

[0018] In each commodity storage column 50, a gate plate 54 that opens and closes the front end side of the commodity passage 50a is connected in a vertically rotatable condition to the front end side of the side plate 52. The gate plate 54 is arranged so as to block off the commodity passage 50a in a posture in which it extends diagonally upward from the side plate 52. The gate plate 54 is urged in a direction that blocks off the commodity passage 50a by an urging member such as a coiled spring. Further, the gate plate 54 is arranged to open the commodity passage 50a by rotating upward against the urging force of the urging member through contact of a gate release portion, described later, provided on the

bucket unit 60 side against the bottom surface of the gate plate 54. A guide portion 52a for guiding the gate release portion in the front-to-rear direction is also provided on the commodity passage 50a side of the side plate 52 on which the gate plate 54 is supported.

[0019] The bucket unit 60 comprises a unit base 61 that is connected with a unit moving device 70, a bucket base 62 that is moveable in the front-to-rear direction with respect to the unit base 61, a rotating member 63 that is rotatably supported by the bucket base 62 with the vertical direction as the central axis, a bucket 64 that is supported by the rotating member 63 and is provided to support a side surface of a commodity A that is carried out, a fork member 65 that is rotatably supported in the vertical direction by the lower end of the bucket 64 and which supports the bottom surface of a commodity A that is carried out, a rotation restricting member 66 for restricting rotation of the fork member 65, a commodity detecting plate 67 for detecting the existence or non-existence of a commodity A within the bucket 64, and a restriction releasing member 68 for releasing the rotation restriction of the fork member 65 by the rotation restricting member 66.

[0020] The unit base 61 has an electric motor 61a as a motive power that moves the bucket base 62 in the front-to-rear direction and also rotates the bucket 64, a guide groove 61b for guiding the bucket base 62 in the front-to-rear direction, a protrusion 61c that imparts a force that rotates the rotating member 63 to the commodity outlet portion 14 side upon movement of the bucket base 62 to the front, a pair of width direction rails 61d for regulating movement of the fork member 65 in the width direction to guide the fork member 65 in the front-to-rear direction, and a commodity detecting sensor 61e such as a microswitch that is turned on/off by the commodity detecting plate 67.

[0021] The two ends on the left and right of the bottom surface side and the upper and lower sides of one end in the width direction of the bucket base 62 are formed so as to engage with the guide groove 61b that is provided in the unit base 61 so that the bucket base 62 is movable along the guide groove 61b. A groove 62a extending in the width direction is also provided on the bottom surface of the bucket base 62, and a link member 69 having one end connected to the electric motor 61a is arranged so that the other end side thereof engages with the groove 62a. More specifically, when the link member 69 is rotated by the electric motor 61a, the bucket base 62 is moved in the front-to-rear direction along the guide groove 61b by the movement of the other end side of the link member 69. An abutting portion 62b formed to have a curved surface shape is provided in the bucket base 62. The surface of the bucket 64 on the opposite side of the commodity receiving surface contacts against the abutting portion 62b. A gate release portion 62c that extends rearward from a position below the abutting portion 62b is also provided in the bucket base 62. By rearward movement of the bucket base 62, the gate release portion 62c press-

es the gate plate 54 upward to open the front end side of the commodity passage 50a.

[0022] The rotating member 63 is connected to the bucket 64 in a condition in which the bucket 64 is rotatable backwards and forwards. Further, an end in the width direction of the rotating member 63 is rotatably connected to the bucket base 62. The rotating member 63 is urged by an unshown urging member so that the commodity receiving surface of the bucket 64 faces rearward (towards the commodity storage column side). More specifically, the rotating member 63 moves in the front-to-rear direction together with the bucket base 62 in a state in which the commodity receiving surface of the bucket 64 faces rearward. Furthermore, when the bucket base 62 moves to the front end side of the unit base 61, the rotating member 63 is pushed by the protrusion 61c arranged in the unit base 61 so as to extend rearward. As a result, the orientation of the rotating member 63 changes by 90° to the commodity outlet portion 14 side.

[0023] The bucket 64 is formed in a semi-cylindrical, curved surface shape in which a concave side serves as a commodity receiving surface. In the bucket 64, the lower end side is rotatably connected to the rotating member 63, and a surface on a side opposite the commodity receiving surface is supported by the abutting portion 62b of the bucket base 62 so that the commodity receiving surface faces diagonally upward. The angle of inclination of the bucket 64 is arranged so as to be changed in accordance with the shape of the abutting portion 62b of the bucket base 62 and the shape of the bucket 64 against which the abutting portion 62b abuts. According to the present embodiment, when the bucket 64 rotates to the commodity outlet portion 14 side, the angle of inclination of the bucket 64 at the start of rotation is set to be less than when receiving a commodity A. Thereafter, when the bucket 64 faces completely to the commodity outlet portion 14 side, the angle of inclination is set to be larger than when receiving a commodity A. An opening for attaching the commodity detecting plate 67 is provided at the center in the width direction of the bucket 64, in a condition in which the opening extends in the vertical direction.

[0024] The base end side of the fork member 65 is connected to the lower end side of the bucket 64 in a condition in which the fork member 65 is rotatable in the vertical direction. The fork member 65 is provided with a plurality of commodity supporting portions 65a that are arranged with a space between each commodity supporting portion 65a. On the under surface of the fork member 65 are provided a pair of grooves 65b for moving the fork member 65 along the pair of width direction rails 61d provided in the unit base 61 that restrict movement in the width direction of the fork member 65. The upper surface of the fork member 65 is inclined in a normal state from the base end side towards the front end side. On the bottom surface on the base end side of the fork member 65 is provided a contact surface 65c that contacts with the top surface of the unit base 61. The angle

of the top surface of the fork member 65 can be changed depending on the shape of the top surface of the unit base 61. More specifically, the top surface of the unit base 61 against which the contact surface 65c contacts is formed to be low at the rear end side so that when the bucket base 62 is positioned at the rear end side, the angle of inclination of the top surface of the fork member 65 is small, and when the bucket base 62 is disposed at a position other than the rear end side, the angle of inclination of the top surface of the fork member 65 is greater than when the bucket base 62 is positioned at the rear end side.

[0025] The rotation restricting member 66 is arranged to be moveable in the vertical direction at a lower part of the surface on the opposite side to the commodity receiving surface of the bucket 64, and is urged toward the bottom side by an unshown urging member. The rotation restricting member 66 contacts against the end on the base end side of the fork member 65 in a state in which the rotation restricting member 66 is positioned on the lower side to thereby restrict downward rotation of the fork member 65. The rotation restricting member 66 is arranged so as to release the restriction on downward rotation of the fork member 65 by moving upward. The rotation restricting member 66 is arranged so as to be pressed upward by the restriction releasing member 68.

[0026] The commodity detecting plate 67 extends in the vertical direction over the commodity receiving surface side of the bucket 64, and the top end side thereof is rotatably supported by the bucket 64. Similarly to the bucket 64, the commodity detecting plate 67 is formed in a curved surface shape so that a center portion in the width direction of the commodity receiving surface curves inward vertically so that a commodity A that is received in the bucket 64 is moved to the center portion side. The lower end side of the commodity detecting plate 67 is urged in a direction away from the commodity receiving surface of the bucket 64 by an unshown urging member so as to rotate when a commodity A is received. A commodity detecting sensor 61e provided in the unit base 61 is arranged so as to be turned on/off by the top end of the commodity detecting plate 67 in a state in which the commodity receiving surface of the bucket 64 is facing the commodity outlet portion 14 side. According to the present embodiment, in a state in which the commodity receiving surface of the bucket 64 is facing the commodity outlet portion 14 side, when the bucket 64 contains a commodity A, the commodity detecting sensor 61e turns off, and when the bucket 64 does not contain a commodity A, the commodity detecting sensor 61e turns on. An abutting portion 67a against which the rotation restricting member 66 that moves upward contacts is provided in a projecting condition on the surface of the side opposite the commodity receiving surface of the commodity detecting plate 67. When the rotation restricting member 66 contacts against the abutting portion 67a in a state in which a commodity A is in the bucket 64, the lower end side of the commodity detecting plate 67 moves towards

the commodity A to push out the commodity A from the bucket 64.

[0027] The restriction releasing member 68 is provided in a condition in which it is linearly moveable in a diagonally upward direction on the commodity outlet portion 14 side of the unit base 61. The restriction releasing member 68 is arranged so as to push the rotation restricting member 66 upward when the restriction releasing member 68 is operated in a state in which the commodity receiving surface of the bucket 64 is facing the commodity outlet portion 14 side. The restriction releasing member 68 is arranged so as to be operated by contact with an operating portion 16 that is provided adjacent to the opening 15 that communicates with the commodity outlet portion 14 upon the operating portion 16 moving horizontally to the commodity outlet portion 14 side of the unit base 61. Further, the restriction releasing member 68 has an abutting portion 68a that extends to the bucket base 62 side. The restriction releasing member 68 is arranged so as to be lowered downward by contact of the bucket base 62 with the abutting portion 68a when the bucket base 62 moves rearward.

[0028] The unit moving device 70 is provided at the front side of the commodity storage chamber 12. The unit moving device 70 comprises a widthwise movement mechanism 71 for moving the bucket unit 60 in the width direction and a vertical movement mechanism 72 for moving the bucket unit 60 in the vertical direction. The widthwise movement mechanism 71 and the vertical movement mechanism 72 are respectively constituted by an unshown mechanism that converts rotational motion into linear motion, such as a belt and pulley, a chain and sprocket, or a feed screw mechanism. The widthwise movement mechanism 71 and the vertical movement mechanism 72 are respectively arranged to be driven by an electric motor so as to move the bucket unit 60 in the width direction and the vertical direction.

[0029] In the automatic vending machine configured as described above, when a user inserted a predetermined amount of money into the coin insertion slot 31 or the banknote insertion slot 34 and selects a predetermined commodity A at the commodity selection portion 35, first, the bucket unit 60 that is positioned at a predetermined standby position moves using the unit moving device 70 to the front end side of a commodity storage column 50 in which the selected commodity A is stored. Next, as shown in FIG. 12, the electric motor 61a is driven to lower the commodity supporting portion 65a of the fork member 65 downward while moving the bucket base 62 rearward with respect to the unit base 61 so that, as shown in FIG. 13, the commodity supporting portion 65a is inserted to an area below the commodity A positioned at the front end side of the commodity storage column 50. At this time, as shown in FIG. 14, the gate release portion 62c of the bucket base 62 contacts the bottom surface of the gate plate 54 of the commodity storage column 50, the gate plate 54 is rotated upward by the rearward movement of the bucket base 62, to thereby

open the front end side of the commodity passage 50a of the commodity storage column 50. Further, positioning in the width direction of the bucket unit 60 with respect to the commodity storage column 50 is carried out by one end side in the width direction of the gate release portion 62c contacting with the gate plate 54 and the other end side in the width direction of the gate release portion 62c contacting with the guide portion 52a. Next, as shown in FIG. 15, the bucket unit 60 is moved upward by the unit moving device 70 so that the commodity A is lifted by the fork member 65 to receive the commodity A inside the bucket 64. At this time, since the top surface of the fork member 65 forms a downward slope from the front edge side to the base end side thereof, as shown in FIG. 16, the commodity A that is lifted upward tilts forward so that it moves forward and is received inside the bucket 64. As shown in FIG. 17, the bucket unit 60 that receives the commodity A moves the bucket base 62 forward with respect to the unit base 61 and, as shown in FIG. 18, raises the commodity supporting portion 65a of the fork member 65 upward to incline the commodity A to the bucket 64 side. Thereafter, when the bucket base 62 is moved further forward, as shown in FIG. 19, the bucket 64 rotates to the commodity outlet portion 14 side. At this time, when the bucket base 62 moves forward with respect to the unit base 61, the rotating member 63 contacts against the protrusion 61c of the unit base 61 and changes orientation by 90° to the commodity outlet portion 14 side, and as a result the bucket 64 rotates towards the commodity outlet portion 14. Further, when rotating the bucket 64 to the commodity outlet portion 14 side, by rotating the bucket 64 while the bucket 64 contacts against the abutting portion 62b, the angle of inclination of the bucket 64 at the front end of the automatic vending machine main unit 10 is made small and the angle of inclination of the bucket 64 in a state in which the bucket 64 faces the commodity outlet portion 14 side is made large. Next, in a state in which the bucket 64 faces the commodity outlet portion 14 side, as shown in FIG. 20, the bucket unit 60 containing the commodity A is moved in the vertical direction and width direction by the unit moving device 70 to move to the commodity carrying out position. Subsequently, by movement in the width direction of the unit moving device 70, as shown in FIG. 21, the restriction releasing member 68 contacts against the operating portion 16 provided adjacent to the opening 15 of the commodity outlet portion 14 and moves diagonally upward to thereby move the rotation restricting member 66 upward. This movement releases the restriction on rotation of the fork member 65 so that the fork member 65 rotates downward and the received commodity A is carried out in a diagonally downward direction. Further, when the rotation restricting member 66 moves upward, as shown in FIG. 22, the rotation restricting member 66 contacts against the abutting portion 67a of the commodity detecting plate 67 to cause the commodity detecting plate 67 to rotate. As a result, the commodity A in the bucket 64 is pushed out in a diagonally upward direction

so that the commodity A is reliably carried out to the commodity outlet portion 14. The bucket unit 60 from which the commodity A has been carried out is then moved to the predetermined standby position by the unit moving device 70 to complete the operation.

[0030] Thus, according to the commodity carrying out device of the present embodiment, a commodity A that is located at the front end side of the commodity storage column 50 is tilted forward and moved into the bucket 64. As a result, when moving a vertically-long shaped commodity A in an upright state into the bucket 64, the commodity A can be moved without the commodity A toppling backwards. Therefore, the commodity A can be reliably moved into the bucket 64.

[0031] Further, a commodity A that is located at the front end side of the commodity storage column 50 is tilted forward and moved inside the bucket 64 by means of a fork member 65 for supporting the bottom surface of the commodity A that is arranged on the bucket 64 side so that the top surface thereof forms a downward slope from the commodity storage column 50 side towards the bucket 64 side, a notch portion 51b which is provided at the front end side of the commodity storage column 50 and through which a commodity supporting portion 65a of the fork member 65 can pass, and a unit moving device 70. It is thus possible to tilt the commodity A to move the commodity A inside the bucket 64 by moving the bucket unit 60 upward from below. Therefore, production costs can be reduced since a complicated mechanism is not necessary.

[0032] The commodity carrying out device of the present embodiment also comprises a gate plate 54 which is provided in a vertically rotatable condition at the front end side of the commodity storage column 50 and which opens and closes the front end side of the commodity passage 50a, a gate release portion 62c which is arranged so as to extend to the commodity storage column 50 side in the bucket base 62 and which contacts against the gate plate 54 upon movement to the commodity storage column 50 side of the bucket base 62 to rotate the gate plate 54 in a direction that opens the front end side of the commodity passage 50a, and a guide portion 52a which is provided on the commodity storage column 50 side and which guides the gate release portion 62c in the front-to-rear direction when the gate release portion 62c rotates the gate plate 54 to open the front end side of the commodity passage 50a. It is thereby possible to open the commodity passage 50a by movement in the front-to-rear direction of the bucket base 62 and also restrict displacement in the width direction of the bucket unit 60 with respect to the commodity storage column 50 and guide the bucket unit 60 in the front-to-rear direction. Consequently, costs can be decreased since a motive power is not separately required to open the commodity passage 50a, and positioning of the bucket unit 60 with respect to the commodity storage column 50 can also be easily performed.

[0033] The fork member 65 is arranged to rotate in a

direction that forms a downward slope towards the bucket 64 side when the bucket 64 is moved forward. Since it is thereby possible to tip a commodity A that is received inside the bucket 64 back further to the bucket 64 side, the commodity A can be received in a more stable state inside the bucket 64.

[0034] Further, by means of a pair of rails 61d provided on the unit base 61 and a pair of grooves 65b provided on the fork member 65, movement in the width direction of the fork member 65 is restricted to guide the fork member 65 in the front-to-rear direction. Since it is thereby possible to reliably position the fork member 65 in the width direction with respect to the commodity storage column 50, the length dimensions of the commodity supporting portion 65a of the fork member 65 can be increased to accommodate a commodity A that has large outer diameter dimensions.

[0035] The notch portion 53a that permits movement in the vertical direction of the commodity supporting portion 65a of the fork member 65 is provided in the ejecting plate 53. It is thereby possible to prevent contact with the ejecting plate 53 by the commodity supporting portion 65a of the fork member 65 when the ejecting plate 53 is positioned at the front end side of the commodity passage 50a, and thus it is also possible to accommodate carrying out of a commodity A with small outer diameter dimensions.

[0036] The commodity carrying out device of the present embodiment also comprises a commodity detecting plate 67 and a commodity detecting sensor 61e for detecting the existence or non-existence of a commodity A inside the bucket 64. It is therefore possible to detect when a commodity A is sold out or when a fault occurs in an operation to carry out a commodity A. Thus, when a commodity A of a predetermined commodity storage column 50 is sold out the commodity A of a different commodity storage column 50 can be carried out, and in the case of a failure to receive a commodity A in the bucket 64, the carrying out operation is performed again so that the commodity A can be definitely sold.

[0037] Each shelf 40 is disposed so that the dimensions of a space between vertically adjacent shelves 40 are substantially the same as the height dimensions of the commodity A. A space necessary for operations to receive a commodity A in the bucket 64 is provided at the front of each shelf 40. It is thereby possible to prevent defective carrying out due to erroneous storage of a commodity that has larger height dimensions than the height dimensions of the commodity A that is intended to be stored.

[0038] FIG. 23 and FIG. 24 are views that illustrate a second embodiment of the present invention. In the figures, components that are the same as those of the above described embodiment are denoted by the same reference symbols.

[0039] In this automatic vending machine, the fork member 65 is provided so that the top surface of the commodity supporting portion 65a is rotatable from a

state in which the top surface lies in a substantially horizontal plane to a direction in which the top surface forms a downward slope towards the bucket 64 side. Further, in the notch portion 51b of the base plate 51 of the commodity storage column 50 is provided an abutting portion 51c that contacts against the fork member 65 to rotate the fork member 65 when the bucket unit 60 is moved downward.

[0040] In the automatic vending machine arranged as described above, when receiving a commodity A located at the front end side of the commodity storage column 50 into the bucket 64, the bucket unit 60 is moved rearward to insert the commodity supporting portion 65a of the fork member 65 into the notch portion 51b of the commodity storage column 50, and the bucket unit 60 is then moved downward. As a result, the bottom surface of the fork member 65 contacts against the abutting portion 51c to thereby rotate the fork member 65, and the top surface of the fork member 65 inclines to the bucket 64 side while lifting the commodity A. Thus, the commodity A is tilted to the bucket 64 side and moves to the bucket 64 side to thereby receive the commodity A in the bucket 64.

[0041] Thus, according to the commodity carrying out device of the present embodiment, a commodity A positioned at the front end side of a commodity storage column 50 is tilted forward and moved into the bucket 64 by means of the fork member 65 provided in a condition in which the angle of inclination of the top surface of the commodity supporting portion 65a is changeable from a state in which the top surface lies in a substantially horizontal plane to a direction in which the top surface forms a downward slope towards the bucket 64 side, and the abutting portion 51c that causes the top surface of the commodity supporting portion 65a to incline to the bucket 64 side by contacting against the fork member 65 from below when the bucket unit 60 is moved downward. As a result, the commodity A can be tilted forward and moved into the bucket 64 by moving the bucket unit 60 downward. Therefore, production costs can be reduced since a complicated mechanism is not necessary.

[0042] FIG. 25 and FIG. 26 are views that illustrate a third embodiment of the present invention. In the figures, components that are the same as those of the above described embodiments are denoted by the same reference symbols.

[0043] In this automatic vending machine, the top surface of the commodity supporting portion 65a of the fork member 65 is provided in a condition in which the top surface can be rotated from a state in which the top surface forms a slightly downward slope to the bucket 64 side with respect to the horizontal plane to a direction in which the angle of inclination to the bucket 64 side increases. Further, an abutting portion 51d is provided in the notch portion 51b of the base plate 51 of the commodity storage column 50. The abutting portion 51d contacts against the bottom surface of the fork member 65 to thereby cause the fork member 65 to rotate when the bucket unit 60 moves horizontally to the commodity stor-

age column 50 side.

[0044] In the automatic vending machine arranged as described above, when receiving a commodity A located at the front end side of the commodity storage column 50 into the bucket 64, the bucket unit 60 is moved rearward to insert the tip of the commodity supporting portion 65a of the fork member 65 into the notch portion 51b of the commodity storage column 50. As a result, the bottom surface of the fork member 65 contacts against the abutting portion 51d to thereby rotate the fork member 65, and the top surface of the fork member 65 inclines further to the bucket 64 side while lifting the commodity A. Thus, the commodity A is tilted to the bucket 64 side and moves to the bucket 64 side to thereby receive the commodity A in the bucket 64.

[0045] Thus, according to the commodity carrying out device of the present embodiment, a commodity A positioned at the front end side of the commodity storage column 50 is tilted forward and moved into the bucket 64 by means of the fork member 65 provided in a condition in which the angle of inclination thereof is changeable from a state in which the top surface of the commodity supporting portion 65a forms a slightly downward slope to the bucket 64 side with respect to the horizontal plane to a direction in which the angle of inclination to the bucket 64 side increases, and an abutting portion 51d that causes the top surface of the commodity supporting portion 65a to incline to the bucket 64 side by contacting against the fork member 65 from below when the bucket unit 60 is moved towards the commodity storage column 50 side. As a result, the commodity A can be tilted forward and moved into the bucket 64 by moving the bucket unit 60 to the commodity storage column 50 side. Therefore, production costs can be reduced since a complicated mechanism is not necessary.

[0046] FIG. 27 and FIG. 28 are views that illustrate a fourth embodiment of the present invention. In the figures, components that are the same as those of the above described embodiments are denoted by the same reference symbols.

[0047] This automatic vending machine is arranged so that the top surface of the commodity supporting portion 65a of the fork member 65 forms a downward slope towards the bucket 64 side. Further, at the front end side of the base plate 51 of the commodity storage column 50 is provided a movable portion 55 that is rotatable from a state in which the top surface thereof lies in a substantially horizontal plane to a direction in which the top surface forms a downward slope towards the bucket 64 side. The movable portion 55 is arranged so as to be rotated by an unshown electric motor or a link mechanism or the like.

[0048] In the automatic vending machine arranged as described above, when receiving a commodity A located at the front end side of the commodity storage column 50 into the bucket 64, the bucket unit 60 is moved to dispose the tip of the commodity supporting portion 65a of the fork member 65 below the commodity storage col-

umn 50, and the movable portion 55 is rotated to incline the top surface thereof to the bucket 64 side. Thereby, the commodity A on the movable portion 55 is tilted to the bucket 64 side and moves to the bucket 64 side so that the commodity A is received in the bucket 64.

[0049] Thus, according to the commodity carrying out device of the present embodiment, a commodity A positioned at the front end side of the commodity storage column 50 is tilted forward and moved into the bucket 64 by means of the movable portion 55 provided at the front end side of the base plate 51 of the commodity storage column 50 in a condition in which an angle of inclination thereof is changeable from a state in which the top surface lies in a substantially horizontal plane to a state in which the top surface forms a downward slope to the bucket 64 side. As a result, the commodity A can be tilted forward and moved into the bucket 64 by rotating the movable portion 55 downward. Therefore, production costs can be reduced since a complicated mechanism is not necessary.

[0050] According to the above described embodiment, a configuration was illustrated in which the commodity detecting sensor 61e that is turned on/off by the commodity detecting plate 67 is provided in the unit base 61. However, even when the commodity detecting sensor 61e is provided in the bucket 64, the commodity detecting sensor 61e can similarly detect when a commodity A is sold out or when a fault occurs during an operation to carry out a commodity A. When the commodity A of a predetermined commodity storage column 50 is sold out, the commodity A of a different commodity storage column 50 can be carried out, and in the case of a failure to receive a commodity A in the bucket 64, the carrying out operation is performed again so that the commodity A can be definitely sold.

[0051] The embodiments described in the present specification are exemplary embodiments of the present invention and are not intended to limit the present invention. It should be understood that the scope of this invention is defined by the attached claims, and all modifications within the meaning of those claims are included in the present invention.

Claims

1. A commodity carrying out device, comprising:

- a plurality of commodity storage columns (50) aligned in a vertical direction and a width direction with respect to each other for storing commodities (A) side by side in a front-to-rear direction;
- a bucket (64) for receiving a commodity (A) to be carried out;
- a bucket moving mechanism (70) for moving the bucket (64) to a front side of an arbitrary commodity storage column (50) and moving the

- bucket (64) that receives the commodity (A) to a predetermined commodity carrying out position; and
 a commodity reception mechanism for tilting a commodity (A) positioned at a front end side of the commodity storage column (50) to a bucket (64) side to move the commodity (A) into the bucket (64).
2. The commodity carrying out device according to claim 1, wherein
 the commodity reception mechanism includes: a commodity supporting member (65) for supporting a bottom surface of a commodity (A), that is provided on the bucket (64) side so that a top surface thereof forms a downward slope from the commodity storage column (50) side to the bucket (64) side; a notch (51b) for allowing the commodity supporting member (65) to pass therethrough in a vertical direction, that is provided at the front end side of the commodity storage column (50); and a bucket moving mechanism (70) for moving the bucket (64) in the vertical direction.
3. The commodity carrying out device according to claim 1, wherein
 the commodity reception mechanism includes: a commodity supporting member (65) for supporting a bottom surface of a commodity (A), that is provided in the bucket (64) in a condition in which an angle of inclination thereof is changeable from a state in which a top surface thereof lies in a substantially horizontal plane to a direction in which the top surface forms a downward slope towards the bucket (64) side; an abutting portion (51c) that is provided at the front end side of the commodity storage column (50), for causing the top surface of the commodity supporting member (65) to incline to the bucket (64) side by contacting against the commodity supporting member (65) from below when the bucket (64) is moved downward; and a bucket moving mechanism (70) for moving the bucket (64) in the vertical direction.
4. The commodity carrying out device according to claim 1, wherein
 the commodity reception mechanism includes: a commodity supporting member (65) for supporting a bottom surface of a commodity (A), that is provided in the bucket (64) in a condition in which an angle of inclination is changeable from a state in which a top surface thereof forms a slightly downward slope to the bucket (64) side with respect to the horizontal plane to a direction in which an angle of the downward slope to the bucket (64) side increase; an abutting portion (51d) provided at a front end side of the commodity storage column (50) for causing the top surface of the commodity supporting member (65)
- to incline to the bucket (64) side by contacting against the bottom surface of the commodity supporting member (65) that moves to the commodity storage column (50) side; and a bucket moving mechanism (61, 62) for moving the bucket (64) in the front-to-rear direction.
5. The commodity carrying out device according to claim 1, wherein:
 the commodity reception mechanism includes a movable portion (55) provided at the front end side at the bottom of the commodity storage column (50) in a condition in which an angle of inclination thereof can be changed from a state in which a top surface thereof is substantially horizontal to a state in which the top surface forms a downward slope towards the bucket (64) side.
6. The commodity carrying out device according to any one of claims 1 to 5, further comprising:
 a gate member (54) for opening and closing a front end side of a commodity passage (50a), that is provided in a vertically rotatable condition at the front end side of the commodity storage column (50);
 a gate release portion (62c) provided on the bucket (64) side for contacting against the gate member (54) accompanying movement of the bucket (64) to the commodity storage column (50) side, to thereby cause the gate member (54) to rotate in a direction that opens the front end side of the commodity passage (50a); and
 a guide portion (52a) provided on the commodity storage column (50) side for guiding the gate release portion (62c) in the front-to-rear direction when causing the gate member (54) to rotate to open the front end side of the commodity passage (50a).
7. The commodity carrying out device according to any one of claims 2 to 4, wherein:
 an angle of a downward slope to the bucket (64) side of the top surface of the commodity supporting member (65) increases by moving the bucket (64) forward.
8. The commodity carrying out device according to any one of claims 2 to 4, wherein:
 the commodity reception mechanism has a positioning mechanism (61d, 65b) for guiding the commodity supporting member (65) in the front-to-rear direction to restricts movement of the commodity supporting member (65) in the width direction.

9. The commodity carrying out device according to any one of claims 2 to 4, further comprising:

an ejecting member (53) provided in a condition in which the ejecting member (53) can move through a commodity passage (50a) of the commodity storage column (50), for causing commodities (A) that are arranged side by side in the commodity passage (50a) to move forward from a rear surface side, wherein;
the ejecting member (53) is provided with a notch (53a) that allows movement in the vertical direction of the commodity supporting member (65).

10. The commodity carrying out device according to any one of claims 1 to 5, wherein:

a commodity detection mechanism (61e, 67) that detects the existence or non-existence of a commodity (A) is arranged in the bucket (64).

11. The commodity carrying out device according to any one of claims 1 to 5, further comprising:

a plurality of shelves (40) that are aligned with respect to each other in the vertical direction and on which a plurality of commodity storage columns (50) are mountable in the width direction, wherein;
each shelf (40) is disposed so that a space between vertically adjacent shelves (40) is substantially the same as height dimensions of a commodity; and
a space necessary for operations for receiving a commodity A in the bucket (64) is provided at the front of each shelf (40).

Fig. 1

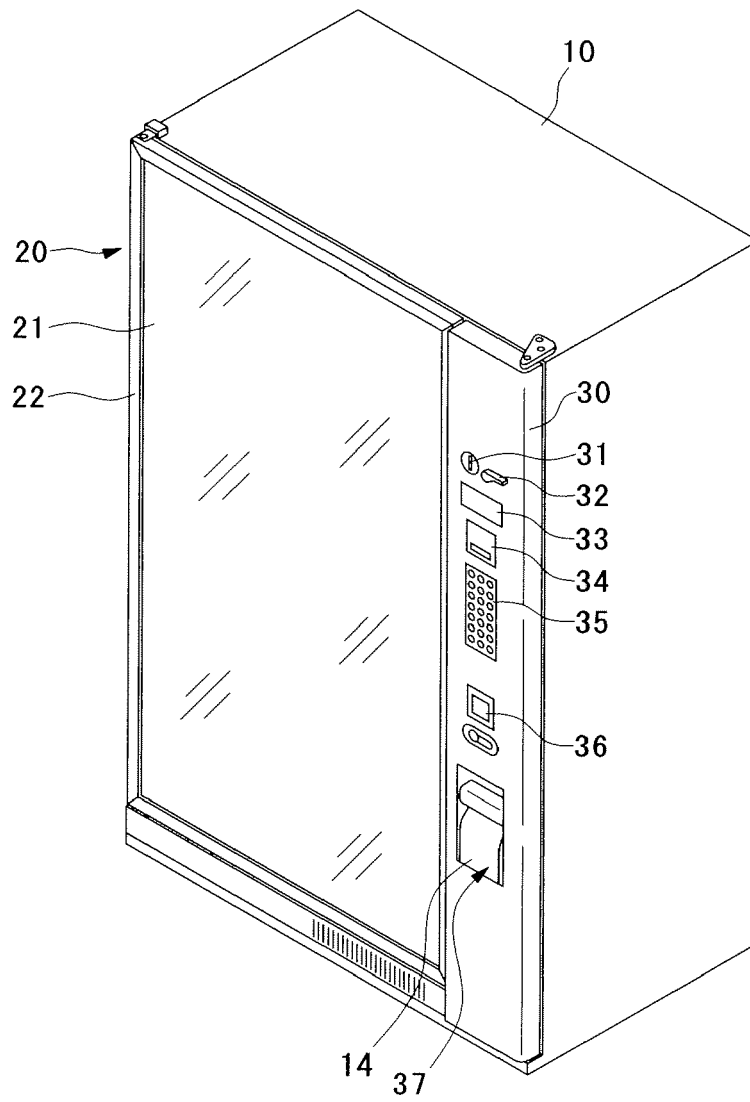

Fig. 2

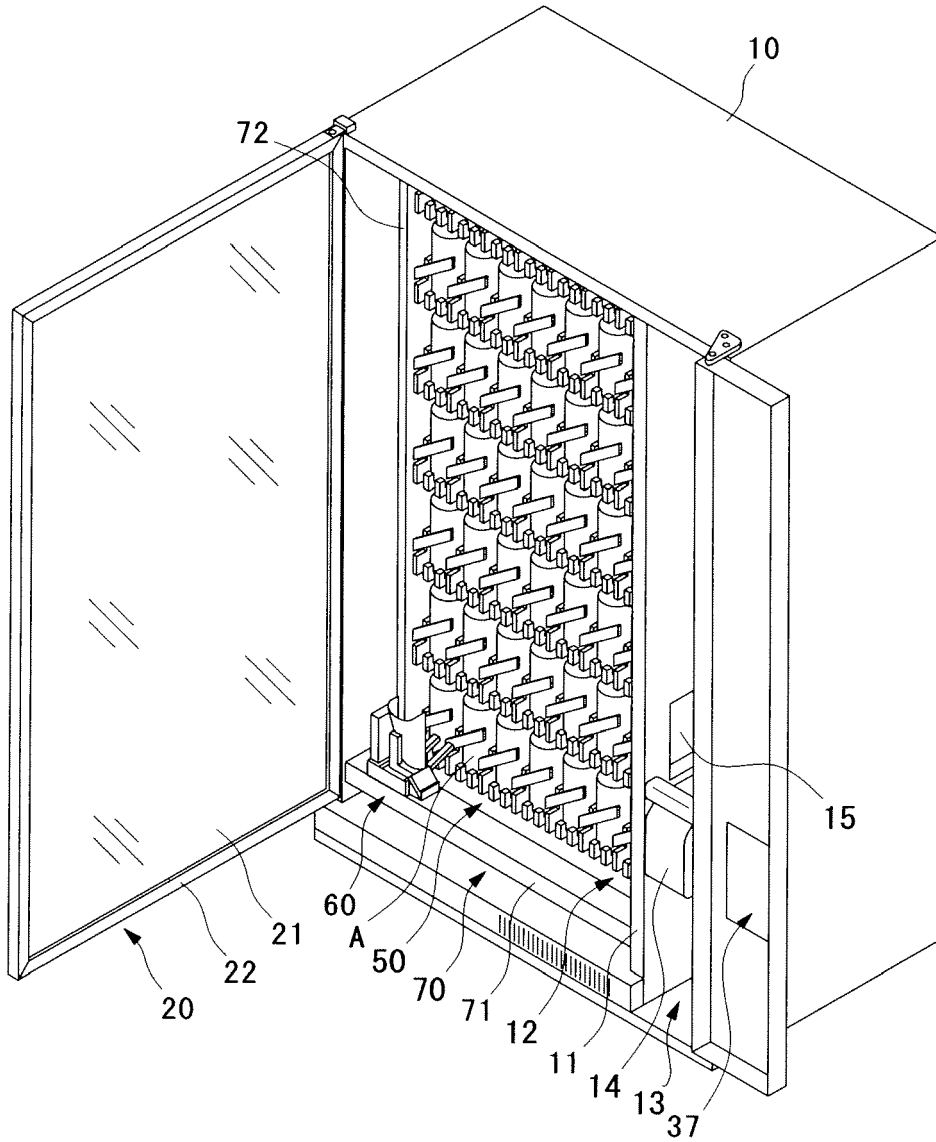

Fig. 3

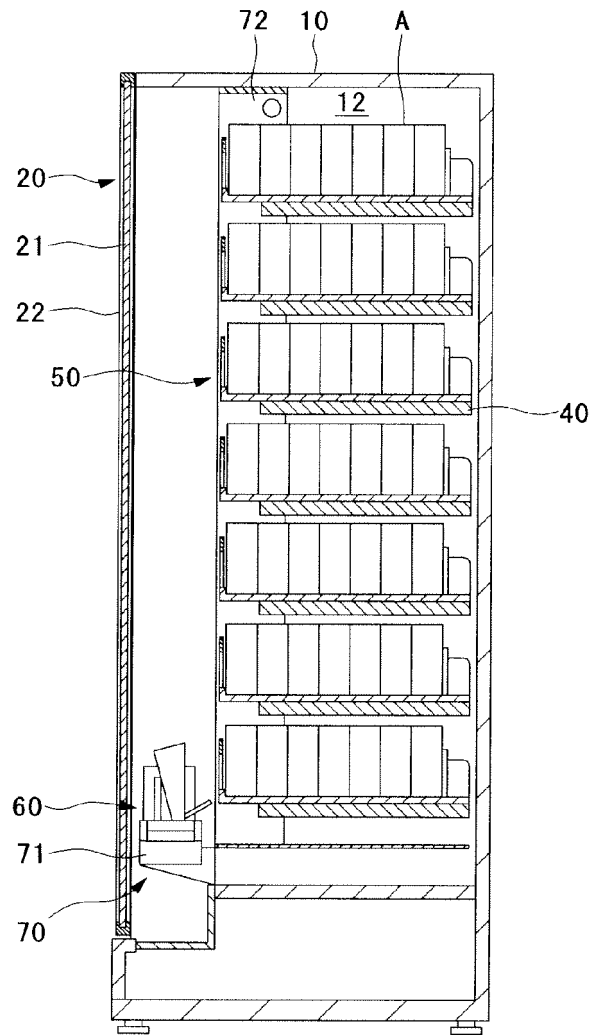

Fig. 4

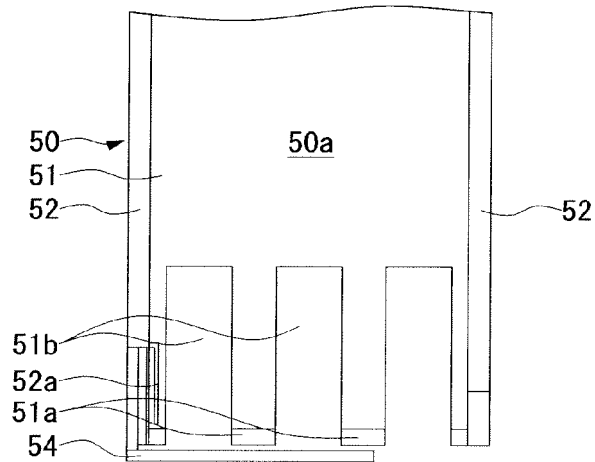

Fig. 5

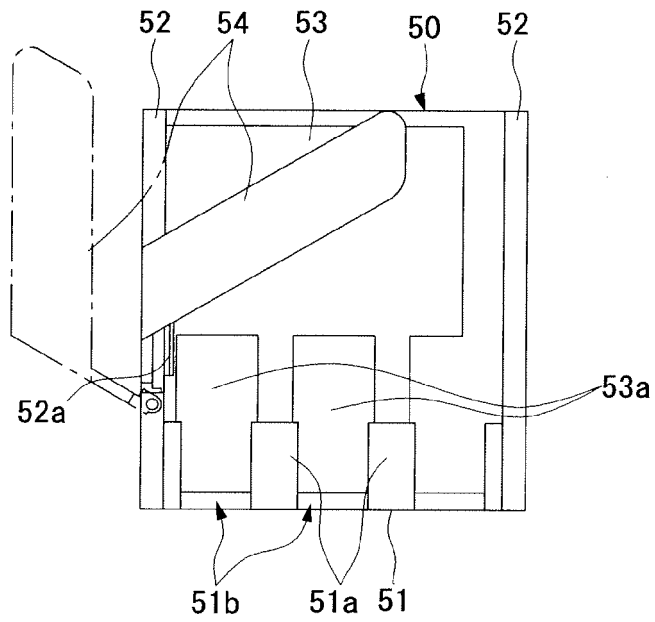

Fig. 6

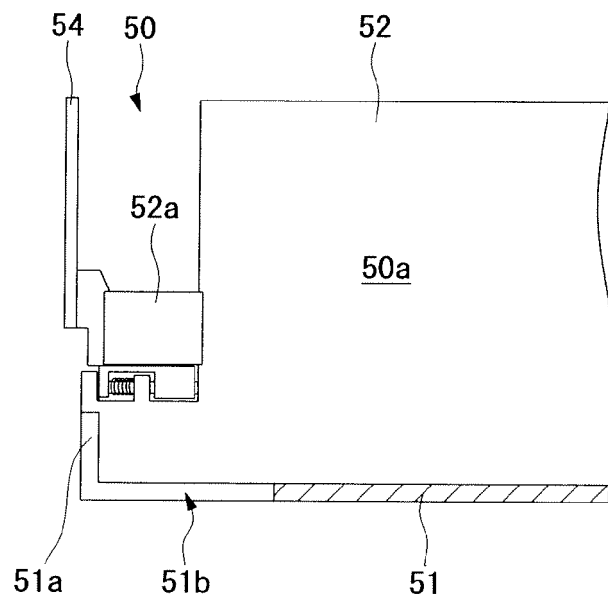

Fig. 7

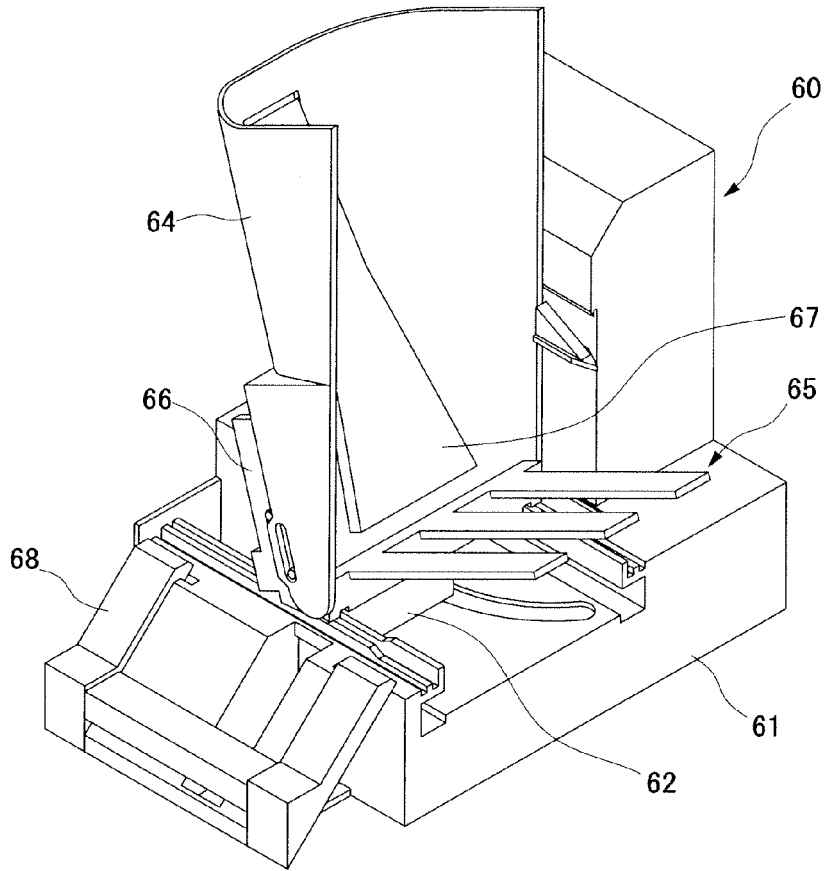

Fig. 8

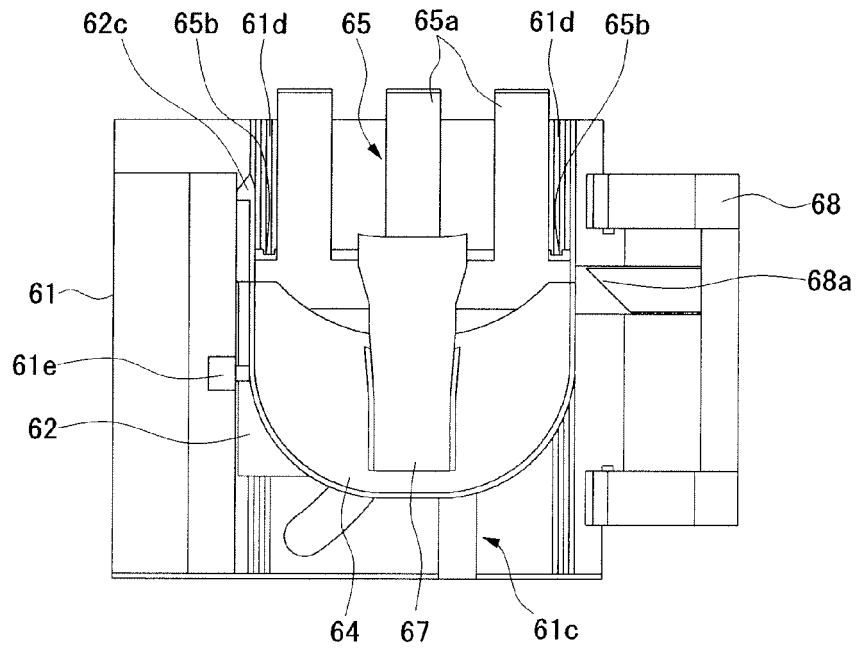

Fig. 9

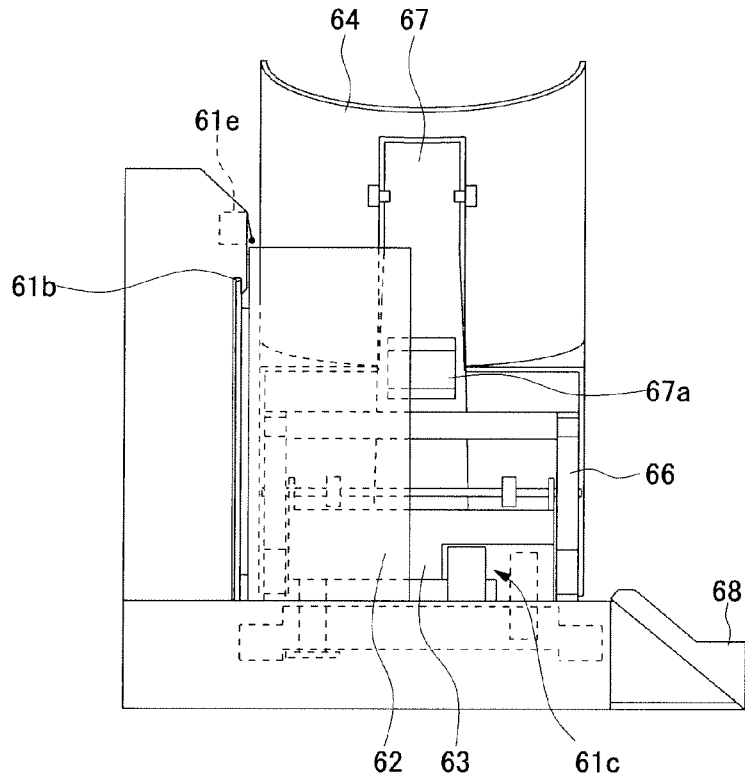

Fig. 10

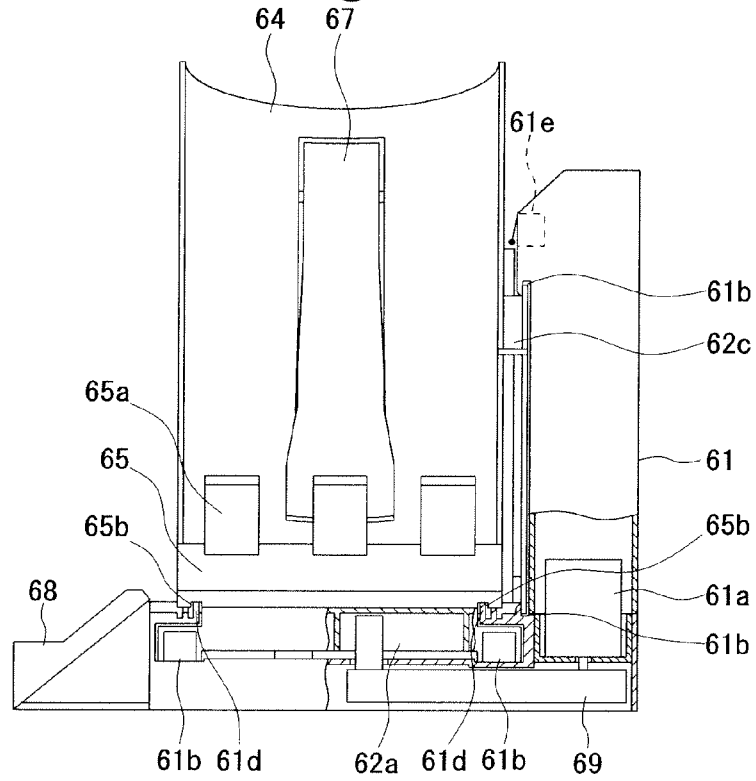

Fig. 11

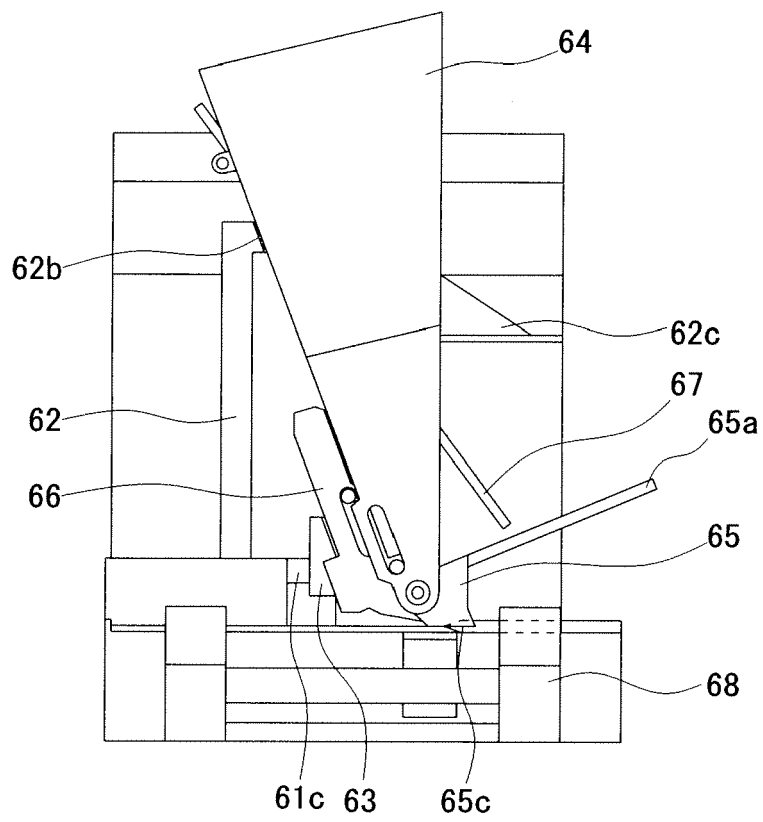

Fig. 12

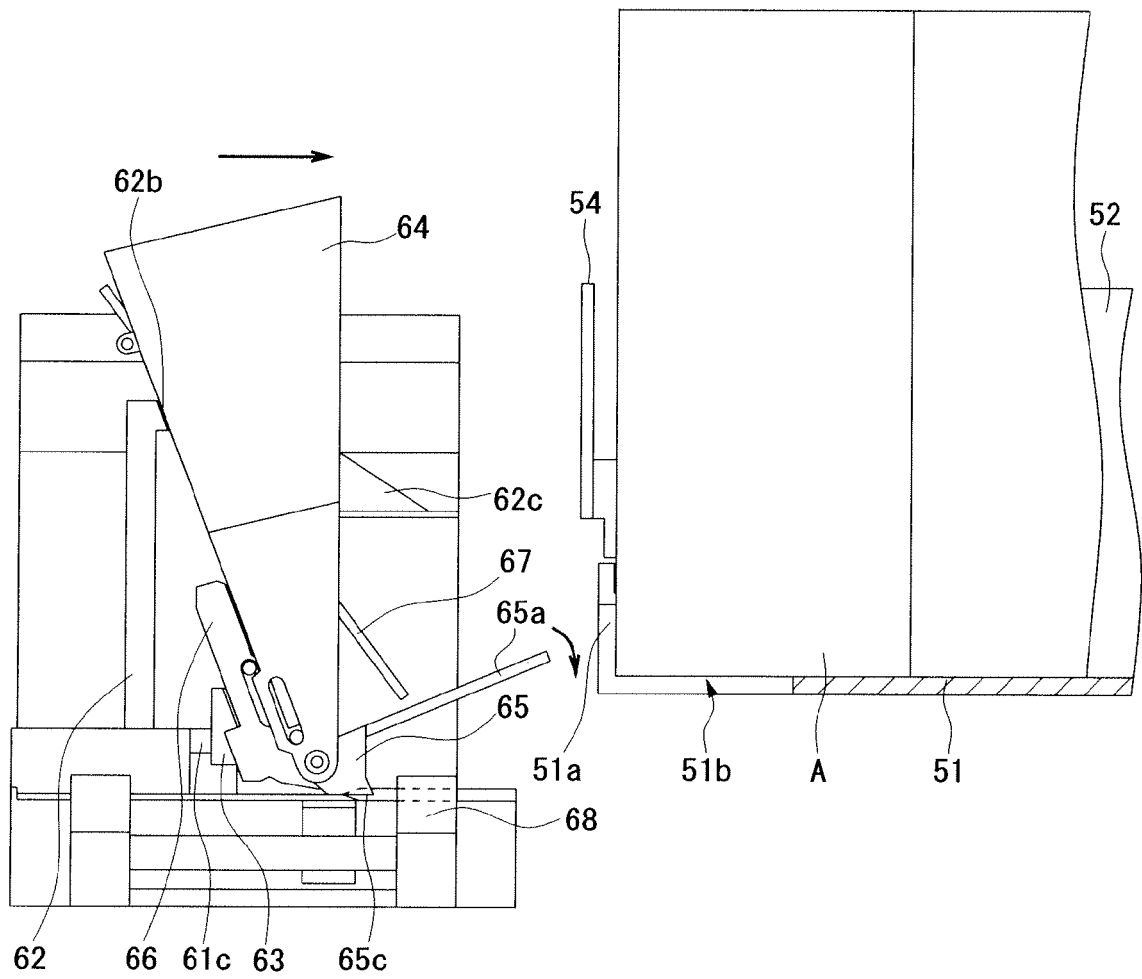

Fig. 13

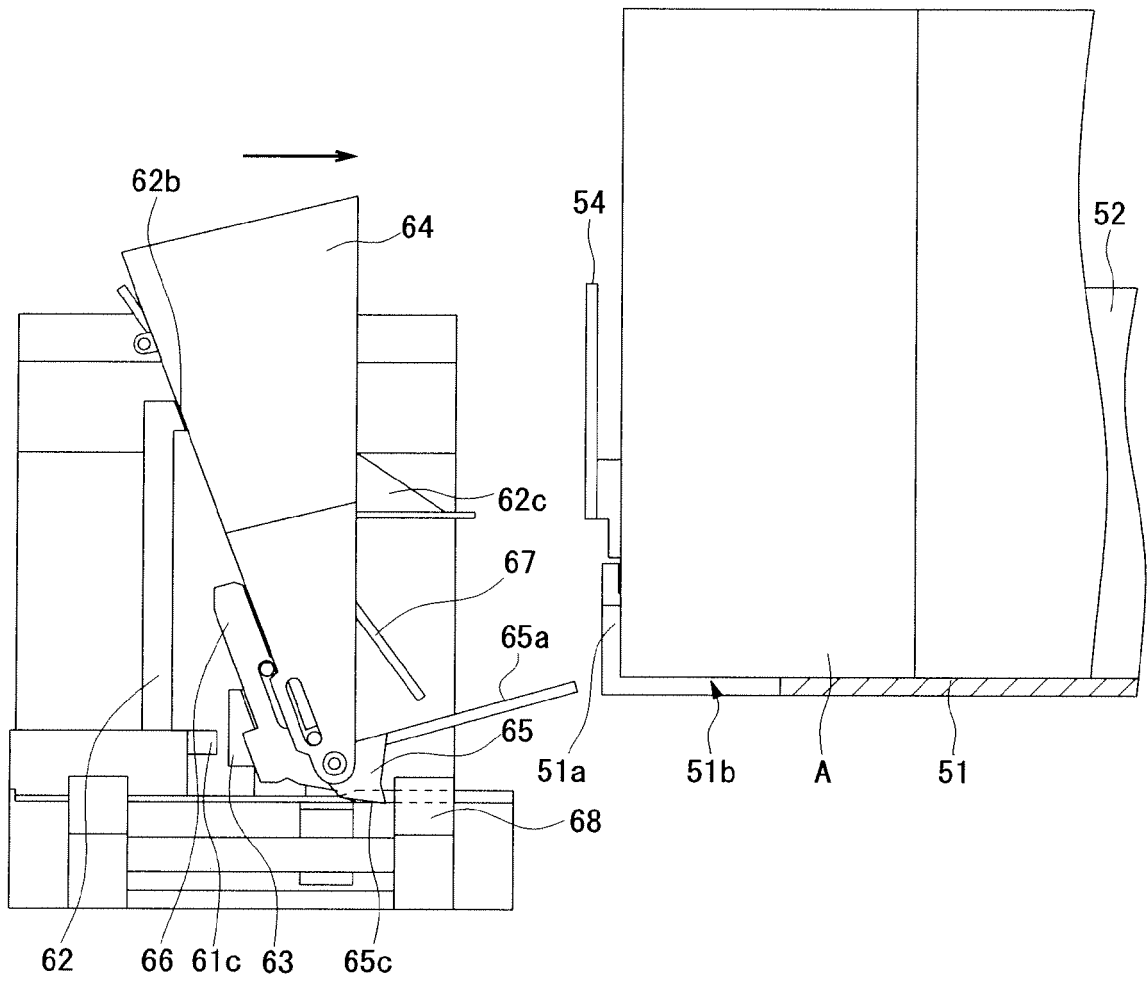

Fig. 14

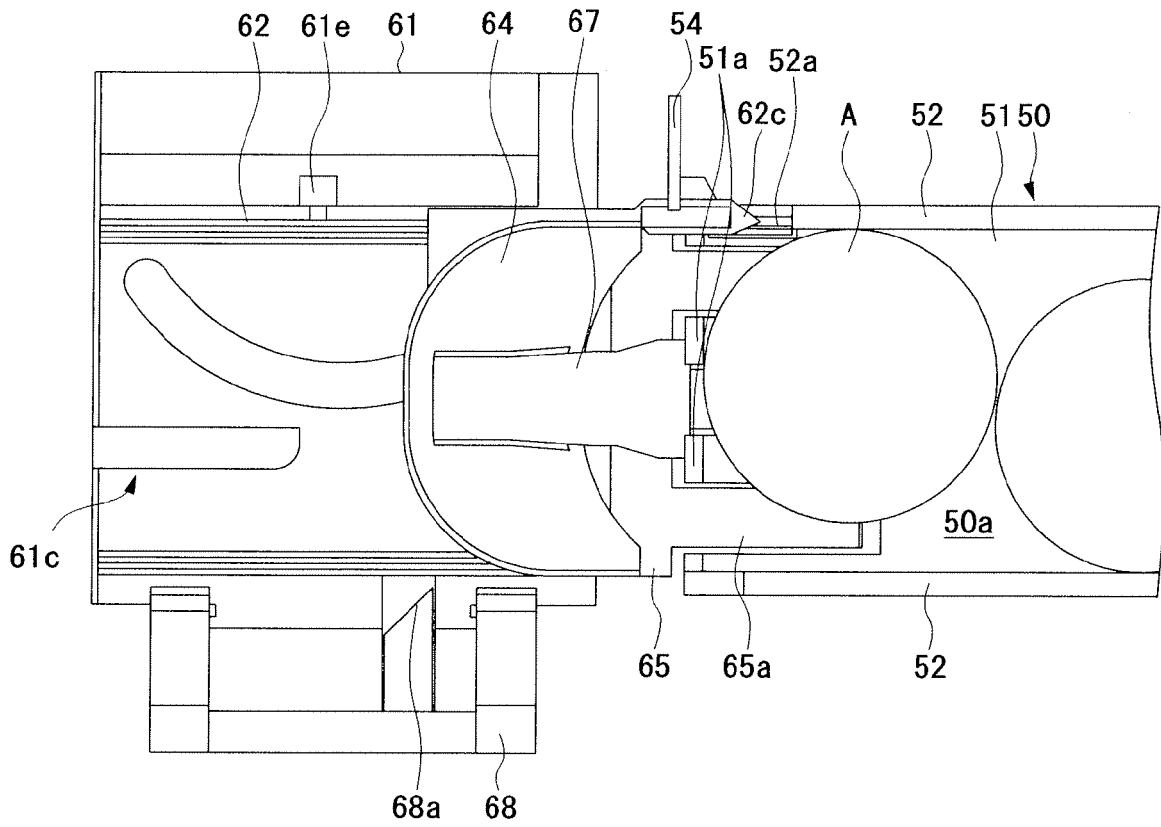

Fig. 15

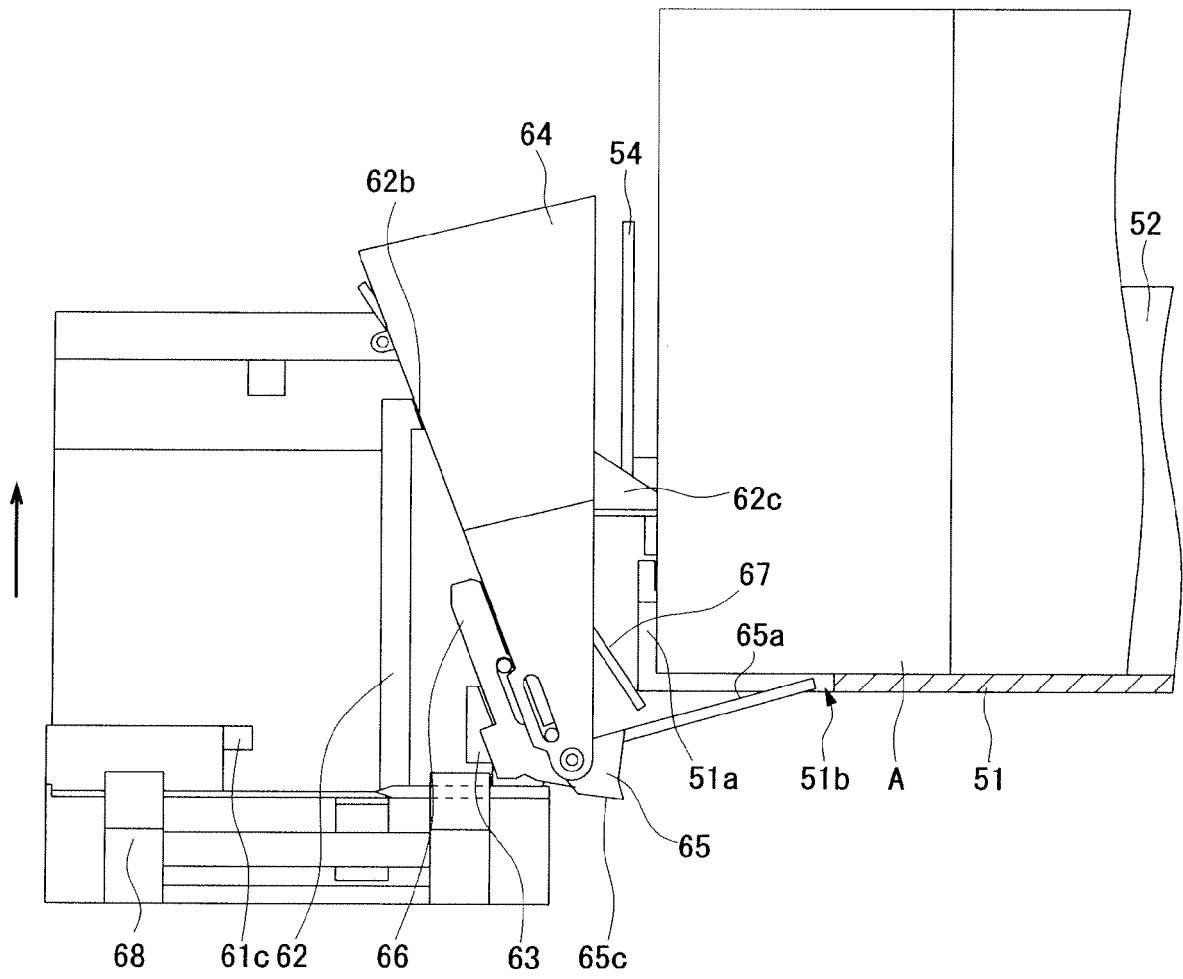

Fig. 18

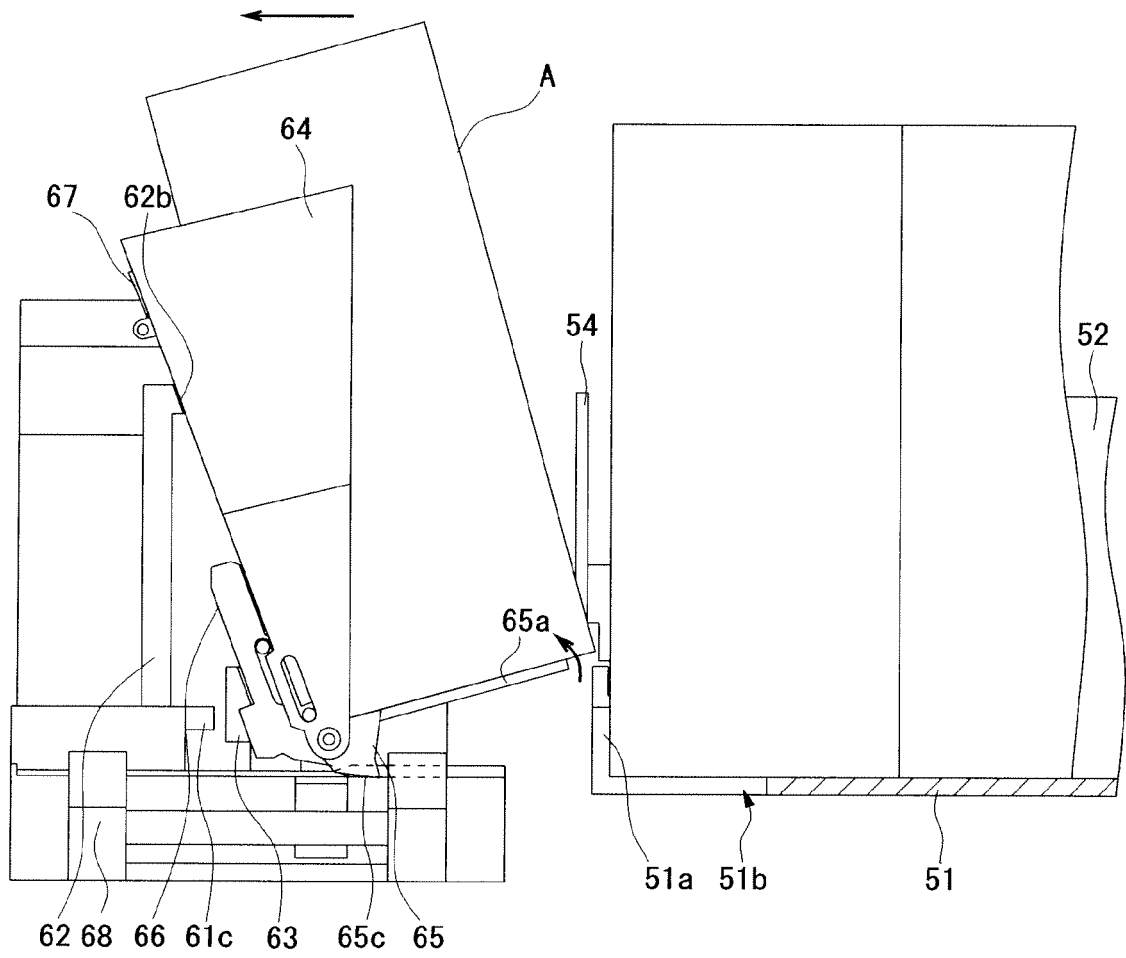

Fig. 19

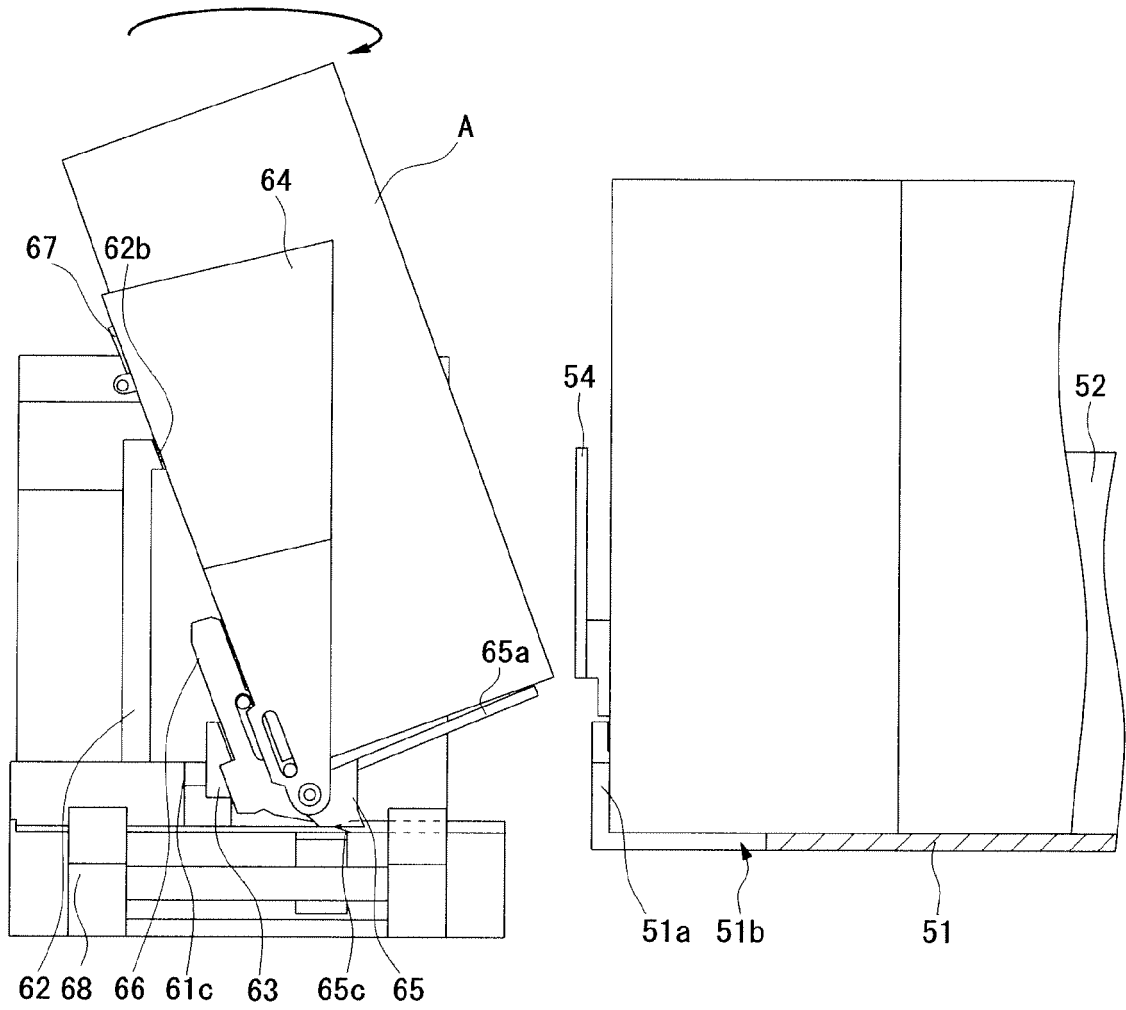

Fig. 20

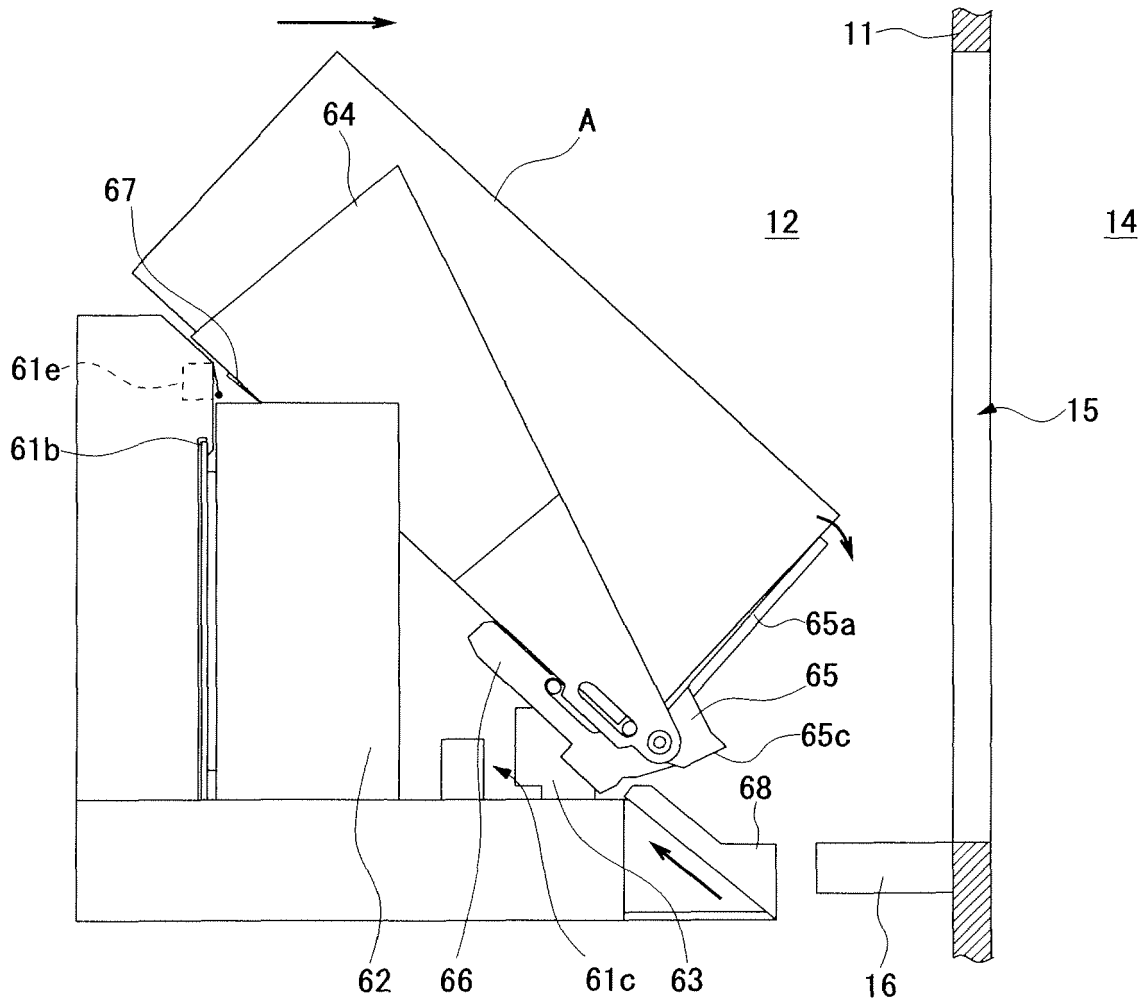
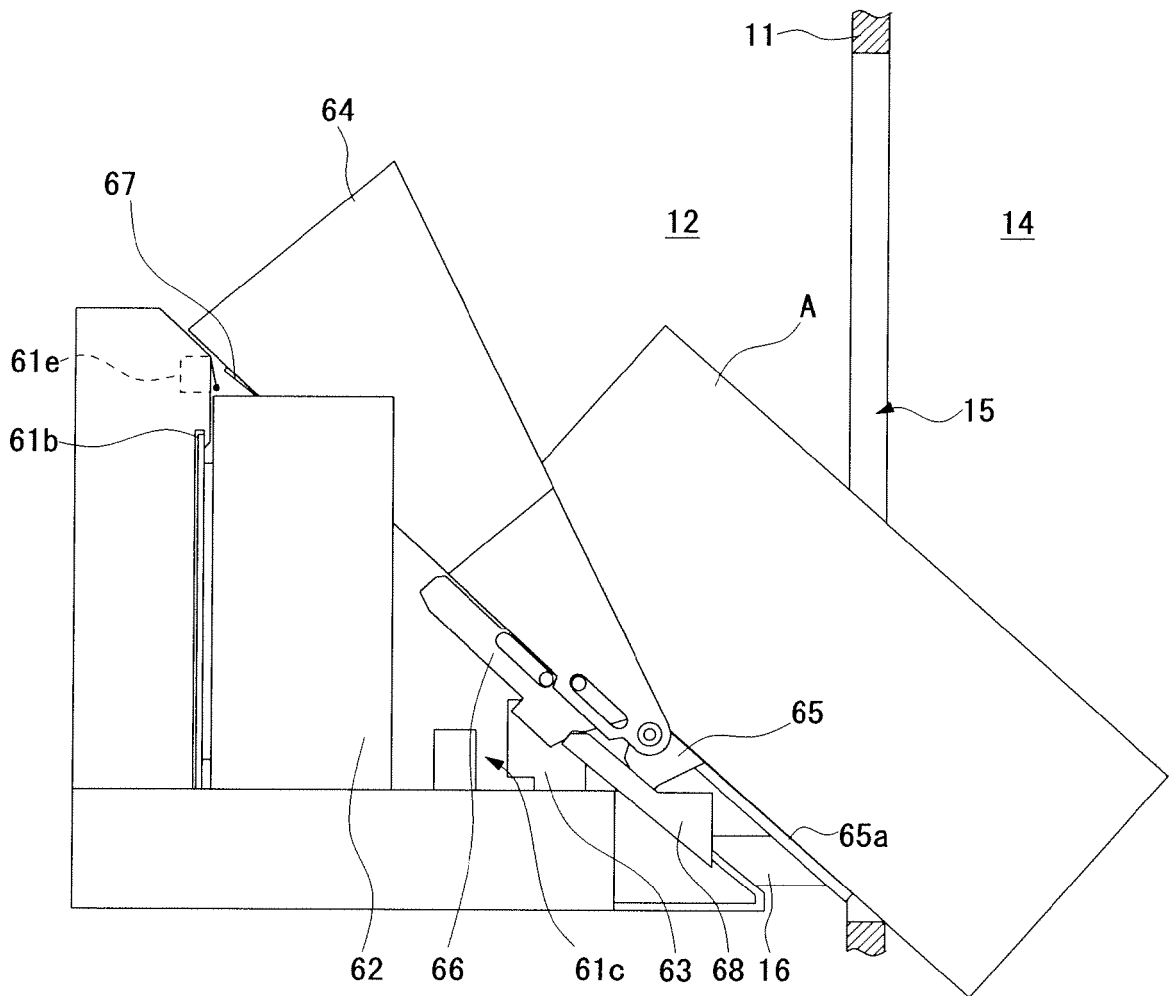

Fig. 21



F i g . 2 2

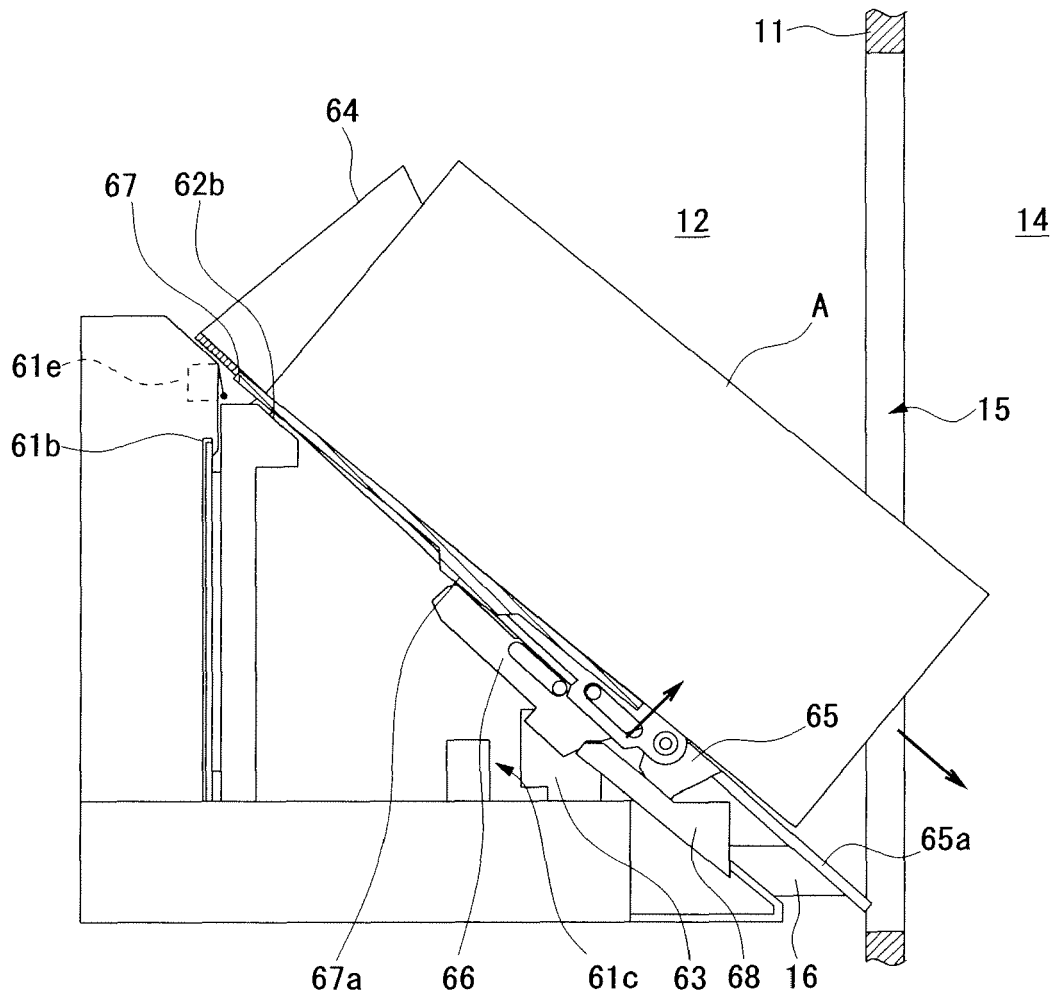

Fig. 23

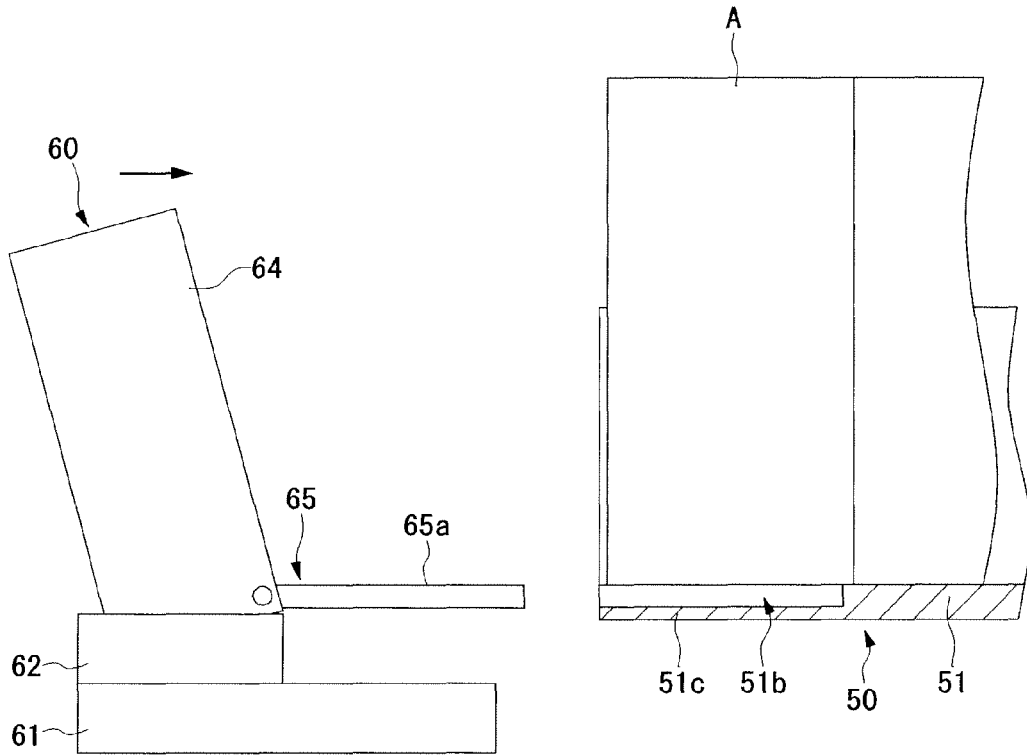

Fig. 24

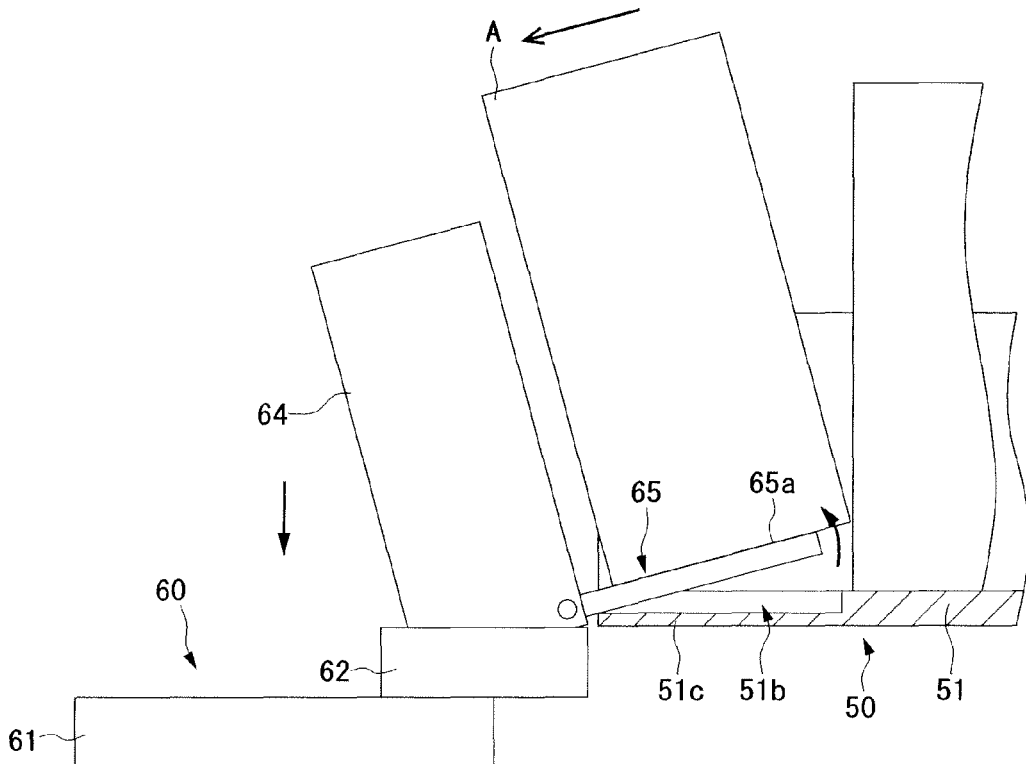

Fig. 25

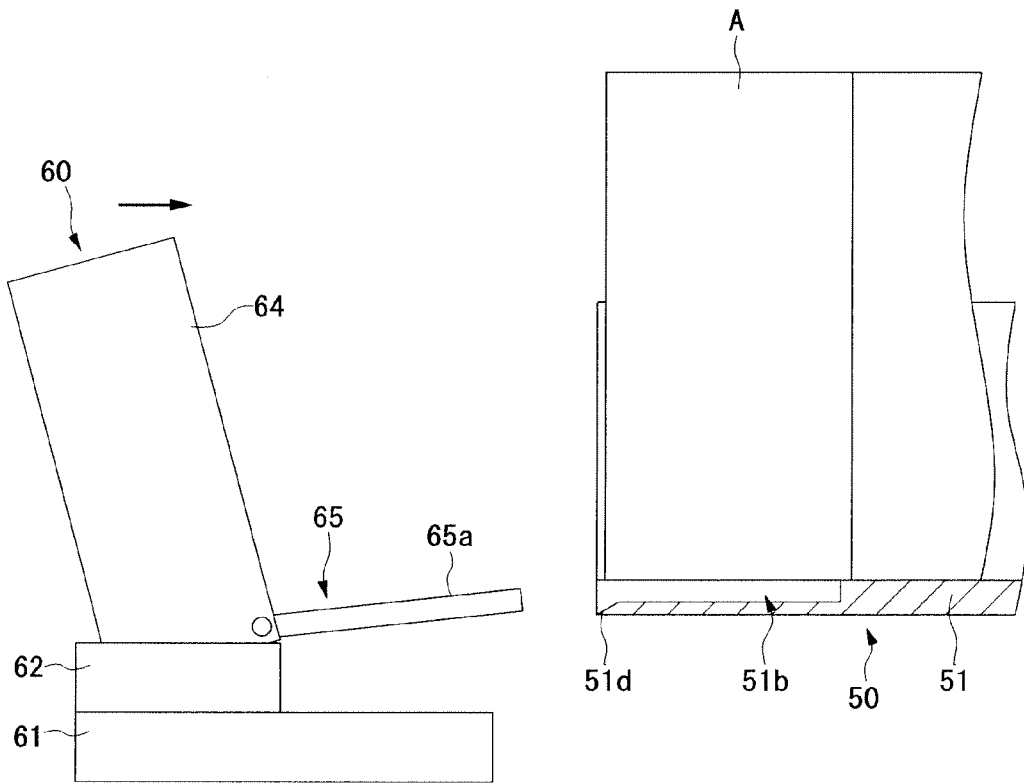

Fig. 26

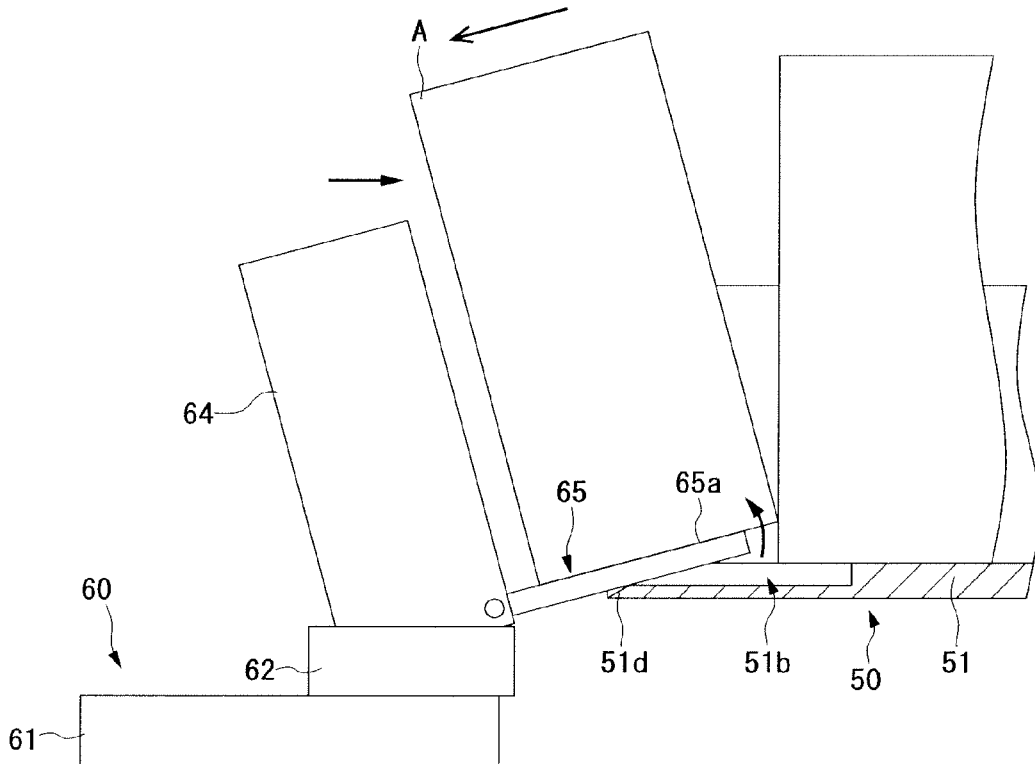

Fig. 27

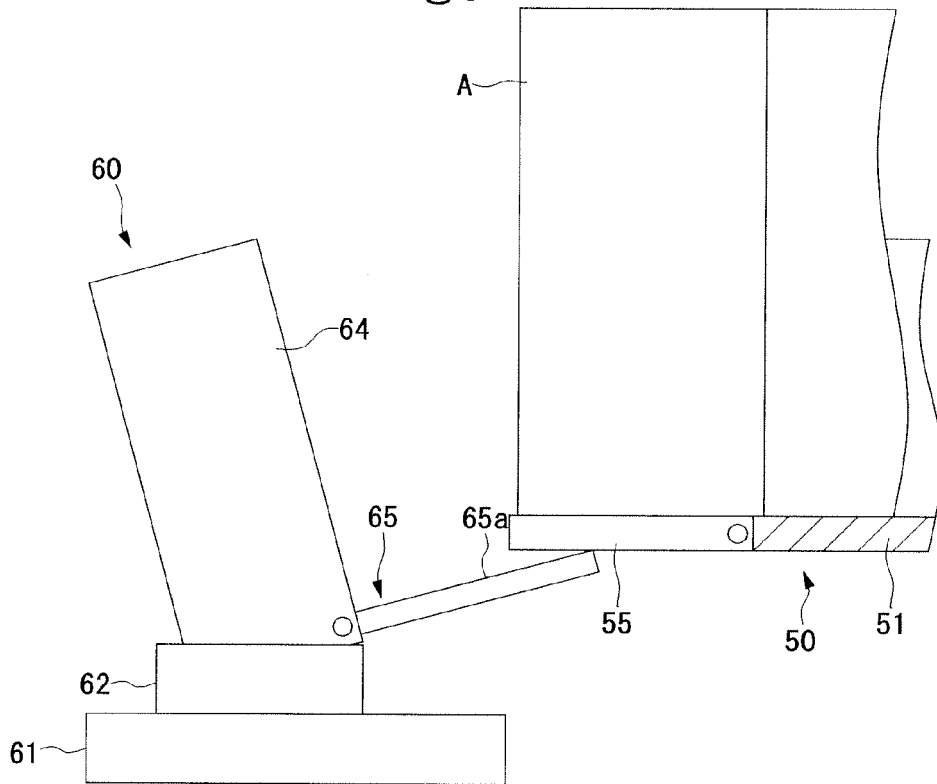

Fig. 28

