

G. F. MOORE & R. H. HURLBUT.

Machinery for Forming Counters for Boots and Shoes.

No. 198,551.

Patented Dec. 25, 1877.

Fig. 3.

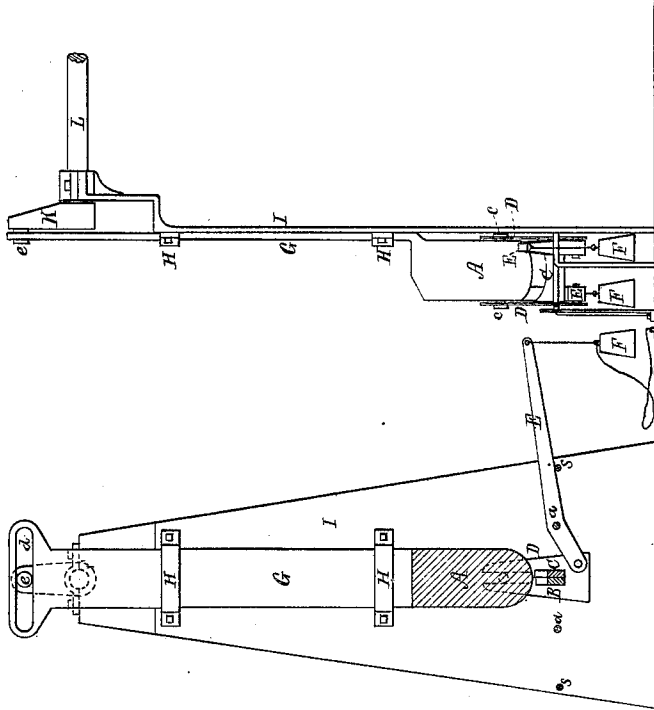

Fig. 2.

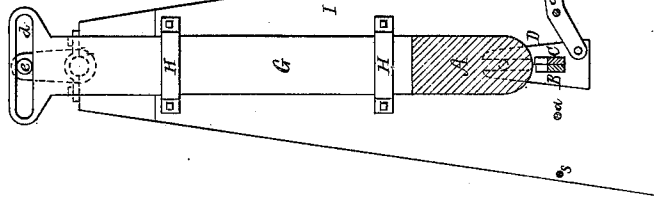

Fig. 4.

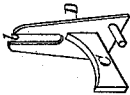
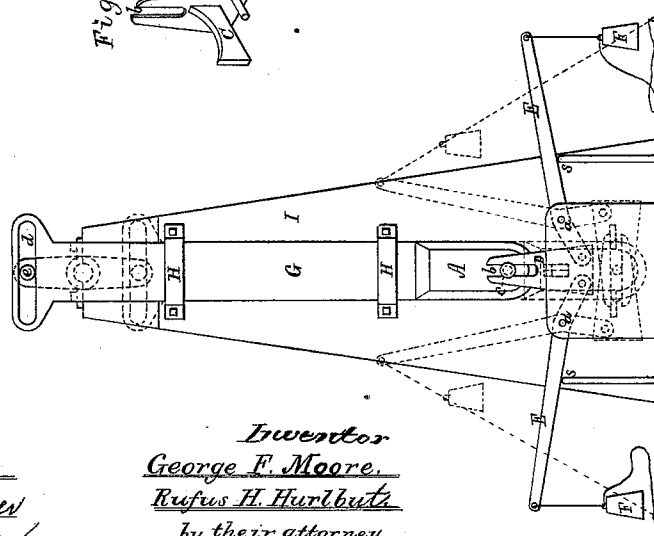

Fig. 1.



Witnesses.

*S. N. Piper*  
*L. P. Miller*

*Inventor*  
*George F. Moore,*  
*Rufus H. Hurlbut*  
*by their attorney.*  
*R. M. Eddy*

# UNITED STATES PATENT OFFICE.

GEORGE F. MOORE, OF KENNEBUNK, MAINE, AND RUFUS H. HURLBUT, OF SUDBURY, MASSACHUSETTS, ASSIGNORS TO MOUSAM MANUFACTURING COMPANY, OF KENNEBUNK, MAINE.

## IMPROVEMENT IN MACHINERY FOR FORMING COUNTERS FOR BOOTS AND SHOES.

Specification forming part of Letters Patent No. **198,551**, dated December 25, 1877; application filed November 27, 1877.

### *To all whom it may concern:*

Be it known that we, GEORGE F. MOORE, of Kennebunk, of the county of York, of the State of Maine, and RUFUS H. HURLBUT, of Sudbury, of the county of Middlesex and State of Massachusetts, have invented a new and useful Improvement in Machinery for Forming or Shaping Boot or Shoe Counters; and do hereby declare the same to be described in the following specification and represented in the accompanying drawings, of which—

Figure 1 is a front elevation, Fig. 2 a vertical section, and Fig. 3 a side elevation, of a machine embodying our invention.

On June 26, 1877, Letters Patent No. 192,341, for a machine for forming boot and shoe counters, were granted on an invention made by one of the undersigned. In such machine the two rotary concave shapers or wipers, which were combined with a convex counter-former, had a common pivot or center, and were provided with gears to operate in stationary racks. The counter-former was circular in transverse section.

Our present machine, which is intended to overcome certain difficulties incident to the patented machine above mentioned, has a counter-former having a different form in its vertical transverse section, and the shapers or wipers to operate with such former do not have a common pivot, but they are supported by levers, or are projected from two slotted arms, which are pivoted to the shapers, and to two levers, provided with weights, suspended from their longer arms, all being as represented in the drawings, in which—

A is the counter-former, and B and C the two concave shapers or wipers; D D, the slotted arms; E E, the levers, and F F their weights.

The said levers, arranged as shown, and having separate fulcra *a a*, are hinged at their inner arms to the lower parts of the slotted arms.

Fig. 4 is a perspective view of one of the slotted arms and the wiper extending from it, the other wiper and its slotted arm being similarly constructed. The slot of the arm is shown at *b*. These arms, arranged with the counter-former A in manner as shown, have studs or pivots *c* extending from it into their slots.

The counter-former is attached to the lower end of a vertical bar, G, arranged in guides H H, projecting from a standard, I. In the upper part of the bar G is a horizontal slot, *d*, into which the wrist *e* of a crank, K, projects, such crank being fixed to a rotary shaft, L. On revolving such shaft vertical motions will be imparted to the counter-former A. While such counter-former is descending the wipers move apart and about it, and adjust themselves with respect to it, so as to spread and force closely against it a counter-blank when between it and them.

The pressure of the wipers on the blank may be increased or diminished, as may be desirable, by increasing or diminishing the weights on the levers. Extending under the longer arm of each lever is a stop, S, upon which the arm rests, in order to estop the wipers when close together, and just before the counter-former may have completed its upward movement, such being to enable a counter-blank to be inserted between the said former and the wipers preparatory to the next descent of the said former. As the former may be forced downward, it will press the blank against the wipers, which will be caused to move over it in a manner to bend and press it into close contact with the former.

We claim—

1. The combination of the levers E E and the slotted arms D D with the wipers B C and the reciprocating counter-former A, all being arranged and to operate substantially as set forth.

2. In combination with the counter-former A, the two wipers B C, arranged therewith and supported by weighted levers E E, having separate fulcra *a a*, and stops S S, disposed relatively to them and the said frame substantially as set forth.

GEORGE F. MOORE.  
RUFUS H. HURLBUT.

Witnesses to signature of George F. Moore:  
CHARLIE W. GOODNOW,  
GEO. W. WALLINGFORD.

Witnesses to signature of Rufus H. Hurlbut:  
BENJN. H. RICHARDSON,  
LEONARD F. RICHARDSON.