

Nov. 11, 1947.

H. H. NELSON

2,430,579

VENETIAN BLIND FILTER

Filed July 19, 1944

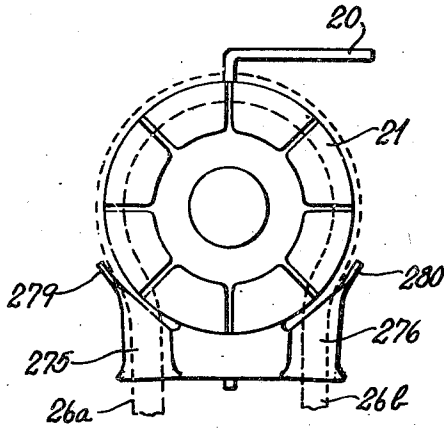

Fig. 1.

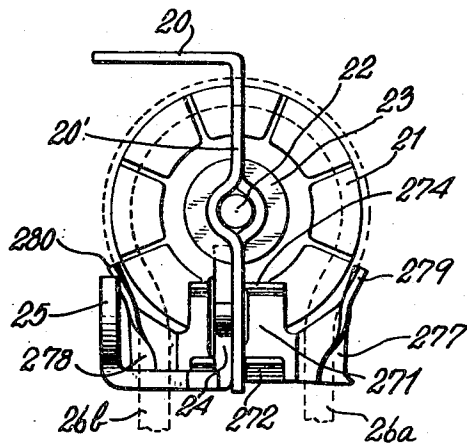

Fig. 2.

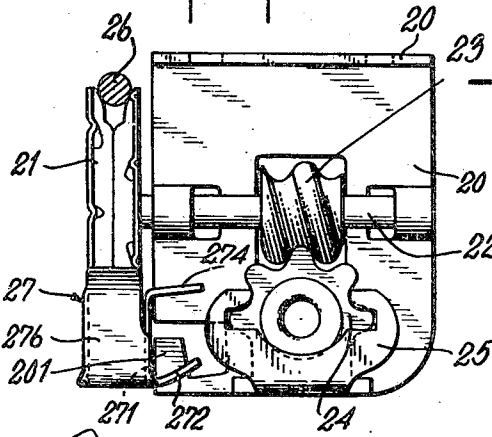

Fig. 3.

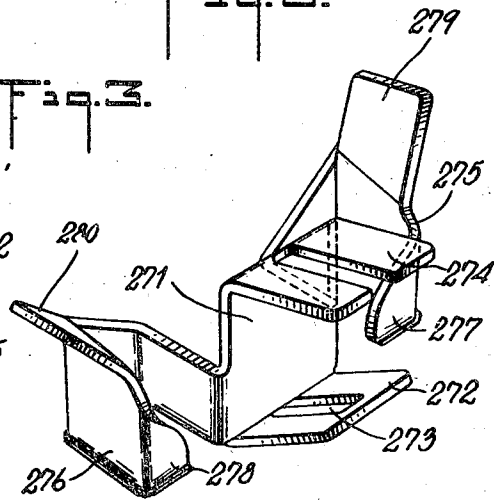

Fig. 4.

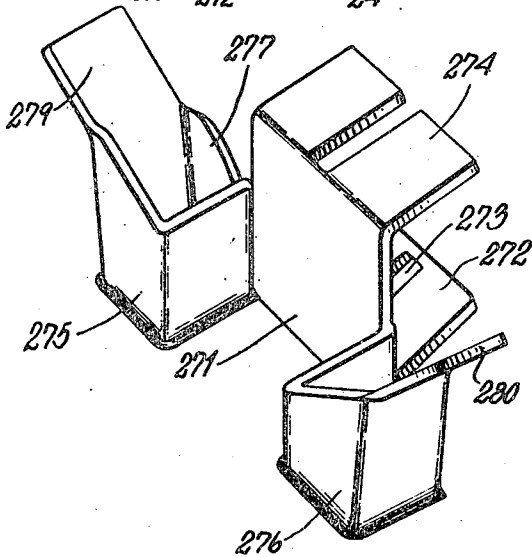

Fig. 5.

INVENTOR

Harry H. Nelson

BY

Ramsey, Kent & Childers
ATTORNEYS

UNITED STATES PATENT OFFICE

2,430,579

VENETIAN BLIND TILTER

Harry H. Nelson, New York, N. Y., assignor to
Lorentzen Hardware Mfg. Corp., New York,
N. Y., a corporation of New York

Application July 19, 1944, Serial No. 545,555

14 Claims. (Cl. 160—177)

1

My invention relates to improvements in Venetian blind tilters and has to do, more particularly, with the portion thereof known as the cord guide.

It is a primary object of my invention to provide a cord guide structure for Venetian blind tilters the mounting for which is of such character as to allow the guide some degree of in-and-out movement in conformity with wobble or other axial shifting of the tilter cord sheave. Such wobbling and shifting is often experienced in tilting mechanism for Venetian blinds as manufactured in large quantities by production methods.

It is also an object of my invention to provide a cord guide for Venetian blind tilters the guide channels of which have sufficient length to insure smooth running of the cord strings therein yet which are of such design as to enable close association with the cord sheave and eliminate the necessity for their extension so far below the cord sheave axis as to run the chance of abutment with, and marring of, the top slat of the blind structure associated therewith. Moreover, a cord guide designed in accordance with this phase of my invention is inherently free from tendency to bind against the surfaces of the cord sheave and operate as a friction brake thereon interfering with smooth and easy actuation of the tilter.

Other objects of my invention are to provide a cord guide for Venetian blind tilters which guide constrains the cord to reeve upon the cord sheave with high traction; which directs the cord strings to hang in closely-spaced vertical parallelism; and which otherwise maintains the cord in such association with the tilter mechanism as to militate against undesirable cord dissociation, friction, kinking, and wear.

Further objects, and objects relating to details and economies of construction and operation will more definitely appear from the detailed description to follow.

My invention is clearly defined in the appended claims. In the claims, as well as in the description, parts are identified by specific names for convenience, but such nomenclature is intended to be as generic, in its application to similar parts, as the prior art will permit. The best form in which I have contemplated applying my invention is illustrated in the accompanying drawing forming part of this specification, in which:

Fig. 1 is a view, in front elevation, of a tilter and cord guide embodying my invention;

2

Fig. 2 is a view, in rear elevation, of the tilter and guide structure shown in Fig. 1;

Fig. 3 is a view, in side elevation, of the same tilter and guide structure;

Fig. 4 is a perspective view of the cord guide element per se, the view being drawn to an enlarged scale; and

Fig. 5 is a perspective view of the cord guide element taken from another angle revealing the rear portions thereof, the view being drawn to an enlarged scale.

The same reference characters refer to the same parts throughout the several views.

In common practice, the mechanism employed for tilting the slats of a Venetian blind comprises a rocker having a gear sector, a worm shaft journaled in an L-shaped sheet-metal bracket, one plate portion of which is horizontally secured to the head bar of the blind and the other, shaft-receiving, plate portion of which depends therefrom in a plane transverse the mean plane of the blind, a pulley or sheave integrally carried by the shaft, a tilter cord reeved over the pulley, and a guide member for retaining the cord in association with the pulley. The pulley is usually formed from sheet metal and its inexpensive construction, as well as the simple form of the bearings provided for the worm shaft, do not insure precision running of the pulley groove in a fixed plane. Accordingly, the cord guide is desirably capable of some degree of movement in conformity with cord shifts induced by the grooved pulley or sheave in its rotation.

In a broad sense, my invention may be said to consist in the provision of such a cord guide in the form of a central plate portion for transverse abutment with the front edge of the depending portion of the aforementioned shaft-bearing bracket, a rearwardly extending flange at the base of said plate portion provided with a slot-like perforation to be hung upon a hook formed in the lower front corner of the bracket, a slotted flange at the top of said plate portion for straddling the bracket above its said hook formation, and wings along each side of the plate portion formed into channels which constrain the free ends of strings or the reeved cord to positions of substantially vertical tangency with respect to the base of the sheave groove. Preferably the cord guide is formed from a single sheet of metal and the channels thereof open rearwardly to preclude disengagement of the cord from the sheave except by displacing the cord strings in a rearward direction.

Referring, now, to the accompanying drawing, the tilter mechanism proper is generally similar to that disclosed in my U. S. Patent No. 2,298,891 granted October 13, 1942, and consists, essentially of a rocker 25 having a gear sector 24, a worm 23, a worm shaft 22 journaled in an L-shaped sheet metal bracket 20 provided with a horizontal plate portion to be secured to the head bar (not shown) of the blind and a depending shaft-bearing plate portion 20' which lies in a plane transverse the mean plane of the blind, a pulley or cord sheave 21 substantially integral with the front end of the worm shaft 22, a tilter cord 26 draped over the sheave, and a guide member 27 for retaining the cord in proper association with the cord sheave.

The present invention relates to improvements in guide members for such tilter mechanisms generally, and finds embodiment, in the preferred form of my invention herein specifically illustrated, as a simple pressed member formed of sheet metal and comprising a central plate portion 271 held in transverse abutment with the front edge of the bracket portion 20' by a lower flange 272 provided with a slot-like perforation 273 formed to be hung upon a hook 201 defined by cutting an L-shaped notch in the lower front corner of the bracket portion 20'. Another flange, 274, is provided at the top edge of the central plate portion 271 and this flange 274 is notched so as to straddle the bracket portion 20' above the hook 201 formed therein.

At the sides of the central plate portion 271 are provided cord-guiding channels 275, 276 which lie in a mean plane forward of the plane of the central plate portion 201; which are open at their rear faces for reception of the cord strings; and which are provided with cord-retentive tongues 277, 278, respectively. The outside walls of the channels 275 and 276 terminate, at their top edges, in outwardly flaring portions 279, 280, respectively, which assume an almost tangential relationship with respect to the periphery of the sheave 21. In addition, it will be noted that, adjacent these flaring portions or wings 279, 280, the side walls proper of the channels 275, 276 have, themselves, a slight flare, for a purpose to be explained.

From the foregoing description of the shape and character of the illustrated cord guide, its mode of installation and use, as well as the advantages inherent thereto, should be readily understood. The cord guide 27 is preferably assembled with the bracket portion 20' before the shaft 22 and sheave 21 are installed. Such assembly is accomplished by bringing the plate portion 271 into abutment with the front edge of the bracket portion 20' while holding the plate portion at an elevated position such that the flange 272 may enter the mouth of the L-shaped slot which defines the hook 201. After the notched upper flange 274 is astride the bracket portion 20' and the plate portion 271 is in abutment therewith, descent of the cord guide 27 will effect hooked engagement of the slot-like perforation 273 of the lower, slightly upwardly curved flange 272 with the hook formation 201. The slot 273 is slightly longer than the corresponding portion of the hook 201, with the result that a slight hinging of the lower flange 272 on its impaling hook 201 is permitted, which hinging is limited, inwardly, by the abutment of the plate portion 271 on the edge of the bracket portion 20', and, outwardly, by the upwardly turned extremity of the flange 272. Lateral play between the guide and bracket 20 is,

however, substantially precluded by the straddle character of the association.

With the assembly of cord guide and bracket 20 completed as above described, the worm 23 may be inserted in mesh with the sector gear 24, and the shaft 22 and sheave 21 then installed. The tilter cord 26 may thereafter be reeved upon the sheave 21 with its strings 26a and 26b extended through the channels 275, 276, respectively, of the guide. Disposition of the cord strings in these guide channels is accomplished by insertion thereof from the rear past the tongues 277, 278, respectively. It will be seen, particularly by reference to Fig. 2 of the drawing, that the configuration of the tongues 277 and 278, as well as the slightly greater spacing of the flanges 279, 280 of the guide at the rear than at the front edge of the sheave 21 periphery, contribute to facilitate insertion of the cord strings 26a, 26b into the guide channels 275, 276. Preferably, the spaces through which the cord strings are to be thus inserted are of such width, relative to the cord thickness, that the insertion is in the nature of a "snapping" of the cord therepast. Thus, only an intentional act would suffice to retract the cord strings from the channels 275, 276 once they be inserted therein. Normally, too, the presence of the slats of the blind in close proximity to the rear of the guide and cord strings normally depending therefrom militate to prevent any rearward displacement of the cord strings tending to release the cord from the retentive effect of the tongues 279, 280 of the cord guide.

That the objects of my invention, as outlined at the introductory portion of this specification, are realized in a structure of the type herein described as a preferred embodiment of my invention, should be manifest. Any wobble or other shifting of the sheave 21 due to slight injury or imperfections in manufacture and assembly, or to excessive play in the shaft 22, will be automatically taken care of by the limited in-and-out hinging allowed the guide member by the hook 201 upon which it is impaled. The straddle character of the mounting upon the bracket portion 20' is such that substantially no lateral or rotative movement is permitted the cord guide. Thus, no rubbing of the guide upon any portion of the sheave 21 is possible after the blind is hung. Because of the extremely slight amount (less than 1/2 of an inch in the device depicted) which the guide extends below the axis of the gear 24, the top slat of the conventional blind assembly (not shown) intended for use therewith cannot be marred thereby, either in use or during packaged shipment preliminary to installation.

The structure herein claimed is one wherein a minimum of rubbing, kinking or other abuse of the cord may be expected and it is also one which is susceptible of manufacture at low cost, by simple equipment, of inexpensive material, and with a minimum of expense for the labor of assembly.

I am aware that some features of my invention may be embodied in forms other than those herein illustrated and described, and I therefore claim my invention broadly, as well as specifically, as indicated by the appended claims. It is to be understood that the terms employed in each claim are to be given their broadest meaning consistent with their application to the concepts of my invention as distinguished from the prior art pertinent thereto.

Wherever, in this specification and the appended claims, reference is made to a "cord" for

5

operating the sheave or other drive wheel of the mechanism, it is to be understood that this term comprehends any such flexible member, whether said member be formed of metal, such as a link or bead chain, or be formed of non-metallic material, such as leather, gut, plastic or textile fabric.

What I claim is:

1. A Venetian blind tilter comprising: a bracket, a cord wheel supported by said bracket for rotation by a tilter-operating cord reeved thereover, and a cord guide for directing the pendant strings of said cord, said cord guide having a lower portion hung on said bracket at a position below said wheel to enable the wheel-adjacent portion of the cord guide to swing in conformity with displacements of the cord due to wheel wobble or play and having stop means for limiting the extent of hinged swing to an amount corresponding to the maximum wobble and play anticipated in the wheel.

2. A Venetian blind tilter comprising: a bracket provided with a hook, a cord wheel supported by said bracket and journaled above said hook for rotation by a tilter-operating cord reeved thereover, and a cord guide for directing the pendant strings of said cord, said cord guide having a portion impaled upon said bracket hook for supporting said guide while enabling the wheel-adjacent portion of the cord guide to swing in conformity with displacements of the cord due to wheel wobble or play and having another portion spaced from said hook-impaled portion and engageable with said bracket to limit the extent of said swing.

3. A Venetian blind tilter comprising: a bracket formed adjacent its lower end with a hook, a cord wheel supported by said bracket and journaled for rotation by a tilter-operating cord reeved thereover, the wheel being located at a higher level than the hook and being disposed in a plane transverse the plane of the hook-formed portion of said bracket, and a cord guide for directing the pendant strings of said cord, said cord guide having a perforate flange swingably impaled upon said bracket hook enabling the wheel-adjacent portion of the cord guide to swing in conformity with the displacements of the cord due to wheel wobble or play and having a slotted flange astride said bracket above said hook for guiding and limiting the extent of hinging of said cord guide relative to said bracket.

4. A Venetian blind tilter comprising: a bracket having a plate portion arranged in a vertical plane transverse the mean plane of the blind, said plate portion having an L-shaped notch therein defining a hook, a cord wheel journaled for rotation by a tilter-operating cord reeved thereover, the wheel being located at a higher level than the hook and being disposed in a plane transverse the plane of said bracket, and a cord guide for directing the pendant strings of said cord, said cord guide having a pair of substantially horizontal flanges the lower one of which is formed with a perforation generally complementary to the bracket hook and through which said hook extends, and the upper flange of which is slotted and straddles said plate portion at a position above the L-shaped notch therein.

5. In a Venetian blind tilter, a cord-driven wheel, a cord guide for directing the pendant strings of a cord reeved on said wheel, and a structure supporting the wheel and cord guide, the cord guide being positioned closely beneath the cord-driven wheel and comprising a vertical

6

plate member attached to the supporting structure, said plate member having its side edges laterally extended in the form of individual non-communicating downwardly-directed vertical barrels, one at each side of the cord-driven wheel in substantially tangential relation to the portion of the wheel periphery adjacent to the upper extremity thereof.

6. In a Venetian blind tilter, a cord-driven wheel, a cord guide for directing the pendant strings of a cord reeved on said wheel, and a structure supporting the wheel and cord guide, the cord guide being positioned closely beneath the cord-driven wheel and comprising a vertical plate member attached to the supporting structure, said plate member having its side edges laterally extended in the form of individual non-communicating downwardly-directed vertical barrels with flaring upper extremities at each side of the cord-driven wheel, the outside wall of each of said barrels lying substantially tangent to the traction surface of said wheel and the flared extremities of said barrels lying substantially tangent to the outer arc of the cord portion normally reeved upon said wheel.

7. In a Venetian blind tilter, a cord-driven wheel, a cord guide for directing the pendant strings of a cord reeved on said wheel, and a structure supporting the wheel and cord guide, the cord guide being positioned closely beneath the cord-driven wheel and comprising a vertical plate member attached to the supporting structure, said plate member having its side edges laterally extended in the form of rearwardly-open individual non-communicating box-like downwardly-directed vertical barrels the outside wall of each of which lies approximately tangent to the traction surface of the wheel at diametrically-opposite sides thereof and the upper extremities of the outside walls of which barrels are respectively outwardly and upwardly extended and lie approximately tangent to the outer arc of the cord portion normally reeved upon said wheel.

8. A Venetian blind tilter comprising: a bracket having a plate portion arranged in a generally vertical plane transverse the mean plane of the blind, said plate portion having an L-shaped notch therein defining an upstanding hook at its lower forward corner, a cord wheel supported by said bracket and journaled for rotation by a tilter-operating cord reeved thereover, the wheel being located at a higher level than the hook and being disposed in a plane transverse the plane of said bracket plate portion, and a cord guide comprising a generally rectangular plate member having rearwardly-extending top and bottom flanges, the bottom flange of which is upwardly directed and is provided with a perforation through which said bracket hook extends, the top flange of which is slotted and lies astride the bracket plate portion above the hook thereof, and the side flanges of which have the form of barrels of generally rectangular cross-section with flaring top edges and which receive the respective pendant strings of said cord and constrain each of said strings to a position of approximate tangency with respect to the traction surface of said wheel.

9. A Venetian blind tilter comprising: a bracket having a plate portion arranged in a generally vertical plane transverse the mean plane of the blind, said plate portion having an L-shaped notch therein defining an upstanding hook at its lower forward corner, a cord wheel supported by

said bracket and journaled for rotation by a tilter-operating cord reeved thereover, the wheel being located at a higher level than the hook and being disposed in a plane transverse the plane of said bracket plate portion, and a cord guide comprising a generally rectangular plate member having rearwardly-extending top and bottom flanges, the bottom flange of which is upwardly directed and is provided with a perforation through which said bracket hook extends, the top flange of which is slotted and lies astride the bracket plate portion above the hook thereof, and the side flanges of which have the form of barrels slotted along their rear faces to enable forced insertion of the respective pendant strings of said cord and which constrain each of said strings to a running position of approximate tangency with respect to the traction surface of said wheel.

10. A Venetian blind tilter comprising: a bracket having a plate portion arranged in a generally vertical plane transverse the mean plane of the blind, said plate portion having an L-shaped notch therein defining an upstanding hook at its lower forward corner, a cord wheel supported by said bracket and journaled for rotation by a tilter-operating cord reeved thereover, the wheel being located at a higher level than the hook and being disposed in a plane transverse the plane of said bracket plate portion, and a cord guide comprising a generally rectangular plate member having rearwardly-extending top and bottom flanges, the bottom flange of which is upwardly directed and is provided with a perforation through which said bracket hook extends, the top flange of which is slotted and lies astride the bracket plate portion above the hook thereof, and the side flanges of which have the form of barrels of generally rectangular cross-sectional configuration with flaring top edges and slotted rear faces to enable forced insertion of the respective pendant strings of said cord and which constrain each of said strings to a running position of approximate tangency with respect to the traction surface of said wheel.

11. A Venetian blind tilter comprising: a bracket having a plate portion arranged in a generally vertical plane transverse the mean plane of the blind, said plate portion having an L-shaped notch therein defining an upstanding hook at its lower forward corner, a cord sheave supported by said bracket forward of and above said hook and journaled for rotation by a tilter-operating cord reeved thereover, the wheel being disposed in a plane transverse the plane of said bracket plate portion, and a cord guide comprising a generally rectangular plate member having rearwardly extending top and bottom flanges and forwardly-extending side flanges, the bottom flange of which is upwardly directed and is provided with an elongate perforation receptive of said bracket hook with some degree of in-and-

out rocking movement, the top flange of which is slotted and straddles the bracket portion above the hook thereof enabling transverse abutment of the plate member with the front edge of said bracket, and the side flanges of which have the form of barrels with flared top edges and slotted rear walls having a slight resiliency enabling forced insertion therein of the respective pendant strings of said cord.

12. A guide member for directing the pendant strings of a Venetian blind tilter having a cord-driven wheel, comprising: a plate member provided with means for supporting same closely beneath the cord-driven wheel of the tilter, and having its side edges laterally extended in the form of individual non-communicating downwardly-directed barrels, one at each side of the cord-driven wheel in substantially tangential relation to the portion of the wheel periphery adjacent to the upper extremity thereof.

13. A guide member for directing the pendant strings of a Venetian blind tilter having a cord-driven wheel, comprising: a plate member provided with means for supporting same closely beneath the cord-driven wheel of the tilter, and having its side edges laterally-extended in the form of individual non-communicating downwardly-directed barrels with flaring upper extremities at each side of the cord-driven wheel, the outside wall of each of said barrels lying substantially tangent to the traction surface of said wheel and the flared extremities of said barrels lying substantially tangent to the outer arc of the cord portion normally reeved upon said wheel.

14. A guide member for directing the pendant strings of a cord-operated Venetian blind tilter, comprising: a plate member provided with means for supporting same closely beneath the cord-driven wheel of the tilter and having its side edges laterally extended in the form of rearwardly-open individual non-communicating box-like downwardly directed barrels the outside wall of each of which lies approximately tangent to the traction surface of the wheel at diametrically-opposite sides thereof and the upper extremities of the outside walls of which barrels are respectively outwardly and upwardly extended and lie approximately tangent to the outer arc of the cord portion normally reeved upon said wheel.

HARRY H. NELSON.

REFERENCES CITED

55 The following references are of record in the file of this patent:

UNITED STATES PATENTS

Number	Name	Date
60 2,239,621	Nisenson	Apr. 22, 1941
2,298,891	Lorentzen	Oct. 13, 1942