

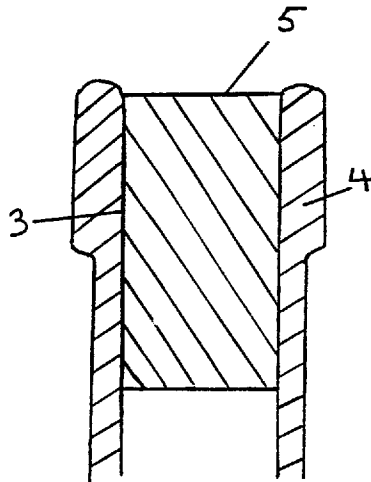

- (72) TAYLOR, David Graham, GB  
(72) BEANLAND, David, GB  
(71) Betacorque Limited, GB  
(51) Int.Cl.<sup>6</sup> B65D 39/00, B29C 51/10, B29C 44/56  
(30) 1995/05/03 (9508972.8) GB  
(30) 1996/01/10 (9607815.9) GB  
(54) **DISPOSITIF DE FERMETURE POUR RECIPIENTS**  
(54) **CLOSURE DEVICE FOR CONTAINERS**



(57) Dispositif de fermeture d'un récipient, comme une bouteille de vin. Ce dispositif est constitué d'un corps (1) de section circulaire, de préférence cylindrique, qui est conçu pour s'ajuster dans une ouverture du récipient afin de le fermer. Ce corps comprend essentiellement une mousse moulée de polymère de copolymère à alvéoles fermés, de préférence du polystyrène expansé, ayant une densité sensiblement uniforme d'au moins 0,03 g/cc. Le dispositif de fermeture peut être partiellement ou entièrement recouvert d'une substance d'étanchéité (5). Il peut être ciré, coloré et/ou traité, afin de lui donner encore plus l'apparence du liège, et il peut aussi être imprimé.

(57) A closure device for a container such as a wine bottle comprising a body (1) of circular cross section, preferably cylindrical, which is adapted to fit in an opening in the container to seal said container said body consisting essentially of a moulded foamed closed-cell polymer of copolymer, preferably expanded polystyrene, having a substantially uniform density of at least 0.03 g/cc. The closure device may be partially or wholly coated with a sealing material (5), waxed, coloured and/or surface-treated to render it even closer in appearance to cork, and printed on.

**PCT**WORLD INTELLECTUAL PROPERTY ORGANIZATION  
International Bureau

## INTERNATIONAL APPLICATION PUBLISHED UNDER THE PATENT COOPERATION TREATY (PCT)

(51) International Patent Classification <sup>6</sup> : <b>B65D 39/00</b>	<b>A1</b>	(11) International Publication Number: <b>WO 96/34806</b> (43) International Publication Date: 7 November 1996 (07.11.96)
<p>(21) International Application Number: PCT/GB96/01065</p> <p>(22) International Filing Date: 3 May 1996 (03.05.96)</p> <p>(30) Priority Data: 9508972.8 3 May 1995 (03.05.95) GB 9607815.9 10 January 1996 (10.01.96) GB</p> <p>(71)(72) Applicants and Inventors: TAYLOR, David, Graham [GB/GB]; 37 Linersh Wood Road, Bramley, Guildford, Surrey GU5 0EE (GB). BEANLAND, David [GB/GB]; 2 Halfway Cottages, Dippenhall, Farnham GU10 5DR (GB).</p> <p>(74) Agent: BAVERSTOCK, Michael, George, Douglas; Boulton Wade Tennant, 27 Farnival Street, London EC4A 1PQ (GB).</p>	<p>(81) Designated States: AL, AM, AT, AU, AZ, BB, BG, BR, BY, CA, CH, CN, CZ, DE, DK, EE, ES, FI, GB, GE, HU, IS, JP, KE, KG, KP, KR, KZ, LK, LR, LS, LT, LU, LV, MD, MG, MK, MN, MW, MX, NO, NZ, PL, PT, RO, RU, SD, SE, SG, SI, SK, TJ, TM, TR, TT, UA, UG, US, UZ, VN, ARIPO patent (KE, LS, MW, SD, SZ, UG), Eurasian patent (AM, AZ, BY, KG, KZ, MD, RU, TJ, TM), European patent (AT, BE, CH, DE, DK, ES, FI, FR, GB, GR, IE, IT, LU, MC, NL, PT, SE), OAPI patent (BF, BJ, CF, CG, CI, CM, GA, GN, ML, MR, NE, SN, TD, TG).</p> <p><b>Published</b> <i>With international search report.</i> <i>With amended claims and statement.</i></p> <p>Date of publication of the amended claims and statement: 5 December 1996 (05.12.96)</p>	

(54) Title: CLOSURE DEVICE FOR CONTAINERS

## (57) Abstract

A closure device for a container such as a wine bottle comprising a body (1) of circular cross section, preferably cylindrical, which is adapted to fit in an opening in the container to seal said container said body consisting essentially of a moulded foamed closed-cell polymer of copolymer, preferably expanded polystyrene, having a substantially uniform density of at least 0.03 g/cc. The closure device may be partially or wholly coated with a sealing material (5), waxed, coloured and/or surface-treated to render it even closer in appearance to cork, and printed on.

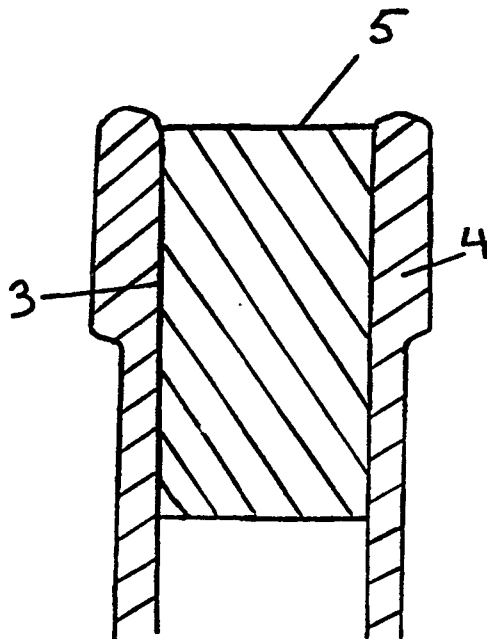

- 1 -

CLOSURE DEVICE FOR CONTAINERS

This invention relates to a closure device for containers.

5 Closure devices for containers are commonly made of natural materials such as cork. These are used for temporarily sealing containers in order to prevent spillage and to preserve the contents of the container. They have a traditional appeal and are effective. Very large quantities are used in wine 10 bottling and they are also used for other foodstuffs and for other substances such as cosmetics. However, they have the disadvantage of being relatively expensive, are labour intensive to produce, are subject to quality variations and can introduce 15 microorganisms and other impurities to the stored substance. These disadvantages have been recognised for some time and synthetic substitutes have been developed using synthetic rubbers and plastics. 20 These, however, have the disadvantages of being more expensive than natural materials, of not being readily reusable, of not looking and feeling like natural materials and of behaving differently to the natural materials. Consumers notice these differences and are 25 put off, thus reducing the acceptability of these substitutes in the marketplace. There is thus a need for a synthetic closure which looks, feels and behaves similarly to the natural material but with advantages of low cost, consistent quality, and of being sterile.

30 In EP-A-0 496 194 there is described and claimed a sealing closure for containers of liquids characterised in that it comprises a substantially cylindrical plastic element, which may be made of foamed polystyrene, in which an also substantially 35 cylindrical elastic insert, which may be of cork, is

- 2 -

axially embedded. However, such a design of closure appears potentially to have serious drawbacks from the point of view of lack of sterility due to the presence of the natural cork; from the point of view of structural integrity; and from the point of view of inadequate elastic behaviour. Also, although it is stated in the description of the patent specification that the production cost will be low, the complex structure of the product would indicate the contrary.

5  
10 There is therefore still a demand for a satisfactory alternative to cork closures for containers, and particularly for liquid containers such as wine bottles.

15 According to the present invention there is provided a closure device for a container comprising a body of circular cross-section which is preferably cylindrical and which is adapted to fit in an opening in the container to seal said container said body consisting essentially of moulded foamed closed-cell polymer or copolymer preferably expanded polystyrene, having a substantially uniform density of at least 0.03 g/cc.

20  
25 It should be noted that the closure device of the invention does not contain an insert of any other material in its body.

The particularly preferred polymeric material of the closure device of this invention is expanded polystyrene. Expanded polystyrene is well known for its very low density and it is extensively employed, for example, in packaging applications in which the expanded polystyrene used may typically have a density of 0.016 g/cc. It is important to note, however, that an essential novel feature of the present invention is that the polymeric material used has a density of at least 0.03 g/cc so that it is more comparable in

30  
35

- 3 -

density to cork which typically has a density of around 0.1 g/cc although varying depending its source. Also the increased density of the material renders it more impermeable to gases and liquids. Thus, the process conditions used for the production of moulded expanded polystyrene closure devices of the present invention are controlled, in known conventional manner, to produce a final density of at least 0.03 g/cc.

Although the preferred shape of the body of closure device in accord with the invention is substantially cylindrical it may for example be of other shapes having a circular cross-section, for example frustoconical. Also, the closure device may have an enlarged end, that is an end which has a larger diameter than the body of the closure device, similar to that of the types of cork which are used for sealing wines of the "Champagne" type in which the enlarged end serves to provide an anchorage for a wire fastening attached to the neck of the bottle to secure the closure device against being forced out of the mouth of the bottle by the internal pressure of the gas in the bottle.

The closure device of the invention is inserted into the opening of a container to prevent the material held in the container escaping through the container's opening when the closure is in place. It also prevents outside contaminants such as gases, moisture, bacteria or fungi from entering the container through the opening. Through achieving an air-tight seal, it maintains the material stored in the container in as near perfect a condition as possible.

The polymeric material of the closure is desirably coloured to look like the natural material

- 4 -

that it replaces and is also desirably surface-textured or otherwise physically surface-treated with the same end in view. It can also be painted and/or be printed with information on its surface if  
5 required.

The closure may be pressure treated in its manufacture for example by rolling. It was originally thought that this pressure treatment increased both the elasticity and the density of only a surface layer  
10 of the material. However it is now believed that the pressure treatment increases the elasticity and density of the whole body of the closure but that there is no significant resulting change in the uniformity of its density. This pressure treatment  
15 enhances the closure's ability to press against the walls of the container opening and thereby to seal it.

The closure may also be coated with a flexible impervious coating such as polyurethane if an additional degree of impermeability is required. The  
20 closure may also be waxed. Additionally, any coating composition used may contain colour so as to render the closure device of similar colour to that of natural cork.

A specific embodiment of the invention will now be described by way of example with reference to the  
25 accompanying drawing in which:

Figure 1 shows a perspective of the closure device, in this case acting as a substitute for a cork in a wine bottle.  
30

Figure 2 shows the closure device in place in a wine bottle.

Referring to the drawings, the closure device comprises a cylinder of expanded polystyrene 1 of substantially uniform density greater than 0.03 g/cc.  
35 At such higher densities, the expanded polystyrene

- 5 -

exhibits a greatly reduced permeability to gases and water vapour, and to other fluids. Expanded polystyrene is resistant to alcohol and is an approved material for contact with foodstuffs. It is

5 biologically inert and acts as a barrier to the ingress of bacteria and moulds. Also, as mentioned above, at higher densities such as above 0.03 g/cc it also compares favourably to cork in density and also

10 has a microstructure of similar appearance to that of cork. The texture of its external surface 2 is already very cork-like and this is desirably enhanced by colouring and/or by physically treating the surface, for example by shaving, sanding or texturing. The frictional properties between high density

15 expanded polystyrene and glass compare favourably to those between cork and glass. It should be noted however that cork relies to some extent on absorption of liquid from the contents of the container in order to achieve its effectiveness in sealing whereas the

20 closure device of the present invention does not absorb liquids to any significant degree.

As is well known in the art, expanded polystyrene is conventionally produced by a bead process using a suspension polymerisation technique. A blowing agent

25 such as for example about 6% of a low boiling petroleum ether fraction, e.g. n-pentane, is either incorporated before polymerisation, or after polymerisation the beads are impregnated under heat and pressure. The beads are then processed by steam

30 moulding. The beads are first pre-foamed by heating in a steam bath. This causes the beads to expand and the expansion is continued until they reach an appropriate level in the mould corresponding to the desired density. This may be determined by a suitably

35 positioned thermocouple which is arranged to cause the

- 6 -

steam to be switched off when this point is reached. The expanded beads are then allowed to stand for 24 hours to allow them to cool to room temperature and to allow air to diffuse into the cells so that the cells  
5 equilibrate with outside conditions.

Then a steam moulding process is performed. The beads are charged into a mould which is provided with perforated walls to admit steam. The mould is completely filled with the beads. Steam is then  
10 passed into the mould causing the beads to swell further and to weld with each other and take up the shape of the mould.

When the bodies of the closure devices are to be substantially cylindrical the mould itself may be in  
15 the form of a plurality of cylinders which may be interlinked each of which cylinders may be several times the length of the closure devices to be produced.

When moulding is complete the mouldings are taken  
20 out of the moulds, trimmed, cut to length, printed, textured, coated and waxed with paraffin wax, as appropriate.

It should be understood of course that the above-mentioned specific procedure can be varied in many  
25 respects without departing from the scope of the invention as hereinafter claimed.

The resulting closure devices can be inserted directly into a container such as a bottle at this stage if the mouldings are of sufficiently small  
30 diameter. However, for greater pull strengths larger diameter mouldings are used which are reduced in size by compression, e.g. by rolling, before being put into a conventional cork inserter.

It should be mentioned that because expanded  
35 polystyrene does not have the same elasticity as cork

- 7 -

it is usually necessary to adjust conventional cork  
inserters from a usual diameter of 16 mm for a  
conventional cork closure to a diameter of say 18 mm  
for the closure device of the present invention, to  
5 allow for this difference in elasticity and  
corresponding expansion.

As mentioned above, the closure device may be  
pressure treated, for example by rolling, to improve  
the elasticity of the polystyrene. The closure device  
10 is compressed as it is pushed into a bottle 3 and  
provides a seal against the glass. On withdrawal the  
elasticity of the closure device creates a good  
simulation of the sensation of a real cork being  
removed from a bottle and allows the closure device to  
15 be reinserted if required. The closure device retains  
rigidity thus providing mechanical strength to prevent  
the closure device from distorting through bending  
when it is pushed into a bottle 4 and to provide  
purchase for extraction devices. The high density  
20 expanded polystyrene is practically impervious to  
gases and fluid of the nature likely to be encountered  
in wine. Additional protection can be given by  
treating the ends and/or sides with a colourless  
impermeable coating such as polyurethane 5.

25 As explained above, therefore, the closure device  
of the invention thus consists essentially solely of  
an expanded closed-cell polymer, preferably expanded  
polystyrene, which has a substantially constant  
density of greater than 0.03 g/cc throughout, and  
30 which can be partially or wholly surface coated with  
an impermeable sealing material for example with  
polyurethane and/or a wax to prevent moisture and  
gaseous movement through and around the closure  
device.

35

CLAIMS:

1. A closure device for a container comprising a body of circular cross-section which is adapted to fit in an opening in the container to seal said container said body consisting essentially of a moulded foamed closed-cell polymer which is expanded polystyrene having a substantially uniform density of at least 0.03 g/cc.
2. A closure device as claimed in claim 1 wherein said body is substantially cylindrical.
3. A closure device as claimed in claim 1 or claim 2 wherein the expanded polystyrene is coloured so as to render the closure device of similar colour to that of natural cork.
4. A closure device as claimed in claim 1 or claim 2 having a surface which is partially or wholly coated with a sealing material, for example a polyurethane resin and/or with wax, which may contain colour so as to render the closure device of similar colour to that of natural cork.
5. A closure device as claimed in any one of the preceding claims whose surface has been physically treated, for example by shaving, sanding or texturing, to bring its appearance closer to that of natural cork.
6. A closure device as claimed in any one of the preceding claims which is painted and/or has printed matter on its surface.

- 9 -

7. A closure device as claimed in any one of the preceding claims which is for use in wine bottles.

5 8. A method of making a closure device for a container which method comprises steam moulding expanded polystyrene beads in one or more cylindrical moulds having a diameter substantially corresponding to the diameter of the closure devices to be produced, the steam moulding process being performed under  
10 conditions such that a density of at least 0.03 g/cc is uniformly produced in the mouldings, the mouldings being thereafter removed from the moulds and then, if necessary, the mouldings are trimmed and cut to the desired length of the closure device, and, if desired,  
15 the mouldings are partially or wholly coated with a sealing material, for example a polyurethane resin, and/or with wax either before or after the optional cutting to size.

20 9. A method as claimed in claim 9 wherein the mouldings are subjected to compression by rolling under pressure in order to reduce their diameter.

25 10. A container, either empty or when containing a liquid or a solid, whenever comprising a closure device as claimed in any one of claims 1 to 7 or when made by the method claimed in claim 8 or claim 9.

30

35

Fig 1

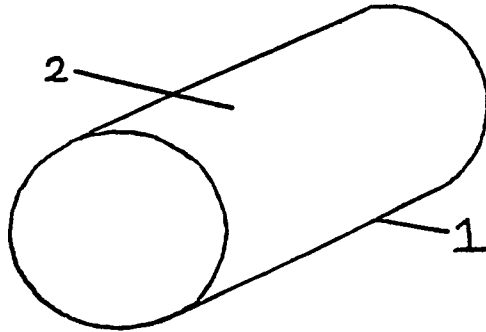

Fig 2

