



US009271405B2

(12) **United States Patent**
Takahashi et al.

(10) **Patent No.:** **US 9,271,405 B2**
(45) **Date of Patent:** ***Feb. 23, 2016**

(54) **FLEX-RIGID WIRING BOARD AND METHOD OF MANUFACTURING THE SAME**

(2013.01); *H05K 2201/09127* (2013.01); *H05K 2201/09509* (2013.01); *Y10T 29/4913* (2015.01);

(75) Inventors: **Michimasa Takahashi**, Ogaki (JP);
Masakazu Aoyama, Ogaki (JP)

(Continued)

(73) Assignee: **IBIDEN CO., LTD.**, Ogaki-shi (JP)

(58) **Field of Classification Search**

CPC *H05K 3/4691*
USPC 29/852, 830, 831, 832, 846, 847;
174/254, 264; 361/749; 156/150
See application file for complete search history.

(*) Notice: Subject to any disclaimer, the term of this patent is extended or adjusted under 35 U.S.C. 154(b) by 0 days.

This patent is subject to a terminal disclaimer.

(56) **References Cited**

U.S. PATENT DOCUMENTS

(21) Appl. No.: **13/562,895**

3,471,348 A * 10/1969 Iles *H05K 3/4691*
174/255

(22) Filed: **Jul. 31, 2012**

4,099,038 A * 7/1978 Purdy 200/61.08

(Continued)

(65) **Prior Publication Data**

US 2012/0291276 A1 Nov. 22, 2012

FOREIGN PATENT DOCUMENTS

CN 1806474 A 7/2006
DE 42 08 610 C1 5/1993

(Continued)

Related U.S. Application Data

(60) Continuation of application No. 12/574,309, filed on Oct. 6, 2009, which is a division of application No. 11/927,144, filed on Oct. 29, 2007, now Pat. No. 7,982,135.

Primary Examiner — Peter DungBa Vo
Assistant Examiner — Kaying Kue

(60) Provisional application No. 60/863,396, filed on Oct. 30, 2006.

(74) *Attorney, Agent, or Firm* — Oblon, McClelland, Maier & Neustadt, L.L.P.

(51) **Int. Cl.**

H05K 3/46 (2006.01)

H05K 3/36 (2006.01)

(Continued)

(57) **ABSTRACT**

A method of manufacturing a flex-rigid wiring board includes positioning a flexible board and a non-flexible substrate adjacent to each other, forming a metal layer over the flexible board such that the metal layer is formed to stop laser irradiation from reaching into the flexible board, forming an insulating layer such that the insulating layer covers the metal layer, the flexible board and the non-flexible substrate, irradiating laser upon the insulating layer such that a portion of the insulating layer covering the metal layer is cut; and removing the portion of the insulating layer covering the metal layer from the flexible board such that at least a portion of the flexible board is exposed.

(52) **U.S. Cl.**

CPC *H05K 3/4691* (2013.01); *H05K 1/0218* (2013.01); *H05K 3/0035* (2013.01); *H05K 3/4069* (2013.01); *H05K 3/4602* (2013.01); *H05K 3/4652* (2013.01); *H05K 3/4664* (2013.01); *H05K 2201/0187* (2013.01); *H05K 2201/0715* (2013.01); *H05K 2201/096*

20 Claims, 32 Drawing Sheets

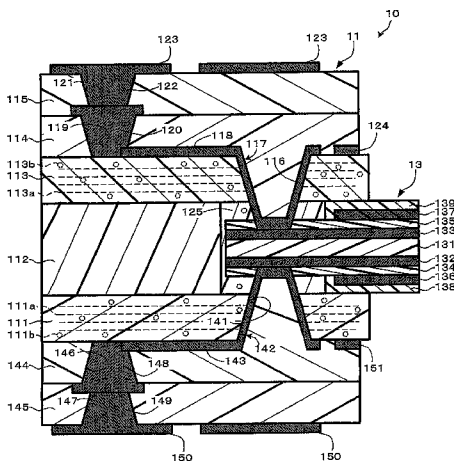

- (51) **Int. Cl.**
H05K 1/02 (2006.01)
H05K 3/00 (2006.01)
H05K 3/40 (2006.01)
- (52) **U.S. Cl.**
 CPC *Y10T 29/49124* (2015.01); *Y10T 29/49126*
 (2015.01); *Y10T 29/49128* (2015.01); *Y10T*
29/49155 (2015.01); *Y10T 29/49156* (2015.01);
Y10T 29/49165 (2015.01)

(56) **References Cited**

U.S. PATENT DOCUMENTS

4,687,695	A *	8/1987	Hamby	428/192
4,715,928	A *	12/1987	Hamby	216/18
5,121,297	A	6/1992	Haas	
5,799,392	A	9/1998	Mishiro	
5,854,534	A *	12/1998	Beilin et al.	257/691
6,242,279	B1 *	6/2001	Ho	H01L 21/4853 257/E23.069
6,324,067	B1 *	11/2001	Nishiyama	361/761
6,350,387	B2 *	2/2002	Caron et al.	430/314
6,384,339	B1 *	5/2002	Neuman	174/254
6,555,917	B1 *	4/2003	Heo	257/777
6,828,510	B1 *	12/2004	Asai	H05K 3/387 174/255
7,258,549	B2 *	8/2007	Asahi et al.	439/66
7,291,795	B2 *	11/2007	Maharshak et al.	200/292
7,338,290	B2	3/2008	Motohashi et al.	
7,415,761	B2	8/2008	Hirose et al.	
7,423,219	B2 *	9/2008	Kawaguchi et al.	174/254
7,488,428	B2 *	2/2009	Lee	H05K 3/0035 216/13
7,601,919	B2	10/2009	Phan et al.	
7,729,570	B2 *	6/2010	Yamada	G02B 6/12002 385/14
7,759,582	B2 *	7/2010	Takahashi et al.	174/264
7,982,135	B2 *	7/2011	Takahashi	H05K 3/4691 174/254
8,035,983	B2	10/2011	Takahashi et al.	
8,071,883	B2 *	12/2011	Takahashi	H05K 3/4691 174/254
8,238,109	B2 *	8/2012	Sagisaka	H05K 3/4691 174/254
8,354,596	B2 *	1/2013	Takahashi	H05K 3/4691 174/254
8,404,978	B2 *	3/2013	Naganuma	H05K 3/4691 174/254
8,431,829	B2 *	4/2013	Takahashi	H01L 24/24 174/255
8,479,389	B2 *	7/2013	Takahashi	H05K 3/4691 156/150

8,609,991	B2 *	12/2013	Takahashi	H05K 3/4691 174/254
2001/0010303	A1 *	8/2001	Caron et al.	216/18
2003/0164548	A1 *	9/2003	Lee	257/738
2005/0217895	A1 *	10/2005	Maharshak et al.	174/262
2005/0243528	A1 *	11/2005	Murayama	H05K 1/148 361/760
2006/0169485	A1 *	8/2006	Kawaguchi	H05K 3/4691 174/254
2006/0281343	A1 *	12/2006	Uchida et al.	439/67
2007/0012475	A1 *	1/2007	Kawaguchi et al.	174/255
2007/0013041	A1 *	1/2007	Ishigaki	H05K 3/4691 257/686
2007/0126123	A1 *	6/2007	Sawachi	257/777
2007/0202306	A1 *	8/2007	Nikaldo	H05K 1/148 428/195.1
2007/0281505	A1 *	12/2007	Kobayashi et al.	439/69
2008/0014768	A1	1/2008	Lee et al.	
2008/0093118	A1	4/2008	Takahashi et al.	
2008/0099230	A1	5/2008	Takahashi et al.	
2008/0168651	A1	7/2008	Bhatt et al.	
2008/0289859	A1	11/2008	Mikado et al.	
2009/0014205	A1 *	1/2009	Kobayashi et al.	174/255
2009/0229876	A1	9/2009	Takahashi	
2009/0255111	A1 *	10/2009	Takahashi et al.	29/852

FOREIGN PATENT DOCUMENTS

EP	1 566 993	A1	8/2005
JP	63-293991		11/1988
JP	03-246986		11/1991
JP	05-090756		4/1993
JP	05-315758		11/1993
JP	06-216537		8/1994
JP	07-094835		4/1995
JP	2003-152309		5/2003
JP	2005-311244		11/2005
JP	2005-322878		11/2005
JP	2006-73819		3/2006
JP	2006-100703		4/2006
JP	2006-100704		4/2006
JP	2006-128360		5/2006
JP	2006-140213		6/2006
JP	2006-196800		7/2006
JP	2006-294666		10/2006
JP	2007-273654		10/2007
JP	4021472	B1	10/2007
JP	4024846	B1	10/2007
JP	2008-034511		2/2008
TW	478306		3/2002
WO	93/11652		6/1993
WO	2004/093508	A1	10/2004
WO	2004/098252	A1	11/2004

* cited by examiner

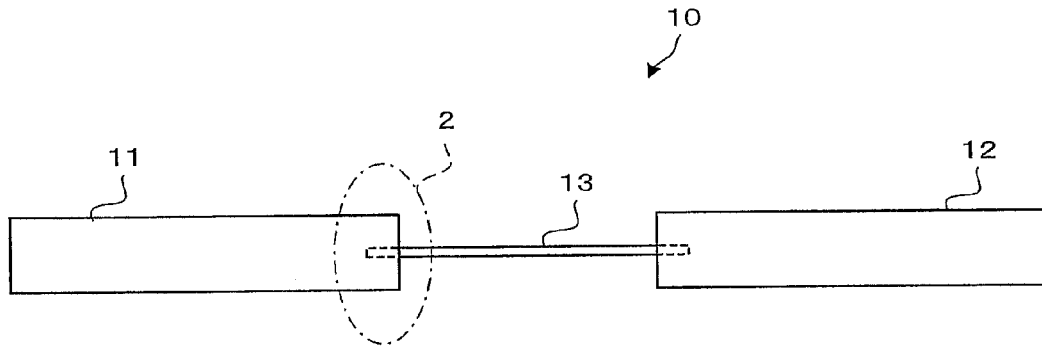

FIG. 1A

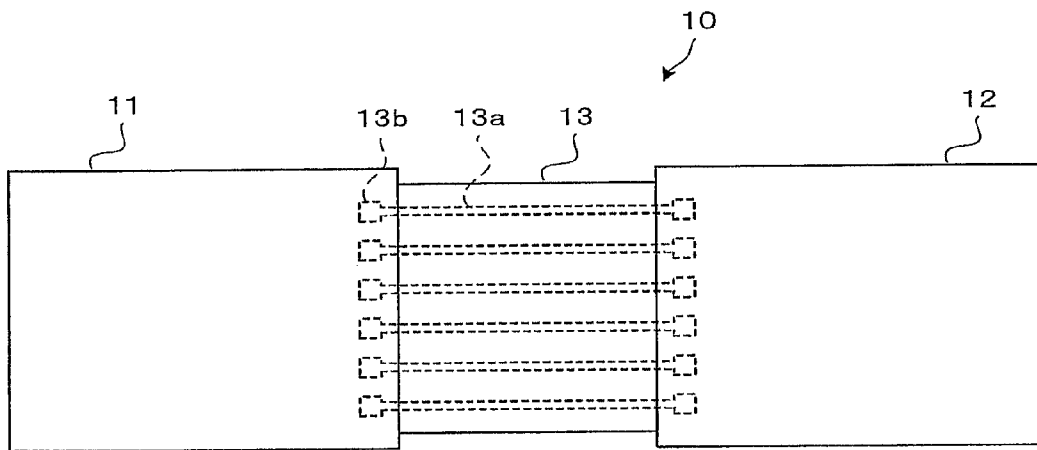

FIG. 1B

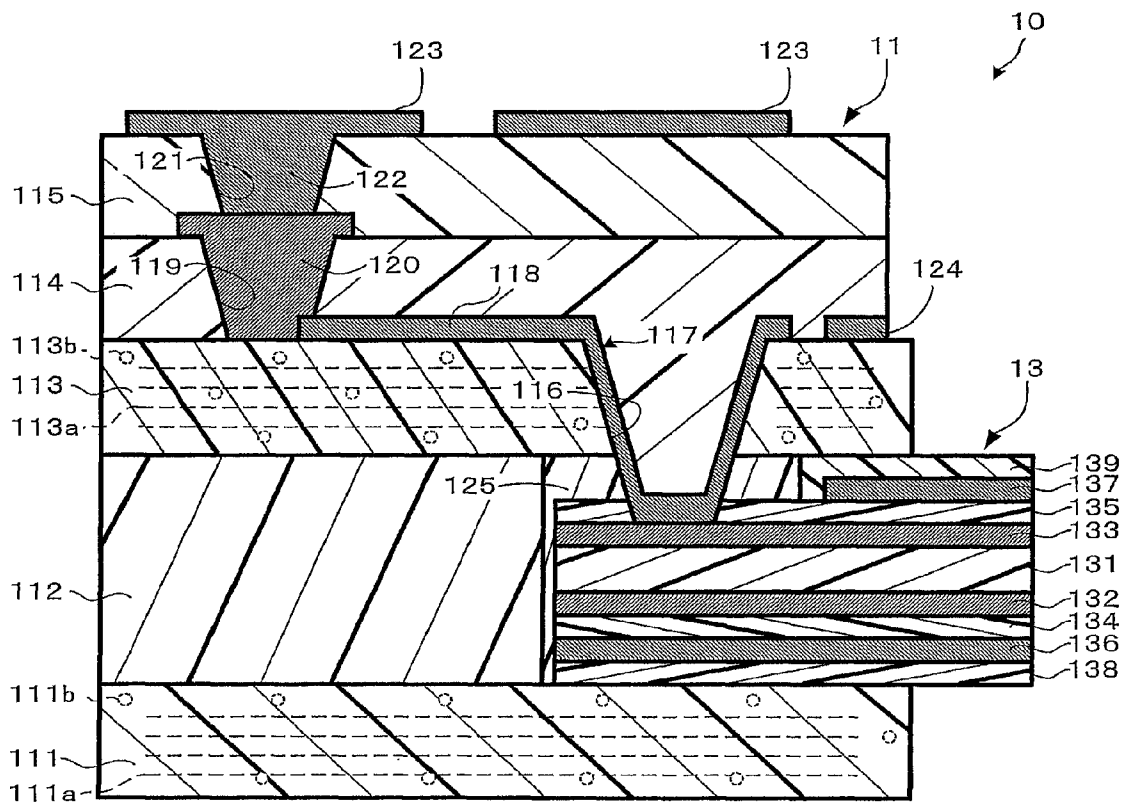

FIG. 2

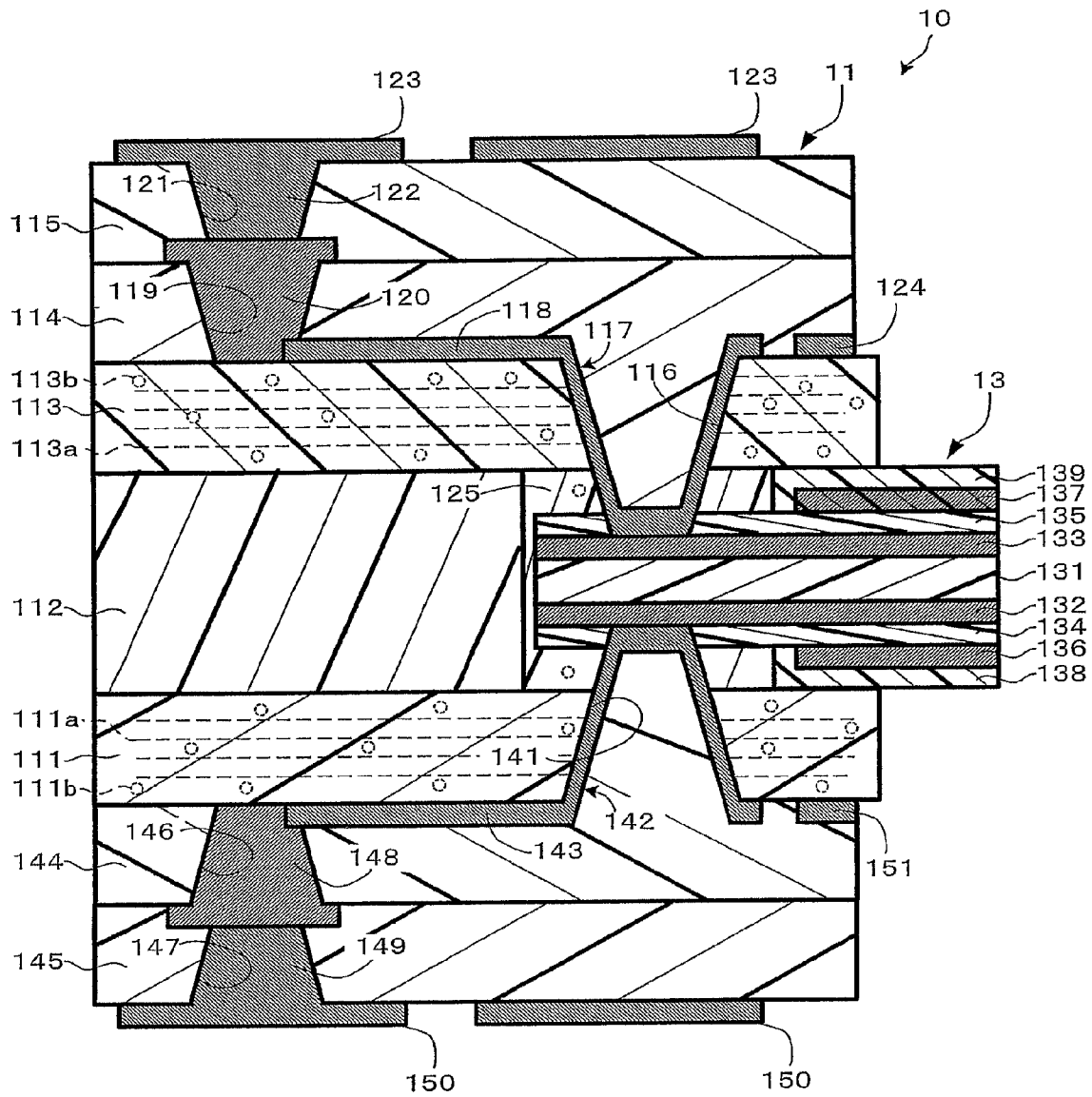

FIG. 3

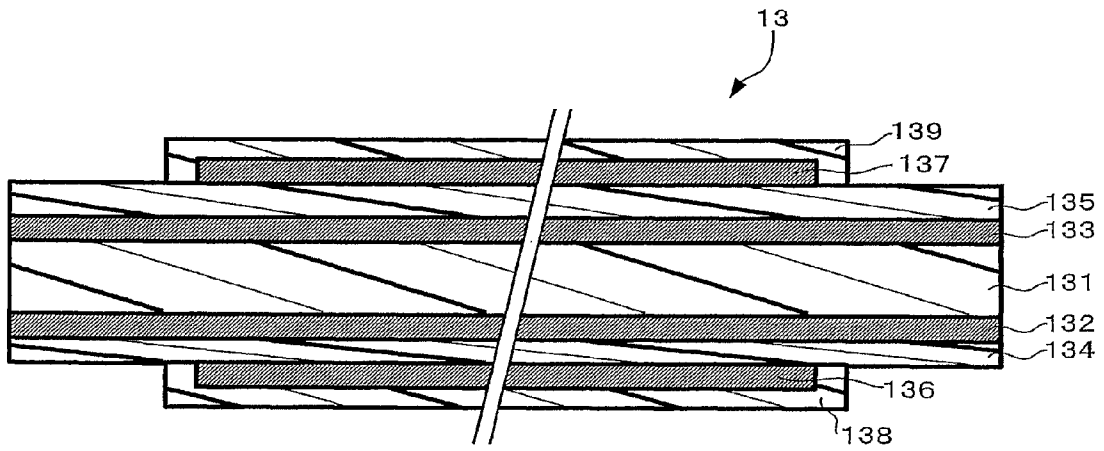
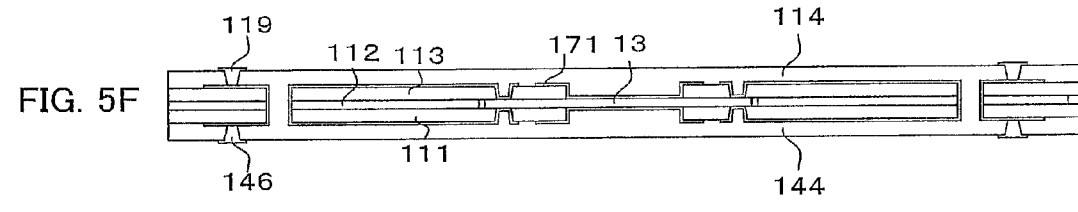
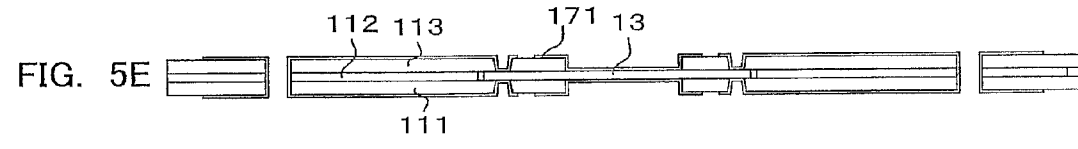
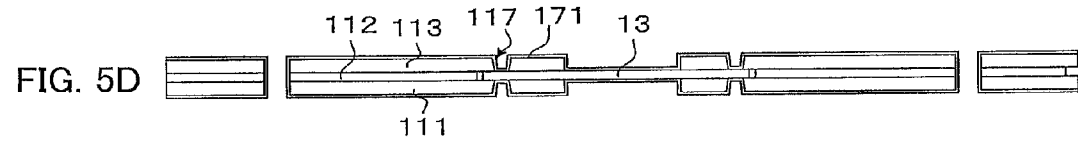
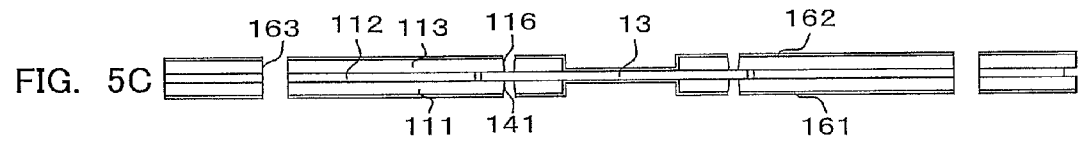
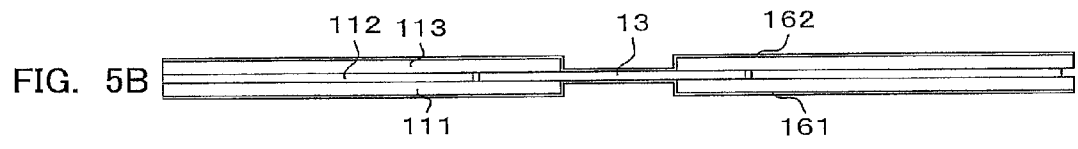
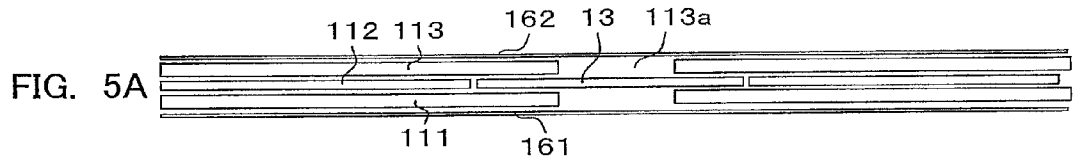
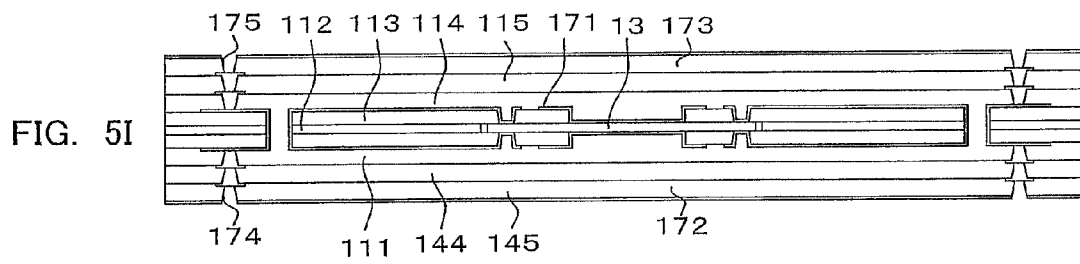
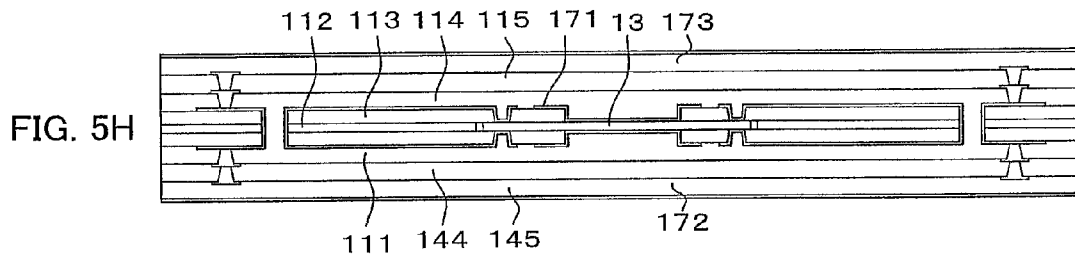
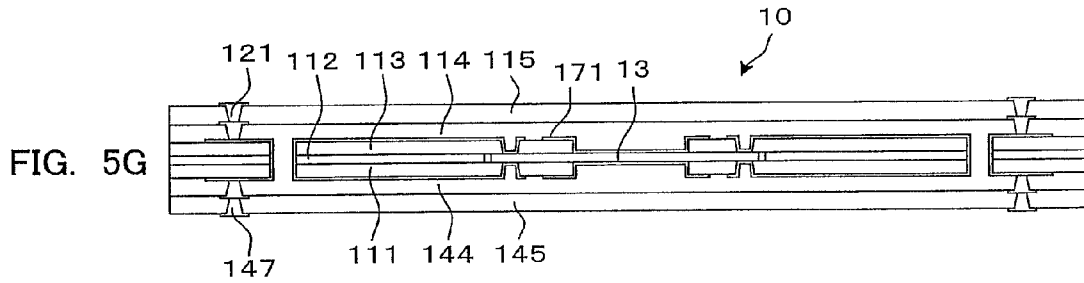
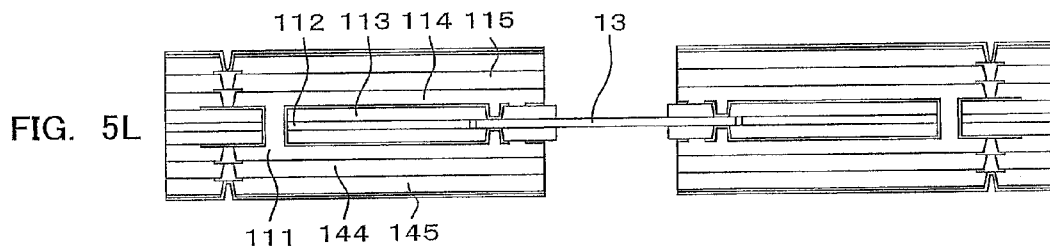
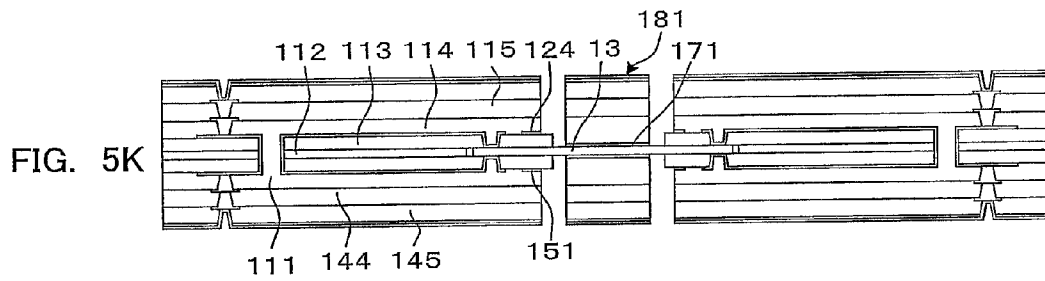
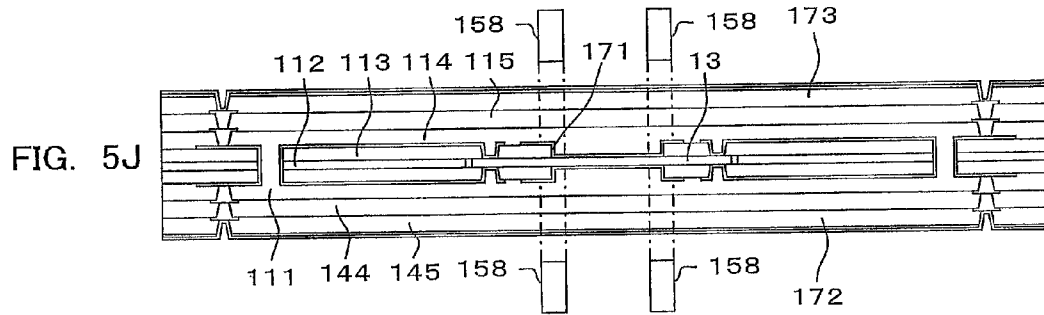
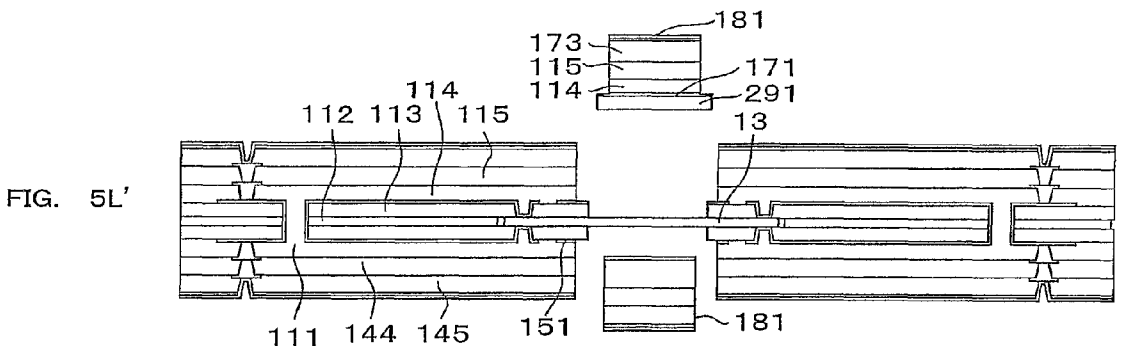
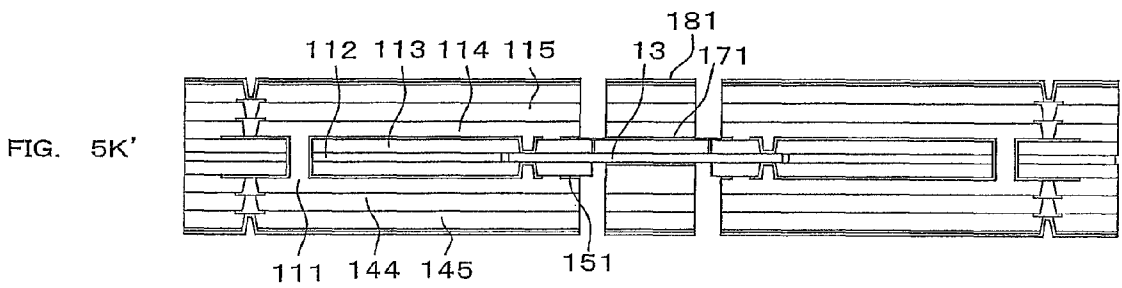
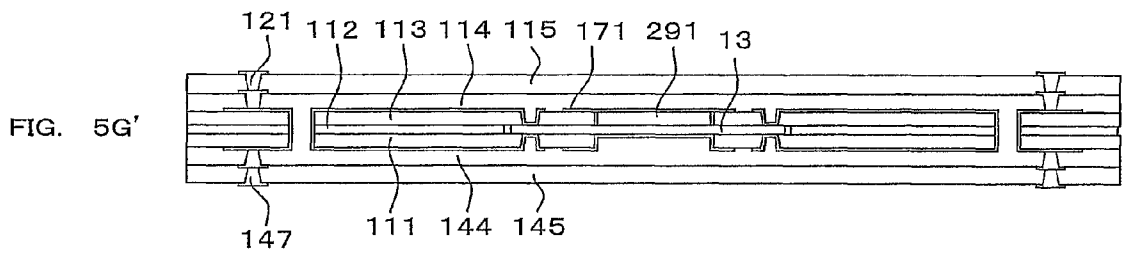
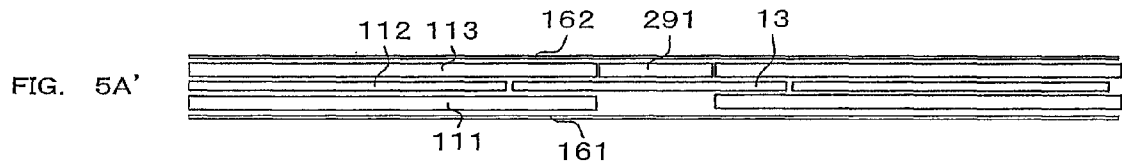

FIG. 4









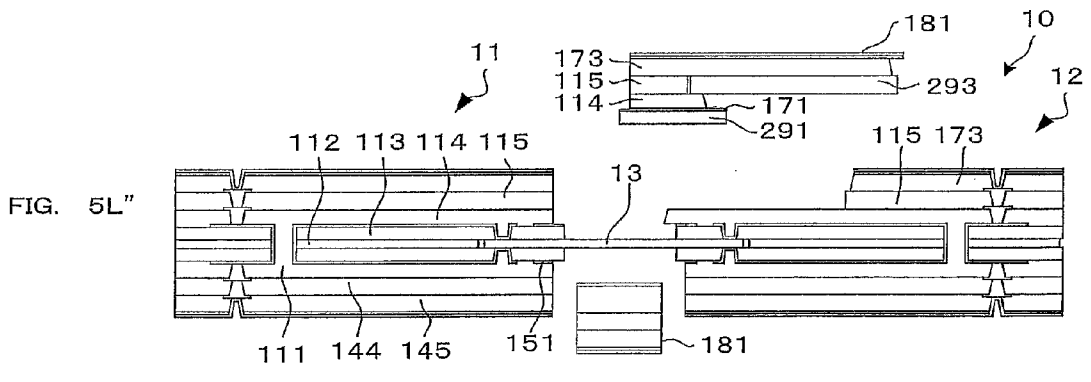
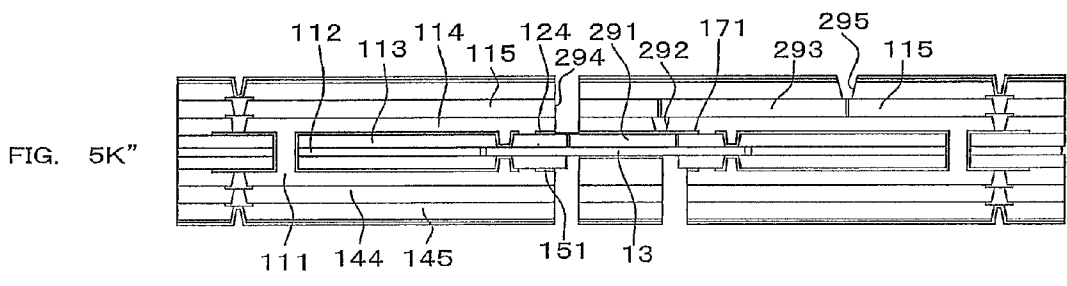
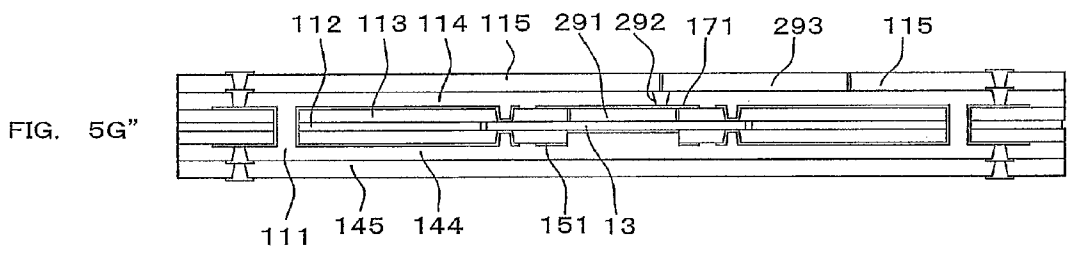
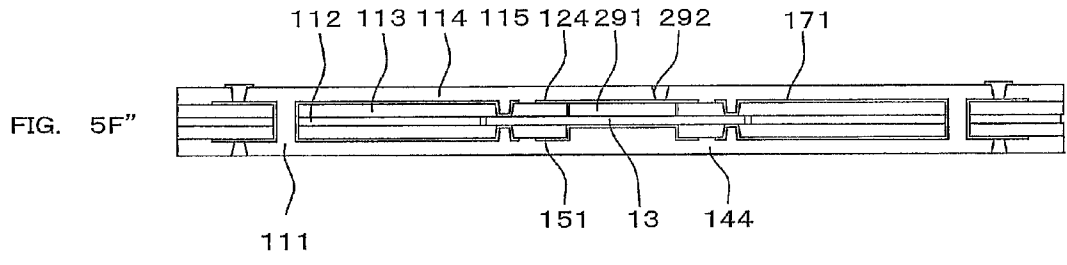

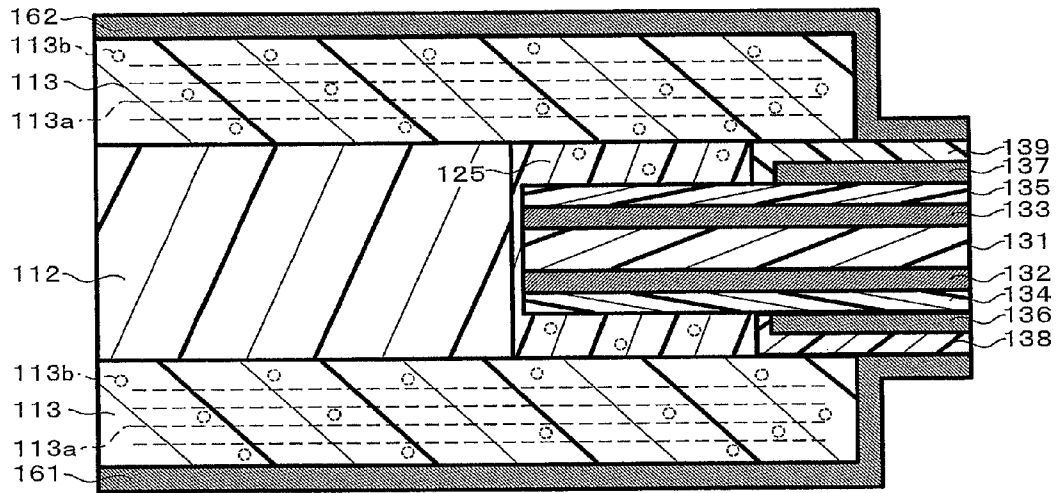

FIG. 6A

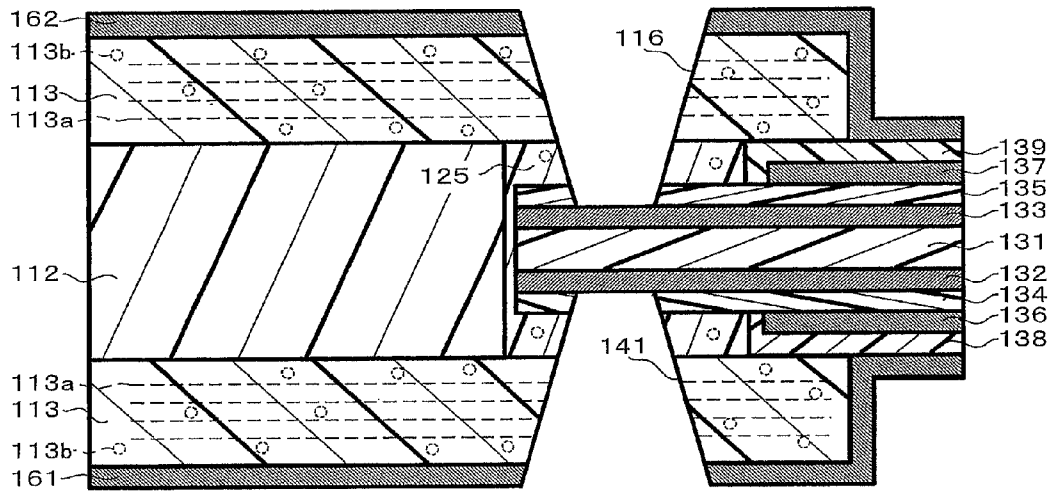

FIG. 6B

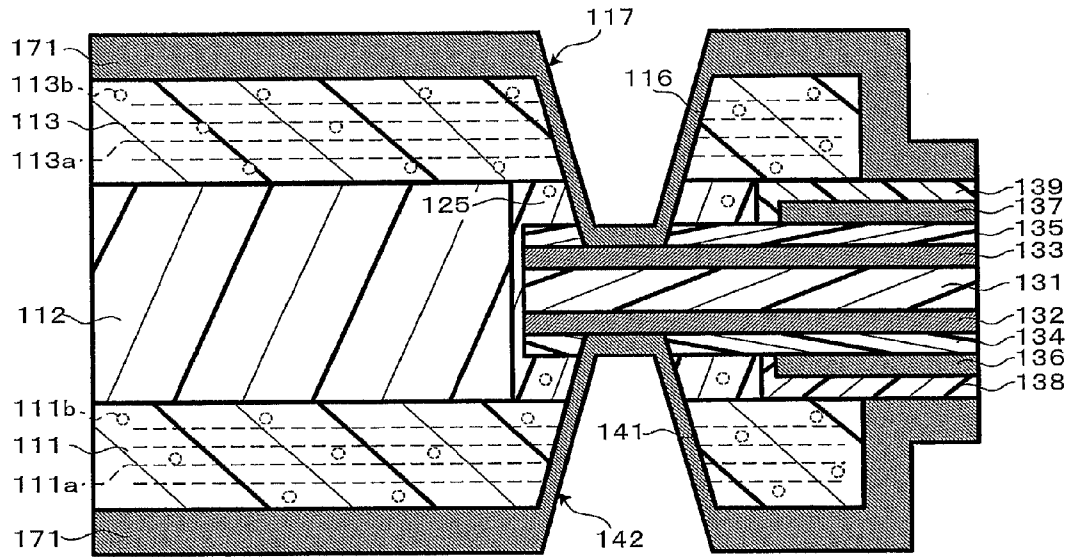

FIG. 6C

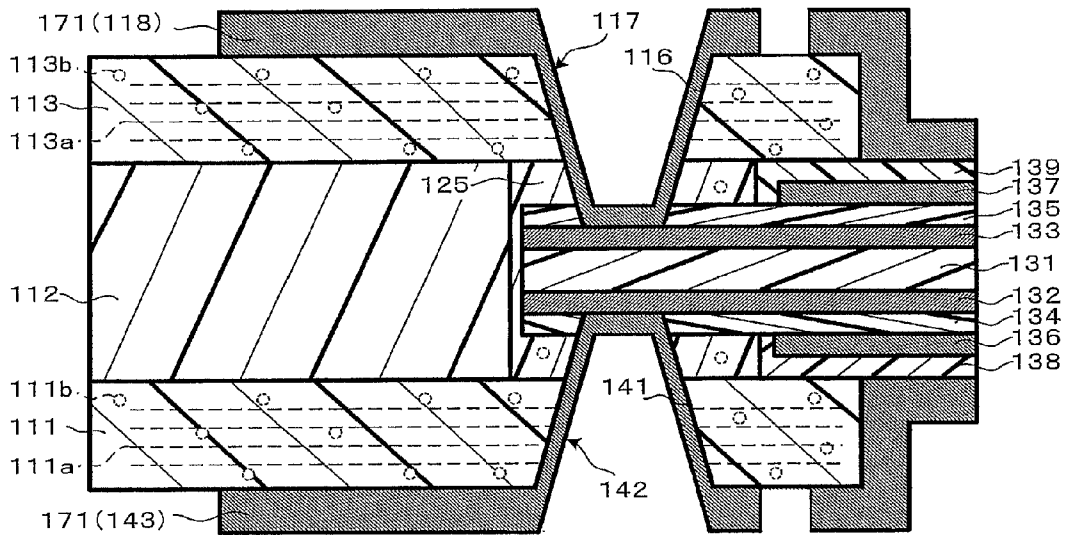

FIG. 6D

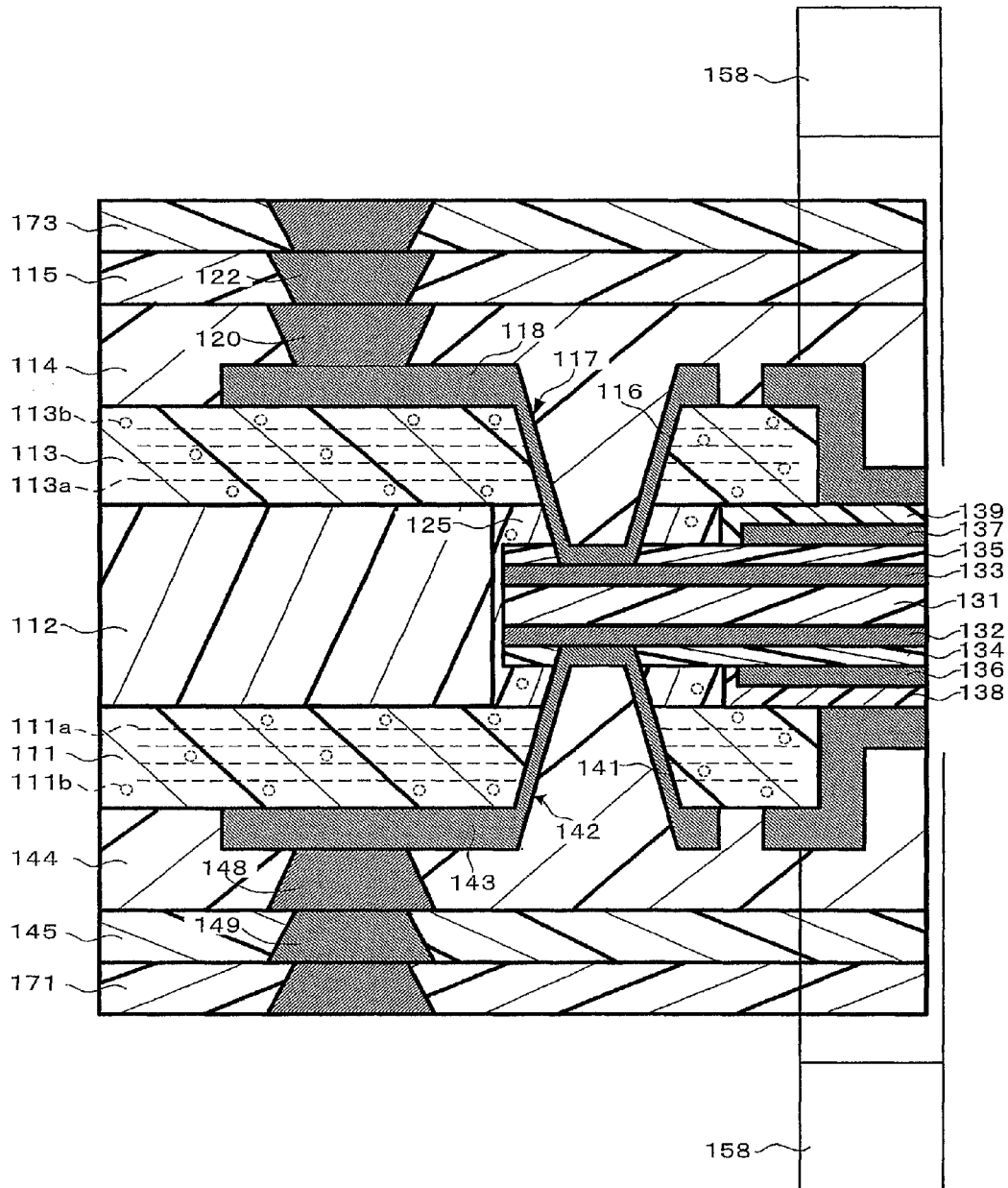

FIG. 6E

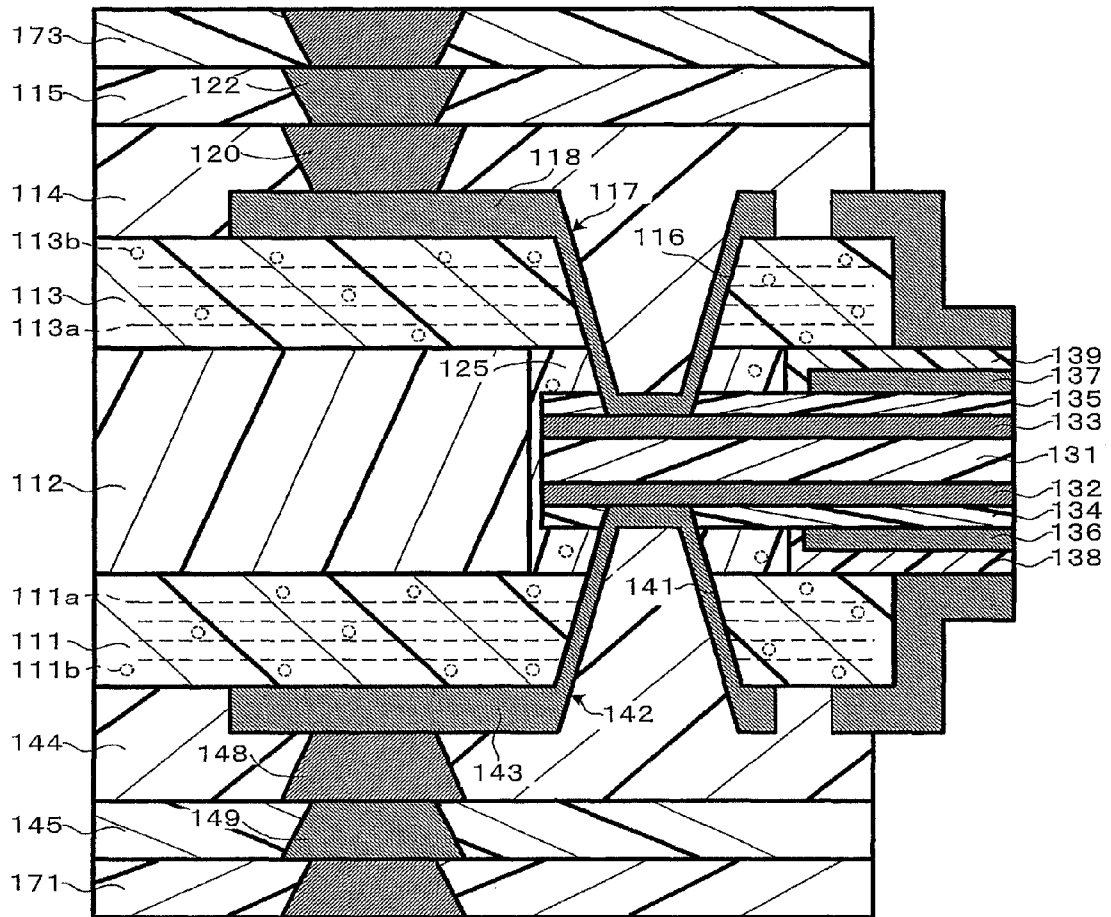

FIG. 6F

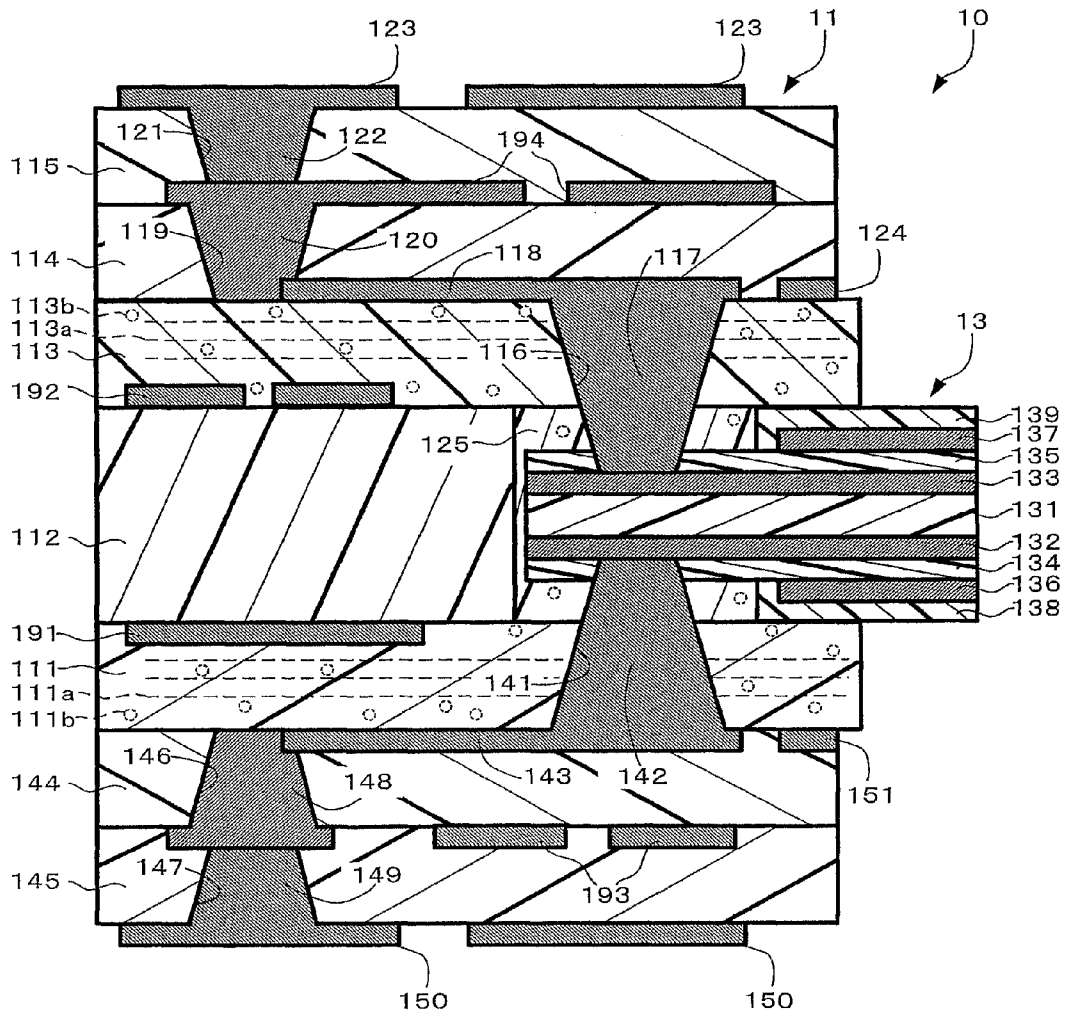

FIG. 7

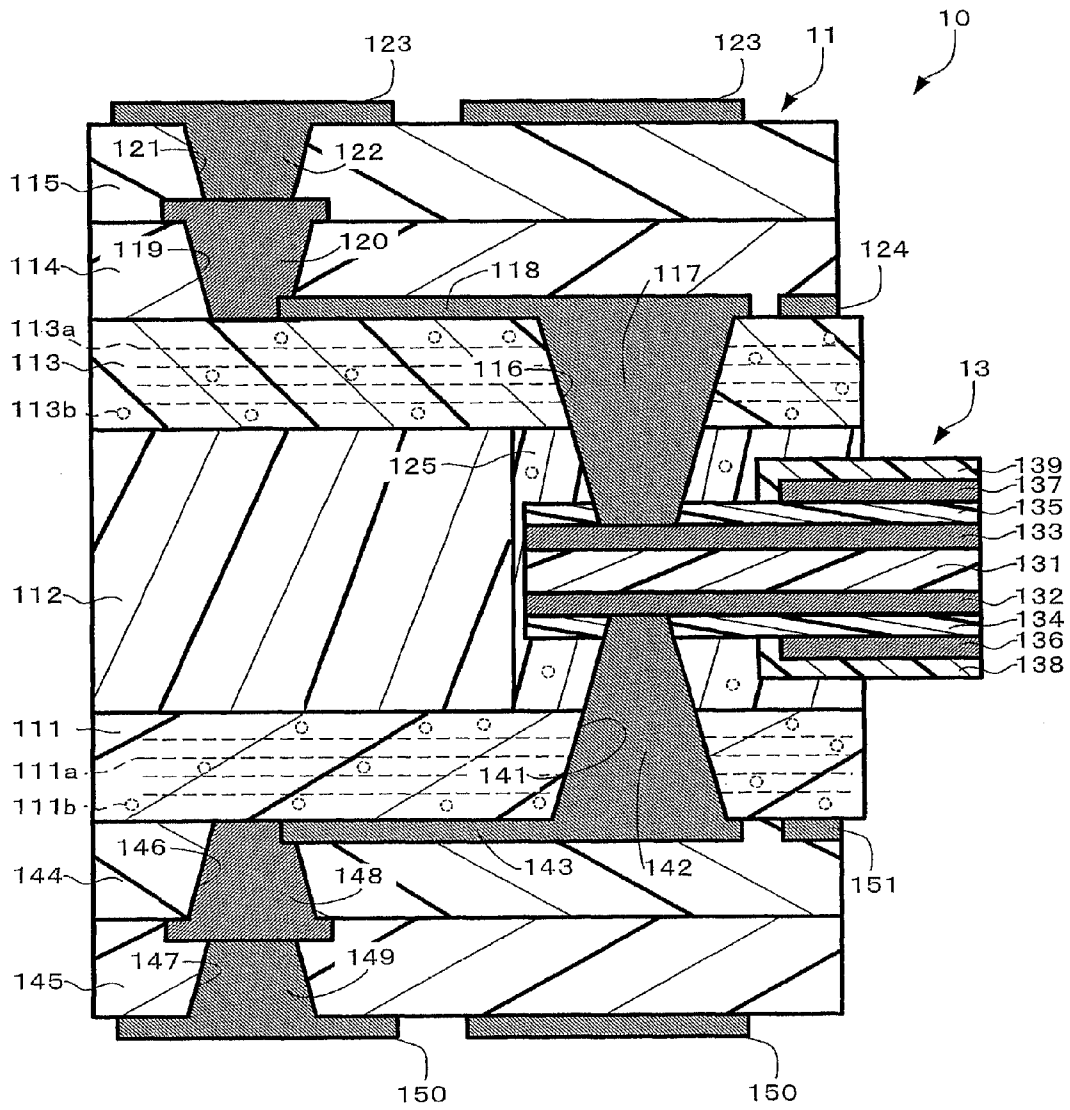

FIG. 8

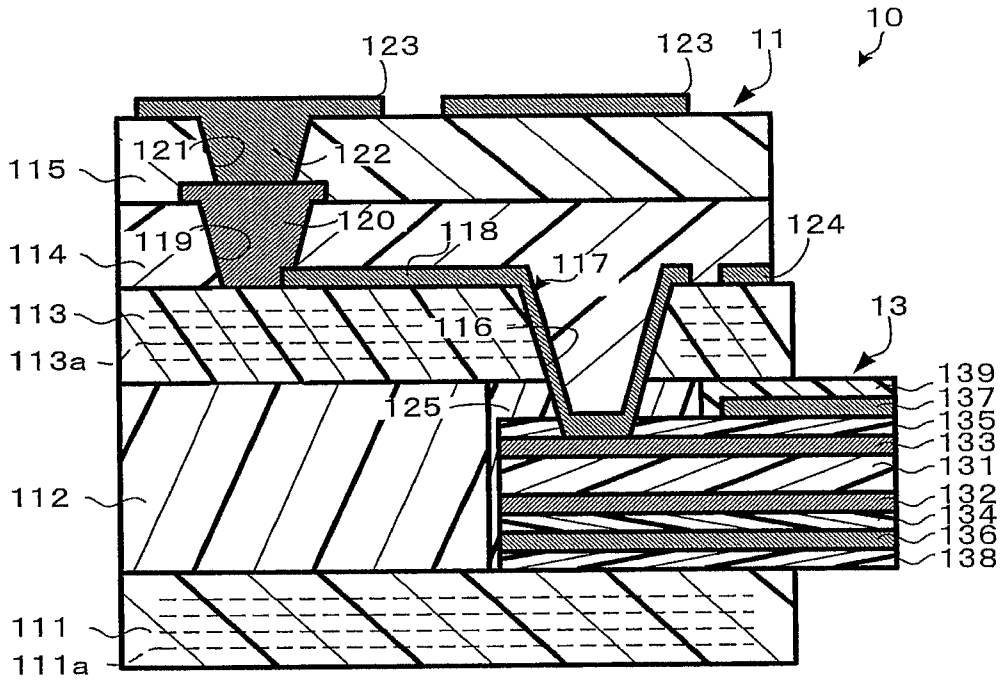

FIG. 9A

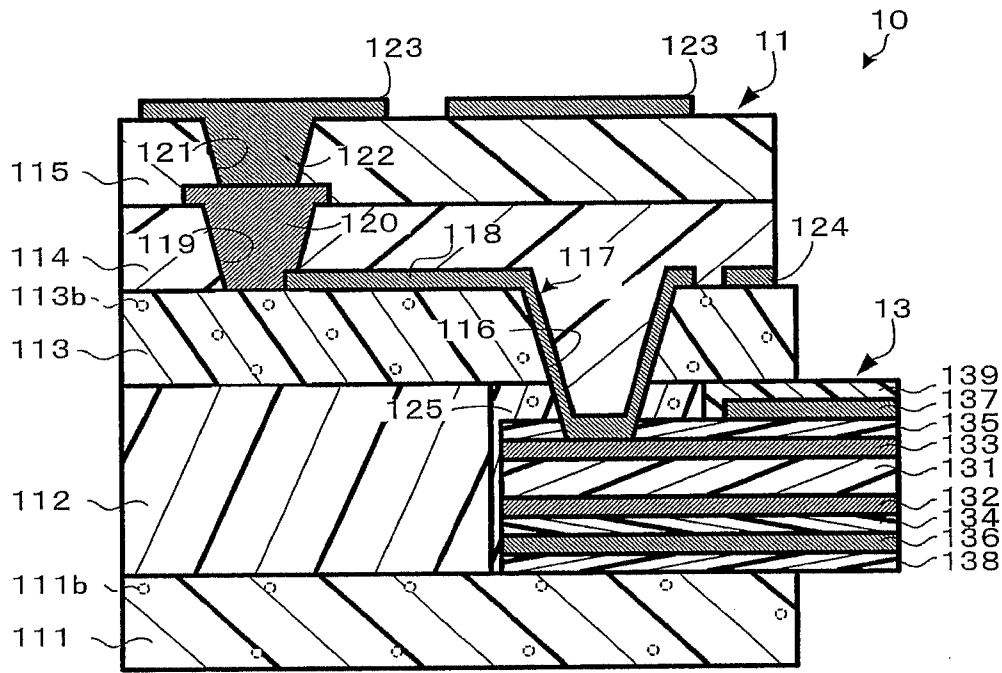

FIG. 9B

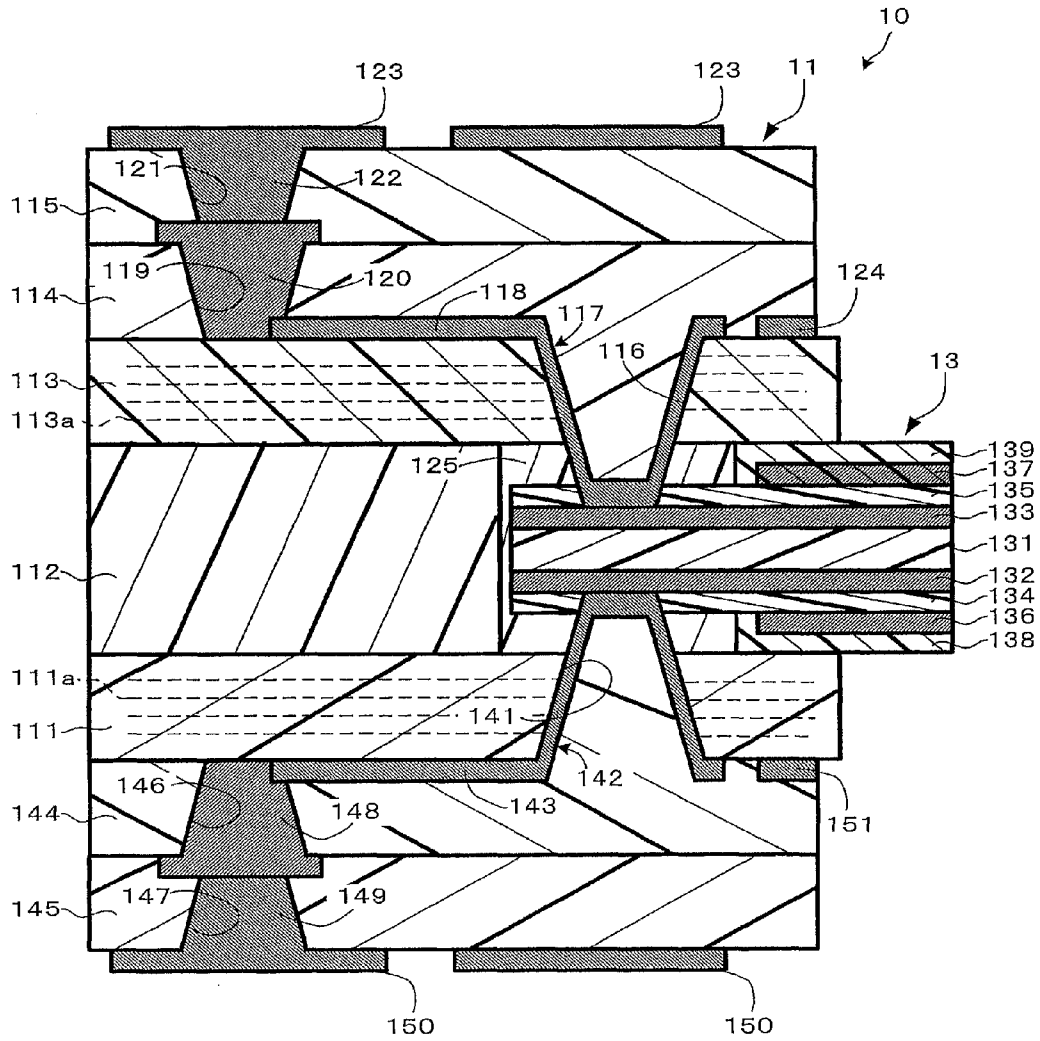

FIG. 10A

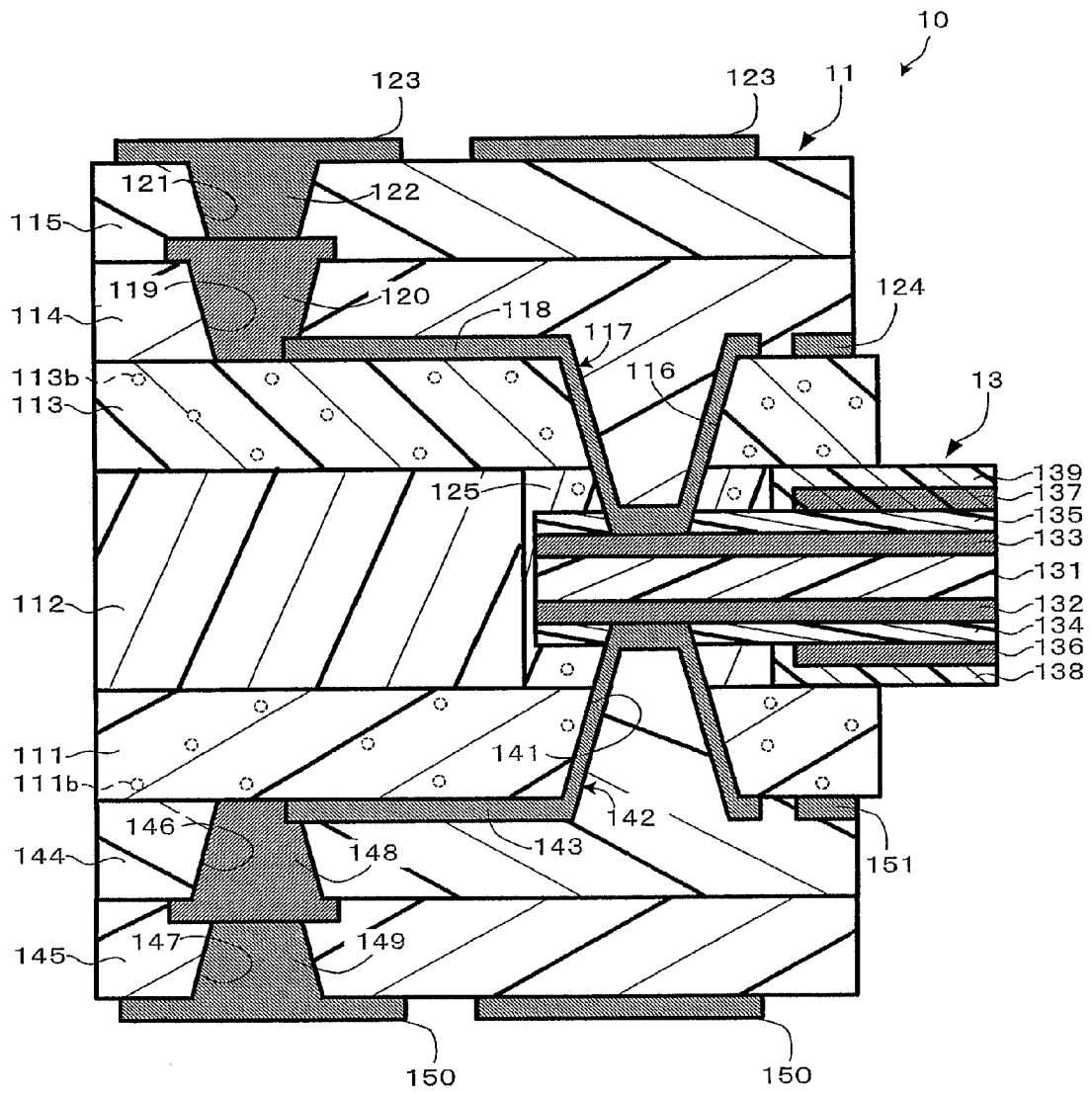

FIG. 10B

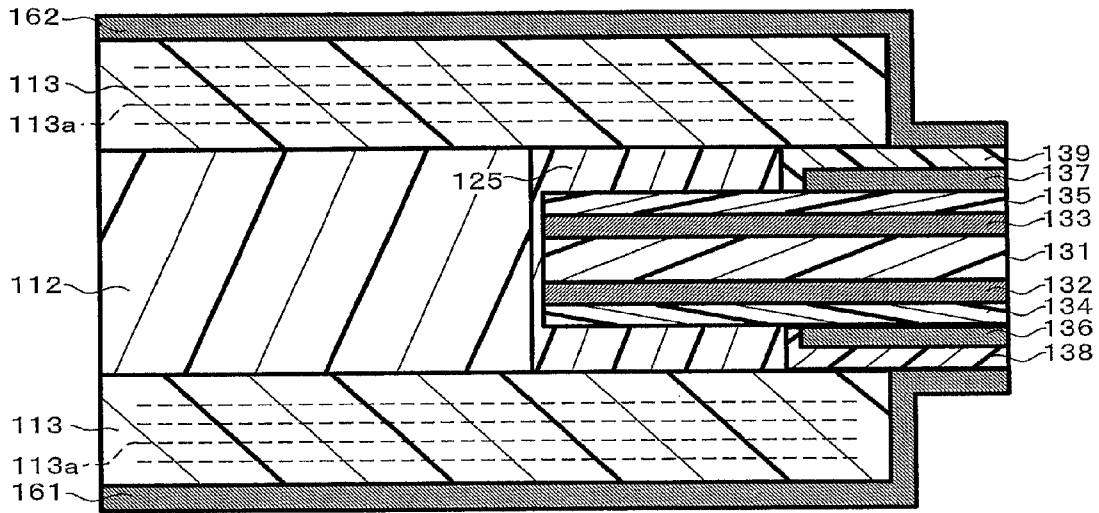

FIG. 11A

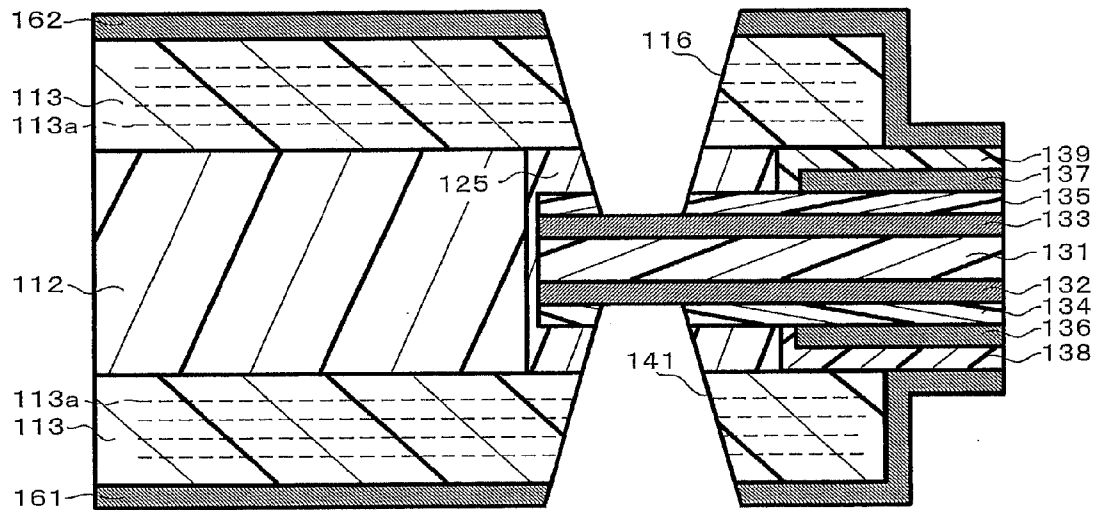

FIG. 11B

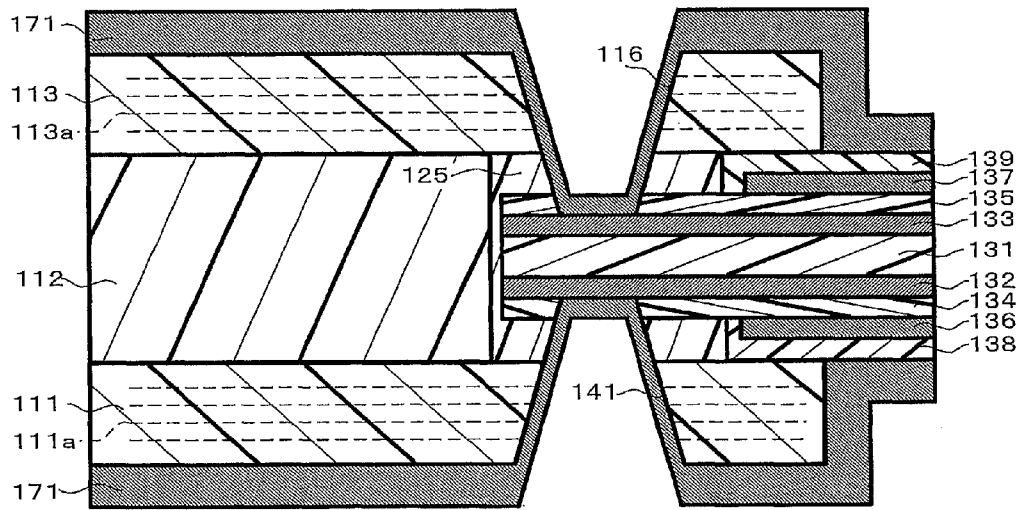

FIG. 11C

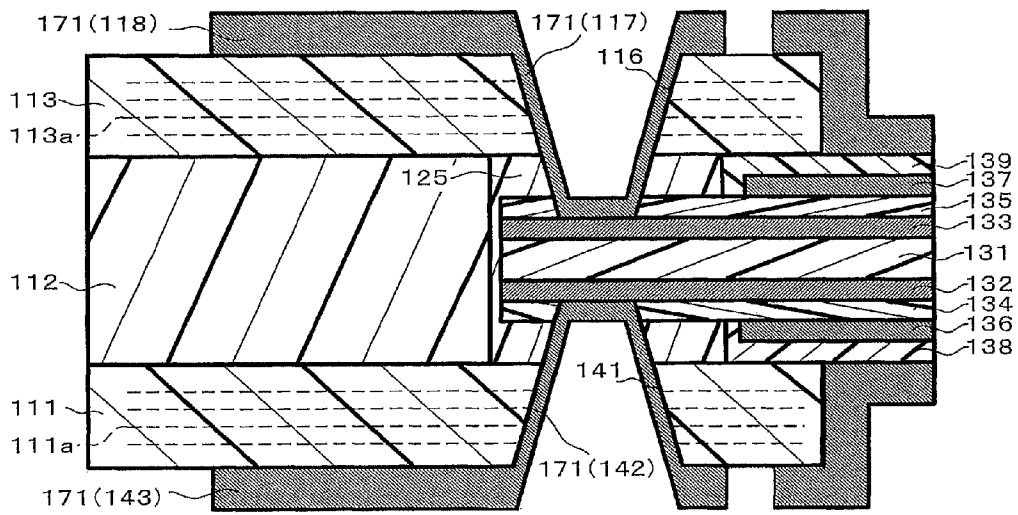

FIG. 11D

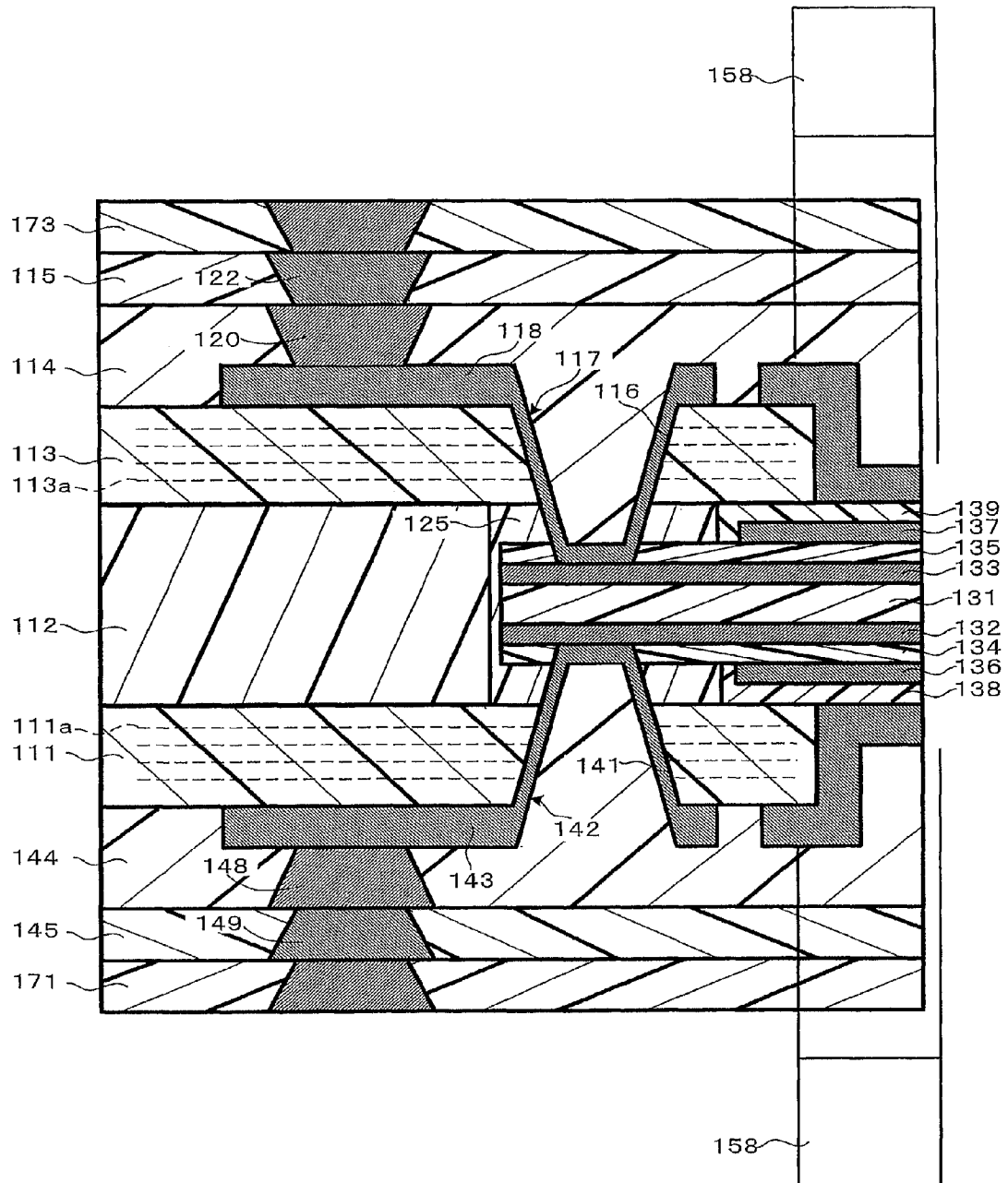

FIG. 11E

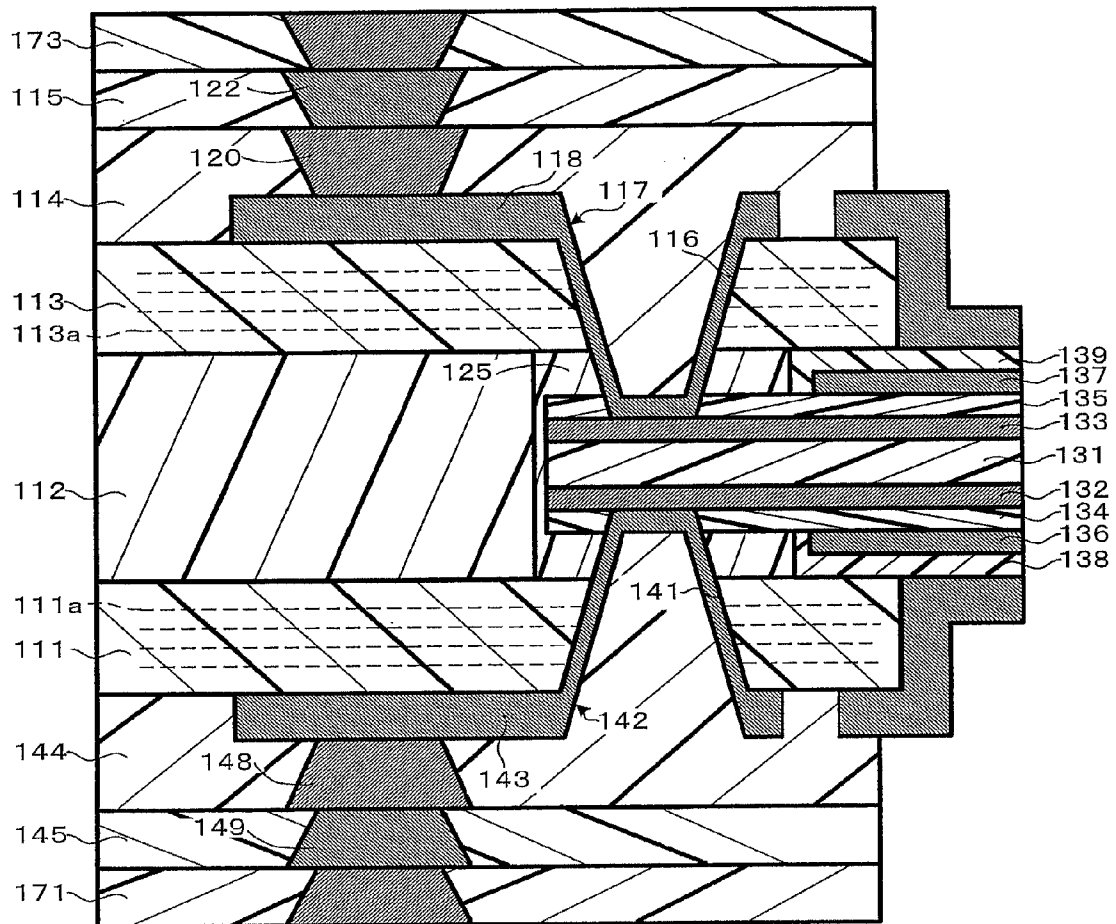

FIG. 11F

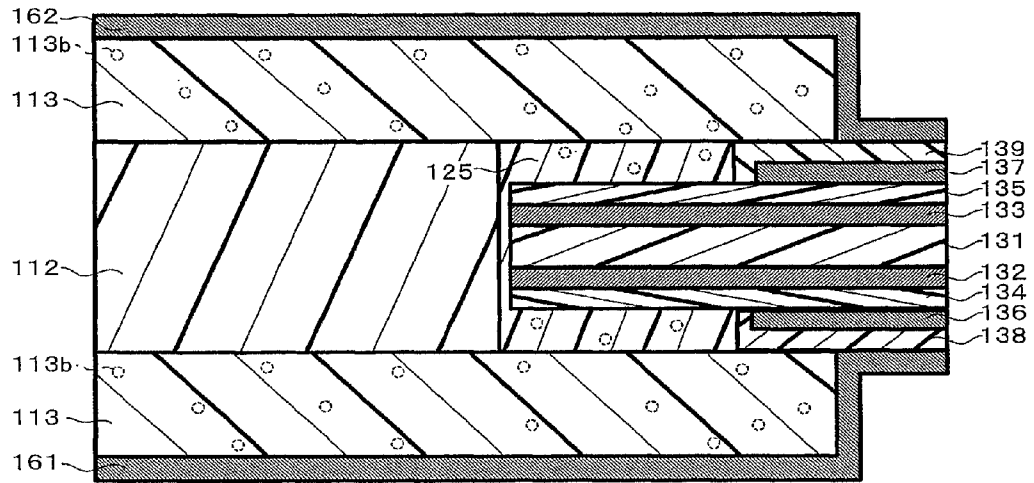

FIG. 12A

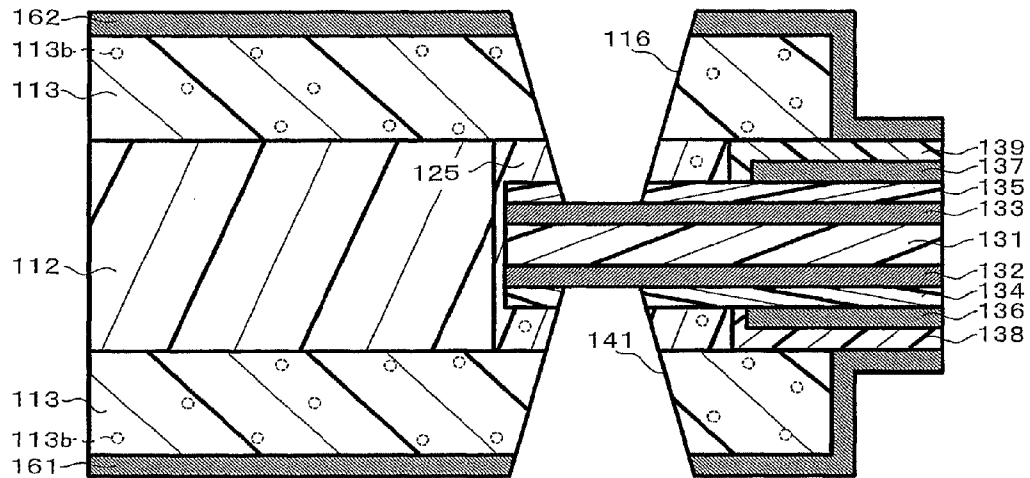

FIG. 12B

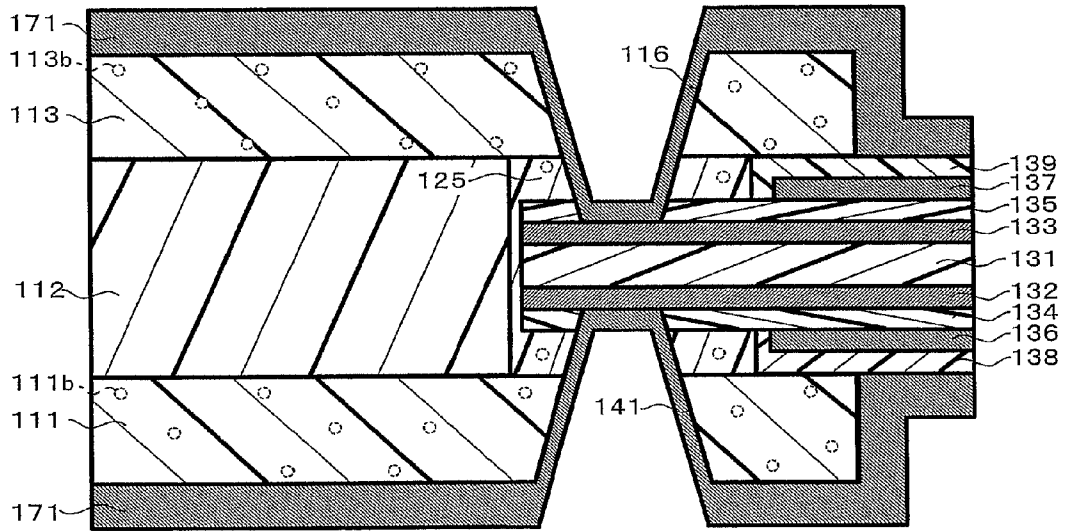

FIG. 12C

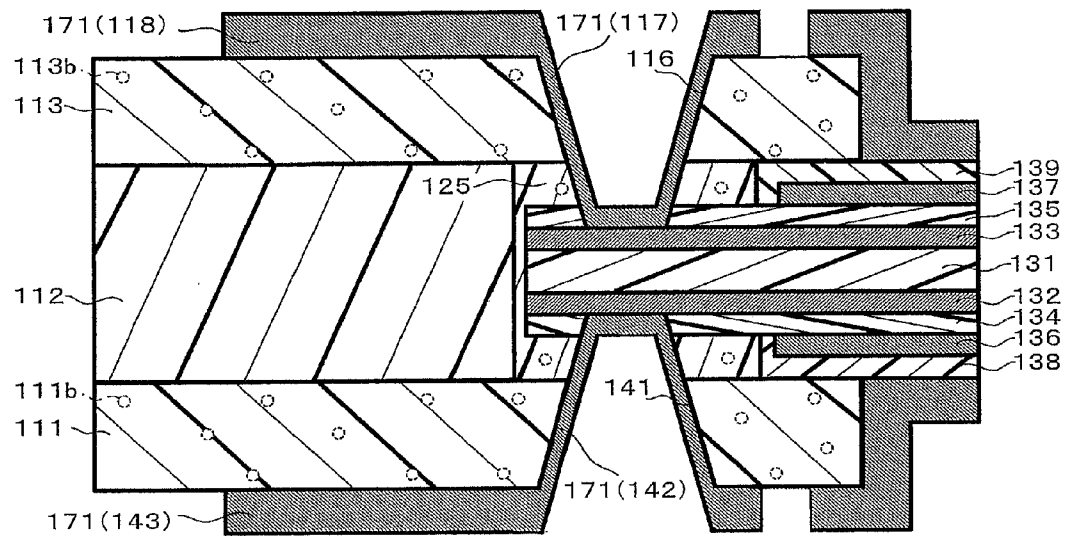

FIG. 12D

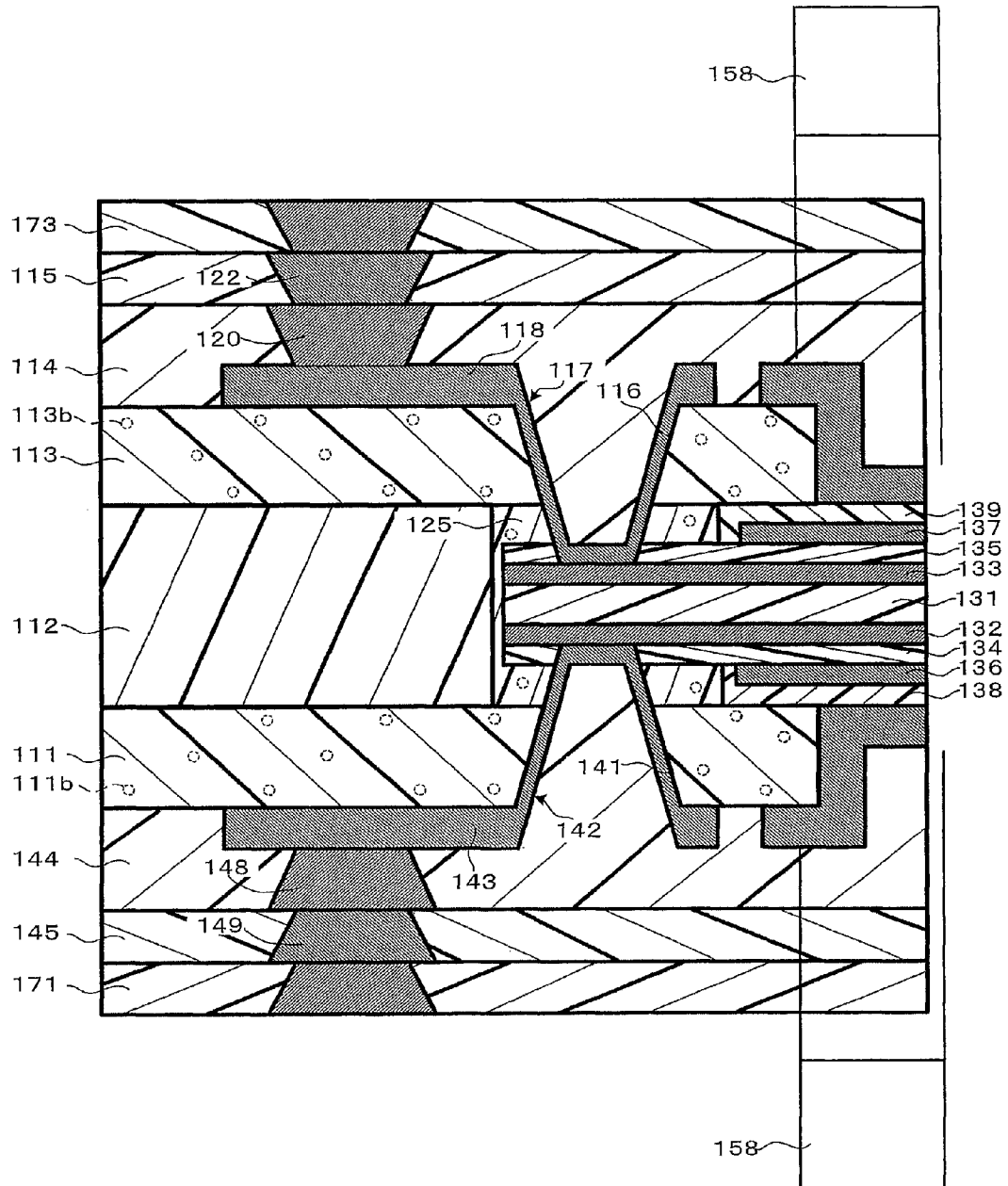

FIG. 12E

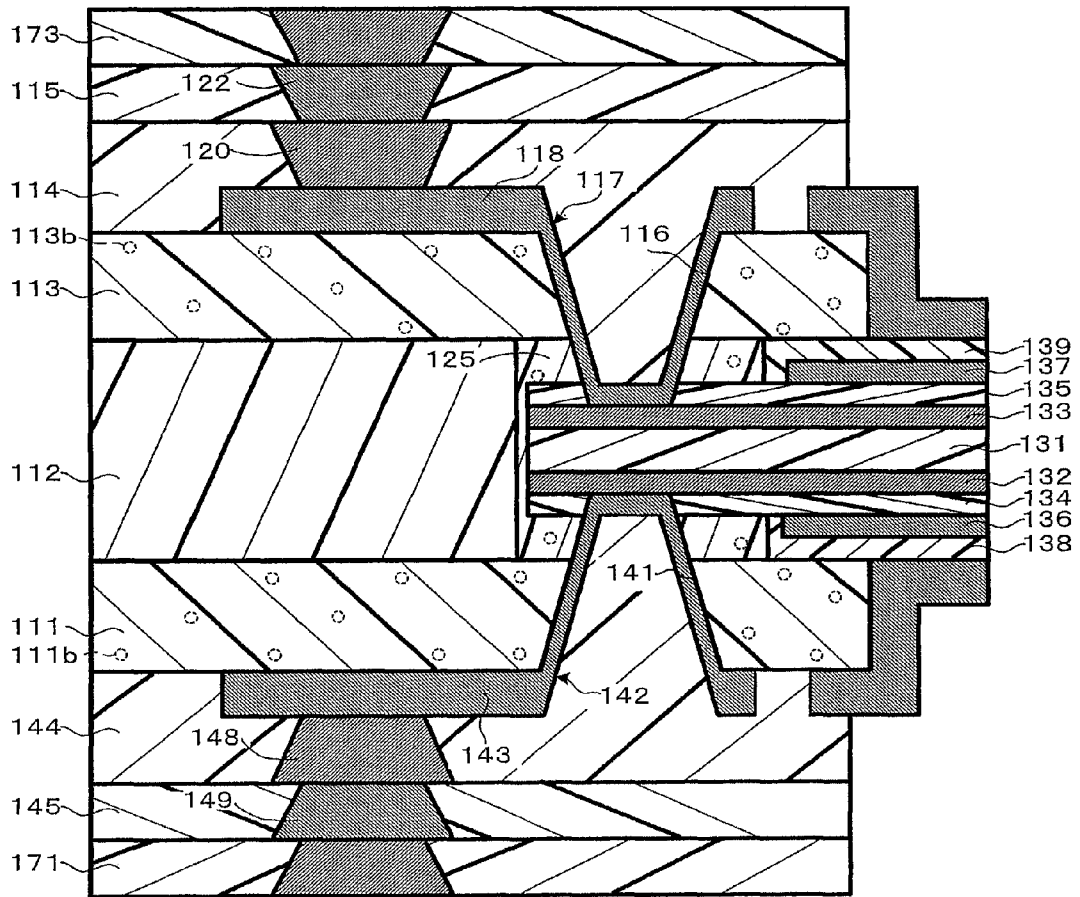

FIG. 12F

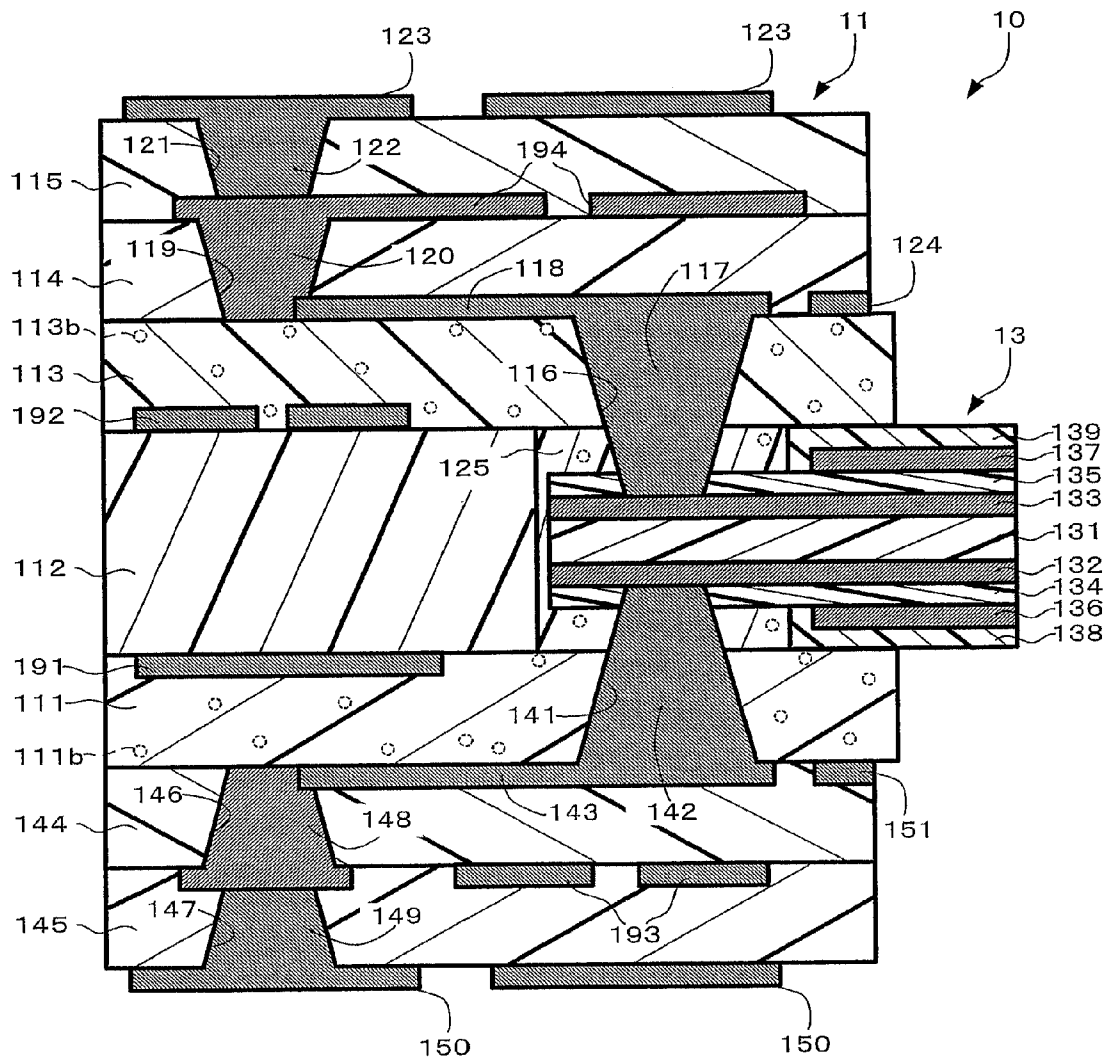

FIG. 13B

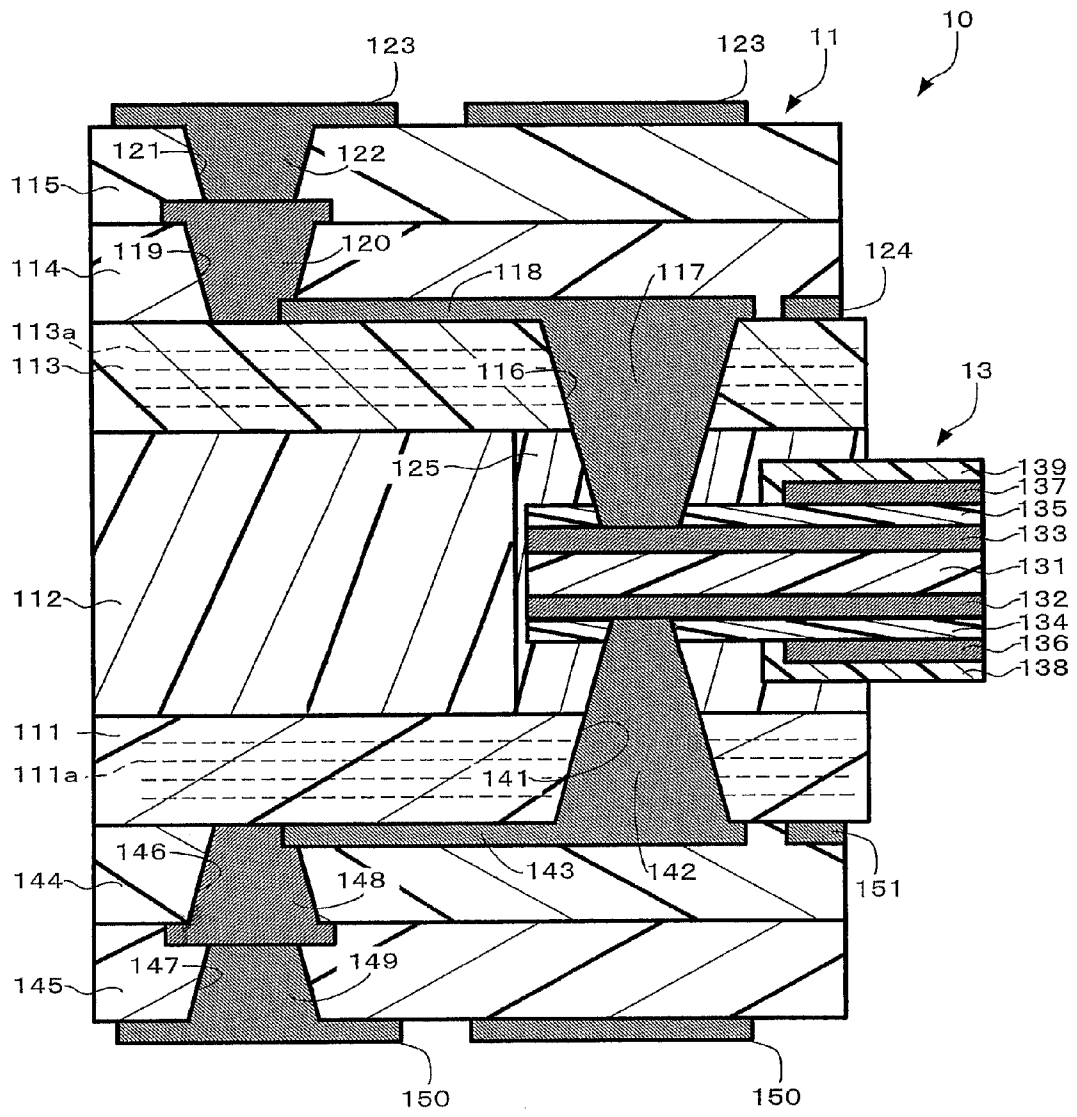

FIG. 14A

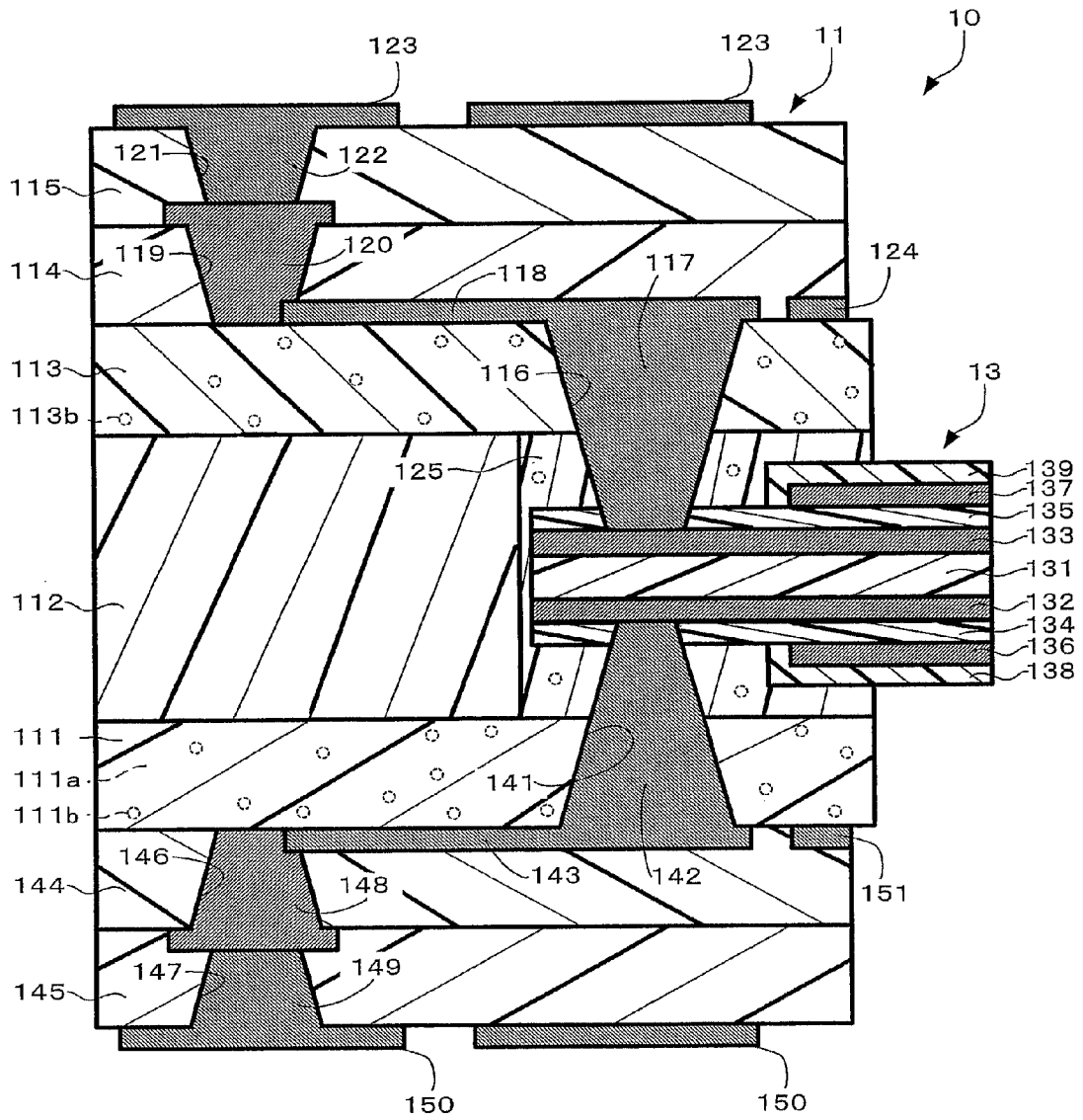

FIG. 14B

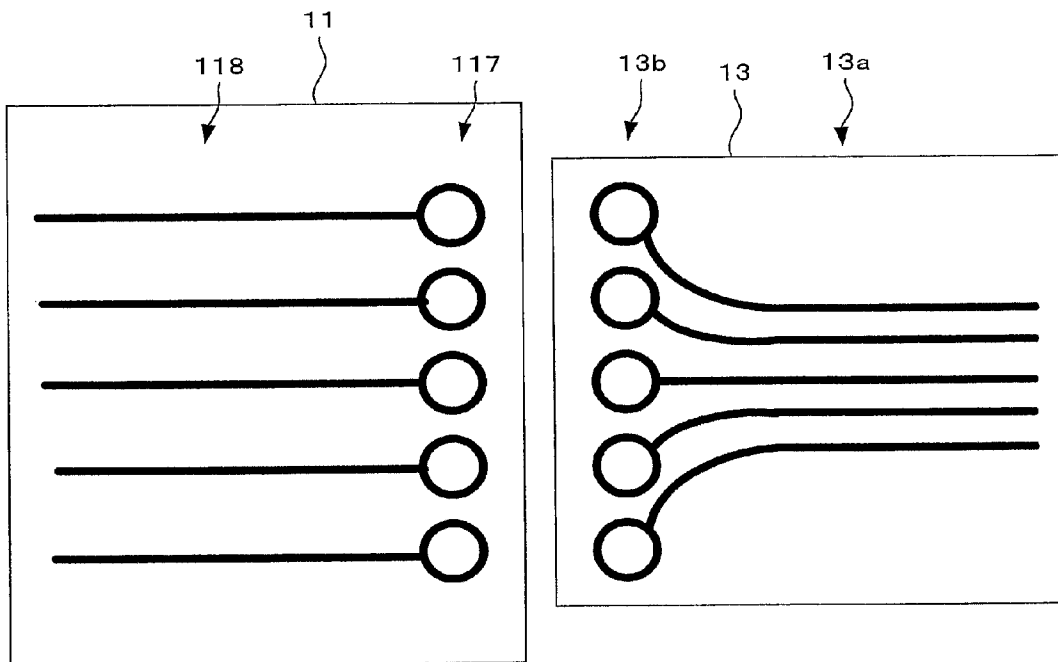

FIG . 15

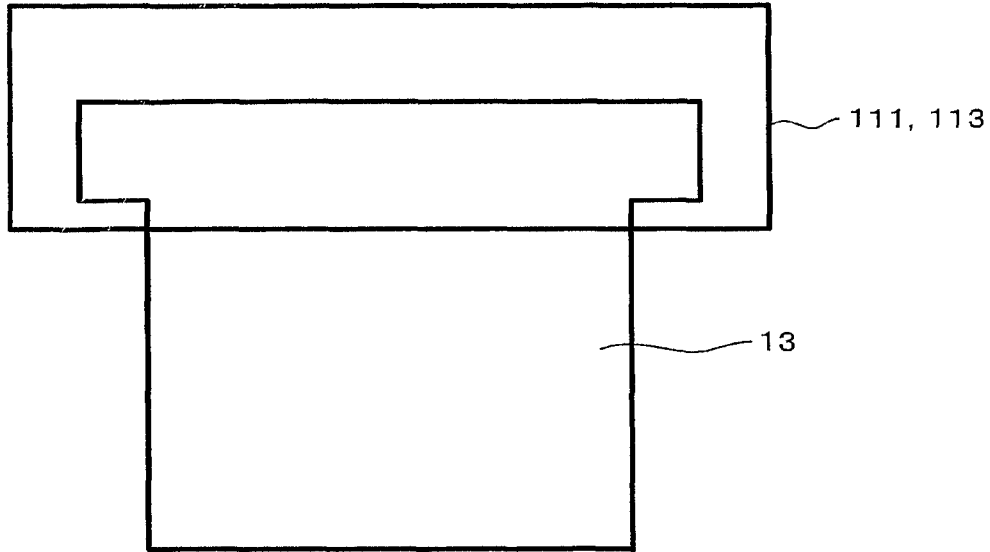

FIG. 16

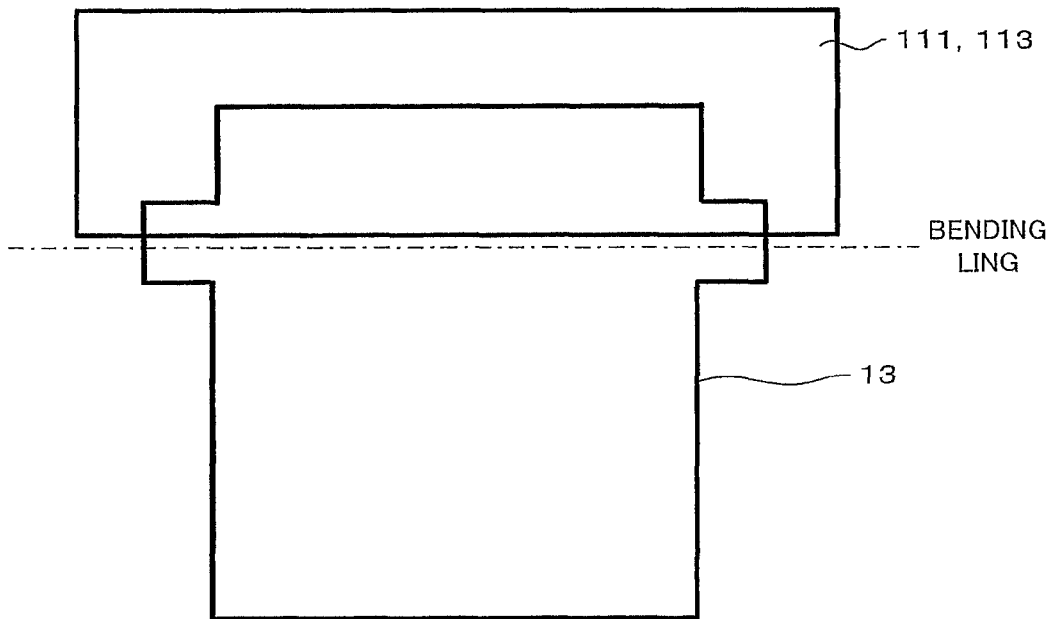

FIG. 17

FLEX-RIGID WIRING BOARD AND METHOD OF MANUFACTURING THE SAME

CROSS-REFERENCE TO RELATED APPLICATIONS

The present application is a continuation of and claims the benefit of priority from U.S. patent application Ser. No. 12/574,309, filed Oct. 6, 2009, which is a divisional of U.S. patent application Ser. No. 11/927,144, filed Oct. 29, 2007, now U.S. Pat. No. 7,982,135, issued Jul. 19, 2011, which is based on and claims the benefit of priority to U.S. Application No. 60/863,396, filed Oct. 30, 2006. The entire contents of these applications are incorporated herein by reference.

BACKGROUND OF THE INVENTION

1. Field of the Invention

The present invention relates to a flexible wiring board having a flexible portion and a method of manufacturing the flexible wiring board.

2. Discussion of the Background

A flex-rigid wiring board, a part of which has rigidity, and the other part of which has flexibility, is described, for example, in Japanese Unexamined Patent Application Publication Nos. 2006-140213 and 2006-100703, and PCT International Publication WO2004/093508.

A flex-rigid wiring board described in Japanese Unexamined Patent Application Publication No. 2006-140213 has core boards which are rigid portions, a flexible board disposed adjacent to the core boards in a horizontal direction, flexible adhesive layers laminated on the core boards and the flexible board, wiring patterns formed on the flexible adhesive layers located on the rigid portions, and blind vias and/or through-holes connecting the wiring patterns formed on individual layers. In the structure described above, the flexible adhesive layer is laminated on the flexible board.

Japanese Unexamined Patent Application Publication No. 2006-100703 describes a method for manufacturing a flex-rigid wiring board. In that method, first, rigid boards each having a vertical wiring portion in a connection region and a flexible board having connection terminals formed at end portions are separately formed. Subsequently, the connection regions of the rigid boards are each machined to form a cut-off portion having a depth larger than the thickness of the flexible board, thereby forming steps. Next, the connection terminals of the flexible board are connected to the vertical wiring portions at the steps.

A flex-rigid wiring board described in PCT International Publication WO2004/093508 includes a rigid board and a flexible board which are bonded with an insulating adhesive interposed to form a unified body. In addition, connection electrode pads of the rigid and flexible boards are electrically and physically connected to each other through with a conductor block and penetrating through the insulating adhesive. In the flex-rigid wiring board having the above structure, the flexible board is disposed on one side of the rigid substrate, a via is formed by laser irradiation, and connection is formed by plating from the flexible board side.

The contents of the above mentioned publications are incorporated herein by reference in their entirety.

SUMMARY OF THE INVENTION

According to one aspect of the present invention, a flex-rigid wiring board has a flexible board including a flexible substrate and a conductor pattern formed over the flexible

substrate, a non-flexible substrate disposed adjacent to the flexible board, an insulating layer including an inorganic material and covering the flexible board and the non-flexible substrate, a conductor pattern formed on the insulating layer, and a plating layer connecting the conductor pattern of the flexible board and the conductor pattern on the insulating layer. The insulating layer is exposing at least one portion of the flexible board.

According to another aspect of the present invention, a flex-rigid wiring board has a flexible board including a flexible substrate and a conductor pattern formed over the flexible substrate, a non-flexible substrate disposed adjacent to the flexible board, an insulating layer including an inorganic material and covering the flexible board and the non-flexible substrate, the insulating layer exposing at least one portion of the flexible board, a conductor pattern formed on the insulating layer, and a via formed in the insulating layer and connecting the conductor pattern on the insulating layer and the conductor pattern of the flexible board.

According to yet another aspect of the present invention, a flex-rigid wiring board includes a flexible board including a flexible substrate and a conductor pattern formed over the flexible substrate, a non-flexible substrate disposed adjacent to the flexible board, an insulating layer including an inorganic material and covering the flexible board and the non-flexible substrate, the insulating layer exposing one or more portions of the flexible board, a conductor pattern formed on the insulating layer, and a via formed in the insulating layer and connecting the conductor pattern on the insulating layer and the conductor pattern of the flexible board. The flexible board further includes a protective layer covering the conductor pattern of the flexible board, and the via formed in the insulating layer includes a plating layer.

According to still another aspect of the present invention, a method of manufacturing a flex-rigid wiring board includes disposing a flexible board including a flexible substrate and a conductor pattern formed over the flexible substrate and a non-flexible substrate adjacent to each other, covering a boundary between the flexible board and the non-flexible substrate with an insulating layer including an inorganic material, providing a conductor pattern on the insulating layer, forming a via hole opening which passes through the insulating layer and reaches the conductor pattern of the flexible board, and plating the via hole opening to form a via connecting the conductor pattern of the flexible board and the conductor pattern on the insulating layer.

BRIEF DESCRIPTION OF THE DRAWINGS

A more complete appreciation of the invention and many of the attendant advantages thereof will be readily obtained as the same becomes better understood by reference to the following detailed description when considered in connection with the accompanying drawings, wherein:

FIGS. 1A and 1B are a side view and a plan view, respectively, of a flex-rigid wiring board according to one embodiment of the present invention;

FIG. 2 is a partly enlarged view of FIG. 1A;

FIG. 3 is a view showing a modification of the flex-rigid wiring board shown in FIG. 2;

FIG. 4 is a side view of a flexible substrate;

FIGS. 5A to 5L are a flowchart illustrating a manufacturing method of a flex-rigid wiring board according to another embodiment of the present invention;

FIGS. 5A', 5G', 5K' and 5L' are views illustrating modified steps of the method of manufacturing a flex-rigid wiring board shown in FIGS. 5A to 5L;

FIGS. 5F", 5G" 5K" and 5L" are views illustrating other modified steps of the method of manufacturing a flex-rigid wiring board shown in FIGS. 5A to 5L;

FIGS. 6A to 6F are enlarged views illustrating the manufacturing method of a flex-rigid wiring board, which is illustrated with reference to FIGS. 5A to 5L;

FIG. 7 is a view showing a modification of the flex-rigid wiring board shown in FIG. 3;

FIG. 8 is a view showing another modification of the flex-rigid wiring board shown in FIG. 3;

FIGS. 9A and 9B are views each showing a modification of the flex-rigid wiring board shown in FIG. 2;

FIGS. 10A and 10B are views each showing a modification of the flex-rigid wiring board shown in FIG. 3;

FIGS. 11A to 11F are views illustrating steps of a manufacturing method of the flex-rigid wiring board shown in FIG. 10A;

FIGS. 12A to 12F are views illustrating steps of a manufacturing method of the flex-rigid wiring board shown in FIG. 10B;

FIGS. 13A and 13B are view each showing a modification of the flex-rigid wiring board shown in FIG. 7;

FIGS. 14A and 14B are views each showing a modification of the flex-rigid wiring board shown in FIG. 8;

FIG. 15 is a view showing an example in which a wiring pattern is fanned out;

FIG. 16 is a view showing an example in which the strength is increased by forming a part of a flexible substrate to have a large width; and

FIG. 17 is a view showing another example in which the strength is increased by forming a part of a flexible substrate to have a large width.

DESCRIPTION OF THE EMBODIMENTS

The embodiments will now be described with reference to the accompanying drawings, wherein like reference numerals designate corresponding or identical elements throughout the various drawings.

As shown in FIGS. 1A and 1B, a flex-rigid wiring board 10 according to one embodiment of the present invention has a first rigid board 11, a second rigid board 12, and a flexible board 13 connecting the rigid boards 11, 12.

On the first and the second rigid boards 11, 12, appropriate circuit patterns are formed. In addition, whenever necessary, for example, electronic elements, such as a semiconductor chip, are connected.

On the flexible board 13, a stripe wire (13a) is formed to connect the circuit patterns of the first rigid board 11 and the second rigid board 12. Hence, the wire (13a) connects the circuit pattern of the rigid board 11 and the circuit pattern of the rigid board 12.

As for the structure of a connection portion of the flexible board 13 with the rigid boards 11, 12, the connection portion between the rigid board 11 and the flexible board 13 is describe in detail by way of example with reference to FIG. 2.

FIG. 2 is an enlarged cross-sectional view of an area represented by reference numeral 2 of FIG. 1A. As shown in the figure, the flexible board 13 has the structure in which a substrate 131, conductive layers 132, 133, insulating films 134, 135, shield layers 136, 137, and cover lays 138, 139 are laminated.

The substrate 131 may be formed of an insulating flexible sheet, such as a polyimide sheet having a thickness of approximately 20 to 50 μm , preferably a thickness of approximately 30 μm .

The conductive layers 132, 133 may be formed on the front surface and the rear surface of the substrate 131, respectively, so that the stripe wire pattern (13a) is formed. The conductive layers 132, 133 may be each formed, for example, of a copper pattern having a thickness of approximately 5 to 15 μm .

The insulating films 134, 135 may be each formed, for example, of a polyimide film having a thickness of approximately 5 to 15 μm and insulate the conductive layers 132, 133 from the outside.

The shield layers 136, 137 (also referred as "electromagnetic shield layers") may be formed of conductive layers, such as cured films made from a silver paste, to shield electromagnetic noises to the conductive layers 132, 133 from the outside and to shield electromagnetic noises to the outside from the conductive layers 132, 133.

The cover lays 138, 139 may be each formed of an insulating film made, for example, of a polyimide film having a thickness of approximately 5 to 15 μm , and insulate and protect the whole flexible board 13 from the outside.

On the other hand, the rigid board 11 is formed of a first insulating layer 111, a non-flexible substrate 112, a second insulating layer 113, a first upper insulating layer 114, and a second upper insulating layer 115, which are laminated to each other.

The non-flexible substrate 112 imparts rigidity to the rigid board 11 and may be formed of a non-flexible insulating material such as a glass epoxy resin. The non-flexible substrate 112 is disposed apart from the flexible board 13 in a horizontal direction. The non-flexible substrate 112 is formed to have a thickness approximately equivalent to that of the flexible board 13, for example, approximately 50 to 150 μm , preferably approximately 100 μm .

The first and second insulating layers 111, 113 are formed by curing prepregs. The first and the second insulating layers 111, 113 each have a thickness of approximately 50 to 100 μm , preferably approximately 50 μm .

The above prepregs are preferably formed of a resin having low flow properties. The prepregs as described above may be formed by impregnating glass clothes (111a, 113a), each of which is an inorganic material, with an epoxy resin, followed by thermal curing of the resin to increase the curing degree thereof beforehand. Furthermore, inorganic materials (111b, 113b), such as silica filler or glass filler, may be added to the resin.

In addition, the prepregs described above can also be formed by impregnating glass clothes with a resin having a high viscosity, impregnating glass clothes with a resin containing inorganic filler, for example, silica filler, or by decreasing the amount of a resin to be used for impregnation of glass clothes.

The first and the second insulating layers 111, 113 cover the front and the rear surface sides of the non-flexible substrate 112 and the flexible board 13 and partly expose the flexible board 13. In addition, the first and the second insulating layers 111, 113 are overlapped together with the cover lays 138, 139 which are at the surfaces of the flexible board 13.

The non-flexible substrate 112 and the first and second insulating layers 111, 113 form a core of the rigid board 11 to support the rigid board 11 and also support and fix the flexible board 13 by sandwiching one end portion thereof.

The non-flexible substrate 112, the flexible board 13, and the first and second insulating layers 111, 113 form a space, and a resin 125 is filled in this space. The resin 125 is, for example, a resin seeping from low-flow prepregs forming the first and second insulating layers 111, 113 during the manufacturing and is integrally cured together with the first and

second insulating layers **111**, **113**. Hence, the resin **125** also includes an inorganic material.

Furthermore, in a part of the second insulating layer **113** corresponding to a connection pad (**13b**) of the wire **133** of the flexible board **13**, a via opening (via hole or contact hole) **116** is formed.

In the flexible board **13**, at a part corresponding to the via opening **116** (part at which the connection pad (**13b**) of the conductive layer (**13a**) is formed), the shield layer **137** and the cover lay **139** of the flexible board **13** are removed. The via opening **116** penetrates the insulating film **135** of the flexible board **13** and exposes the connection pad (**13b**) of the conductive layer **133**.

On the inner surface of the via opening **116**, a conductive layer **117** (may also be referred as "vias," "via hole conductor structure," or "via contact") made by copper plating or the like is formed. The conductive layer **117** (may also be referred as a via, a via hole conductor structure, or a through hole conductor structure) is connected to the connection pad (**13b**) of the conductor layer **133** of the flexible board **13** by plating. In addition, the via opening **116** is filled with a resin, such as a resin containing an inorganic material.

On the second insulating layer **113**, an extending pattern **118** connected to the conductive layer **117** is formed. The extending pattern **118** may be formed of a copper plating layer or the like.

In addition, at a front end of the second insulating layer **113**, that is, at a position extending over a boundary between the flexible board **13** and the non-flexible substrate **112**, a copper pattern **124** isolated from the others is disposed. Hence, heat generated in the rigid board **11** is effectively dissipated.

The first upper insulating layer **114** is disposed so as to be laminated on the second insulating layer **113**. The first upper insulating layer **114** may be formed by curing a material containing an inorganic material, such as silica filler, glass filler, carbon fibers, or ceramic fibers, e.g., prepregs having glass clothes impregnated with a resin. By the structure as described above, dropping impact resistance is improved.

In a manufacturing process of this flex-rigid wiring board, the via opening **116** is filled with a resin containing an inorganic material, which is supplied from the prepregs.

In addition, on the first upper insulating layer **114**, the second upper insulating layer **115** is disposed. The second upper insulating layer **115** may be formed by curing prepregs made of glass clothes impregnated with a resin containing an inorganic material such as silica filler or glass filler.

In the first upper insulating layer **114** disposed on the second insulating layer **113**, a via opening (first upper via opening) **119** connected to the extending pattern **118** is formed. The via opening **119** is filled with a conductor **120** (may also be referred to as "upper vias," "upper via hole conductor structure," or "upper via contact") made of copper or the like. In addition, in the second upper insulating layer **115** laminated on the first upper insulating layer **114**, a via opening (second upper via opening) **121** connected to the via opening **119** is formed. The via opening **121** is filled with a conductor **122** (also referred to as "vias," "via hole conductor structure," or "via contact"). That is, by vias **120**, **122** (may also be referred as "upper via"), a filled buildup via is formed.

On the second upper insulating layer **115**, a conductive pattern (circuit pattern) **123** is appropriately formed. The via **120** is also appropriately connected to the above conductive pattern **123**.

In addition, the structure of a connection portion between the rigid board **12** and the flexible board **13** is similar to that of between the rigid board **11** and the flexible board **13**.

In the flex-rigid wiring board **10** having the above structure, the end portion of the flexible board **13** is sandwiched by the first and second insulating layers **111**, **113** forming the rigid board **11** and is overlapped.

Furthermore, the connection pad (**13b**) of the conductive layer **133** of the flexible board **13** and the conductive pattern **123** of the rigid board **11** are connected to each other via the copper plating layer **117** (may also be referred as "via," "via hole conductor structure," or "through-hole conductor structure") formed in the via opening **116** which is formed in the second insulating layer **113** and the insulating film **135**.

Hence, when the flexible board **13** is bent, a stress applied thereto is not transmitted to the connection portion (via opening **116** and the layer **117**) of the rigid board **11**. As a result, a stress applied to the connection portion between the rigid board **11** and the flexible board **13** is small, and hence the reliability is high.

In particular, the insulating layers **111**, **113** contain the inorganic materials (**111a**, **111b**, **113a**, **113b**), such as glass clothes, silica filler, glass filler, carbon fibers, and ceramic fibers. The inorganic materials mentioned above have high rigidity as compared to that of a resin which is an organic material. Hence, compared to the case in which the insulating layers **111**, **113** are entirely formed of a resin, the rigidity of the insulating layers **111**, **113** is high. Accordingly, even when the flexible board **13** is bent, the core is not substantially deformed. As a result, a stress is not likely to be transmitted to the connection portion between the rigid board **11** and the flexible board **13**. In addition, as the inorganic material, particularly, glass cloth is preferable. Compared to other inorganic materials, the glass cloth can most improve the rigidity of the insulating layers **111**, **113**. Accordingly, in the case in which the insulating layers **111**, **113** contain the glass clothes (**111a**, **113b**), even when the flexible board **13** is bent, the core is not deformed, and hence, a stress is not likely to be transmitted to the connection portion between the flexible board **13** and the rigid board **11**.

In addition, the conductive layer **133** of the flexible board **13** and the layer **117** inside the via opening **116** are connected to each other by plating. Hence, the reliability of the connection portion is high.

Furthermore, in the via opening **116**, the resin of the upper insulating layer **114** is filled. The via opening **116** is fixed and supported by the resin therein, and the connection reliability between the via **117** and the conductive layer **133** is improved.

In addition, the end surfaces of the insulating layers **113**, **111** at the flexible board side protrude further than the end surface of the upper insulating layer **114** at the flexible board side. Hence, when the flexible board **13** is bent, a stress applied to the flexible board **13** is not transmitted to the connection portion (the via opening **116** and the via **117**) of the rigid board **11**. As a result, a stress applied to the connection portion between the rigid board **11** and the flexible board **13** is small, and hence the reliability is high.

In addition, the structure is formed so that the core portion of the rigid board **11** restrains expansion and contraction of the flexible board **13**, which tends to expand and contract, in a horizontal direction. Hence, bending reliability and heat-resistance reliability are high. Since a flexible substrate portion of the flexible board **13** is exposed between the rigid boards **11**, **12**, compared to the case in which the entire structure is covered with an insulating resin or the like, when bending is performed, a stress applied to wires or the like is small.

In addition, the flex-rigid wiring board **10** has the structure in which the end portion of the flexible board **13** is sand-

wiched by the first and second insulating layers **111**, **113** of the rigid board **11**. Hence, the influence of change in dimension of the flexible board **13** is small, and as a result, for example, the deviation in placement position of a connection land (via **117**) of the rigid board **11** can be decreased. Accordingly, the diameter of the via opening **116** can also be designed to be small.

In addition, the insulating layers **111**, **113** contain inorganic materials (**111a**, **111b**, **113a**, **113b**), such as glass clothes, silica filler, glass filler, carbon fibers, and ceramic fibers. Compared to a resin which is an organic material, the inorganic materials mentioned above have a small coefficient of thermal expansion and make small expansion and contraction. Hence, compared to the case in which the insulating layers **111**, **113** are entirely formed of a resin, the positional deviation of the connection land is small, and the connection land can be formed to be small.

In addition, in the rigid boards **11**, **12**, the flexible board **13** is not disposed. Hence, reliability approximately equivalent to that of a conventional rigid board can be maintained. In addition, resistance against a plating solution is high, and hence a general plating solution can be used. Since a flexible material is also not used for the rigid portion, heat resistance equivalent to that of a usual rigid portion can be maintained.

Furthermore, since the flexible substrate **13** is partly used and is effectively disposed, the manufacturing cost can be reduced.

The upper insulating layers **114**, **115** may be formed of usual prepregs. The usual prepregs have good conformity with interlayer patterns when being provided therebetween. Hence, insulation degradation caused, for example, by generation of voids can be avoided. In addition, a fine pattern, for example, (L/S=60/60, 50/50 μm) can be realized. Furthermore, material control can be performed in a restricted manner.

In addition, as the upper insulating layers **114**, **115**, a usual interlayer material (prepregs) may be used. Hence, in a manufacturing process, IVH (Interstitial Via Hole) including the via opening **116** can be filled with a resin forming the upper insulating layers **114**, **115**. As a result, a resin exclusively for filling the via is not required.

Since a glass epoxy substrate is used for the core portion of the rigid board **11**, dropping impact resistance is improved.

In this embodiment, in order to facilitate the understanding, only on the upper surfaces of the rigid boards **11**, **12**, the conductive patterns are formed. However, the present invention is not limited to such an example. For example, as shown in FIG. 3, conductive patterns may be disposed at the lower sides of the rigid boards **11**, **12**.

In the structure shown in FIG. 3, a via opening **141** is formed in the first insulating layer **111** and the insulating film **134** of the flexible board **13**. In the via opening **141**, a conductive pattern **142** is formed and is connected to an extending pattern **143** formed on the first insulating layer **111**. The conductive pattern **142** and the extending pattern **143** are formed by patterning a copper plating layer.

On the first insulating layer **111**, third and fourth upper insulating layers **144**, **145**, which contain an inorganic material, are laminated. In the third and fourth upper insulating layers **144**, **145**, via openings **146**, **147** are formed. The via openings **146**, **147** are filled with conductors **148**, **149** (also referred to as "vias," "via hole conductor structure," or "via contact"). On the upper insulating layer **145**, a conductive pattern **150** is formed.

Next, a method for manufacturing the flex-rigid wiring board **10** having the above structure will be described.

First, a method for manufacturing the flexible board **13** is described according to one embodiment of the present invention.

Copper films are formed on two surfaces of the polyimide substrate **131** processed into a predetermined size. Next, by patterning the copper films, the conductive layers **132**, **133** having the wire patterns (**13a**) and the connection pads (**13b**) are formed.

On the polyimide substrate **131** and the two conductive layers **132**, **133**, the insulating films **134**, **135** each made of a polyimide layer or the like are formed. In addition, a silver paste is coated on the flexible board **13** other than the end portion thereof and is then cured, so that the shield layers **136**, **137** are formed.

Subsequently, the cover lays **138**, **139** are formed so as to cover the shield layers **136**, **137** located at the front surface and the rear surface sides, respectively.

As described above, the flexible board **13** having the structure shown in FIG. 4 is formed. In this structure, the shield layers **136**, **137** and the cover lays **138**, **139** are formed at places other than those for the connection pads (**13b**).

Next, a method for bonding the rigid boards **11**, **12** to the flexible board **13** is described.

First, as shown in FIG. 5A, the first insulating layer **111**, the non-flexible substrate **112**, and the second insulating layer **113**, which form the core of the rigid board **11**, are aligned. In this case, the first and the second insulating layers **111**, **113** are formed, for example, of low flow prepregs containing inorganic materials (**111a**, **111b**, **113a**, **113b**), and having a thickness of approximately 20 to 50 μm , and the non-flexible substrate **112** is formed, for example, of a glass epoxy substrate having a thickness of approximately 100 μm . The low flow prepregs as described above are formed, for example, by impregnating the glass clothes (**111a**, **113a**), which are an inorganic material, with an epoxy resin added with the inorganic materials (**111b**, **113b**), such as silica filler or glass filler, or by thermally curing of an epoxy resin added with the inorganic materials (**111b**, **113b**), such as silica filler or glass filler, beforehand to increase the curing degree.

In this embodiment, as shown in FIG. 2, the thickness of the non-flexible substrate **112** and the thickness of the flexible board **13** are preferably approximately equivalent to each other. According to the structure described above, in a space present between the non-flexible substrate **112** and the cover lay **139**, the resin **125** containing the inorganic materials (**111b**, **113b**) can be filled, and the flexible board **13** and the non-flexible substrate **112** can be securely adhered to each other.

In addition, since the resin **125** filled in the space is integrally cured with the insulating layer **113**, the periphery of the via opening **116** is fixed by the resin **125**, and hence the connection reliability between the via **117** and the conductive layer **133** is improved.

In the same manner as described above, a non-flexible substrate and first and second insulating layers, which form a core of the rigid board **12**, are aligned.

Furthermore, one end portion of the flexible board **13** is sandwiched between the first and second insulating layers **111**, **113** of the rigid board **11** for positioning, and the other end portion is disposed between the non-flexible substrate and the first and second insulating layers of the rigid board **12**. Furthermore, conductive films **161**, **162** (also referred as "copper foils") made of copper or the like are disposed on the top and the bottom of a structure thus formed. A separator may be provided on the flexible board **13** before conductor films **161**, **162** is disposed on and below these layers.

Next, as shown in FIG. 5B, the above structure is pressed under pressure. In this step, as shown by an enlarged view of FIG. 6A, the resin 125 containing the inorganic materials (111b, 113b), which is extruded from the prepregs forming the first and second insulating layers 111, 113, fills the space between the non-flexible substrate 112 and the flexible board 13. As described above, since the space is filled with the resin 125, the flexible board 13 and the non-flexible substrate 112 can be securely adhered to each other.

The above pressure pressing may be performed, for example, by a hydraulic press apparatus under conditions in which the temperature, the pressure, and the press time are set to approximately 200° C., 40 kgf, and 3 hours, respectively.

Subsequently, for example, by heating the whole structure, the prepregs forming the first and second insulating layers 111, 113 and the resin 125 are cured and are integrated together. In this step, the cover lays 138, 139 of the flexible board 13 and the resin of the first and second insulating layers 111, 113 are overlapped. When the resin of the insulating layers 111, 113 is overlapped, the periphery of the via opening 116 is fixed by the resin, and the connection reliability between the via 117 and the conductive layer 133 is improved.

Next, for example, by irradiation of CO₂ laser from a CO₂ laser processing device, IVH (Interstitial Via Hole) 163 is formed as required as shown in FIG. 5C. In this case, as shown by an enlarged view of FIG. 6B, the via openings 116, 141 are also formed to connect the wire layers 132, 133 of the flexible board 13 to the rigid boards 11, 12.

Subsequently, as shown in FIG. 5D, the entire surface of the structure is processed by copper plating. This copper plating and the existing copper patterns 161, 162 are integrated together, and hence a copper film 171 is formed over the entire surface of the board. As shown in FIG. 6C, the copper film 171 is also formed inside the via openings 116, 141. In this step, the flexible board 13 is covered with the copper foils 161, 162 and hence is not directly brought into contact with a plating solution. Hence, the flexible board 13 is not damaged by a plating solution.

Subsequently, as shown in FIG. 5E, the copper film 171 located at the board surface is patterned. By this step, the vias 117, 142 connected to the conductive layers 132, 133 of the flexible board 13 and the extending patterns 118, 143 are formed. In this step, as shown in FIG. 6D, the copper foil 171 is allowed to remain at the edge portions of the first and second insulating layers 111, 113.

Next, as shown in FIG. 5F, on the top and bottom of a resulting structure, the first and third upper insulating layers 114, 144 may be disposed. The first and third upper insulating layers 114, 144 may be formed, for example, of prepregs made of glass clothes, which are an inorganic material, impregnated with a resin containing an inorganic material such as silica filler or glass filler. The via openings 116, 141 are filled with the resin forming the prepregs.

Subsequently, for example, by curing the resin of the prepregs and inside the via openings by heating, the first and third upper insulating layers 114, 144 are solidified. Then, via openings 119, 144 are formed in the first and third upper insulating layers 114, 144, and by copper plating or the like, the via openings 119, 144 are filled with a conductive material. Alternatively, a conductive paste (for example, a thermosetting resin containing conductive particles) may be filled in the via openings 119, 114 by screen printing or the like, followed by curing.

Next, as shown in FIG. 5G, on the top and bottom of the entire board, the second and fourth upper insulating layers 115, 145 are disposed. The second and fourth upper insulating

layers 115, 145 may be formed, for example, of usual prepregs made of glass clothes, which are an inorganic material, impregnated with a resin containing an inorganic material such as silica filler or glass filler. Before the second and fourth upper insulating layers 115, 145 are formed, a separator may be disposed in an opening formed in the first and third upper insulating layers 114, 144.

Subsequently, for example, by curing the resin of the prepregs by heating, the second and fourth upper insulating layers 115, 145 are solidified.

Furthermore, via openings 121, 147 are formed in the second and fourth upper insulating layers 115, 145, and by copper plating or the like, the via openings 121, 147 are filled with a conductive material. Alternatively, a conductive paste (for example, a thermosetting resin containing conductive particles) may be filled in the via openings 121, 147 by screen printing or the like, followed by curing. When the same conductive paste material is filled in the via openings 121, 147, the connection reliability is improved when a thermal stress is applied to the vias 122, 149 (also referred as "upper vias").

Furthermore, as required, as shown in FIG. 5H, resin provided with copper foil sheets (Resin Copper Film; RCF) 172, 173 may be disposed as the outermost layers of the board, followed by pressing.

Subsequently, the entire structure is heated, so that the resin is cured.

Then, as shown in FIG. 5I, via openings 174, 175 are formed in the RCFs 172, 173. Next, by copper plating or the like, the via openings 174, 175 are filled with a conductive material. In addition, as required, the copper foil located at the surface is patterned to form a conductive pattern.

Next, as shown in FIGS. 5J and 6E, bonding portions of the flexible board 13 with the rigid boards 11, 12 are irradiated with laser beam 158, such as CO₂ laser, generated from a laser processing device, so that the upper insulating layers 114, 115, 144, 145, and the resin with copper foil sheets (RCFs) 172, 173 are cut, using the copper foil 171 formed on the edge portions of the cores of the rigid boards 11, 12 as a stopper. In this step, the energy or the irradiation time is adjusted so as to cut the copper foil 171 used as the stopper to a certain extent.

Accordingly, as shown in FIG. 5H, a structure 181 on the flexible board 13 is separated from the others.

Next, as shown in FIG. 5L, the structure 181 is removed by peeling off from the flexible board 13. The copper foils 161, 162 (see FIG. 5B), from which the remaining copper foil 171 is formed, are simply pressed on the cover lays 138, 139 and are not fixedly bonded thereto. In the same manner as described above, the copper foil 171 is also not fixedly bonded to the flexible board 13. Hence, when the structure 181 is removed, the copper foil 171 is also removed.

As described above, parts of the copper foil 171, which are not covered by other components, are removed. Hence, at the edge portions of the first and second insulating layers 111, 113, the copper foils 124, 151, which are covered with the prepregs 113, 144, remain.

As described above, the end portions of the flexible board 13 are held by the core portions (the first and second insulating layers 111, 113) of the rigid boards 11, 12, and in addition, lands of the rigid boards 11, 12 and connection pads of the flexible board 13 are connected to each other by plating, thereby forming the flex-rigid wiring board 10.

According to the structure described above, plating on polyimide of the flexible board 13 is not required, and hence the connection reliability is ensured.

11

In addition, RCF can be used as the outermost layers of the rigid boards **11**, **12**. Hence, similar reliability and dropping impact resistance as those of a conventional rigid board is ensured.

In this manufacturing method, in order to form the core layers of the rigid boards **11**, **13**, prepregs made of a resin having low flow properties are used. However, for other than the core layers, usual prepregs may be used, IVH filling is not required, and voids are also not liable to be generated.

Furthermore, since only the bending portion is formed of the flexible board, the stability is improved.

Since openings are formed in multiple layers by laser processing after the external layers are formed, the manufacturing cost is reduced.

In addition, since openings are formed in multiple layers by laser processing after the external layers are formed, the accuracy of the opening in the flexible board is high.

In addition, since the core portions of the rigid boards **11**, **12** are formed of a glass epoxy substrate, the dropping impact resistance is improved.

A method for manufacturing the flex-rigid wiring board **10** is not limited to those steps referred in FIGS. **5A** to **6L**. For example, referring to FIG. **5A'**, a separator **291** may be provided in a gap (**113a**) formed in the second insulating layer **113**. The separator **291** may be, for example, a cured prepreg or a polyimide film. Also, an adhesive may be provided between the separator **291** and the copper film **171**.

In such a case, through the steps shown in FIGS. **5B** to **5F**, the copper film **171** and the upper insulating layers **114**, **115** may be formed over the separator **291** as shown in FIG. **5G'**. Subsequently, through the steps shown in FIGS. **5H** to **5L**, the copper film sheet with resin (Resin Copper Film or RCF) **173** is provided over the upper insulating layer **115**, and the via opening **174** is formed and filled with conductive material. Then, the boundary between the upper insulating layer **113** and the separator **291** is cut by the laser beam **158**, using the copper film **171** as a stopper. At this time, the energy or irradiation time of the laser beam **158** may be adjusted such that the copper film **171** is cut appropriately to some extent. As such, a structure **181** over the flexible board **13** is separated as shown in FIG. **5K'**. Then, the structure **181** may be torn off and removed from the flexible board **13** as shown in FIG. **5L'**. The separator **291** makes easier to tear off and remove the structure **181** from the flexible board **13**. Also, the separator **291** supports the copper film **171** and prevents a plating solution from seeping into the gap (**113a**) between the flexible board **13** and the copper film **162** and the copper film **171** from being torn.

Also, referring to FIGS. **5F''**, **5G''**, **5K''** and **5L''**, another method for manufacturing the flex-rigid wiring board **10** is described below as a modification from the steps shown in FIGS. **5A** to **6L**. In this modification, after the separator **291** is provided, the steps described in FIGS. **5B** through **5F** are carried out. Then, using a laser, a cut line **292** may be formed in a portion of the upper insulating layer **114** above the separator **291** as shown in FIG. **5F''**. Thereafter, the upper insulating layer **115** is provided over the upper insulating layer **114**. However, in the place of a portion of the upper insulating layer **115**, a separator **293** having one edge portion reaching over the cut line **292** is provided as shown in FIG. **5G''**. Subsequently, the resin bearing copper film sheet **173** is provided over the upper insulating layer and the separator **293** by carrying out the steps described in FIGS. **5H** and **5I**, a via opening is formed in the upper insulating layer **115**, and copper plating is conducted. Then, using a laser, cut lines **294**, **295** are formed over one edge portion of the separator **291** and over the other edge portion of the separator **293** as shown in

12

FIG. **5K''**. Finally, as shown in FIG. **5L''**, a structure **296** defined by the cut line **294**, the separator **291**, the cut line **292**, the separator **293** and the cut line **295** is removed. With such a structure, a portion or portions which do not contribute to the formation of circuitry may be removed and the volume of a wiring board may be reduced.

In the above, the modifications concerning the manufacturing steps related to the rigid board **12** are described. However, such modifications may be applied to the manufacturing steps of the rigid board **11** or both of the rigid boards **11**, **12**. Also, in the examples described above, the modifications describe the manufacturing steps concerning the upper portions of the flex-rigid wiring board **10**. However, such modifications may be applied to the lower portions of the flex-rigid wiring board **10** or the flex-rigid wiring board **10** as a whole.

The flex-rigid wiring board **10** according to one embodiment of the present invention is described above; however, the present invention is not limited to such an example.

For example, the materials, sizes, number of layers described above, and the like may be modified appropriately.

For example, in the above embodiment, the resin **125** and the resin forming the first and second insulating layers **111**, **113**, the upper insulating layers **114**, **115**, **144**, **145** are described as a resin containing an inorganic material. However, the present invention is not limited to that described above, and for example, as a resin forming the upper insulating layers **114**, **115**, **144**, **145**, a resin containing no inorganic materials may be used.

Furthermore, when the first and second insulating layers **111**, **113** have the glass clothes (**111a**, **113a**), the resin thereof may not contain an inorganic material.

The materials, forms (clothes, filler, particles, and the like), addition amounts, and content ratios of the inorganic materials contained in the individual components may be appropriately selected and determined in accordance with rigidity, strength, coefficient of thermal expansion, and the like required for the components.

In addition, as shown in an example of FIG. **7**, the via openings **116**, **141** may be filled with a conductive material such as a plating metal. When the via openings **116**, **141** are not fully filled with a resin, voids may be present inside the via openings **116**, **141**. In this case, when heat is applied to the flex-rigid wiring board **10**, the connection reliability of the vias may be degraded in some cases due to expansion of the voids. As shown in FIG. **7**, when the via openings **116**, **141** are filled with a plating metal, the connection reliability of the vias **117**, **142** is improved when heat is applied thereto.

As is the case described above, conductive patterns (circuit patterns) **191**, **192** may be formed on the non-flexible substrate **112** to be connected to appropriate portions.

In addition, conductive patterns (circuit patterns) **193**, **194** may be formed on the upper insulating layers **114**, **144** to be connected to appropriate portions.

The conductive patterns **191**, **143**, **193**, **150** are connected to each other through the vias **148**, **149** and other appropriately formed vias. In the same manner as described above, the conductive patterns **192**, **118**, **194**, **123** are connected to each other through the vias **120**, **122** and other vias. Furthermore, through the via formed in the via opening **163**, the conductive patterns **123**, **150** are also connected to each other.

In this embodiment, the first and second insulating layers **111**, **113**, which sandwich the end portion of the flexible board **13**, may be formed from RCF. In addition, the first and third upper insulating layers **114**, **144** and the second and fourth upper insulating layers **115**, **145** may be formed of RCF. Such a structure allows the number of manufacturing steps to be reduced.

13

In this embodiment, the thickness of the flexible board **13** is set to be approximately equivalent to that of the non-flexible substrate **112**; however, the present invention is not limited to such an example. For example, as shown in FIG. **8**, the thickness of the flexible board **13** may be formed smaller than that of the non-flexible substrate **112**. In this case, a space formed between the flexible board **13**, the non-flexible substrate **112**, and the first and second insulating layers **111**, **113** is filled with an appropriate resin, such as a resin which seeps from the insulating layers **111**, **113** or a resin which is provided beforehand in manufacturing for height adjustment. Since the space is filled with the resin **125**, the flexible board **13** and the non-flexible substrate **112** are securely adhered to each other.

In addition, those resins are integrally cured and solidified together by heating during manufacturing. As described above, since the resins of the insulating layers **111**, **113** are overlapped, and the resin **125** is further integrally cured and solidified, the peripheries of the via openings **116**, **141** are fixed by the resins, the connection reliability of the vias **117**, **142** with the conductive layer **133**, **132** are improved.

In the embodiment described above, the first insulating layer **111** contains the glass clothes (**111a**) and the inorganic material (**111b**), and the second insulating layer **113** contains the glass clothes (**113a**) and the inorganic material (**113b**). However, as for the flex-rigid wiring board **10** shown in FIG. **2**, for example, the structure may be formed as shown in FIG. **9A** in which the first and second insulating layers **111**, **113** contain the glass clothes (**111a**, **113a**) and contain no inorganic materials (**111b**, **113b**). In addition, as shown in FIG. **9B**, a structure may also be formed such that the first and second insulating layers **111**, **113** contain the inorganic materials (**111b**, **113b**) but contain no glass clothes (**111a**, **113a**).

Furthermore, as for the flex-rigid wiring board **10** shown in FIG. **3**, for example, as shown in FIG. **10A**, the first and second insulating layers **111**, **113** may contain the glass clothes (**111a**, **113a**), respectively, but may not contain the inorganic materials (**111b**, **113b**). In addition, as shown in FIG. **10B**, the first and second insulating layers **111**, **113** may contain the inorganic materials (**111b**, **113b**), respectively, but may not contain the glass clothes (**111a**, **113a**).

The flex-rigid wiring board **10** having the structure shown in FIG. **10A** is manufactured, for example, by the steps shown in FIGS. **5A** to **5L** and FIGS. **11A** to **11F**. This manufacturing method is similar to that described with reference to FIGS. **5A** to **5L** and FIGS. **6A** to **6F** except that as the first and second insulating layers **111**, **113**, insulating layers (prepregs) which contain the glass clothes (**111a**, **113a**) but contain no inorganic materials (**111b**, **113b**) are used.

In addition, the flex-rigid wiring board **10** having the structure shown in FIG. **10B** is manufactured, for example, by the steps shown in FIGS. **5A** to **5L** and FIGS. **12A** to **12F**. This manufacturing method is similar to that described with reference to FIGS. **5A** to **5L** and FIGS. **6A** to **6F** except that as the first and second insulating layers **111**, **113**, insulating layers (prepregs) which contain no glass clothes (**111a**, **113a**) but contain the inorganic materials (**111b**, **113b**) are used.

Furthermore, the flex-rigid wiring board **10** shown in FIG. **7** may be formed, for example, of the first and second insulating layers **111**, **113** which contain the glass clothes (**111a**, **113a**) but contain no inorganic materials (**111b**, **113b**). In addition, as shown in FIG. **13B**, the first and second insulating layers **111**, **113** may contain the inorganic materials (**111b**, **113b**), respectively, but may not contain the glass clothes (**111a**, **113a**).

Furthermore, the flex-rigid wiring board **10** shown in FIG. **8** may be formed, for example, of the first and second insu-

14

lating layers **111**, **113** which contain the glass clothes (**111a**, **113a**) but contain no inorganic materials (**111b**, **113b**), as shown in FIG. **14A**. In addition, as shown in FIG. **14B**, the first and second insulating layers **111**, **113** may contain the inorganic materials (**111b**, **113b**), respectively, but may not contain the glass clothes (**111a**, **113a**).

In the embodiments described above, as the inorganic materials contained in the insulating layers **111**, **113**, the glass clothes (**111a**, **113a**), and silica filler or the glass filler (**111b**, **113b**) are described by way of example. The insulating layers **111**, **113** may contain an inorganic material other than those described above. For example, the insulating layers **111**, **113** may contain silica particles, glass particles, carbon fibers, ceramic fibers, and the like.

Furthermore, the upper insulating layers **114**, **115**, **144**, **145** also preferably contain inorganic materials such as glass clothes, silica filler, glass filler, and the like.

In addition, the wire patterns formed on the rigid boards **11**, **12** and the flexible board **13** are not limited to those shown in FIG. **1**, and as shown in FIG. **17**, for example, a wire pattern may be formed so as to be fanned out from the flexible board **13** toward the rigid boards **11**, **13**. That is, the pitch of the connection portion (**13b**) may be set larger than the pitch of the wire (**13a**) of the flexible board **13**. Accordingly, a larger number of wires may be disposed on the flexible board **13**, and as a result, a flex-rigid wiring board having a high wire density can be formed.

In addition, in order to increase the strength of boundary portions between the flexible board **13** and the rigid boards **11**, **12**, as shown in FIGS. **18** and **19**, for example, the flexible board **13** may be formed to have a partly larger width. Accordingly, the bonding areas of the flexible board **13** and the rigid boards **11**, **12** are increased, and as a result, the connection reliability of the vias is improved.

For example, in the example shown in FIG. **18**, the end portion of the flexible board **13** is enlarged, so that the areas of parts to be fixed to the rigid boards **11**, **12** are increased. Accordingly, the strength of the end portions of the flexible board **13** is increased, and hence the bending resistance is improved.

In addition, in the example shown in FIG. **19**, protrusions are formed at positions in which the flexible board **13** is bent repeatedly (for example, positions which correspond to the end portions of the rigid boards **11**, **12**), so that the strength at the positions in which bending is repeatedly performed is increased.

Obviously, numerous modifications and variations of the present invention are possible in light of the above teachings. It is therefore to be understood that within the scope of the appended claims, the invention may be practiced otherwise than as specifically described herein.

What is claimed is:

1. A method for manufacturing a flex-rigid wiring board, comprising:
 - positioning a flexible board and a non-flexible substrate adjacent to each other;
 - forming a metal layer over the flexible board such that the metal layer is configured to stop laser irradiation from reaching into the flexible board;
 - forming an insulating layer such that the insulating layer covers the metal layer, the flexible board and the non-flexible substrate;
 - irradiating laser upon the insulating layer such that the metal layer and a portion of the insulating layer covering the metal layer are cut; and

15

removing the metal layer and the portion of the insulating layer covering the metal layer from the flexible board such that at least a portion of the flexible board is exposed,

wherein the flexible board and the non-flexible substrate are separate structures in the positioning, and the flexible board has a flexible substrate and a conductor pattern formed over the flexible substrate.

2. The method for manufacturing a flex-rigid wiring board according to claim 1, further comprising forming a separator layer over the flexible board, wherein the separator layer is formed between the flexible board and the metal layer.

3. The method for manufacturing a flex-rigid wiring board according to claim 1, further comprising:

forming a conductor layer over the insulating layer; and forming an opening through the conductor layer.

4. The method for manufacturing a flex-rigid wiring board according to claim 1, further comprising:

forming a conductor layer over the insulating layer; and forming an opening through the conductor layer prior to the irradiating of laser.

5. The method for manufacturing a flex-rigid wiring board according to claim 1, further comprising forming a resin layer covering a boundary between the flexible board and the non-flexible substrate prior to the forming of the metal layer, wherein the forming of the resin layer includes forming the resin layer including an inorganic material.

6. The method for manufacturing a flex-rigid wiring board according to claim 1, further comprising:

forming a resin layer covering a boundary between the flexible board and the non-flexible substrate prior to the forming of the metal layer;

forming a via hole opening which passes through the resin layer; and

plating the via hole opening such that a via conductor passing through the resin layer is formed.

7. The method for manufacturing a flex-rigid wiring board according to claim 1, further comprising:

forming a resin layer covering a boundary between the flexible board and the non-flexible substrate prior to the forming of the metal layer;

forming a via hole opening which passes through the resin layer; and

plating the via hole opening such that a via conductor passing through the resin layer is formed,

wherein the forming of the via hole opening comprises forming the via hole opening reaching the conductor pattern of the flexible board, and the plating of the via hole opening comprises forming the via conductor connecting to the conductor pattern of the flexible board.

8. The method for manufacturing a flex-rigid wiring board according to claim 1, further comprising forming a resin layer covering a boundary between the flexible board and the non-flexible substrate prior to the forming of the metal layer, wherein the forming of the resin layer comprises forming the resin layer including an inorganic material, and filling a space formed between the non-flexible substrate and the flexible board with a portion of the resin derived from the resin layer.

9. The method for manufacturing a flex-rigid wiring board according to claim 1, further comprising forming a resin layer covering a boundary between the flexible board and the non-flexible substrate prior to the forming of the metal layer, wherein the forming of the resin layer includes filling a space formed between the non-flexible substrate and the flexible board with a portion of the resin derived from the resin layer.

10. The method for manufacturing a flex-rigid wiring board according to claim 1, further comprising forming a

16

resin layer covering a boundary between the flexible board and the non-flexible substrate prior to the forming of the metal layer, wherein the forming of the resin layer comprises forming the resin layer including an inorganic material, filling a space formed between the non-flexible substrate and the flexible board with a portion of the resin derived from the resin layer, and integrally curing the portion of the resin filling the space with the resin layer.

11. The method for manufacturing a flex-rigid wiring board according to claim 1, further comprising:

forming a resin layer covering a boundary between the flexible board and the non-flexible substrate prior to the forming of the metal layer;

forming a via hole opening which passes through the resin layer; and

plating the via hole opening such that a via conductor passing through the resin layer is formed,

wherein the plating of the via hole opening includes plating a plating metal such that the plating metal fills and closes the via hole opening.

12. The method for manufacturing a flex-rigid wiring board according to claim 1, further comprising:

forming a resin layer covering a boundary between the flexible board and the non-flexible substrate prior to the forming of the metal layer; and

forming a second resin layer over the flexible board and the non-flexible substrate such that the second resin layer covers the boundary between the flexible board and the non-flexible substrate from an opposite side of the flexible board and the non-flexible substrate with respect to the resin layer.

13. The method for manufacturing a flex-rigid wiring board according to claim 1, wherein the forming of the metal layer comprises disposing a metal foil forming the metal layer on the flexible substrate.

14. The method for manufacturing a flex-rigid wiring board according to claim 1, wherein the removing of the portion of the insulating layer comprises removing the portion of the insulating layer together with a portion of the metal layer underneath the portion of the insulating layer.

15. The method for manufacturing a flex-rigid wiring board, according to claim 1, further comprising forming a resin layer covering a boundary between the flexible board and the non-flexible substrate prior to the forming of the metal layer, wherein the forming of the metal layer comprises forming the metal layer over the resin layer and the flexible board.

16. The method for manufacturing a flex-rigid wiring board according to claim 1, further comprising forming a separator layer over the flexible board, wherein the separator layer is formed between the flexible board and the metal layer, and the removing of the portion of the insulating layer comprises removing the portion of the insulating layer together with the separator layer and a portion of the metal layer underneath the portion of the insulating layer.

17. The method for manufacturing a flex-rigid wiring board according to claim 1, further comprising:

forming a resin layer covering a boundary between the flexible board and the non-flexible substrate prior to the forming of the metal layer;

forming a via hole opening which passes through the resin layer; and

plating the via hole opening such that a via conductor passing through the resin layer is formed,

wherein the forming of the insulating layer comprises forming the insulating layer comprising a resin over the resin layer such that the via hole opening is filled with a portion of the resin derived from the insulating layer.

18. The method for manufacturing a flex-rigid wiring board according to claim **1**, further comprising:

forming a resin layer including an inorganic material and covering a boundary between the flexible board and the non-flexible substrate prior to the forming of the metal layer; 5

forming a via hole opening which passes through the resin layer; and

plating the via hole opening such that a via conductor passing through the resin layer is formed, 10

wherein the forming of the insulating layer comprises forming the insulating layer comprising a resin and an inorganic material over the resin layer and the flexible board.

19. The method for manufacturing a flex-rigid wiring board according to claim **1**, further comprising forming a second insulating layer over the insulating layer, wherein the forming of the insulating layer comprises forming the insulating layer comprising a resin, and the forming of the second insulating layer comprises forming the second insulating layer comprising a resin. 15 20

20. The method for manufacturing a flex-rigid wiring board according to claim **2**, further comprising:

forming a resin layer covering a boundary between the flexible board and the non-flexible substrate prior to the forming of the metal layer; 25

forming a via hole opening which passes through the resin layer; and

plating the via hole opening such that a via conductor passing through the resin layer is formed. 30

* * * * *