



US00D994358S

(12) **United States Design Patent**
O'Neill et al.

(10) **Patent No.:** **US D994,358 S**

(45) **Date of Patent:** **** Aug. 8, 2023**

- (54) **VEHICULAR SEATING SUITE**
 - (71) Applicant: **Zephyr Aerospace, LLC**, San Francisco, CA (US)
 - (72) Inventors: **Jeffrey O'Neill**, San Francisco, CA (US); **Victor Dominique Carlloz**, Manhattan Beach, CA (US)
 - (73) Assignee: **Zephyr Aerospace, LLC**, San Francisco, CA (US)
 - (**) Term: **15 Years**
 - (21) Appl. No.: **29/768,902**
 - (22) Filed: **Feb. 2, 2021**
 - (51) **LOC (14) Cl.** **06-01**
 - (52) **U.S. Cl.**
USPC **D6/356**
 - (58) **Field of Classification Search**
USPC D6/335, 336, 338, 356, 357, 360, 361, D6/367, 381, 716; D12/16, 317, 345
CPC . B60N 2/00; B60N 2/005; B60N 2/02; B60N 2/04; B60N 2/06; B60N 2/10; B60N 2/16; B60N 2/20; B60N 2/22; B60N 2/30; B60N 2/32; B64D 11/06; B64D 11/0601; B64D 11/0602; B64D 11/0606; B63B 29/04
- See application file for complete search history.

- D423,825 S 5/2000 Alcala et al.
 - 6,056,239 A * 5/2000 Cantu B64D 11/06 244/118.6
 - D558,993 S 1/2008 Saint-Jalmes et al.
 - D615,476 S 5/2010 Bock
 - D617,725 S 6/2010 Collins et al.
 - D696,033 S 12/2013 Ersan et al.
 - D696,524 S 12/2013 Ersan et al.
 - D718,945 S 12/2014 Nicholas et al.
 - D720,160 S 12/2014 Lloyd et al.
- (Continued)

OTHER PUBLICATIONS

Design 6152101, Application date Aug. 2, 2021, country code GB, Publication date Aug. 2, 2021, owner Zephyr Aerospace LLC (Year: 2021).*

(Continued)

Primary Examiner — Mary Ann Calabrese
Assistant Examiner — Mark David Wolfley
(74) *Attorney, Agent, or Firm* — Shumaker, Loop & Kendrick, LLP; S. Alexander Long, Jr.

(57) **CLAIM**

The ornamental design for a vehicular seating suite, as shown and described.

DESCRIPTION

FIG. 1 is a top, front, right perspective view of a vehicular seating suite showing my new design; FIG. 2 is a front elevational view thereof; FIG. 3 is a rear elevation view thereof; FIG. 4 is a left side elevation view thereof; FIG. 5 is a right side elevation view thereof; FIG. 6 is a top plan view thereof; and, FIG. 7 is a bottom plan view thereof. The broken lines are included for the purpose of illustrating portions of the vehicular seating suite that form no part of the claimed design.

1 Claim, 7 Drawing Sheets

(56) **References Cited**

U.S. PATENT DOCUMENTS

- D148,691 S 2/1948 Graef
- D148,740 S 2/1948 Allen
- 2,966,199 A * 12/1960 Waerner B60N 2/34 5/8
- D202,980 S 11/1965 Carson
- D226,464 S 3/1973 Genaro et al.
- D245,706 S 9/1977 McAllister
- 4,854,245 A 8/1989 Platzer
- 5,716,026 A 2/1998 Pascasio et al.

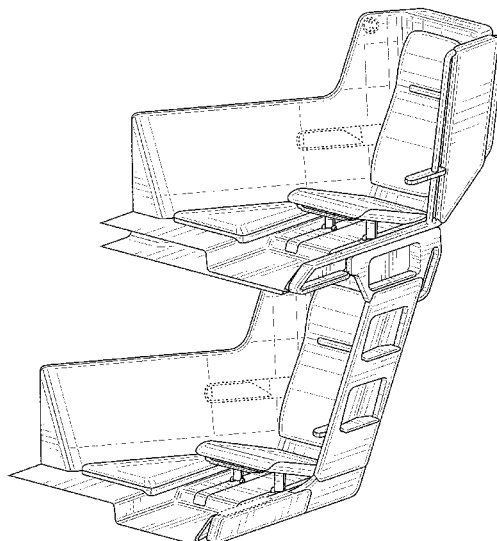

(56)

References Cited

U.S. PATENT DOCUMENTS

D727,042 S 4/2015 Wagner et al.
 D733,442 S * 7/2015 Dryburgh D6/356
 D765,999 S 9/2016 Goode et al.
 D768,400 S 10/2016 Berry et al.
 D780,938 S 3/2017 McGrath et al.
 D790,239 S 6/2017 Goode et al.
 D792,130 S 7/2017 Poranen
 D806,416 S 1/2018 Katakura et al.
 D806,417 S 1/2018 Katakura et al.
 9,856,025 B2 1/2018 Jasny et al.
 D809,811 S 2/2018 Moyes et al.
 9,919,800 B2 3/2018 Caillateau et al.
 D824,183 S 7/2018 Bryant
 D830,712 S 10/2018 Goode et al.
 D856,692 S 8/2019 Veneruso
 D885,774 S 6/2020 Bonneywell
 D893,931 S * 8/2020 Katakura D6/716
 D901,197 S * 11/2020 Katakura D6/356
 D901,199 S * 11/2020 Katakura D6/356
 D939,849 S * 1/2022 Saint-Jalmes D6/356
 D948,880 S * 4/2022 Saint-Jalmes D6/356
 11,364,822 B1 * 6/2022 Rajasingham B60N 2/2884
 2010/0065683 A1 3/2010 Darbyshire
 2011/0011977 A1 1/2011 Olliges
 2012/0104165 A1 5/2012 Dobrusin et al.
 2014/0035330 A1 2/2014 Henshaw
 2014/0197667 A1 7/2014 Cheung et al.
 2015/0001341 A1 1/2015 Ersan et al.
 2015/0274298 A1 10/2015 Kircher et al.
 2016/0194084 A1 * 7/2016 Rajasingham B64D 11/0601
 2016/0272323 A1 9/2016 Carlouz et al.
 2018/0056846 A1 3/2018 Nasiri

2019/0308733 A1 10/2019 O'Neill et al.
 2020/0070691 A1 3/2020 Glain et al.
 2020/0238880 A1 7/2020 Valdes De La Garza et al.

OTHER PUBLICATIONS

Zephyr Seat, posted on travelandleisure.com, published Jun. 24, 2020, site visited Feb. 2, 2023, URL:<https://www.travelandleisure.com/culture-design/architecture-design/double-decker-airplane-zephyr-seat-design> (Year: 2020).*

Zephyr Seat Facebook, posted on Facebook.com, posted on Jun. 22, 2020, site visited on Feb. 2, 2023, URL:<https://www.facebook.com/photo/?fbid=140495900997115&set=a.113073167072722> (Year: 2020).*

Non-Final Office Action issued in related U.S. Appl. No. 29/686,315 dated Sep. 23, 2020.

Notice of Allowance issued in related U.S. Appl. No. 29/686,311 dated Oct. 1, 2020.

Ex-Parte Quayle Action issued in related U.S. Appl. No. 29/686,311 dated Sep. 28, 2020.

"Delta Gets Comfy with Full Flat-Bed Seats", Apr. 22, 2014, [travelpulse.com](https://www.travelpulse.com/news/airlines/delta-gets-comfy-with-flat-bed-seats.html) site visited Sep. 16, 2020 <<https://www.travelpulse.com/news/airlines/delta-gets-comfy-with-flat-bed-seats.html>> (Year: 2014), 1 page.

Salton, J. "The Flex-Seat Offers Even Economy Class Fliers the chance of a good night's sleep", Dec. 8, 2009, [newatlas.com](https://newatlas.com/airline-seating-innovation/13535/) site visited Sep. 16, 2020, <<https://newatlas.com/airline-seating-innovation/13535/>> (Year: 2009), 1 page.

Notice of Allowance issued in related U.S. Appl. No. 29/686,315 dated Dec. 10, 2020.

Notice of Allowance issued in related U.S. Appl. No. 29/686,311 dated Dec. 24, 2020.

International Search Report issued in related PCT Application Serial No. PCT/US2019/025541 dated Jun. 21, 2019.

* cited by examiner

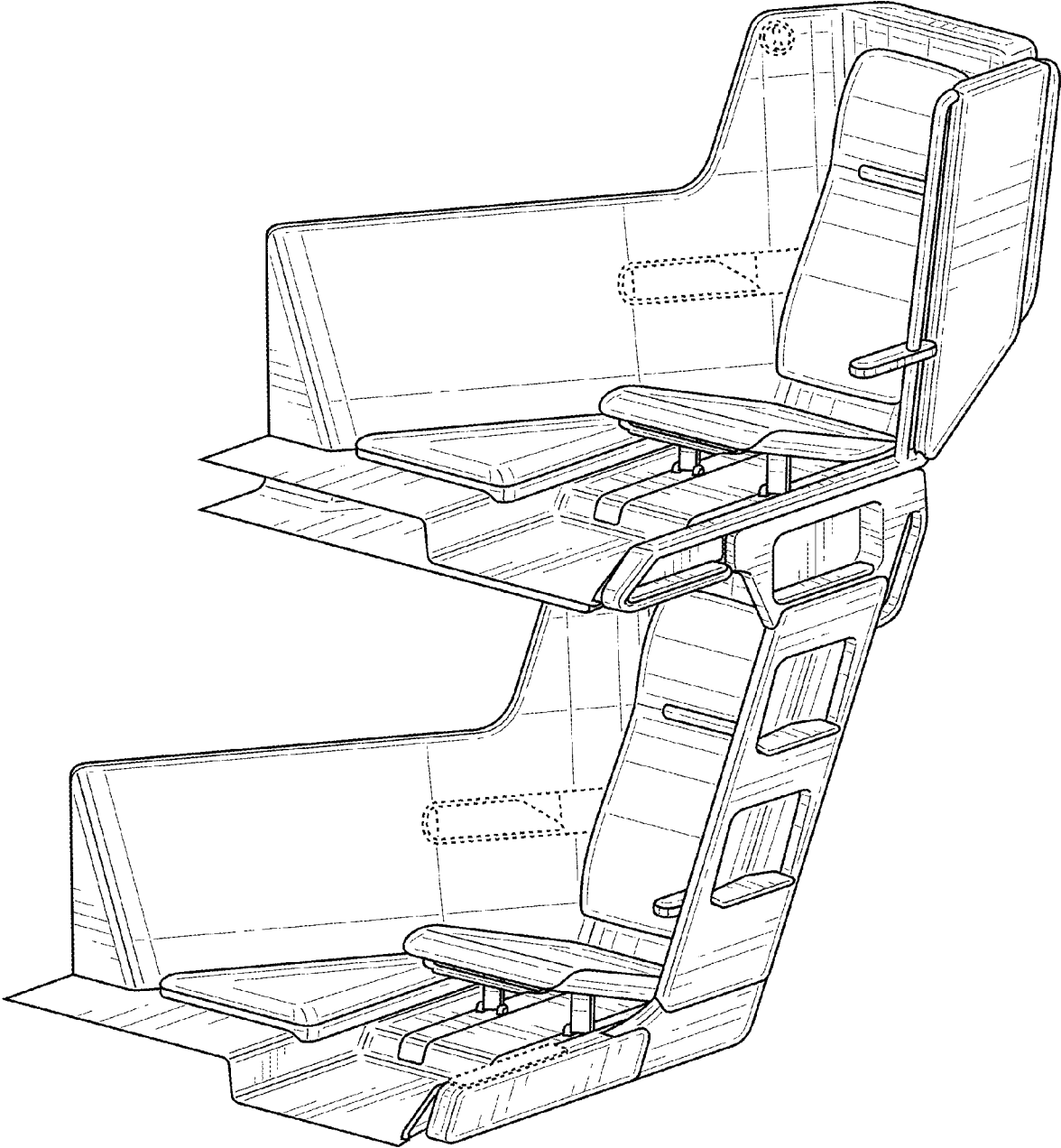

FIG. 1

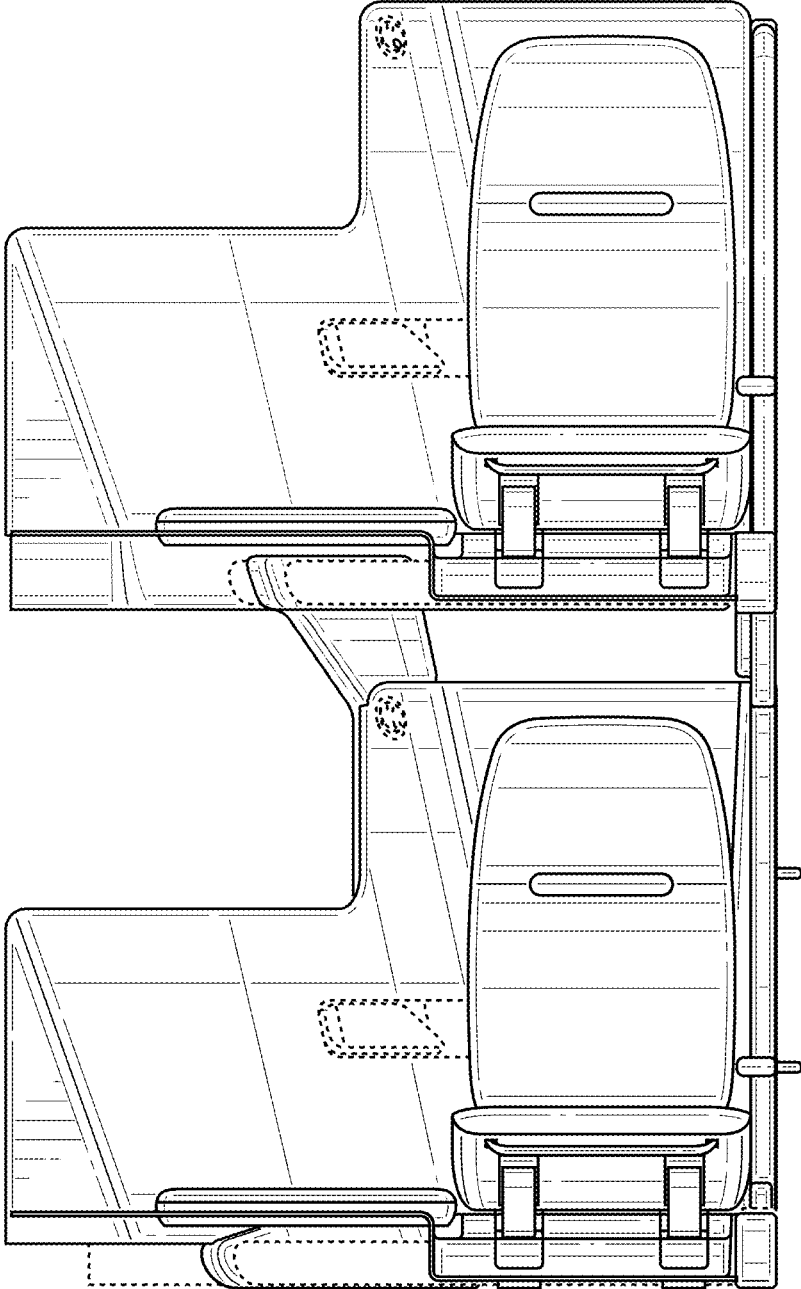

FIG. 2

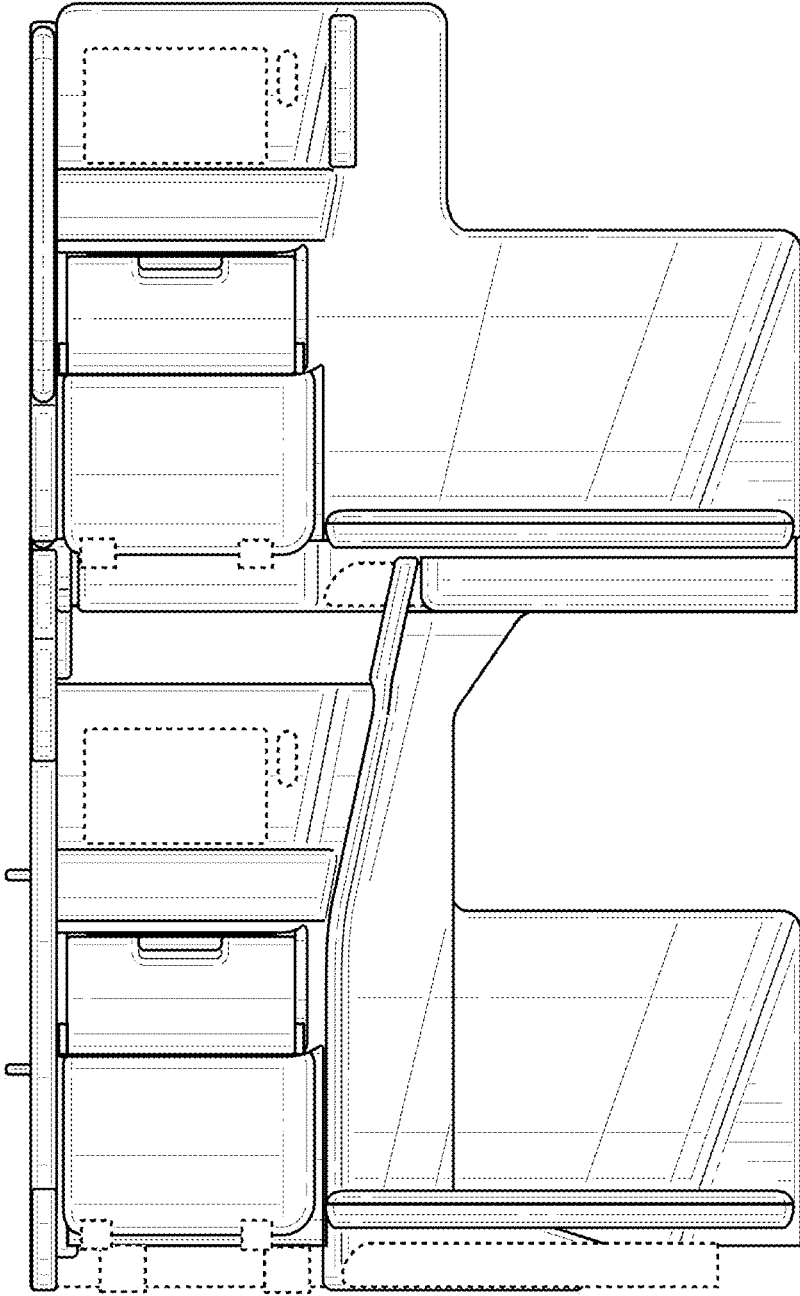

FIG. 3

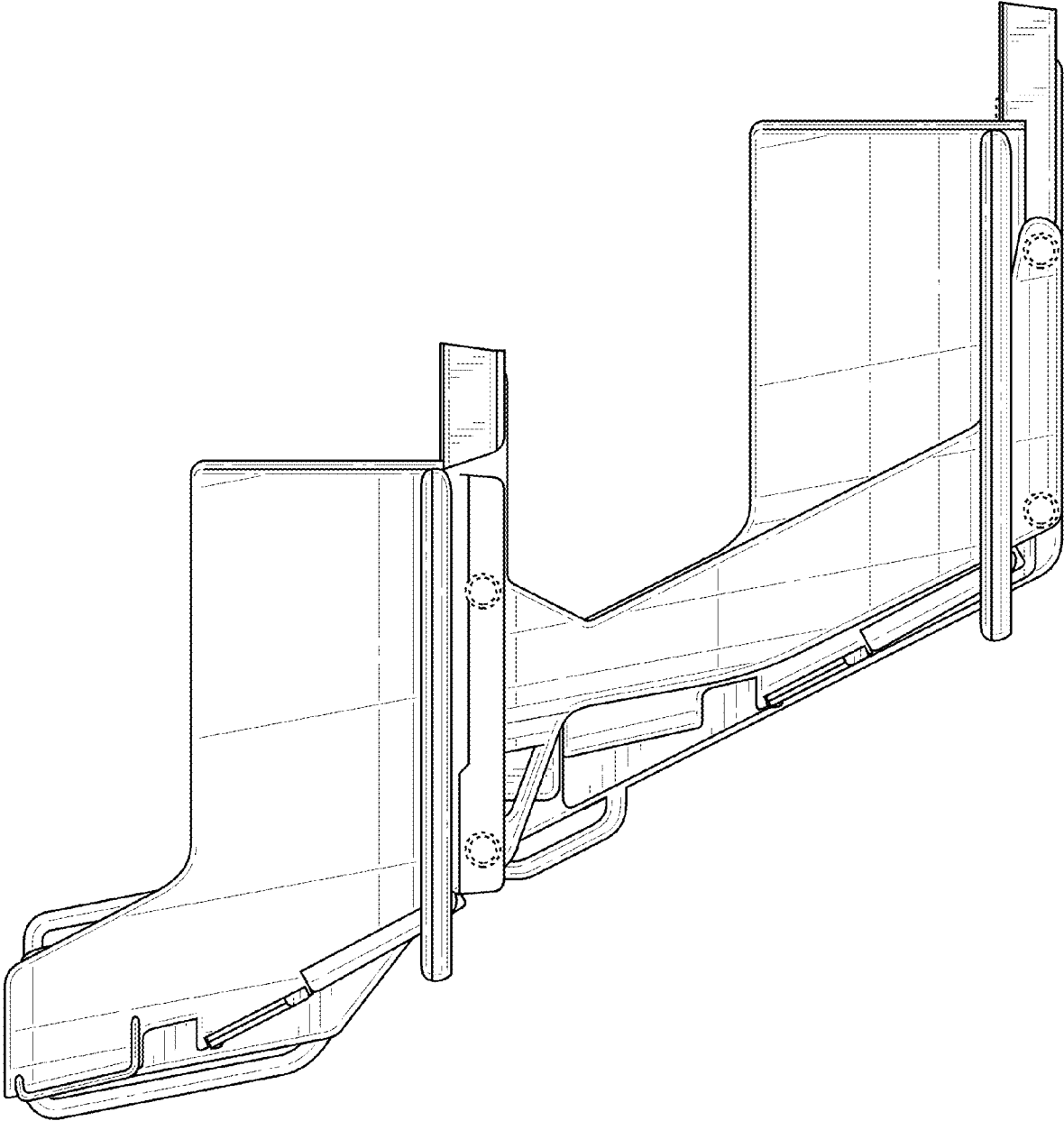

FIG. 4

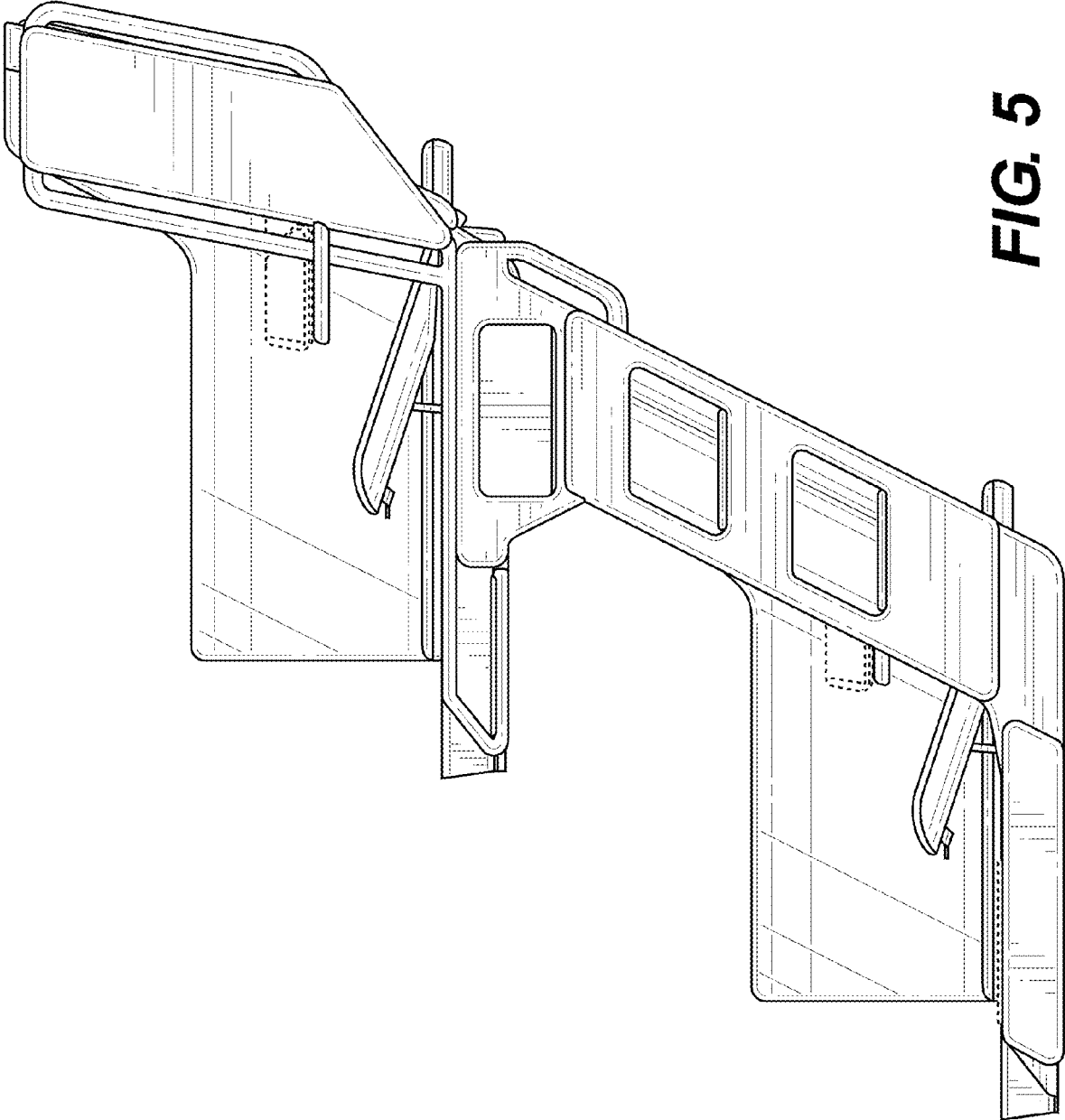

FIG. 5

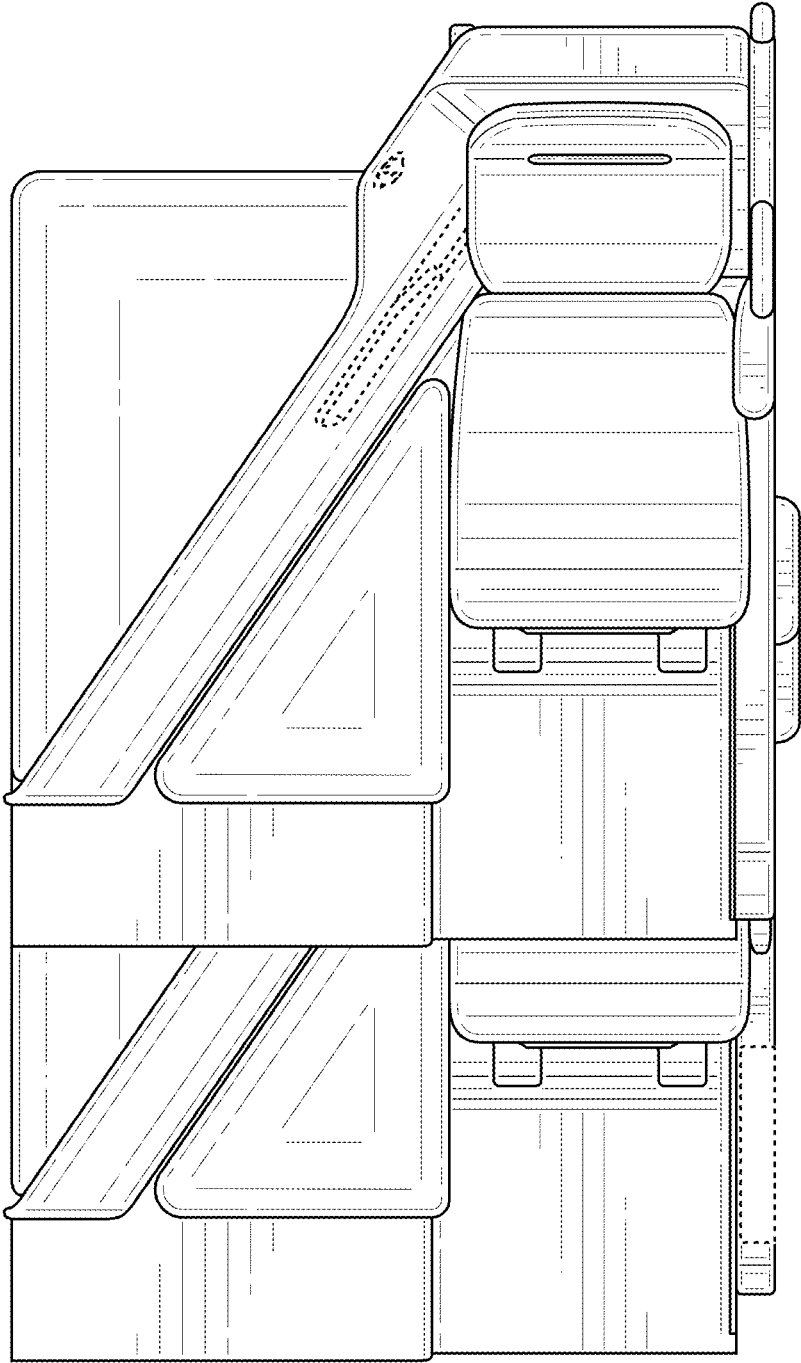

FIG. 6

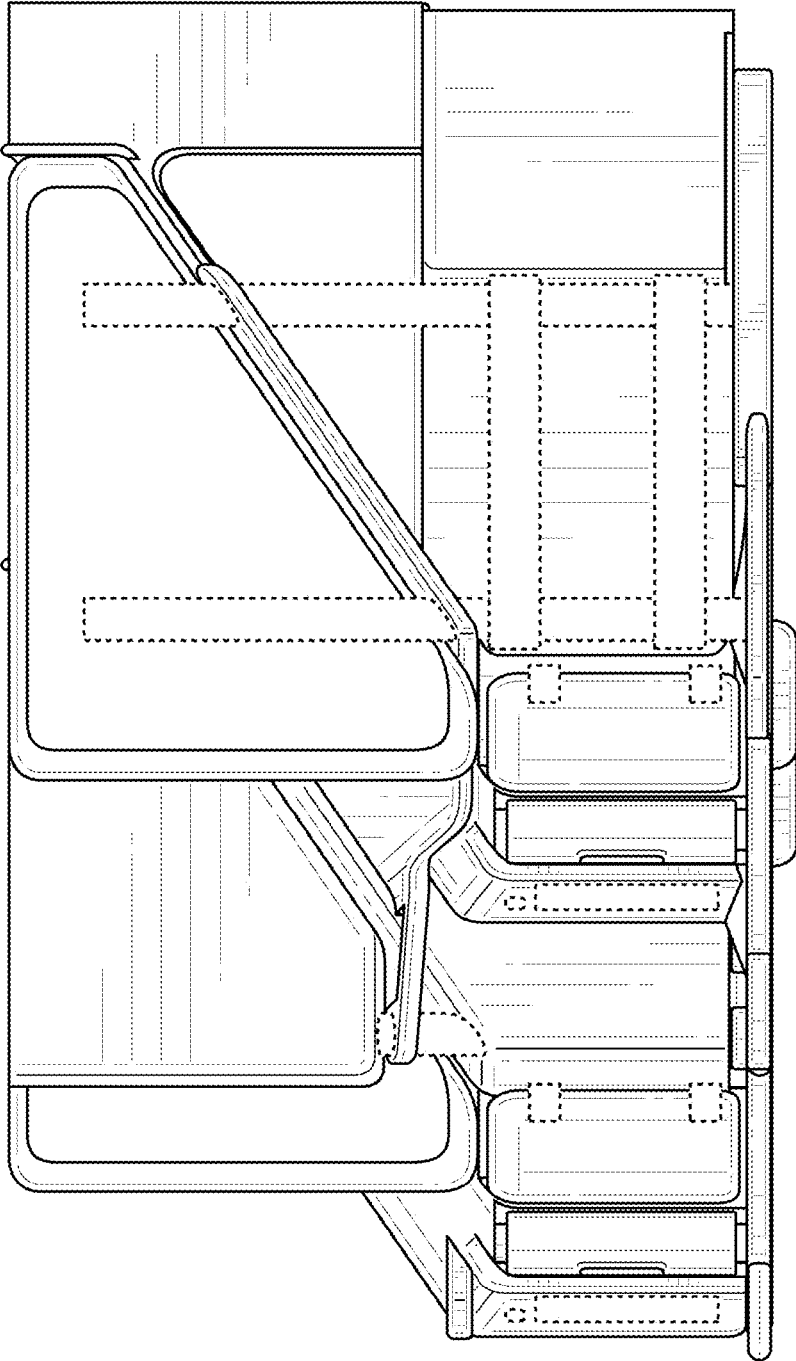

FIG. 7