

March 29, 1960

R. H. WOOD

2,931,004

HIGH VOLTAGE POWER LINE CLAMP

Filed April 24, 1956

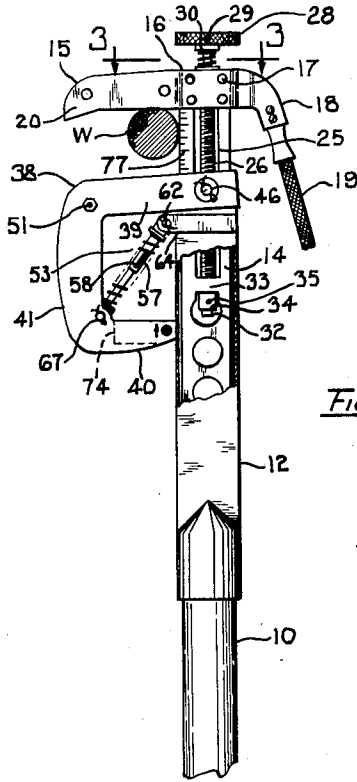

Fig. 1

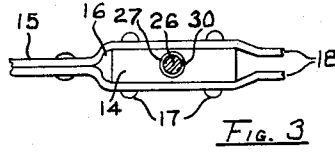

Fig. 3

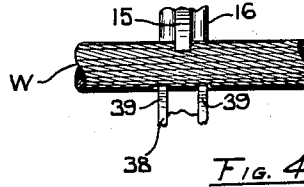

Fig. 4

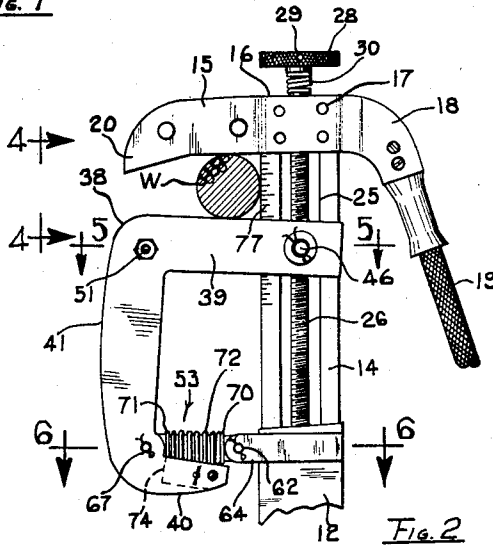

Fig. 2

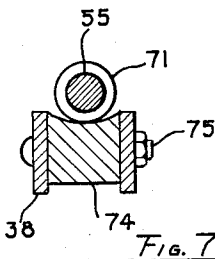

Fig. 7

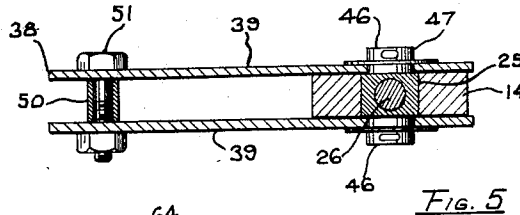

Fig. 5

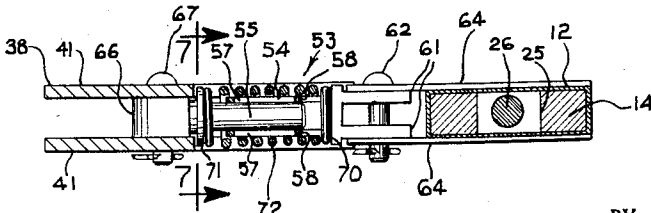

Fig. 6

INVENTOR.

RICHARD H. WOOD

BY

Cook and Schermerhorn
ATTORNEYS

1

2,931,004

HIGH VOLTAGE POWER LINE CLAMP

Richard H. Wood, Vancouver, Wash.

Application April 24, 1956, Serial No. 580,294

7 Claims. (Cl. 339-109)

This invention relates to improvements in electrical contact clamps for connecting a ground wire or other tap to an electrical bus or conductor.

For repair purposes in conjunction with live electrical busses or conductors, it is the practice to ground the conductor on each side of the fault to render the circuit safe for the linemen or electricians. To insure a positive grounding of the conductor it is necessary that the ground wire have a good electrical connection with the conductor and also have a good mechanical connection therewith so that it cannot accidentally become disconnected therefrom and imperil the safety of the linemen. In addition to the requirement of establishing a positive grounding of the conductor, it is also highly desirable that means be provided for quickly attaching the ground wire to and detaching it from said conductor to save valuable time during which the power customer may be without service and a large crew of workmen may be standing idle. The same considerations also often apply to the connection of a temporary power tap to a bus or other bare conductor.

It is, therefore, a principal object of the present invention to provide an improved electrical contact clamp which provides a quick and convenient means of establishing a positive electrical and mechanical connection with a line conductor or bus.

More specific objects of the invention are to provide an electrical contact clamp which has improved jaw means cooperating to obtain a firm grip on a conductor; which has jaw means conveniently adjustable in spaced relation for engaging conductors of different sizes; which has resilient means operative on said jaw means to provide an improved engagement with the conductor in the clamped position of the parts; and which is easy to manipulate.

The above enumerated objects are accomplished by an electrical contact clamp having a suitable flexible lead attached thereto and having structure whereby the clamp is attached to or detached from a conductor by a single push or pull manipulation of an insulated handle thereon. More specifically, the device utilizes a pair of jaw members which are arranged firmly to clamp a conductor therebetween by a pull on the handle and readily to release the grip on the conductor by a push on the handle. One of the jaws is locked in either a clamped or released position by a spring pressed toggle mechanism.

The invention will be better understood and additional objects and advantages will become apparent from the following description taken in connection with the accompanying drawings which illustrate a preferred form of the invention. It is to be understood, however, that the invention may take other forms and that all such modifications and variations within the scope of the appended claims, which will occur to persons skilled in the art, are included in the invention.

In the drawings:

Figure 1 is a side elevational view of the present clamp in open or released position;

2

Figure 2 is a side elevational view of the clamp in closed position for clamping a conductor;

Figure 3 is a sectional view taken on the line 3-3 of Figure 1;

Figure 4 is a fragmentary front elevational view taken on the line 4-4 of Figure 2;

Figure 5 is a sectional view taken on the line 5-5 of Figure 2;

Figure 6 is a sectional view taken on the line 6-6 of Figure 2; and

Figure 7 is a sectional view taken on the line 7-7 of Figure 6.

Referring in detail to the drawings, the present clamp comprises a handle 10 of non-conductive material, such as wood, having secured to its upper end a metallic sleeve 12 assuming a rectangular configuration in cross section, Figure 6. Mounted in the sleeve 12 for relative slidable movement is a shank or leg 14 forming an integral extension of an end jaw member 15. Jaw 15 is formed with a socket 16 therein for receiving the shank 14 and suitable means, such as rivets 17, are employed to secure these parts together in an integral structure. Arm portions 18 project rearwardly from the socket and are securely attached to a flexible lead 19. Jaw 15 is formed from a strong conductive metal and has a good electrical connection with the lead 19 so that current from a conductor W can flow directly to lead 19 when the clamp is closed. Jaw 15 has a slightly hooked outer end 20.

Shank 14 is provided with a slot 25 intermediate its ends in which is disposed a screw 26 extending through a smooth bore 27 in the outer end of the shank and having a turning knob 28 firmly anchored in non-rotative relationship therewith by a set screw or pin 29. A compression spring 30 is mounted on the screw 26 between the knob 28 and the end of shank 14. The end of screw 26 opposite from the turning knob terminates in a reduced unthreaded portion 32 which projects through a transverse web 33 across the slot 25 and this reduced portion 32 receives a collar 34. Collar 34 is anchored on the screw 26 by a set screw 35, and, while it restricts outward movement of the screw relative to the shank, it does not restrict inward movement or rotation of the screw.

Cooperating with the relatively stationary end jaw 15 is a movable jaw 38 comprising a pair of identical spaced plate members assuming substantially a C-shape and each having spaced arm portions 39 and 40 interconnected by an arm portion 41. The plate members of jaw 38 are disposed on opposite sides of the plane of jaw 15 to afford a stable three-point gripping engagement with the conductor W, making a positive mechanical and electrical connection therewith. The conductor engaging surfaces of jaws 15 and 38 are preferably of the same material as the conductor to be clamped, or a slightly softer metal so as to avoid scratching or marring the conductor.

The arm portions 39 of jaw 38 at their free ends straddle the shank 14 and are pivotally mounted on a pair of trunnion pins 46 to projecting from a nut forming a hinge pin slide 47 threadedly mounted on the screw 26. The plate members of jaw 38 are held in spaced relation at their pivoted ends by the shank 14 and also are held in proper spaced relation adjacent the mouth of the clamp by a spacer member 50, Figure 5, supported on a bolt 51.

The movable jaw 38 is thus arranged to pivot relative to the end jaw 15, and this movable jaw is locked in open or closed positions by an over-center toggle mechanism 53 connected therewith and shown in detail in Figure 6. Toggle mechanism 53 comprises a pair of telescoping members 54 and 55 which cause the movable jaw to rotate away from the handle 10 in a clamping operation. The member 54 is slotted on both sides at 57 for slidably receiving pins 58 on the member 55, and

3

this member has bifurcated arm portions 61 rotatable on a pin 62 mounted in a pair of lugs 64 on the sleeve 14. Member 55 is secured to a bushing 66 disposed between arm portions 41 of the jaw member 38 and journaled on a pin 67 mounted in said arm portions, the pin 67 being mounted in the arm portions 41 adjacent the end distant from the jaw opening. Telescoping members 54 and 55 have annular flange portions 70 and 71, respectively, between which is confined a compression spring 72. The toggle structure is such that the spring 72 is compressed at all times to produce a locking force on the movable jaw in either the open or closed position of the clamp.

The arm portions 40 of jaw 38 are held in proper spaced relation by a block 74, Figure 7, secured between said arm portions in a suitable manner, such as by a bolt 75. Block 74 has a curved top surface engageable by the spring assembly comprising the barrel of spring 72 and flanges 70 and 71 and serves as an abutment to limit the closing movement of the toggle mechanism and the movement of sleeve 12 away from the pivot points 46 in the closed position of the clamp.

With regard to the operation, Figure 1 shows the open position of the clamp and Figure 2 shows the closed position thereof. To clamp the device on a conductor W the end jaw 15 is hooked over said conductor and a pull away from the conductor is exerted on the handle 10. This pull on the handle moves the sleeve 12 and lugs 64 therewith away from the pivoted end of the jaw 38 and the swinging end of the toggle mechanism 53 moves therewith. As the swinging end of the toggle mechanism starts moving away from the arm portions 39 of jaw 38, it causes the movable jaw to pivot into engagement with the conductor. At the end of this stroke the toggle mechanism has passed beyond its over-center position, as shown in Figure 2, and it locks the clamp in closed position. In the closed position of the clamp, the spring 72 is almost fully compressed to exert a great enough force on the jaw 38 to hold the clamp in firm mechanical and electrical connection with the conductor.

To release or unlock the clamp, the handle 10 is pushed toward the conductor W. This movement of the handle moves the swinging end of the toggle mechanism toward the arm portions 39 of jaw 38 past its dead center position whereupon the jaw releases its hold on the conductor and swings away from the conductor until block 74 engages sleeve 12. The type of conductor W to which the clamp is applied is sufficiently heavy and stiff to be substantially rigid and immovable when the handle is pulled and pushed in the manner described.

The size opening of the jaws is readily varied for conductors of different sizes by turning the knob 28 to rotate the screw 26. This adjustment raises or lowers the hinge pin slide 47 relative to the jaw 15 to obtain the proper jaw setting. To aid in a proper jaw setting, shank 14 has a scale 77 thereon. Thus, the same clamping action may be obtained on a conductor of any size within the range of the tool. The clamping action may be tightened or loosened for a conductor of any size within this range by turning knob 28 to move jaw 38 to a scale position slightly smaller or larger than the actual diameter of the conductor.

When jaw 38 is adjusted by knob 28 to the scale position corresponding to the actual conductor diameter, this jaw enters into clamping engagement with the conductor slightly before block 74 engages flange 71. The force of spring 72 then pivots jaw 38 about the conductor as a fulcrum, moving pin slide 47 and screw 26 away from jaw 15 and compressing spring 30 to a greater extent until block 74 engages flange 71, which limits the compression of spring 30. If jaw 38 is adjusted by knob 28 to a scale position larger than the actual conductor diameter, the clamping movement of jaw 38 is stopped by block 74 before any substantial movement of pin slide 47 occurs, whereby little or no additional compres-

4

sion of spring 30 is produced and a lighter grip on the conductor is obtained.

A very tight clamping action can be produced by turning knob 28 to adjust jaw 38 to a scale position slightly less than the actual conductor diameter. Then jaw 38 engages the conductor considerably before block 74 is stopped by flange 71 and pin slide 47 is pulled farther away from jaw 15 to compress spring 30 a greater amount. The clamping effect is produced by the joint action of springs 30 and 72 on opposite ends of the jaw 38, the amount of assistance offered by spring 30 depending upon the position of pin slide 47 in relation to the diameter of the conductor. Thus, the clamping action can be adjusted by the operator as desired.

The present clamp is not limited to use on round conductors but may be applied with equal effectiveness to conductors of any cross sectional shape.

Having now described my invention and in what manner the same may be used, what I claim as new and desire to protect by Letters Patent is:

1. An electrical contact clamp comprising an elongated handle, a first transverse clamp jaw having a shank slidable longitudinally in one end of said handle, a longitudinal adjusting screw in said shank, a nut on said screw adjustable longitudinally of said shank by rotation of said screw, a second transverse clamp jaw pivotally mounted on said nut, and a toggle link connected between said second jaw and said handle, one end of said link being movable by push-pull movements of said handle on said shank to over-center positions locking said second clamp jaw in unclamped and clamped positions.

2. An electrical contact clamp comprising an elongated handle, a first transverse clamp jaw having a shank slidable longitudinally in one end of said handle, a longitudinal adjusting screw having longitudinal sliding movement in said shank, a spring normally holding said screw at a limit of outward movement in said shank, said screw having an outer end equipped with an adjusting knob, a nut on said screw adjustable longitudinally of said shank by rotation of the screw, a second transverse clamp jaw pivotally mounted on said nut, and a toggle link connected between said second jaw and said handle, one end of said link being movable by push-pull movements of said handle on said shank to over-center positions locking said second clamp jaw in unclamped and clamped positions.

3. An electrical contact clamp comprising an elongated handle, a shank member slidable longitudinally at one end of said handle, a first transverse conductor clamp jaw on the outer end of said shank member, said shank member including a longitudinal adjustment screw and a nut on said screw, a second transverse conductor clamp jaw pivotally mounted on said nut for longitudinal clamping and unclamping movements on said shank member, and a toggle spring connected between said second jaw and said handle, one end of said spring being movable by said handle to an over-center position urging said second jaw toward said first jaw and to an over-center position urging said second jaw away from said first jaw.

4. A clamp as defined in claim 3 including a resilient thrust abutment for one end of said screw.

5. A single handle electrical contact clamp comprising an elongated pole handle, an L-shaped clamp jaw having an elongated shank mounted for longitudinal sliding movement in a forward end of said handle and a hooked conductor engaging portion projecting transversely from said shank and handle, a hinge pin slide in said shank, a second jaw projecting transversely from said shank and pivotally mounted on said hinge pin slide for clamping a conductor between said jaws, means for adjusting said hinge pin slide longitudinally of said shank for clamping conductors of different sizes, an angular extension on said second jaw extending rearwardly away from said first jaw, and a toggle spring having an end connected

5

to said jaw extension and an opposite end connected to said handle, said handle connection being movable to an over-center position forward from said jaw connection to open said second jaw when the handle is pushed toward said jaws and said handle connection between movable to a rearward over-center position locking said second jaw in clamped position when said handle is pulled away from said jaws.

6. An electrical contact clamp comprising a single elongated handle, an elongated shank mounted for longitudinal sliding movement in one end of said handle, a hooked conductor engaging clamp jaw secured to and projecting transversely from said shank, a hinge pin carried by said shank, a second clamp jaw projecting transversely from said shank and pivotally mounted on said hinge pin for clamping a conductor between said jaws, means for adjusting said hinge pin longitudinally of said shank for clamping conductors of different sizes, and a toggle spring connected between said second jaw and said handle in such relation that a pull on said handle in a direction away from said jaws moves the handle end of said spring to an over-center position locking said second jaw in clamped position and a push on said handle toward said jaws moves the handle end of said spring to an over-center position locking said second jaw in unclamped position.

7. A single handle electrical contact clamp comprising an elongated pole handle, an elongated shank mounted

6

for longitudinal sliding movement in a forward end of said handle, a hooked conductor engaging clamp jaw secured to and projecting transversely from said shank, a hinge pin carried by said shank, a second clamp jaw projecting transversely from said shank and pivotally mounted on said hinge pin for clamping a conductor between said jaws, means for adjusting said hinge pin longitudinally of said shank for clamping conductors of different sizes, and a toggle spring connected between said second jaw and said handle, one end of said spring being connected to said jaw and the other end connected to said handle at a point forward from said jaw connection when said jaw is open, said handle connection being movable to an over-center position locking said second jaw in clamped position when said handle is pulled in a direction away from said jaws, said handle when pushed toward said jaws moving said handle connection to an over-center position at said forward point locking said second jaw in said open position.

References Cited in the file of this patent

UNITED STATES PATENTS

1,493,517	Bush	May 13, 1924
1,777,395	Coon	Oct. 7, 1930
1,833,756	Perazzoli	Nov. 24, 1931
1,862,073	Woolson	June 7, 1932