



INTERNATIONAL APPLICATION PUBLISHED UNDER THE PATENT COOPERATION TREATY (PCT)

<p>(51) International Patent Classification ⁶ : G01R 21/133</p>	<p>A1</p>	<p>(11) International Publication Number: WO 98/52057</p> <p>(43) International Publication Date: 19 November 1998 (19.11.98)</p>
<p>(21) International Application Number: PCT/US98/09555</p> <p>(22) International Filing Date: 11 May 1998 (11.05.98)</p> <p>(30) Priority Data: 08/857,322 16 May 1997 (16.05.97) US</p> <p>(71) Applicant: GENERAL ELECTRIC COMPANY [US/US]; 1 River Road, Schenectady, NY 12345 (US).</p> <p>(72) Inventors: LAVOIE, Gregory, Paul; 73 Brook Farm Village, Rochester, NH 03839 (US). ELMORE, David, Dean; 78 Stackpole Road, Somersworth, NH 03878 (US). SCHMIDT, Larry, Alan; 314 Rochester Hill Road #1D, Rochester, NH 03867 (US). BULLOCK, Donald, Frank; 6 Fern Way, Madbury, NH 03878 (US). ROSENAU, Leslie, James; 8 Crestview Drive, Dover, NH 03820 (US).</p> <p>(74) Agents: STECKLER, Henry, I. et al.; General Electric Company, 3135 Easton Turnpike W3C, Fairfield, CT 06431 (US).</p>	<p>(81) Designated States: BR, CN, MX, European patent (AT, BE, CH, CY, DE, DK, ES, FI, FR, GB, GR, IE, IT, LU, MC, NL, PT, SE).</p> <p>Published <i>With international search report.</i></p>	

(54) Title: CONFIGURABLE ELECTRICITY METER

(57) Abstract

An electricity meter which, in one embodiment, includes a digital signal processor configurable for generating energy measurements for a plurality of meter form types and connections is described. In the one embodiment, the meter includes voltage and current sensor for generating signals representative of current and voltage at a load, and the digital signal processor (DSP) is coupled to the voltage and current sensors. The DSP includes a memory, and a plurality of selectable instruction sets corresponding to respective meter form types are stored in the DSP memory. The form types include meter ANSI form 9 and meter ANSI form 16 type forms, and the instruction sets include processing steps to be executed to determine line voltages and line currents for respective meter form types. The meter also includes a microcomputer coupled to the DSP for receiving data generated by the DSP. The microcomputer is operable to transmit a selection command to the DSP to control selection of one of the instruction sets stored in the DSP memory. An optical port may be electrically coupled to the microcomputer, and the microcomputer is configured to receive a control command from the optical port. The microcomputer uses the control command to generate the selection command.

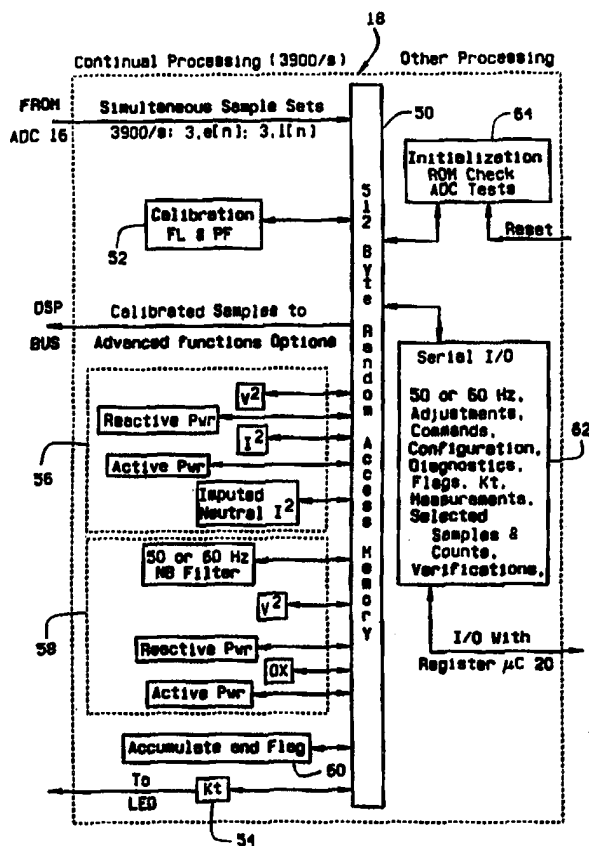

FOR THE PURPOSES OF INFORMATION ONLY

Codes used to identify States party to the PCT on the front pages of pamphlets publishing international applications under the PCT.

AL	Albania	ES	Spain	LS	Lesotho	SI	Slovenia
AM	Armenia	FI	Finland	LT	Lithuania	SK	Slovakia
AT	Austria	FR	France	LU	Luxembourg	SN	Senegal
AU	Australia	GA	Gabon	LV	Latvia	SZ	Swaziland
AZ	Azerbaijan	GB	United Kingdom	MC	Monaco	TD	Chad
BA	Bosnia and Herzegovina	GE	Georgia	MD	Republic of Moldova	TG	Togo
BB	Barbados	GH	Ghana	MG	Madagascar	TJ	Tajikistan
BE	Belgium	GN	Guinea	MK	The former Yugoslav Republic of Macedonia	TM	Turkmenistan
BF	Burkina Faso	GR	Greece			TR	Turkey
BG	Bulgaria	HU	Hungary	ML	Mali	TT	Trinidad and Tobago
BJ	Benin	IE	Ireland	MN	Mongolia	UA	Ukraine
BR	Brazil	IL	Israel	MR	Mauritania	UG	Uganda
BY	Belarus	IS	Iceland	MW	Malawi	US	United States of America
CA	Canada	IT	Italy	MX	Mexico	UZ	Uzbekistan
CF	Central African Republic	JP	Japan	NE	Niger	VN	Viet Nam
CG	Congo	KE	Kenya	NL	Netherlands	YU	Yugoslavia
CH	Switzerland	KG	Kyrgyzstan	NO	Norway	ZW	Zimbabwe
CI	Côte d'Ivoire	KP	Democratic People's Republic of Korea	NZ	New Zealand		
CM	Cameroon			PL	Poland		
CN	China	KR	Republic of Korea	PT	Portugal		
CU	Cuba	KZ	Kazakistan	RO	Romania		
CZ	Czech Republic	LC	Saint Lucia	RU	Russian Federation		
DE	Germany	LI	Liechtenstein	SD	Sudan		
DK	Denmark	LK	Sri Lanka	SE	Sweden		
EE	Estonia	LR	Liberia	SG	Singapore		

CONFIGURABLE ELECTRICITY METER

Field of the Invention

This invention relates generally to electricity metering and more particularly, to an electronic electricity meter configurable to operate in a plurality of meter forms and ratings.

Background of the Invention

Since data collected from metering electric services within an electric distribution network is used for billing customers, the collected data must be accurate. To ensure accuracy, and in the past, different meter forms are used to meter energy consumption for different types of electric services and load ranges. Specifically, within an electric distribution network of a utility, there are many different services and loads which a utility desires to meter. Each type of service and load may require a meter having a particular "form" and "rating". The term "form" as used in the art refers to the physical configuration of an electrical service, and the term "rating" refers to both voltage and current range.

From application to application, the form and rating of the electricity meter required to accurately meter energy consumption may vary. Although broad current range and wide voltage range meters have reduced the number of different meter types required for such metering applications, meters having many different forms and ratings are still required by each utility.

Of course, requiring a utility to have on hand meters with a number of different forms and ratings results in increasing the costs associated with providing electric service. Particularly, different form and rated meters typically are stored in inventory so that when a metering application is identified which requires a particular form and rated meter, the meter is readily available and can be installed. In addition to the inventory costs, utility personnel must be trained on installation of each different form and rated meter. Of course,

-2-

requiring skilled workers trained in the installation of a wide variety of meter types to install the meters also is costly.

It would be desirable to provide one meter capable of being used in a plurality of different applications requiring different forms and ratings to facilitate reducing the inventory and labor costs associated with metering a wide
5 variety of electrical services. It also would be desirable to provide such a meter which does not adversely impact the accuracy of the energy measurements made.

Summary of the Invention

10 These and other objects may be attained by an electricity meter which, in one embodiment, a digital signal processor configurable for generating energy measurements for a plurality of meter form types and connections. More particularly, and in the one embodiment, the meter includes voltage and current sensor for generating signals representative of current and voltage at a load, and
15 the digital signal processor (DSP) is coupled to the voltage and current sensors. The DSP includes a memory, and a plurality of selectable instruction sets corresponding to respective meter form types are stored in the DSP memory. The form types includes meter ANSI form 9 and meter ANSI form 16 type forms, and the instruction sets include processing steps to be executed to
20 determine line voltages and line currents for respective meter form types.

The meter also includes a microcomputer coupled to the DSP for receiving data generated by the DSP. The microcomputer is operable to transmit a selection command to the DSP to control selection of one of the instruction sets stored in the DSP memory. An optical port may be electrically
25 coupled to the microcomputer, and the microcomputer is configured to receive a control command from the optical port. The microcomputer uses the control command to generate the selection command.

When fabricating the above described meter, a meter base is selected to at the factory. As is known in the art, and by way of example with respect to

meter socket types, the meter base configuration may conform to the ANSI 9S socket configuration or the ANSI 16S socket configuration. With respect to bottom connected meter types, the meter base configuration may conform to ANSI 10A, 48A or 16A configurations. Depending on the meter base configuration, the DSP memory is then loaded with instruction sets for all possible applications for that particular base. For example, a meter having a base which conforms to an ANSI 9S socket may have a 3 element, a 2 1/2 element, a 2 element, or a 1 element connection between the meter and the power lines. In addition, and for each of the various number of elements, the specific electric circuit to which meter is actually is used depends upon the electric service, e.g., an ANSI 9S form, 3 element connection may be electrically connected to a 4W-Y configuration or a 4W-delta configuration. All the instructions sets for the various meter forms reside in the DSP ROM memory, and the instruction sets contain the process steps to be executed for each of the possible applications for the particular meter base. The meter is preprogrammed at the factory so that the most commonly used instruction set for the meter base is selected for execution by the DSP, and the meter is then delivered to the utility.

At the utility, and for an ANSI 9S base meter for example, a worker may install the meter in any ANSI 9S socket. If the electric connection between the meter and the power lines at that particular installation correspond to the preprogrammed selected instruction set, then the worker need not take any further action with respect to proper installation. If the particular installation does not correspond to the preprogrammed selected instruction sets, the worker may then select the appropriate instruction set or sets by transmitting a select signal to the microcomputer via the optical port. The microcomputer then transmits the command signal to the DSP instructing the DSP to execute a particular preloaded instruction set corresponding the electric circuit at the installation.

With the above described meter configuration, and rather than requiring a utility to store many different meters in inventory, only two sets of meters need be on hand for socket based applications, for example. These meters are readily and easily configurable so that accurate metering is performed at each
5 installation.

Brief Description of the Drawings

Figure 1 is a block diagram of an electronic energy meter.

Figure 2 is a block diagram illustration of the digital signal processor shown in Figure 1.

10 Figure 3 is a chart illustrating the form, elements, and methods of operation for a variety of electricity services.

Figure 4a is a matrix illustrating the processing steps executed by the digital signal processor for each of the various forms identified in Figure 3, and Figures 4b and 4c illustrate various meter forms and designations referenced in
15 the matrix shown in Figure 4a.

Figure 5 is a chart setting forth additional metering applications, digital signal processor input signals, form, and processing steps executed by the processor.

20 Figures 6a-i illustrate electrical connections made for various forms and applications.

Detailed Description

Figure 1 is a block diagram illustration of an exemplary electronic energy meter 10 which, for example, is commercially available from General Electric Company, 130 Main Street, Somersworth, N.H. 03878, and generally
25 referred to as the KV meter. The KV meter can be modified to be configurable as described below in more detail. Although the present apparatus and methods are described herein in the context of an electronic electricity meter, it should be understood that the present invention is not limited to practice with any one

-5-

particular meter. The present invention can be utilized in connection with other microcomputer based meters.

Referring now specifically to Figure 1, meter 10 includes voltage sensors 12 and current sensors 14. Sensors 12 and 14, in operation, typically are coupled to the power lines supplying power to site at which the meter is located. Sensors 12 and 14 are coupled to an analog to digital (A/D) converter 16 which converts the input analog voltage and current signal to digital signals. The output of converter 16 is provided to a digital signal processor (DSP) 18. DSP 18 supplies microcomputer 20 with digitized metering quantities, e.g., V^2H , I^2H . Microcomputer 20, using the metering quantities supplied by DSP 18, performs additional metering calculations and functions. DSP 18 may, for example, be a processor commercially available as Model Number TMS320 from Texas Instruments Company, P.O. Box 6102, Mail Station 3244, Temple, TX 76503, modified to perform metering functions.

Microcomputer 20 is coupled to a liquid crystal display 22 to control the display of various selected metering quantities and to an optical communications port 24 to enable an external reader to communicate with computer 20. Port 24 may be the well known OPTOCOM™ port of General Electric Company, 130 Main Street, Somersworth, N.H. 03878, which is in accordance with the ANSI type II optical port. Microcomputer 20 may also generate additional outputs 26 used for various other functions as is well known in the art. Microcomputer 20 may, for example, be an eight bit microcomputer commercially available from Hitachi America, Inc., Semiconductor & I.C. Division, Hitachi Plaza, 2000 Sierra Point Parkway, Brisbane, CA 94005-1819, modified to perform metering functions.

Microcomputer 20 also is coupled to an input/output (I/O) board 28 and to a function, or high function, board 30. DSP 18 also supplies outputs directly to high function board 30. Microcomputer 20 further is coupled, via a control bus 32, to an electronically erasable programmable read only memory

-6-

(EEPROM) 34. I/O board 28 and high function board 30 also are coupled, via bus 32, to EEPROM 34.

Back-up power is supplied to the meter components described above by a battery 36 coupled to a wide range power supply 38. In normal operation
5 when no back-up power is required, power is supplied to the meter components from the power lines via power supply 38.

Many functions and modifications of the components described above are well understood in the metering art. The present application is not directed to such understood and known functions and modifications. Rather, the present
10 application is directed to the methods and apparatus for configuring a meter to be compatible with many different metering applications as described below in more detail. In addition, although the methods and apparatus are described below in the hardware environment shown in connection with Figure 1, it should be understood that such methods and apparatus are not limited to practice
15 in such environment. The subject methods and apparatus could be practiced in many other environments.

Further, it should be understood that the present invention can be practiced with many alternative microcomputers, and is not limited to practice in connection with just microcomputer 20. Therefore, and as used herein, the
20 term microcomputer is not limited to mean just those integrated circuits referred to in the art as microcomputers, but broadly refers to microcomputers, processors, microcontrollers, application specific integrated circuits, and other programmable circuits.

Figure 2 is a block diagram illustration of DSP 18 shown in Figure 1.
25 DSP 18 includes a random access memory (RAM) 50 illustrated as being a 512 byte RAM. Inputs to DSP 18 includes sample sets from A/D converter 16 which are transmitted from converter 16 to DSP 18 at 3900 bits per second in the specific configuration illustrated. The sample sets are at least temporarily stored in RAM 50 for further processing. DSP 18 also includes a read only
30 memory (ROM), and a number of instructions (FL and PF) 52 and metering

-7-

pulse instruction (Kt) 54, and instruction sets 56 and 58 are stored in the ROM. Block 56 describes the values calculated by DSP 18 as being V^2 , Reactive Power, I^2 , Active Power, and Imputed Neutral I^2 , for fundamental and harmonics. Block 58 describes values calculated by DSP 18 for 50 or 60 Hz NB Filter, V^2 , Reactive Power, zero crossing (0 X), and Active Power, for fundamental frequency only. The settings for various flags and accumulated values 60 also are stored in the ROM.

As described above, DSP 18 is configured to connect to microcomputer 20, and such connection is made via a serial input/output port 62. Various commands and data are passed between DSP 18 and microcomputer 20 via port 62, and such commands and data include adjustments for 50 Hz and 60 Hz operation, diagnostics, flags, metering constant (Kt), measurements, selected samples and counts, and verifications. These commands and data are stored at least temporarily in RAM 50 and are used to control processing by DSP 18. DSP 18 also includes a reset port 64, and when a reset signal is received at reset port 64, various checks are performed including ROM and analog-to-digital converter tests, as is known in the art.

DSP 18 is described herein as one exemplary embodiment of the environment in which the present invention can be practiced. It should be understood, therefore, that the present invention can be practiced in connection with many alternative types of processors and in other meter configurations.

Generally, and with respect to operation of DSP 18, instruction sets include processing steps to be executed to determine line voltages and line currents for respective meter form types are stored in the DSP memory, or ROM. Microcomputer 20 is operable to transmit a selection command to DSP 18 to control selection of one of the instruction sets stored in the DSP memory. Particularly, microcomputer 20 is configured to receive a control command via optical port 24, and microcomputer 20 uses the control command to generate the selection command. DSP 18 then processes the data received from ADC 16 in accordance with the selected instruction set, and the calculated values are

provided to microcomputer 20 via serial I/O 62. In addition, DSP 18 can be programmed to calibrate the samples received from ADC 16, and such calibrated samples can be provided to other meter circuitry via a DSP bus.

5 With respect to function blocks 56 and 58, the underlying process steps executed by DSP 18 to make calculations such as reactive power and active power are dependent upon the meter form and the electrical circuit in which the meter is connected. More particularly, and referring to Figure 3, the meter form types includes meter ANSI form 9 and meter ANSI form 16 type forms, the number of elements may be 3, 2, 2 1/2, or 1, and there are a number of
10 circuit configurations in which the meter can be connected. The meter form, elements, and circuit configurations affect the inputs received by the DSP and the meter operation. The meter method of operation (MO) designations in accordance with ANSI standards are set forth in Figure 3.

Figure 4a illustrates the processing steps executed by DSP 18 for each
15 of the various forms and meter operation (MO) designations identified in Figure 3. The designations set forth in Figure 4a correspond to the meter base forms illustrated in Figures 4b and 4c. Particularly, Figure 4b is a form 9S meter base and Figure 4c is a form 16S meter base. Each voltage is the potential difference between the voltage sensing blades which are illustrated as solid
20 rectangles in Figures 4b and 4c. Each voltage sensing blade is assigned a number, i.e., 0, 1, 2, 3. Each current is sensed in a conductive circuit between two blades, illustrated in Figures 4b and 4c as a line between blades. The current sensing blades are illustrated as outlined rectangles. Each current is designated as a letter A, B, or C. Some socket type meters have blades which
25 are utilized for both voltage sensing and current sensing. This circumstance is illustrated in Figures 4b and 4c with one blade (e.g., an upper blade) illustrated as a voltage sensing blade with a number (e.g., 1, 2, or 3) next to it and a lower blade illustrated as a current sensing blade.

Referring now to Figures 4a, 4b, and 4c, the values e_0 , e_1 , e_2 , and e_3
30 represent the voltage signal values obtained from respective voltage sensing

-9-

blades of the meter base and provided to DSP 18 via ADC 16. The values e_A , e_B , and e_C are the calculated voltage values for the respective lines, and the values i_A , i_B , and i_C are the calculated current values for the respective lines. Using the voltage values, instantaneous power can be calculated in accordance with the following.

$$p_A = e_A \times i_A,$$

$$p_B = e_B \times i_B,$$

$$p_C = e_C \times i_C, \text{ and}$$

$$P_{TOTAL} = p_A + p_B + p_C.$$

As set forth in Figure 3, the calculations for each the various voltage and current values may vary depending on the meter form and meter operation.

Figure 5 is a chart setting forth in more detail the DSP processing steps for each type of meter service application. The DSP Case # column refers to the general designation which may be assigned to each meter application. The DSP Case # could be used, for example, by microcomputer 20 to communicate to DSP 18 the particular type of service being metered so that DSP 18 executes the appropriate steps in calculating the various metering quantities. More particularly, and in one specific embodiment, the DSP Case # is passed to DSP 18 from microcomputer 20 in a configuration word (CFG_WRD).

The Meter Application column identifies the specific electric circuit being metered. For example, for DSP Case # 0, the specific meter being used is a 2-element, 3-wire meter in a 3-phase, 3-wire delta service. The DSP input signals column identifies the signals provided to DSP 18 from ADC 16. The ANSI forms column identifies the particular ANSI form corresponding to the particular service. The Symmetrical column identifies whether the attributes of symmetry (i.e., whether arithmetic apparent power is defined) are present.

The Processing Steps column identifies the processing carried out by DSP 18 to calculate various metering quantities for each DSP Case #. Execution of the steps shown in Figure 5 for each case are to be carried out from top to bottom, and the processing is performed on corrected samples to

-10-

transform a wide variety of forms and services into a virtual 4-wire wye configuration.

Of course, the present invention is not limited to the specific processing steps illustrated in Figure 5, and it is possible to use other processing steps even
5 for the same meter applications depending on the standard calculation methodology selected. For example, in the processing illustrated in Figure 5 and as explained above, the processing is performed to transform a wide variety of forms and services into a virtual 4-wire wye configuration. Of course, in making this transformation, some of the phases do not actually exist and are
10 processed as phantom phases. Alternatively, the processing could be carried out to transform the data to some other virtual meter configuration.

Figures 6a-i illustrate electrical connections made for various forms and applications. Generally, using the present invention, two meter forms satisfy all electrical services requiring three or fewer meter elements. Particularly,
15 with class 20 and class 200 meter forms rated at 57 to 120 volts, and 120 to 480 volts accommodating 528 volts continuously and 575 volts maximum, such service needs can be met with just two meter forms. In addition, with an extended class 320 rated meter, load currents up to 320 amperes directly can be metered. Using a form 9S, class 20 meter with instrument transformers, larger
20 loads and higher voltages can be measured.

More particularly, and referring to Figures 6a-i, the form designations are set forth in accordance with ANSI C12.10 form designations. Figure 6a-c illustrate self-contained, form 16S meter bases with the following ratings: Kh 21.6, Kt 4.5, and CL 320. Figure 6a is a 2-wire base, Figure 6b is a 3-wire
25 base, and Figure 6c is a 4-wire base. Figures 6d-i illustrate transformer rated, form 9S meter bases with the following ratings: Kh 1.8, Kt 0.3, and CL 20. Current transformers are identified by the designation "CT" and voltage transformers are identified by the designation "VT". The meter base connections illustrated in Figures 6d-f include current transformer(s) (CT) only,

-11-

and the meter base connections illustrated in Figure 6g-i include current transformer(s) (CT) and voltage transformer(s) (VT).

When fabricating the above described meter including DSP 18, a meter base is selected at the factory. As is known in the art, and by way of example with respect to meter socket types, the meter base configuration may conform to the ANSI 9S socket configuration or the ANSI 16S socket configuration. Depending on the meter base configuration, the DSP memory is then loaded with instruction sets for all possible applications for that particular base. For example, a meter having a base which conforms to an ANSI 9S socket may have a 3 element, a 2 1/2 element, a 2 element, or a 1 element connection between the meter and the power lines. In addition, and for each of the various number of elements, the specific electric circuit to which meter is actually used depends upon the electric service, e.g., an ANSI 9S form, 3 element connection may be electrically connected to a 4W-Y configuration or a 4W-delta configuration. The instructions sets which reside in the DSP memory contain the process steps to be executed for each of the possible applications for the particular meter base. The meter is preprogrammed at the factory so that the most commonly used instruction set for the meter base is selected for execution by the DSP, and the meter is then delivered to the utility.

At the utility, and for an ANSI 9S base meter for example, a worker may install the meter in any ANSI 9S socket. If the electric connection between the meter and the power lines at that particular installation correspond to the preprogrammed selected instruction set, then the worker need not take any further action with respect to proper installation. If the particular installation does not correspond to the preprogrammed selected instruction set, the worker may then select the appropriate instruction set by transmitting a select signal to the microcomputer via the optical port. The microcomputer then transmits the command signal to the DSP instructing the DSP to execute a particular preloaded instruction set corresponding the electric circuit at the installation.

-12-

With the above described meter configuration, and rather than requiring a utility to store many different meters in inventory, only two sets of meters need be on hand for socket based applications, for example. These meters are readily and easily configurable so that accurate metering is performed at each
5 installation.

From the preceding description of various embodiments of the present invention, it is evident that the objects of the invention are attained. Although the invention has been described and illustrated in detail, it is to be clearly understood that the same is intended by way of illustration and example only
10 and is not to be taken by way of limitation. For example, it is contemplated that the DSP could be automatically configured for a particular service rather than requiring a user to select the DSP Case Number. Particularly, depending on the particular service and using predetermined criteria, the microcomputer could automatically determine the type of service being metered and then
15 instruct the DSP to execute the appropriate instruction sets. As an example, if DSP Case Number 3 is selected for a form 45S, 2 element, 3 wire meter, several different services could be metered. Upon initiation of operation, the microcomputer may determine, using preprogrammed criteria, that DSP Case Number 0 is the correct case number, and the DSP would automatically be
20 instructed by the microcomputer to execute the instruction sets for DSP Case Number 0. Accordingly, the spirit and scope of the invention are to be limited only by the terms of the appended claims.

Claims:

1. An electricity meter for measuring energy consumption of a load, comprising:
 - voltage and current sensor for generating signals representative of current and voltage at the load;
- 5 a digital signal processor coupled to said voltage and current sensors, said digital signal processor comprising a memory having stored therein a plurality of selectable instruction sets corresponding to respective meter form types.
2. An electricity meter in accordance with Claim 1 wherein said meter further comprises a microcomputer coupled to said digital signal processor for receiving data therefrom, said microcomputer operable transmit a selection command to said digital signal processor to control selection of one
- 5 of said instruction sets stored in said digital signal processor memory.
3. An electricity meter in accordance with Claim 2 further comprising an optical port electrically coupled to said microcomputer, said microcomputer configured to receive a control command from said optical port and using the control command, generate the selection command.
4. An electricity meter in accordance with Claim 1 wherein the form types includes meter ANSI form 9 and meter ANSI form 16 type forms.
5. An electricity meter in accordance with Claim 1 wherein the instruction sets include processing steps to be executed to determine line voltages and line currents for respective meter form types.

6. A processor for an electricity meter, said processor comprising:
a memory having stored therein a plurality of selectable instruction sets corresponding to respective meter form types; and
a processing unit for performing energy consumption calculations, said
5 processing unit configured to execute a selected one of said instruction sets so that said energy consumption calculations are performed in accordance with a respective one of the meter form types.
7. A processor in accordance with Claim 6 comprising an input configured to be coupled to a microcomputer operable transmit a selection command to said digital signal processor to control selection of one of said instruction sets stored in said digital signal processor memory.
8. A processor in accordance with Claim 6 wherein the form types includes meter ANSI form 9 and meter ANSI form 16 type forms.
9. A processor in accordance with Claim 6 wherein the instruction sets include processing steps to be executed to determine line voltages and line currents for respective meter form types.

-15-

10. A method of operating a meter for measuring energy consumption of a load, the meter including voltage and current sensors for generating signals representative of current and voltage at the load, and a digital signal processor coupled to the voltage and current sensors, the digital signal processor including a memory having stored therein a plurality of selectable instruction sets corresponding to respective meter form types, said method comprising the steps of:

5 selecting at least one of the instructions sets for execution; and
executing the instructions contained in the selected instruction set.

11. A method in accordance with Claim 10 wherein the meter further includes a microcomputer coupled to the digital signal processor for receiving data therefrom, the microcomputer operable transmit a selection command to the digital signal processor to control selection of one of the instruction sets stored
5 in the digital signal processor memory.

12. A method in accordance with Claim 11 further wherein the meter further includes an optical port electrically coupled to the microcomputer, the microcomputer configured to receive a control command from the optical port and using the control command, generate the selection command.

13. A method in accordance with Claim 10 wherein the form types includes meter ANSI form 9 and meter ANSI form 16 type forms.

14. A method in accordance with Claim 10 wherein the instruction sets include processing steps to be executed to determine line voltages and line currents for respective meter form types.

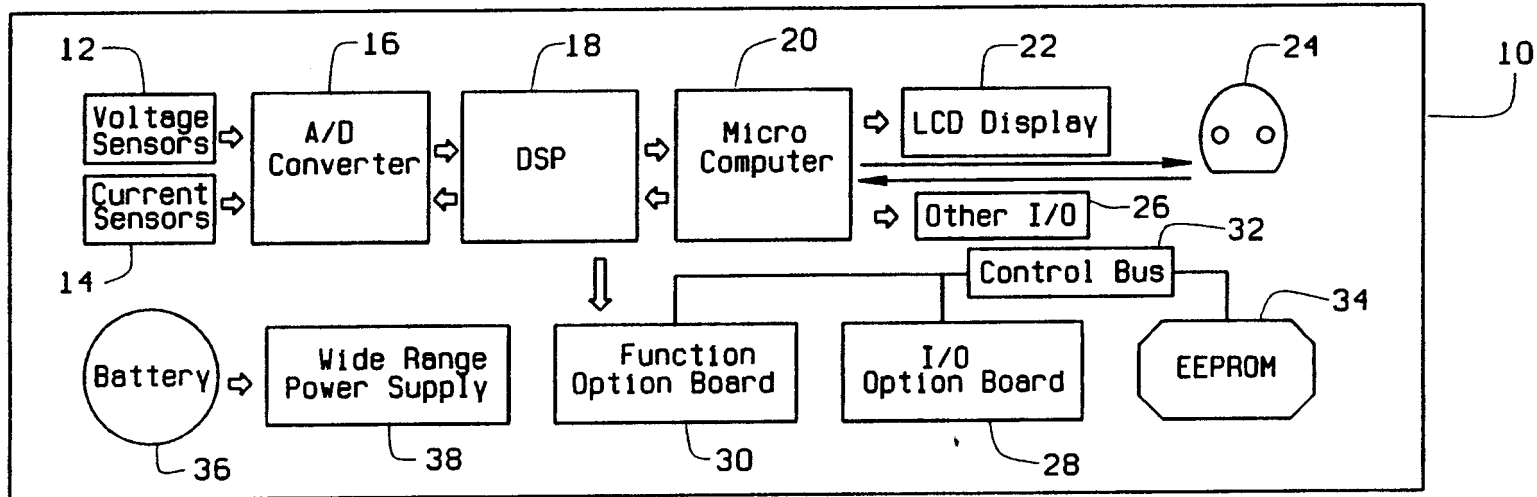

FIG. 1

FORM	ELE	4W-Y	4W-Δ	3W-Δ	3W-NETWORK	3W-1Φ	2W-1Φ
9	3	MO 9-6	MO 9-6				
9	2-1/2	MO 36-2					
9	2	MO 45-4	MO 45-3	MO 45-0		MO 45-4	
9 OR 16	1					MO 2-1	MO 3-5
16	2			MO 12-0	MO 12-4	MO 12-4	
16	3	MO 16-6	MO 16-6				

FIG. 3

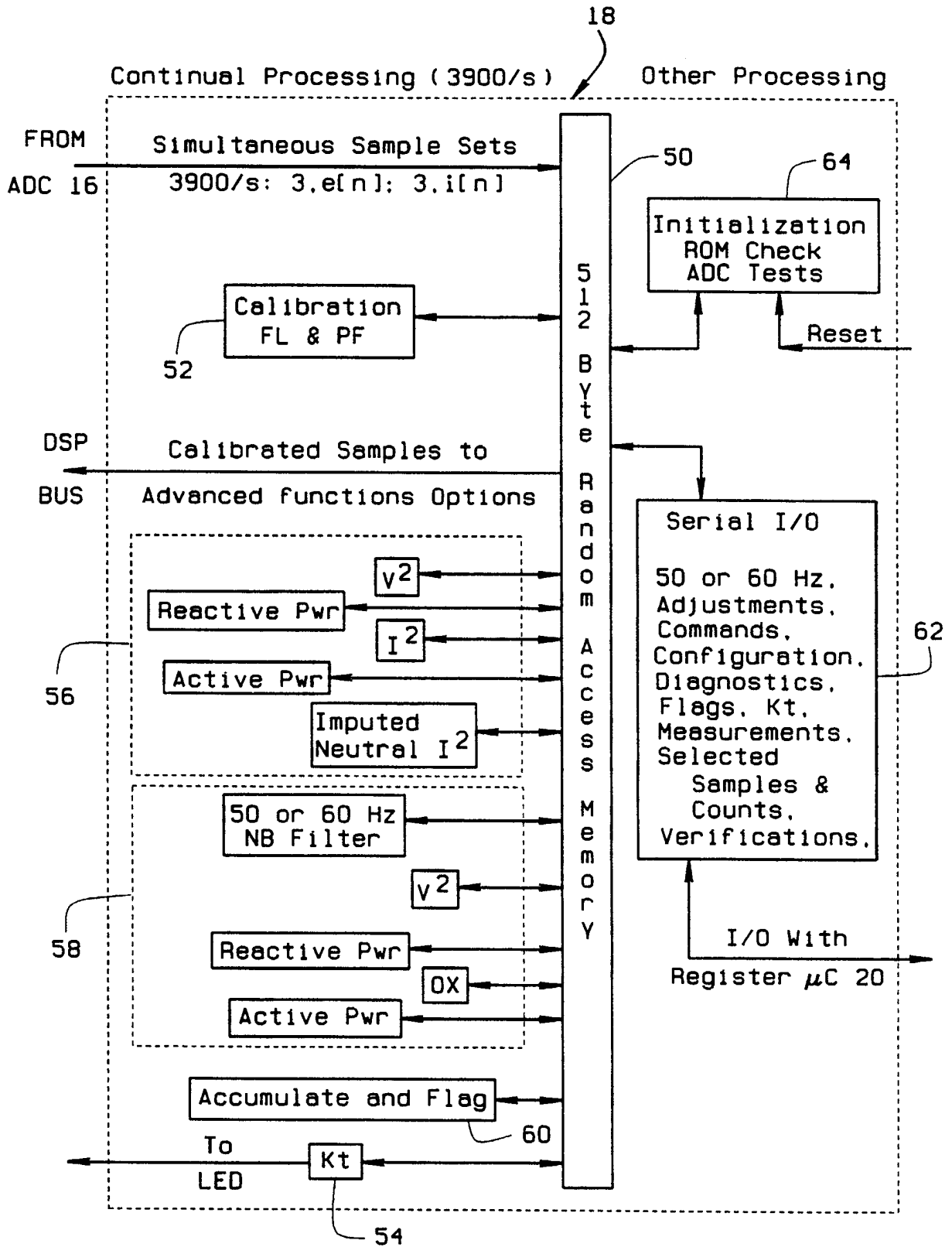

FIG. 2

9	MO 45-0	$e_A = \{2(e_1 - e_0) - (e_3 - e_0)\} / 3$	$e_B = -(e_1 - e_0) + (e_3 - e_0) / 3$
16	MO 12-0	$e_C = \{2(e_3 - e_0) - (e_1 - e_0)\} / 3$	$1_B = -(1_A + 1_C)$
9816	MO 2-1	$e_A = (e_1 - e_0) / 2$	$e_B = 0$
9	MO 36-2	$e_A = e_1 - e_0$	$e_B = -(e_1 - e_0) + (e_3 - e_0)$
9	MO 45-3	$e_A = (e_1 - e_0) - (e_2 - e_0)$	$e_B = 0$
9816	MO 45&12-4	$e_A = e_1 - e_0$	$e_B = 0$
9816	MO3-5	$e_A = e_1 - e_0$	$e_B = 0$
9816	MO9&16-6	$e_A = e_1 - e_0$	$e_B = e_2 - e_0$

FIG. 4a

39 / 51

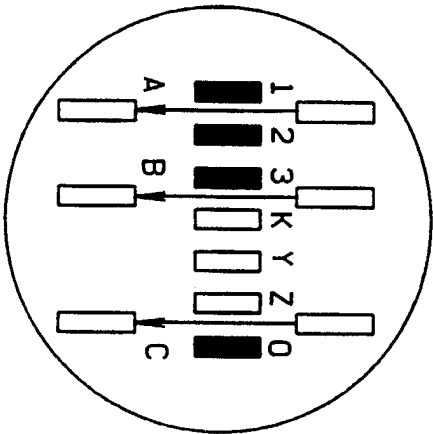

FIG. 4b

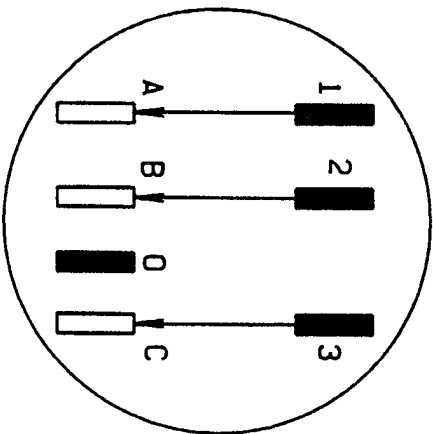

FIG. 4c

DSP Case #	Meter Applications	DSP Input Signals	ANSI Forms	Symmetrical	Processing Steps
0	2-element, 3-wire meter 3-phase, 3-wire delta service	Va, Ia, Vc, Ic	12S 45S	yes	$Vb \leftarrow -1/3(Va+Vc)$ $Va \leftarrow Vb+Va$ $Vc \leftarrow Vb+Vc$ $Ib \leftarrow -(Ia+Ic)$
1	1-element, 3-wire meter 1-phase, 3-wire service	Va, Ia, Ic	2S	yes	$Vc \leftarrow -Va/2$ $Va \leftarrow Va+Vc$ $Vb \leftarrow 0, Ib \leftarrow 0$
2	2-1/2 element, 4-wire meter 3-phase, 4-wire wye service	Va, Ia, Ib, Vc, Ic (Vb absent)	36S	yes	$Vb \leftarrow -(Va+Vc)$
3	2-element, 3-wire meter 3-phase, 4-wire delta service 1-phase, 3-wire service, 3-phase, 4-wire wye service	Va, Ia, Vb, Vc, Ic.	45S	no yes yes	$Va \leftarrow Va-Vb$ $Vb \leftarrow 0$ $Ib \leftarrow 0$
4	2-element, 3-wire meter 1-phase, 3-wire service, network service	Va, Ia, Vc, Ic	12S	yes no	$Vb \leftarrow 0, Ib \leftarrow 0$
5	1-element, 2-wire meter 1-phase, 2-wire service	Va, Ia	3S		$Vb \leftarrow 0, Vc \leftarrow 0,$ $Ib \leftarrow 0, Ic \leftarrow 0$
6	3-element, 4-wire meter 3-phase/4-wire (wye) 3-phase, 4-wire delta service	Va, Ia, Vb, Ib, Vc, Ic	9S 16S	yes no	none

FIG. 5

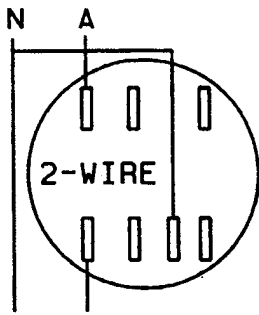

FIG. 6a

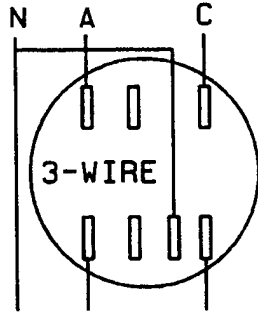

FIG. 6b

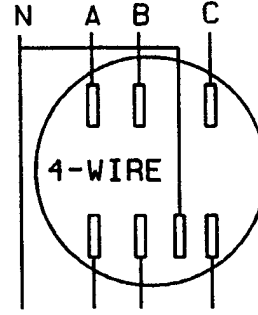

FIG. 6c

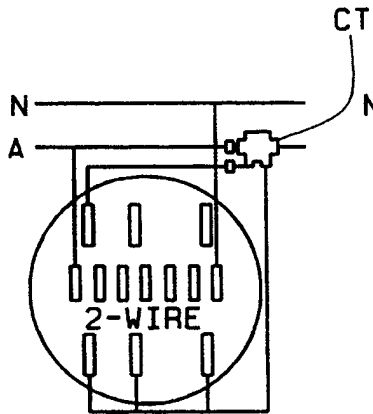

FIG. 6d

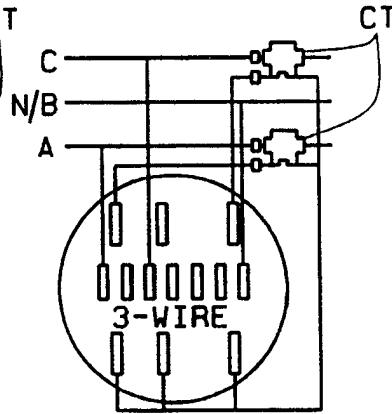

FIG. 6e

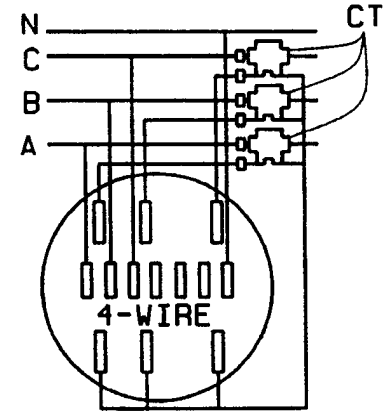

FIG. 6f

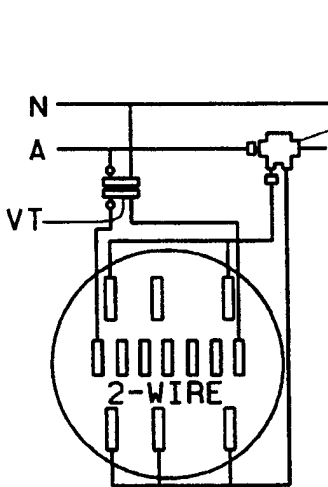

FIG. 6g

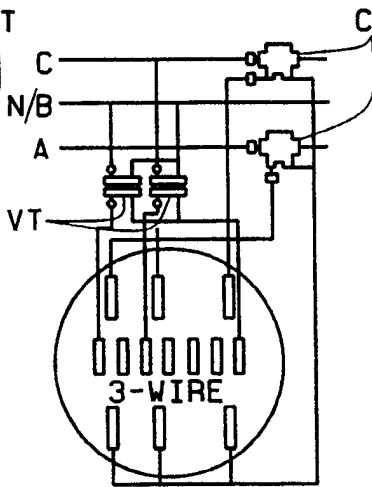

FIG. 6h

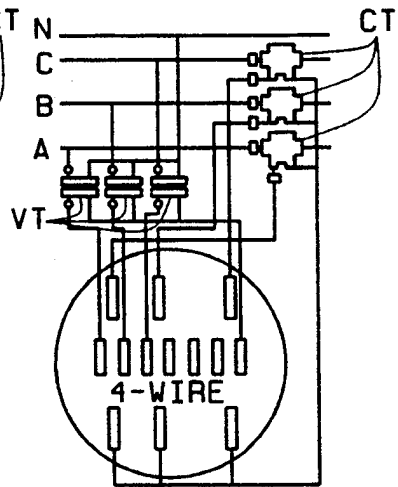

FIG. 6i

INTERNATIONAL SEARCH REPORT

International Application No
PCT/US 98/09555

A. CLASSIFICATION OF SUBJECT MATTER
IPC 6 G01R21/133

According to International Patent Classification (IPC) or to both national classification and IPC

B. FIELDS SEARCHED
Minimum documentation searched (classification system followed by classification symbols)
IPC 6 G01R

Documentation searched other than minimum documentation to the extent that such documents are included in the fields searched

Electronic data base consulted during the international search (name of data base and, where practical, search terms used)

C. DOCUMENTS CONSIDERED TO BE RELEVANT

Category	Citation of document, with indication, where appropriate, of the relevant passages	Relevant to claim No.
X	US 5 555 508 A (MUNDAY MARK L ET AL) 10 September 1996 see abstract	1, 2, 5-7, 9-11, 14
Y	see column 4, line 14 - line 31 see column 4, line 39 - column 5, line 5 see column 9, line 36 - line 39	3, 12
A	see figures 1, 2	4, 8, 13
X	---	
X	US 5 548 527 A (HEMMINGER RODNEY C ET AL) 20 August 1996 see abstract	1, 2, 5-7, 9-11, 14
Y	---	
Y	US 4 884 021 A (HAMMOND SCOTT H ET AL) 28 November 1989 see abstract see column 7, line 23 - line 63 see figure 1	3, 12

	-/--	

Further documents are listed in the continuation of box C. Patent family members are listed in annex.

Special categories of cited documents :

<p>"A" document defining the general state of the art which is not considered to be of particular relevance</p> <p>"E" earlier document but published on or after the international filing date</p> <p>"L" document which may throw doubts on priority claim(s) or which is cited to establish the publication date of another citation or other special reason (as specified)</p> <p>"O" document referring to an oral disclosure, use, exhibition or other means</p> <p>"P" document published prior to the international filing date but later than the priority date claimed</p>	<p>"T" later document published after the international filing date or priority date and not in conflict with the application but cited to understand the principle or theory underlying the invention</p> <p>"X" document of particular relevance; the claimed invention cannot be considered novel or cannot be considered to involve an inventive step when the document is taken alone</p> <p>"Y" document of particular relevance; the claimed invention cannot be considered to involve an inventive step when the document is combined with one or more other such documents, such combination being obvious to a person skilled in the art.</p> <p>"&" document member of the same patent family</p>
--	--

Date of the actual completion of the international search 10 August 1998	Date of mailing of the international search report 17/08/1998
--	---

Name and mailing address of the ISA European Patent Office, P.B. 5818 Patentlaan 2 NL - 2280 HV Rijswijk Tel. (+31-70) 340-2040, Tx. 31 651 epo nl, Fax: (+31-70) 340-3016	Authorized officer Lopez-Carrasco, A
--	--

INTERNATIONAL SEARCH REPORT

International Application No
PCT/US 98/09555

C.(Continuation) DOCUMENTS CONSIDERED TO BE RELEVANT		
Category	Citation of document, with indication, where appropriate, of the relevant passages	Relevant to claim No.
A	US 4 754 368 A (BULLOCK DONALD F ET AL) 28 June 1988 see column 1, line 5 - line 24 see column 2, line 43 - line 45 -----	4, 8, 13

INTERNATIONAL SEARCH REPORT

Information on patent family members

International Application No

PCT/US 98/09555

Patent document cited in search report	A	Publication date	Patent family member(s)	Publication date
US 5555508	A	10-09-1996	US 5631843 A	20-05-1997
			US 5544089 A	06-08-1996
			US 5537333 A	16-07-1996
			US 5548527 A	20-08-1996
			AU 3130193 A	13-09-1993
			BR 9207088 A	26-12-1995
			CA 2130433 A	02-09-1993
			CN 1079305 A	08-12-1993
			EP 0671009 A	13-09-1995
			MX 9206230 A	01-09-1993
			WO 9317390 A	02-09-1993
US 5548527	A	20-08-1996	US 5544089 A	06-08-1996
			US 5537333 A	16-07-1996
			US 5555508 A	10-09-1996
			US 5631843 A	20-05-1997
			AU 3130193 A	13-09-1993
			BR 9207088 A	26-12-1995
			CA 2130433 A	02-09-1993
			CN 1079305 A	08-12-1993
			EP 0671009 A	13-09-1995
			MX 9206230 A	01-09-1993
			WO 9317390 A	02-09-1993
US 4884021	A	28-11-1989	CA 1290400 A	08-10-1991
			EP 0288413 A	26-10-1988
US 4754368	A	28-06-1988	CA 1285026 A	18-06-1991