



(51) International Patent Classification:
A61M 5/32 (2006.01)

(21) International Application Number:

PCT/US2013/029518

(22) International Filing Date:

7 March 2013 (07.03.2013)

(25) Filing Language:

English

(26) Publication Language:

English

(30) Priority Data:

61/607,711 7 March 2012 (07.03.2012) US

(71) Applicant: WEST PHARMACEUTICAL SERVICES, INC. [US/US]; 530 Herman O. West Drive, Exton, PA 19341 (US).

(72) Inventors: EVANS, Christopher; 19 Health Lane, Long Valley, NJ 07853 (US). COSTELLO, Brian; 114 Locust Drive, Union, NJ 07083 (US). GIEDA, Christopher; 19 Valley View Road, Long Valley, NJ 07853 (US).

(74) Agents: HSING, Weihong et al.; Panitch Schwarze Belisario & Nadel LLP, One Commerce Square, 2005 Market Street, Suite 2200, Philadelphia, PA 19103 (US).

(81) Designated States (unless otherwise indicated, for every kind of national protection available): AE, AG, AL, AM, AO, AT, AU, AZ, BA, BB, BG, BH, BN, BR, BW, BY, BZ, CA, CH, CL, CN, CO, CR, CU, CZ, DE, DK, DM, DO, DZ, EC, EE, EG, ES, FI, GB, GD, GE, GH, GM, GT, HN, HR, HU, ID, IL, IN, IS, JP, KE, KG, KM, KN, KP, KR, KZ, LA, LC, LK, LR, LS, LT, LU, LY, MA, MD, ME, MG, MK, MN, MW, MX, MY, MZ, NA, NG, NI, NO, NZ, OM, PA, PE, PG, PH, PL, PT, QA, RO, RS, RU, RW, SC, SD, SE, SG, SK, SL, SM, ST, SV, SY, TH, TJ, TM, TN, TR, TT, TZ, UA, UG, US, UZ, VC, VN, ZA, ZM, ZW.

(84) Designated States (unless otherwise indicated, for every kind of regional protection available): ARIPO (BW, GH, GM, KE, LR, LS, MW, MZ, NA, RW, SD, SL, SZ, TZ, UG, ZM, ZW), Eurasian (AM, AZ, BY, KG, KZ, RU, TJ, TM), European (AL, AT, BE, BG, CH, CY, CZ, DE, DK, EE, ES, FI, FR, GB, GR, HR, HU, IE, IS, IT, LT, LU, LV,

[Continued on next page]

(54) Title: LOW RADIAL PROFILE NEEDLE SAFETY DEVICE

(57) Abstract: A needle safety device (1) has an outer tube (10) within which a syringe barrel (2) is slideably receivable. A collar (14) in the outer tube (10) is moveable relative thereto and rotatably attachable to the distal end of the barrel (2). A force member (16) biases the outer tube (10) in a distal direction. A track (S) is formed in the inner surface of the outer tube (10). A pin (18) extending radially outwardly from the collar (14) slidingly engages the track (S). In a staging position, the barrel is inspectable. In a pre-injection position, the cannula extends a first length beyond the outer tube. In a full-insertion position, the cannula extends a second length greater than the first length beyond the outer tube. In a locked position, the cannula is entirely within the outer tube.

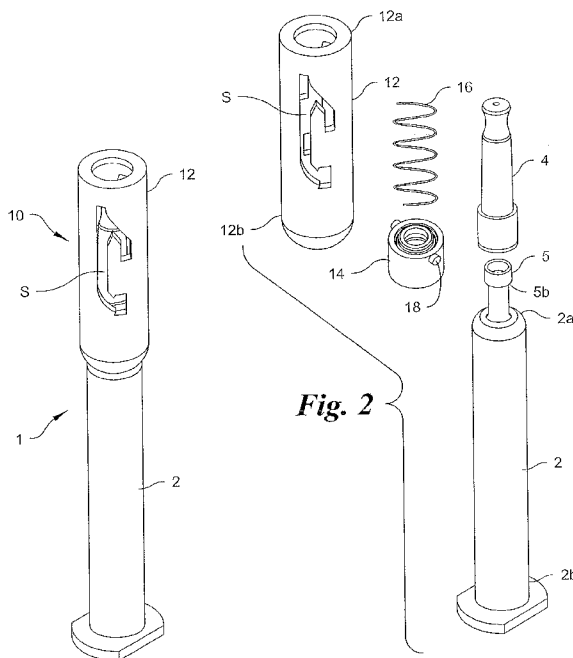
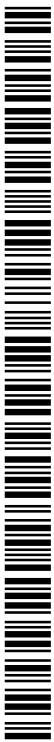

Fig. 1

Fig. 2



MC, MK, MT, NL, NO, PL, PT, RO, RS, SE, SI, SK, **Published:**
SM, TR), OAPI (BF, BJ, CF, CG, CI, CM, GA, GN, GQ, — *with international search report (Art. 21(3))*
GW, ML, MR, NE, SN, TD, TG).

TITLE OF THE INVENTION

[0001] Low Radial Profile Needle Safety Device

CROSS-REFERENCE TO RELATED APPLICATIONS

[0002] This application is related to U.S. Provisional Patent Application No. 61/607,711,
5 filed March 7, 2012 and claims the earlier filing dates of the provisional application which is
incorporated in the entirety herein by reference.

BACKGROUND OF THE INVENTION

[0003] The present invention is directed to a low radial profile needle safety shield for
syringes, in general, and for pharmaceutical syringes in particular.

10 [0004] Needlestick injuries are a well known occupational hazard for healthcare workers.
Unintended needlesticks have the potential for transmitting blood-borne viruses such as hepatitis
B and C and the human immunodeficiency virus (HIV) to the recipient. After a needlestick
injury, certain procedures must be followed to minimize the risk of infection for the recipient,
such as laboratory blood tests and post-exposure prophylaxis started immediately after exposure
15 to a pathogen, such as one of the aforementioned viruses, in order to prevent infection by the
pathogen and the development of the associated disease.

[0005] Conventional safety devices intended to reduce the frequency of post-injection
needlesticks typically have a sheath partially or completely surrounding the pharmaceutical
syringe. The sheath may be held in a retracted position exposing the needle for aspiration and
20 injection and may be automatically deployed around a needle afterwards.

[0006] Among the drawbacks of many conventional prior art needle safety devices is that
they are not compatible with current accepted practice due to sizes and configurations that are
incompatible with conventional filling and sterilization equipment and methods.

[0007] Accordingly, there is a need in the art for a safety injection device having a low
25 radial profile.

BRIEF SUMMARY OF THE INVENTION

Briefly stated, one aspect of the invention is a needle safety device for an injection
device having a generally cylindrical barrel with a distal end from which a cannula extends.
The needle safety device comprises an outer tube within which the barrel is slideably receivable.
30 The outer tube has a distal end and a proximal end. A collar in the outer tube is moveable

relative thereto and is rotatably attachable to the distal end of the barrel. A force member is between the outer tube and the collar and biases the outer tube in a distal direction. A track S is formed in the inner surface of the outer tube. A pin extending radially outwardly from the collar 14 slidably engages the track S. The track S comprises a first track segment extending from a staging position to a pre-injection position. The proximal end of the outer tube is in register with the distal end of the barrel allowing the barrel to be inspected when the collar is attached to the distal end of the barrel and the pin is in the staging position. The cannula extends a first length beyond the distal end of the outer tube when the collar is attached to the distal end of the barrel and the pin is in the pre-injection position. A second track segment contiguous with the first track segment extends from the pre-injection position to a full-insertion position. The cannula extends a second length greater than the first length from the distal end of the outer tube when the collar is attached to the distal end of the barrel and the pin is in the full-insertion position. A third track segment contiguous with the second track segment extends from the full-insertion position to a locked position in which the pin is immovably retainable. The cannula is entirely within the outer tube when the collar is attached to the distal end of the barrel and the pin is immovably retained in the locked position.

BRIEF DESCRIPTION OF THE SEVERAL VIEWS OF THE DRAWINGS

[0008] The foregoing summary, as well as the following detailed description of preferred embodiments of the invention, will be better understood when read in conjunction with the appended drawings. For the purpose of illustrating the invention, there is shown in the drawings embodiments which are presently preferred. It should be understood, however, that the invention is not limited to the precise arrangements and instrumentalities shown.

[0009] In the drawings:

[0010] Fig. 1 is a side perspective view of an embodiment of the low radial-profile needle safety device in a staging position on the barrel of a pharmaceutical injection device in accordance with the present invention;

[0011] Fig. 2 is an exploded side perspective view of the needle safety device of Fig. 1,

[0012] Fig. 3 is a side cross-sectional view of the safety device of Fig. 1;

[0013] Fig. 4 is a side perspective view of the outer tube of the safety device of Fig. 1;

[0014] Figs. 5 and 6 are side cross-sectional views of the outer tube of the safety device of Fig. 1 showing the track in the outer tube;

[0015] Fig. 7 is a top perspective view of the collar of the safety of Fig.1;

[0016] Fig. 8 is a side perspective view of another embodiment of the low radial-profile needle safety device in a staging position on the barrel of a pharmaceutical injection device in accordance with the present invention;

[0017] Fig. 9 is an exploded side perspective view of the needle safety device of Fig. 8,

5 [0018] Fig. 10 is an side cross-sectional view of the safety device of Fig. 8;

[0019] Fig. 11 is a front elevation view of the outer tube of the safety device of Fig. 8;

[0020] Fig. 12 is a right side elevation view of the outer tube of the safety device of Fig. 8;

[0021] Figs. 13A and 13B are side cross-sectional views of the outer tube of the safety device of Fig.8;

10 [0022] Fig. 14 is a top plan view of the collar of Fig. 8; and

[0023] Figs. 15A-15D is a sequence of side elevation views of the safety device and a portion of a pharmaceutical syringe of Fig. 1 showing progressive positions of the safety device relative to the pharmaceutical insertion device.

DETAILED DESCRIPTION OF THE INVENTION

15 [0024] Reference will now be made in detail to embodiments of the invention, examples of which are illustrated in the accompanying drawings. The terminology used in the description of the invention herein is for the purpose of describing particular embodiments only and is not intended to be limiting of the invention.

[0025] As used in the description of the invention and the appended claims, the singular
20 forms “a”, “an” and “the” are intended to include the plural forms as well, unless the context clearly indicates otherwise. The words “and/or” as used herein refers to and encompasses any and all possible combinations of one or more of the associated listed items. The words “comprises” and/or “comprising,” when used in this specification, specify the presence of stated
25 features, integers, steps, operations, elements, and/or components, but do not preclude the presence or addition of one or more other features, integers, steps, operations, elements, components, and/or groups thereof.

[0026] The words “right,” “left,” “lower” and “upper” designate directions in the drawings to which reference is made. The words “inwardly” and “outwardly” refer to directions toward and away from, respectively, the geometric center of the needle safety shield, and designated
30 parts thereof. The terminology includes the words noted above, derivatives thereof and words of similar import.

[0027] Although the words first, second, *etc.*, are used herein to describe various elements, these elements should not be limited by these words. These words are only used to distinguish one element from another. For example, a first segment could be termed a second segment, and, similarly, a second segment could be termed a first segment, without departing from the scope
5 of the present invention.

[0028] As used herein, the word “distal” means in a direction away from the hand of a user holding the injection device immediately prior to injecting a medicament (*e.g.*, the end of the barrel from which the cannula extends is the distal end of the barrel) and “proximal” means toward the hand of a user holding the injection device immediately prior to injecting a
10 medicament.

[0029] The following descriptions are directed towards various embodiments of a needle safety shield in accordance with the present invention.

[0030] Referring to the drawings in detail, where like numerals indicate like elements throughout, there is shown in Figs. 1-7 a preferred embodiment of a low radial profile needle
15 safety device, generally designated 10, and hereinafter referred to as the “safety device” 10 in accordance with the present invention. The safety device 10 is for use with an injection device 1, such as a pharmaceutical syringe. The injection device 1 may be a pre-filled; however, the present invention is not so limited. For example, the injection device 1 may be nearly any type of pharmaceutical syringe, including those to be filled by a patient or user, for example.

[0031] The injection device 1 preferably has a generally cylindrical barrel 2 having a distal
20 end 2a and an opposing proximal end 2b. A cannula (or needle) 3 extends from the distal end 2a of the barrel 2 and is in fluid communication with a bore of the barrel 2. The cannula 3 may be removably attached to the distal end 2a of the barrel 2. Alternatively, and preferably, the cannula 3 is fixedly attached thereto. A removable shield 4 covers the cannula 3. Typically, the distal end 2a of the barrel 2 is configured as a tapered hub 5 that may have a variety of
25 configurations, such as an inverted frustum, a cylinder or a sphere. Preferably, the hub 5 has a generally circular or bulbous shape that extends radially outwardly or beyond at least some other portion of the distal end 2a of the barrel 2. However, the hub 5 is not limited to the size, shape and/or configuration shown and described herein

[0032] Although the barrel 2 may be formed of nearly any material capable of safely
30 enclosing medicaments, it is preferably formed of glass or a polymeric material. The injection device 1 may be pre-filled with a medicament or may be provided without a medicament for filling by the user.

[0033] A piston rod and piston (not shown) are slidably receivable in the bore of the barrel 2. The piston rod may have a free proximal end that extends from the proximal end of the barrel.

5 [0034] The safety device 10 comprises an outer tube 12 within which the barrel 2 is slideably receivable. The outer tube 12 has a distal end 12a, a proximal end 12b and a longitudinal axis A. A collar 14 is in the outer tube 12 and is movable relative thereto. In some embodiments, the collar 14 is fixedly attachable to the distal end 2a of the barrel 2. In other
10 embodiments, the collar 14 is rotatably attachable to the distal end 2a of the barrel 2. A force member 16, such as a compressible coil spring, is provided between the outer tube 12 and the collar 14. The force member biases the outer tube 12 in a distal direction. A track S is formed
15 in the inner surface of the outer tube 12. A pin 18 extending radially outwardly from the collar 14 slidingly engages the track S which, in turn, guides the movement of the pin 18 and therefore the collar 14 within the outer tube 12.

[0035] Referring to Fig. 7, in a preferred embodiment, the collar 14 has the general shape of
20 a hollow cylinder terminating at the distal end with an annulus 20 having a central bore 22 sized to receive and retain the distal end 2a of the barrel 2 or the hub 5 if the distal end 2a of the barrel 2 is configured as a hub. The annulus 20 is sufficiently compliant and sized to allow passage of the hub 5 through the bore 22 and then to rotatably engage the hub 5. The outer surface of the annulus 20 has a generally circular channel 24 to receive one end of the force member (e.g., a
25 coil spring) 16. A circumferential step 26 (see, Fig. 3) in the inner surface of the outer tube 12 is sized to receive and engage the distal end 14a of the force member 16. At least one pin 18 extends radially outwardly from the collar 18 and is slidably receivable in the track S. In
30 embodiments in which the outer tube 12 has a plurality of tracks, the collar 14 may have a corresponding plurality of pins.

[0036] To mount the collar 14 to the barrel 2, the distal end 2a of the barrel 2 or the hub 5
may be inserted into and through the proximal end 14b of the collar 14 and into and through the
distal end 14a of the collar 14. As the hub 5 passes through the distal end 14a of the collar 14,
the bore 22 in the annulus 20 expands until the hub 5 passes completely therethrough. The
annulus 20 then return to its initial state in which the distal end 14a of the collar 14 abuts the
35 proximal surface 5b of the hub 5, thereby rotatably attaching the collar 14 on the barrel 2
between the hub 5 and a shoulder or enlarged portion of the distal end 2a of the barrel 2.

[0037] Referring to Figs. 5 and 6, in some embodiments, the track S comprises three track
segments. A first track segment S₁ is provided to allow the safety device 10 to be assembled

and inspected after the collar 14 has been attachment to the distal end 2a of the barrel 2 as discussed above. The first track segment S_1 extends from a staging position (i) shown in Fig. 15A having a first catch 32 to a pre-injection position (ii) shown in Fig. 15B having a second catch 34 and has as a profile an initial portion (a) substantially parallel to the longitudinal axis A of the outer tube 12 followed by a final portion (b) angled with respect to the longitudinal axis A and serving as a cammed surface. When the collar 14 is attached to the distal end 2a of the barrel 2 and the pin 18 is in the staging position (i), the proximal end 12b of the outer tube 12 is in register with the distal end 2a of the barrel 2 allowing the barrel 2 to be inspected.

[0038] During the assembly process, the force element 16 is inserted in the outer tube 12.

The collar 14, attached to the distal end 2a of the barrel 2, is then inserted in the outer tube 12 such that the pin 18 (or plurality of pins, if there is a plurality of tracks) is in the first track segment S_1 (or plurality of first track segments). The outer tube 12 is moved in the proximal direction causing an initial compression of the force element 16 as the pin 18 travels to the beginning of the first track segment S_1 and becomes releasably retained in the first catch 32 thereby securing the outer tube 12 in the staging position (i).

[0039] As the outer tube 12 moves in the proximal direction causing the force member 16 to be compressed, the pin 18 travels the initial portion of the first track segment S_1 and is guided to the pre-injection position (ii) by the cammed surface which imparts an angular rotation to the collar releasably securing the pin 18 in second catch 34. When the collar 14 is attached to the distal end 2a of the barrel 2 and the pin 18 is in the second catch 34, the cannula 3 extends a first length L_1 beyond the distal end of the outer tube 12. The length L_1 of cannula extension depends on the particular size and configuration of the insertion device 1. At a minimum the length of extension allows visualization of the distal most tip of the cannula 3 at an insertion location prior to penetration of the skin.

[0040] A second track segment S_2 contiguous with the first track segment S_1 extends from the pre-injection position (ii) to a full-insertion position (iii) shown in Fig. 15C.. The second track segment S_2 is angled with respect to the longitudinal axis of the outer tube 12 and has an arcuate profile (c).

[0041] At the initiation of an injection, the distal end 12a of the outer tube 12 makes contact with the skin. The force applied by the skin to the outer tube 12 moves the pin 18 out of the first catch 32 and along beginning of the second track segment S_2 . As the skin is being penetrated by the cannula 3, continued application of force by the skin to the outer tube 12 further moves the outer tube 12 in the proximal direction and the pin 18 in the distal direction along the second

track segment S_2 to the fully inserted position (iii). When the collar 14 is attached to the distal end 2a of the barrel 2 and the pin 18 is in the full-insertion position (iii), the cannula 3 extends a second length L_2 greater than the first length L_1 from the distal end 12a of the outer tube 12.

The length L_2 of cannula extension at the full-insertion position (iii) depends on the particular size and configuration of the insertion device 1 and the subcutaneous location the medicament is to be delivered. The second track segment guides the pin 18 along a generally arcuate path imparting both axial translation and rotation to the collar 14. The outer tube 12 remains in the full-insertion position (iii) until withdrawal of the cannula 3 is initiated, typically after a full dose of the medicament is delivered.

5 [0042] A third track segment S_3 contiguous with the second track segment S_2 extends from the full-insertion position (iii) to a locked position (iv) shown in Fig. 15D having a third catch 36 in which the pin 18 is immovably retainable. The third track segment S_3 has an initial portion (d) extending from the full-insertion position (iii) substantially parallel to the longitudinal axis of the outer tube followed by an arcuate profile (e) providing a cammed surface terminating in an axially extending locked position (iv). As the cannula 3 is being
15 withdrawn after the desired dose of medicament has been delivered, the force applied by the skin to the outer tube 12 decreases and the outer tube 12 moves in the distal direction relative to the collar 14 under the reactive force of the force member 16 compressed between the collar and the outer tube. The third track segment S_3 initially guides the pin 18 substantially parallel to the
20 longitudinal axis and then along a generally arcuate path imparting both axial translation and a rotation to the collar and finally into the locked position (iv). When the collar 14 is attached to the distal end 2a of the barrel 2 and the pin 18 is immovably retained in the third catch 36, the outer tube 12 fully covers the cannula 3 in the entirety and is prevented from moving in either the proximal or distal directions.

25 [0043] Referring to the drawings in detail, where like numerals indicate like elements throughout, there is shown in Figs. 8-14 another preferred embodiment of a low radial profile needle safety device, generally designated 100, and hereinafter referred to as the "safety device" 100 in accordance with the present invention. The safety device 100 is also for use with the injection device 1 disclosed above.

30 [0044] The safety device 100 comprises an outer tube 112 configured to slidably receive therein a portion of the distal end 2a of the barrel 2. At least one track S' is formed in the inner surface of the outer tube 112. The at least one track S' has a plurality of contiguous segments

further discussed below. In some embodiments, the inner surface may have a plurality of tracks, each having the same configuration, positioned in a spaced-apart, aligned arrangement. A portion of the outer tube 112 has a generally U-shaped cut therethrough forming a flexible tongue 138 having a radially disposed ramp 140.

5 [0045] A collar 114 is slidably received in the outer tube 112. The collar 114 is attachable to the distal end 2a of the barrel 2. At least one pin 118 extends radially outwardly from a sidewall of the collar 114 and is slidably received in the at least one track S' formed in the inner surface of the outer tube 112. In embodiments in which the outer tube 112 may have a plurality of tracks S', the collar 114 may have a corresponding plurality of pins 118 projecting radially
10 outwardly from spaced-apart locations around the circumference of the sidewall. A force member 116 extending between the outer tube 112 and the collar 114 biases the outer tube 112 in a distal direction. In some embodiments, opposed ends of the force member 116 may be received and retained in a circumferential channel 124 in the outer surface of the collar 114 and a circumferential step 126 in the inner surface of the distal end 112a of the outer tube 112.

15 [0046] Referring to Fig. 14, in a preferred embodiment, the collar 114 is a body of revolution having a bore 122 therethrough and includes at least one and preferably four spaced-apart fingers 128 fixedly attachable to the distal end 2a of the barrel 2. Each finger 128 is sufficiently compliant to allow passage of the hub 5 through the bore 122 of the collar 114 and then to return to an initial configuration. Each finger 128 preferable is configured to conform to
20 the size and/or shape of a corresponding portion of the distal end 2a of the barrel 2. A gap or spacing 130 is preferably located between adjacent fingers 128, which allows for the collective expansion and contraction of the four fingers 128.

[0047] A channel formed in the distal end 128a of each finger 128 collectively forms a circular channel 124 in the outer surface of the collar 114 to receive one end of the force
25 element 116. A circumferential step 126 (*see*, Figs. 12 and 13) in the inner surface of the outer tube 112 is sized to receive and engage the distal end of the force member 116. Diametrically opposed pins 118 extends radially outwardly from the collar 114 and are sized to slidably engage the at least one track S' formed in the inner surface of the outer tube 112.

[0048] To mount the collar 114 to the barrel 2, the hub 5 may be inserted into and through
30 the proximal end 114b of the collar 114 and into and through the distal end 114a of the collar 114. As the hub 5 passes through the distal end 114a of the collar 114, each of the fingers 128 may flex radially outwardly from the longitudinal axis A until the hub 5 passes completely

therethrough. The fingers 128 then return to their initial state in which the distal end 128a of each finger 128 abuts the proximal surface 5b of the hub 5, thereby immovably attaching the collar 114 in place on the barrel 2 between the hub 5 and a shoulder or enlarged portion of the distal end 2a of the barrel 2. In some embodiments, the hub 5 may have a portion below the proximal surface 5b having ribs that extend into the gaps 130 between the fingers 128 further preventing rotation of the collar 114.

[0049] Referring to Figs. 12 and 13, in a preferred embodiment, the track S' has a plurality of segments, each segment corresponding to a relative position of the outer tube 112 with respect to the distal end 2a of the barrel 2 and/or to the cannula 3 projecting from the hub 5.

10 [0050] A first track segment S₁' is provided to allow the safety device 100 to be assembled and inspected after the collar 114 has been attachment to the distal end 2a of the barrel 2 as discussed above. The first track segment S₁' extends from a staging position (i) having a catch 132 to a pre-injection position (ii) having a catch 134 and has as a profile an initial portion a' substantially parallel to the longitudinal axis of the outer tube followed by a circumferential portion b' terminating in the catch 134 in register with the radially disposed ramp 140 on the flexible tongue 138 of the outer tube 112. When the collar 114 is attached to the distal end 2a of the barrel 2 and the pin 118 is in the staging position (i), the proximal end 112b of the outer tube 112 is in register with the distal end 2a of the barrel 2 allowing the barrel 2 to be inspected.

15 [0051] During the assembly process, the force member 116 is inserted in the outer tube 112. The collar 118, attached to the distal end 2a of the barrel 2, is then inserted in the outer tube 112 such that the pins 118 are in the catch 132 at the staging position (i). The outer tube 112 is moved in the proximal direction causing the force member 116 to be compressed as the pins 118 travel the length of the initial portion a' of the first track segment S₁'. The outer tube 112 is then rotated to move the pins 118 along the circumferential portion b' until the pins 118 become releasably retained in the catch 134 thereby securing the outer tube 112 in the pre-injection position (ii). When the collar 114 is attached to the distal end 2a of the barrel 2 and the pin 118 is in the second catch 134, the cannula 3 extends a first length L₁ beyond the distal end of the outer tube 112.

20 [0052] A second track segment S₂', contiguous with the first track section S₁', extends substantially parallel to the longitudinal axis A of the outer tube 112 from the pre-injection position (ii) to the full-insertion position (iii) of the outer tube. At the initiation of an injection, the distal end 112a of the outer tube 112 makes contact with the skin. The force applied by the

skin to the outer tube 112 causes the flexible tongue 138 to deflect radially outwardly as the pin 118 moves out of the catch 132, up the radially disposed ramp 140 and along the second track segment S_2' . As the skin is being penetrated by the cannula 3, continued application of force by the skin to the outer tube 112 further moves the outer tube 112 in the proximal direction and the pins 118 in the distal direction along the second track segment S_2' to the full-insertion position (iii). When the collar 114 is attached to the distal end 2a of the barrel 2 and the pin 118 is in the full-insertion position (iii), the cannula 3 extends a second length L_2 greater than the first length L_1 from the distal end 112a of the outer tube 112. The second track segment guides the pin 18 along a path substantially parallel to the longitudinal axis of the outer tube 112. The outer tube 112 remains in the full-insertion position (iii) until withdrawal of the cannula 3 is initiated, typically after a full dose of the medicament is delivered.

[0053] A third track segment S_3' , contiguous with the second track segment S_2' , has a profile having an initial portion c' extending from the fully inserted position (iii) substantially parallel to the longitudinal axis A of the outer tube 112 to a mid portion d' having a first extent d_1' angled with respect to the longitudinal axis A followed by a second extent d_2' parallel to the longitudinal axis A. The mid portion d' is followed by a final portion e' having an arcuate profile providing a cammed surface terminating in an axially extending locked position (iv).

[0054] After a full dose of the medicament has been delivered, and withdrawal of the cannula 3 is initiated, the force applied by the skin to the outer tube 112 decreases. Under the reactive force of the compressed force member 116, the outer tube 112 moves in the distal direction. The pins 118 move in the proximal direction along the third track segment S_3' which guides the pins 118 in the initial portion c' substantially parallel to the longitudinal axis A imparting to the outer tube 112 translation in the axial direction without rotation. The first extent d_1' of the mid portion d' cams the pins 118 in a direction angled with respect to the longitudinal axis A imparting to the outer tube 112 translation in the axial direction with rotation. The second extent d_2' of the mid portion d' guides the pins 118 substantially parallel to the longitudinal axis A imparting to the outer tube 112 translation in the axial direction without rotation. The final portion e' of the third track segment S_3' guides the pins 118 in a generally arcuate path imparting to the outer tube 112 both axial translation and a rotation until the pins 118 are in the locked position (iv) in the catch 136. In the locked position, the outer tube 112 is fully extended covering the cannula 3 in the entirety and is prevented from moving in the distal or proximal directions.

[0055] The foregoing detailed description of the invention has been disclosed with reference to specific embodiments. However, the disclosure is not intended to be exhaustive or to limit the invention to the precise forms disclosed. Those skilled in the art will appreciate that changes could be made to the embodiments described above without departing from the broad inventive concept thereof. Therefore, the disclosure is intended to cover modifications within the spirit and scope of the present invention as defined by the appended claims.

5

CLAIMS

We claim:

1. A needle safety device for an injection device having a generally cylindrical barrel with a distal end from which a cannula extends, the needle safety device comprising:

5 an outer tube within which the barrel is slideably receivable, the outer tube having a distal end and a proximal end;

a collar positioned within the outer tube, moveable relative thereto and attachable to the distal end of the barrel;

10 a force member positioned within the outer tube biasing the outer tube in a distal direction;

a track S formed in an inner surface of the outer tube; and

a pin extending radially outwardly from the collar slidingly engaging the track,

wherein the track comprises:

a first track segment extending from a staging position to a pre-injection position,

15 wherein the proximal end of the outer tube is in registry with the distal end of the barrel allowing the barrel to be inspected when the collar is attached to the distal end of the barrel and the pin is in the staging position, and

20 wherein the cannula extends a first length beyond the distal end of the outer tube when the collar is attached to the distal end of the barrel and the pin is in the pre-injection position;

a second track segment contiguous with the first track segment and extending from the pre-injection position to a full-insertion position,

25 wherein the cannula extends a second length greater than the first length from the distal end of the outer tube when the collar is attached to the distal end of the barrel and the pin is in the full-insertion position; and

a third track segment contiguous with the second track segment and extending from the full-insertion position to a locked position in which the pin is immovably retainable,

wherein the cannula is entirely within the outer tube when the collar is attached to the distal end of the barrel and the pin is immovably retained in the locked position.

2. The needle safety device according to claim 1, wherein the collar is a hollow cylinder terminating at a distal end with an annulus rotatably attachable to the distal end of the
5 barrel.
3. The needle safety device according to claim 1, wherein the outer tube has a first catch at the staging position and a second catch at the pre-injection position, the first and second catches able to releaseably retain the pin.
4. The needle safety device according to claim 1, wherein the first track segment
10 has an initial portion substantially parallel to the longitudinal axis of the outer tube followed by a final portion angled with respect to the longitudinal axis.
5. The needle safety device according to claim 1, wherein the second track segment is angled with respect to the longitudinal axis of the outer tube, has an arcuate profile and imparts both axial translation and rotation to the collar.
6. The needle safety device according to claim 1, wherein the third track segment
15 has an initial portion substantially parallel to the longitudinal axis of the outer tube followed by an arcuate portion providing a cammed surface terminating in an axially extending third catch at the locked position.
7. The needle safety device according to claim 1, wherein the collar is a hollow
20 cylinder terminating at a distal end with plurality of spaced-apart fingers fixedly attachable to the distal end of the barrel.
8. The needle safety device according to claim 1, wherein the outer tube has a cut therethrough forming a flexible tongue having a radially disposed ramp.
9. The needle safety device according to claim 1, wherein the outer tube has a first
25 catch at the staging position, a second catch at the pre-injection position, the first and second catches able to releaseably retain the pin, and a cut therethrough forming a flexible tongue having a radially disposed ramp in registry with the second catch and the first track segment has

an initial portion substantially parallel to the longitudinal axis of the outer tube followed by a circumferential portion terminating at the second catch.

10. The needle safety device according to claim 1, wherein the second track segment is substantially parallel to the longitudinal axis of the outer tube.

5 11. The needle safety device according to claim 1, wherein the third track segment has an initial portion substantially parallel to the longitudinal axis of the outer tube, followed by a mid-portion having a first extent angled with respect to the longitudinal axis and a second extent parallel to the longitudinal axis, followed by a final portion having an arcuate profile providing a cammed surface terminating in an axially extending third catch at the locked
10 position (iv).

12. The needle safety device according to claim 1, wherein the outer tube moves only in axial translation without rotation when the cannula extends beyond the outer tube.

13. The needle safety device according to claim 1, wherein the force member is positioned within the outer tube between the collar and the collar.

15

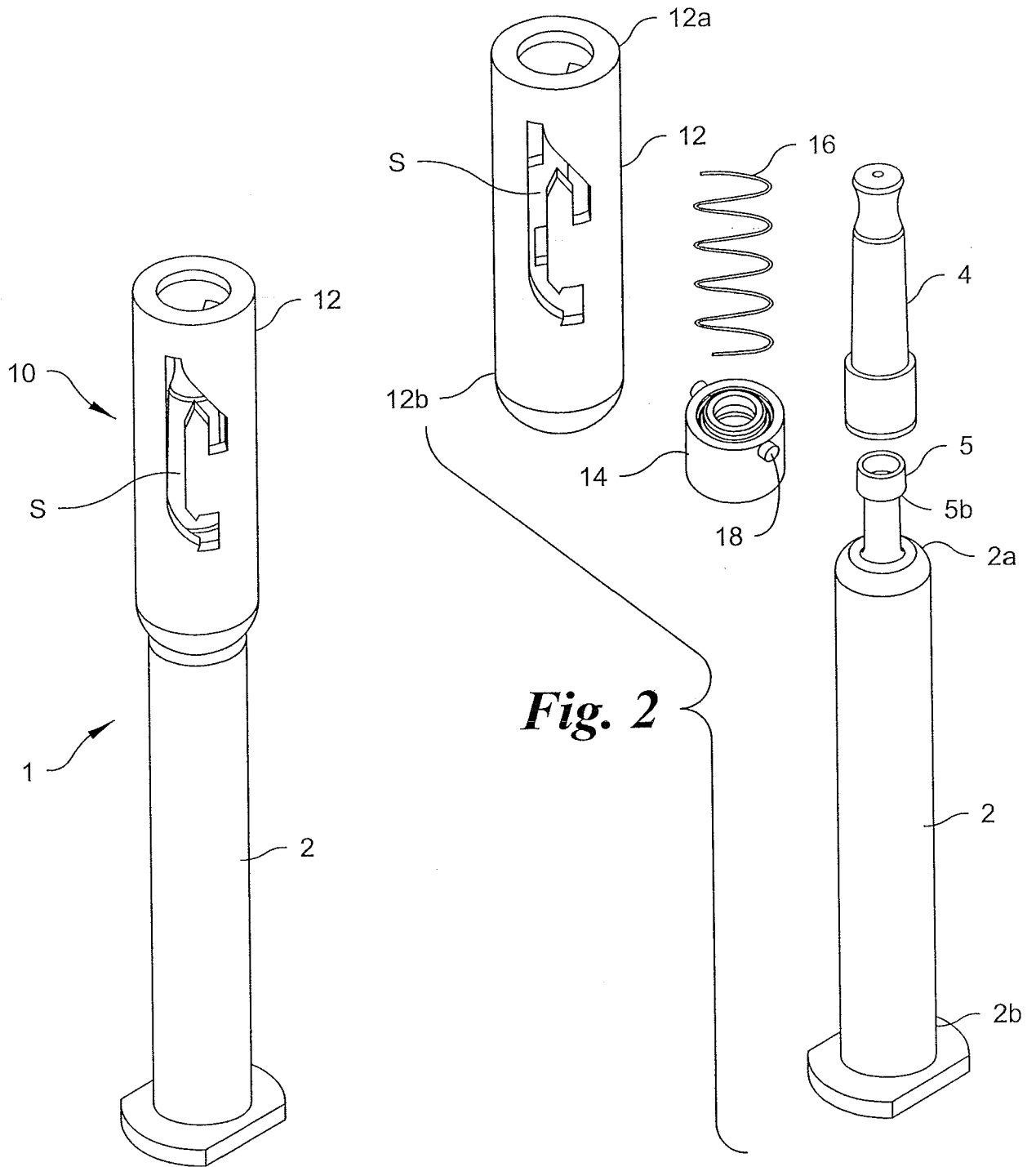

Fig. 1

Fig. 2

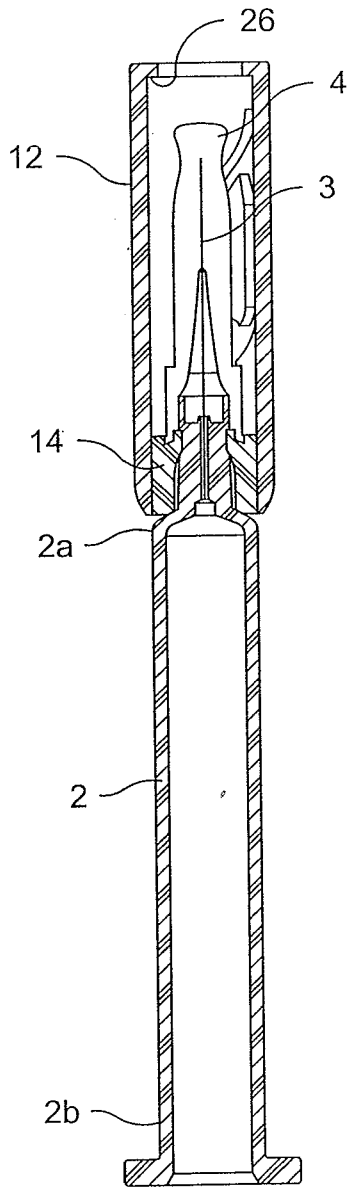

Fig. 3

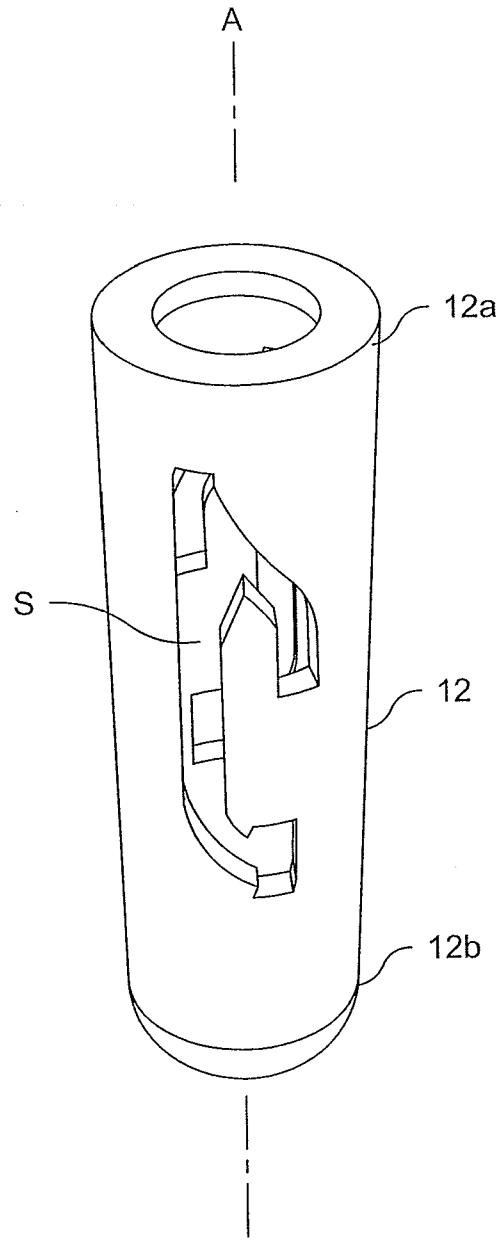

Fig. 4

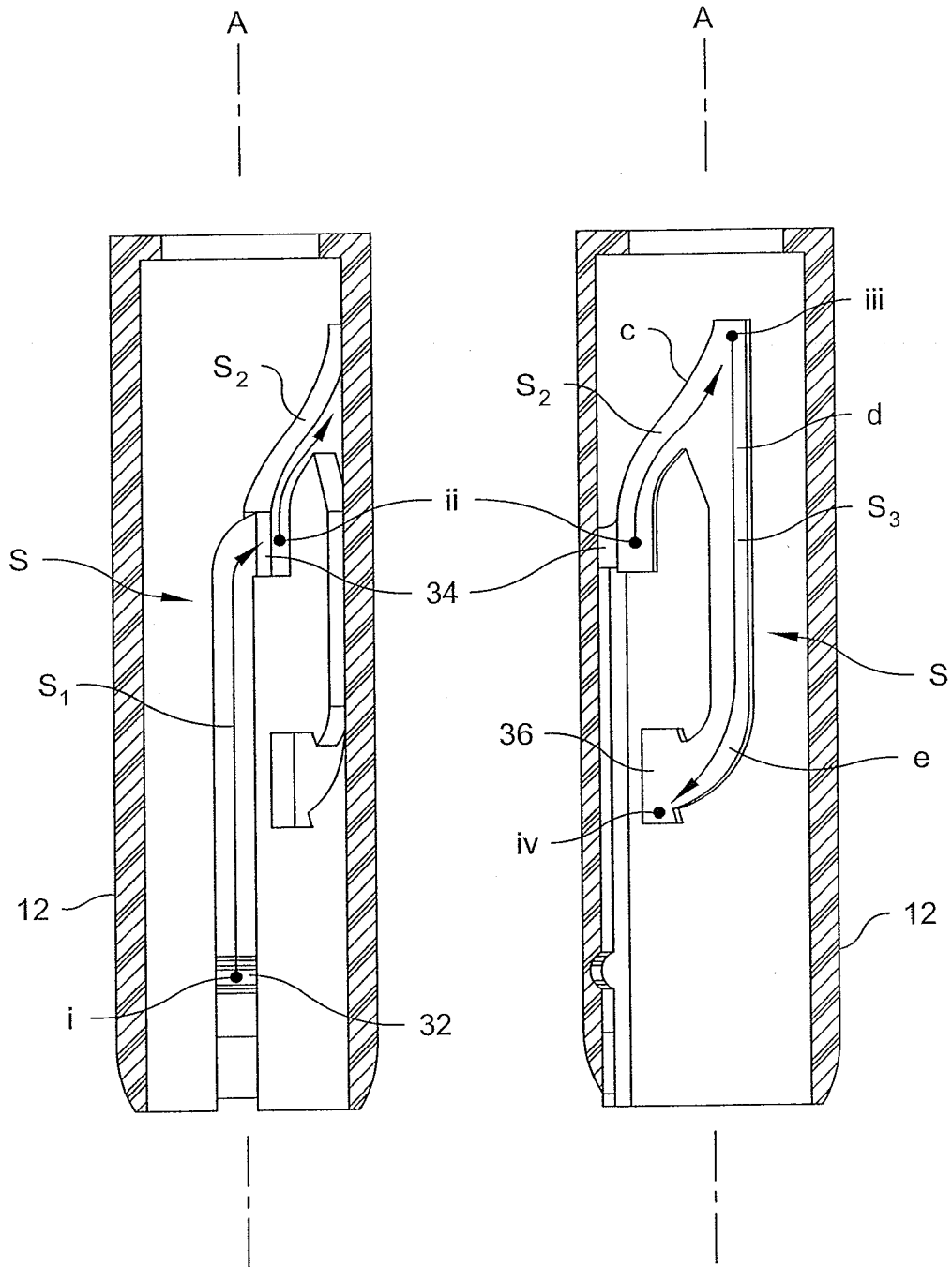

Fig. 5

Fig. 6

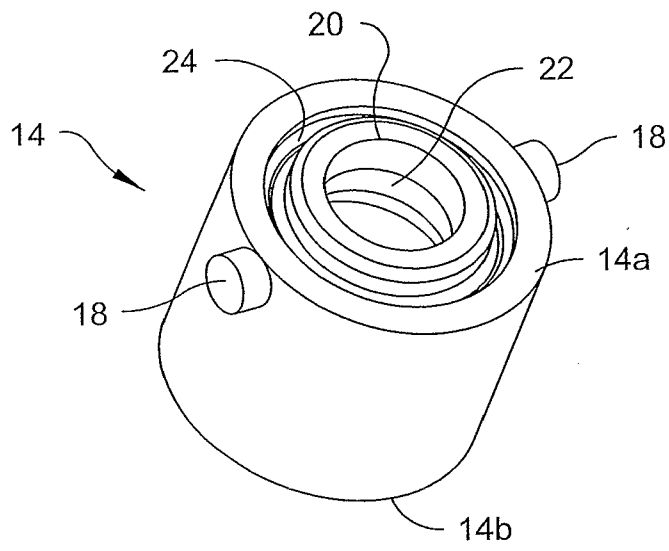

Fig. 7

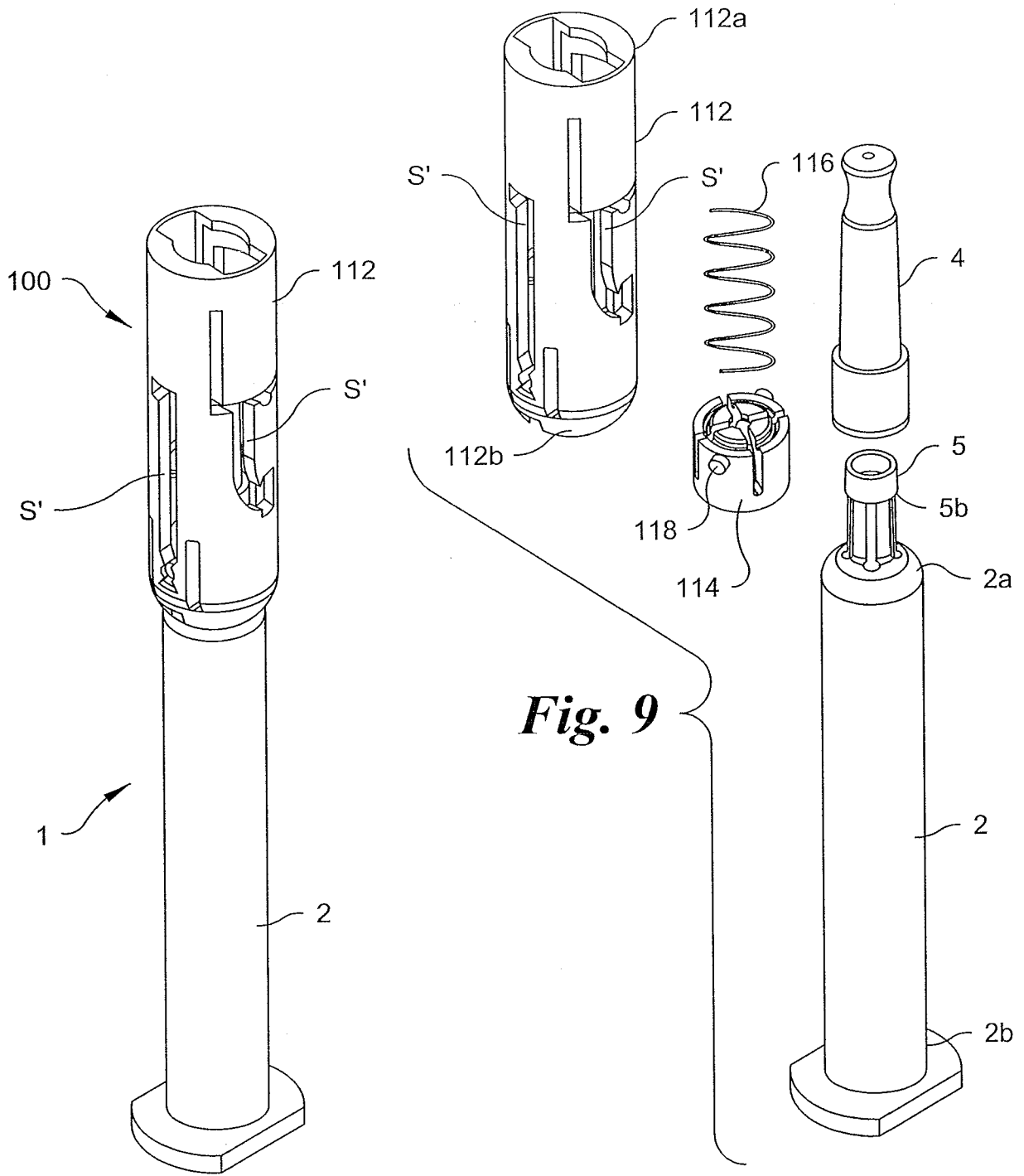

Fig. 8

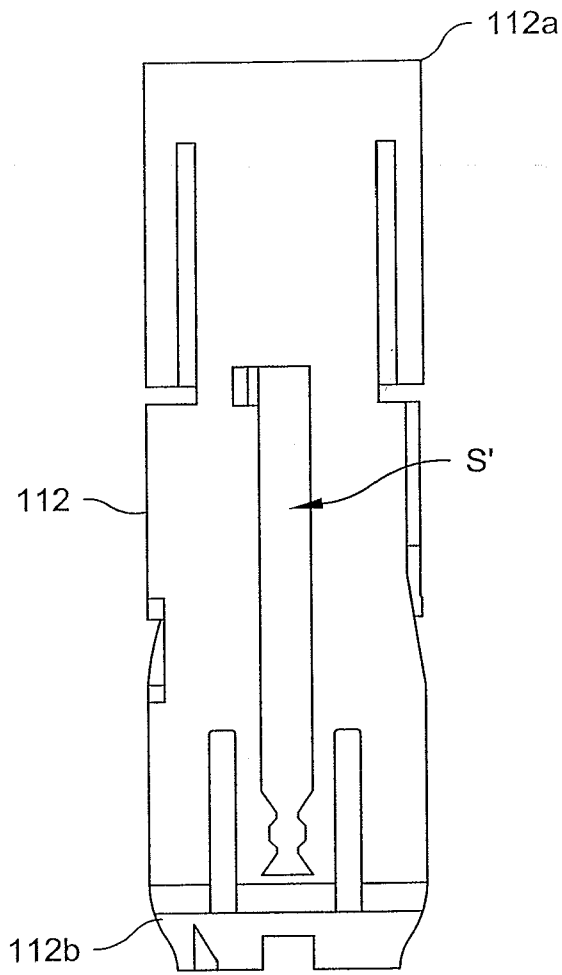

Fig. 10

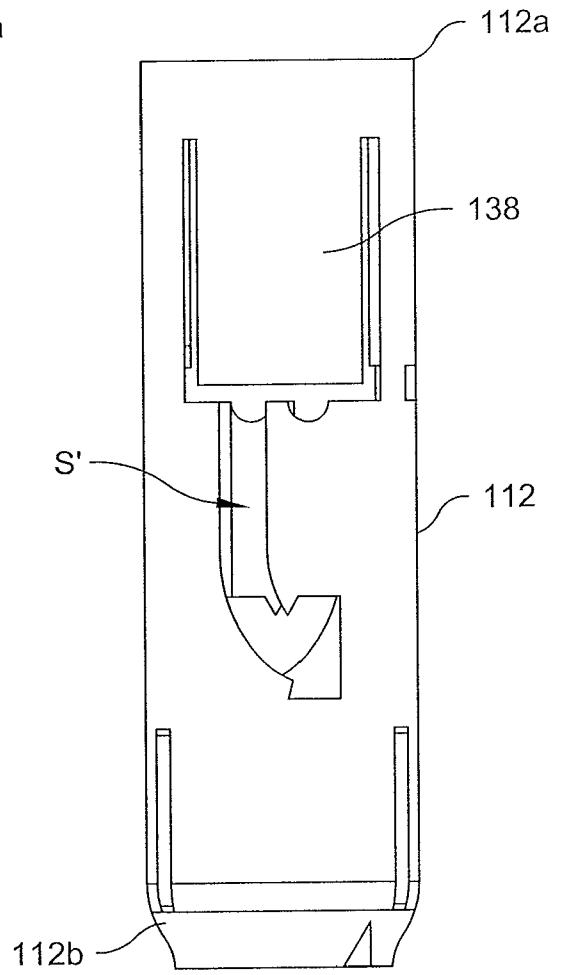

Fig. 11

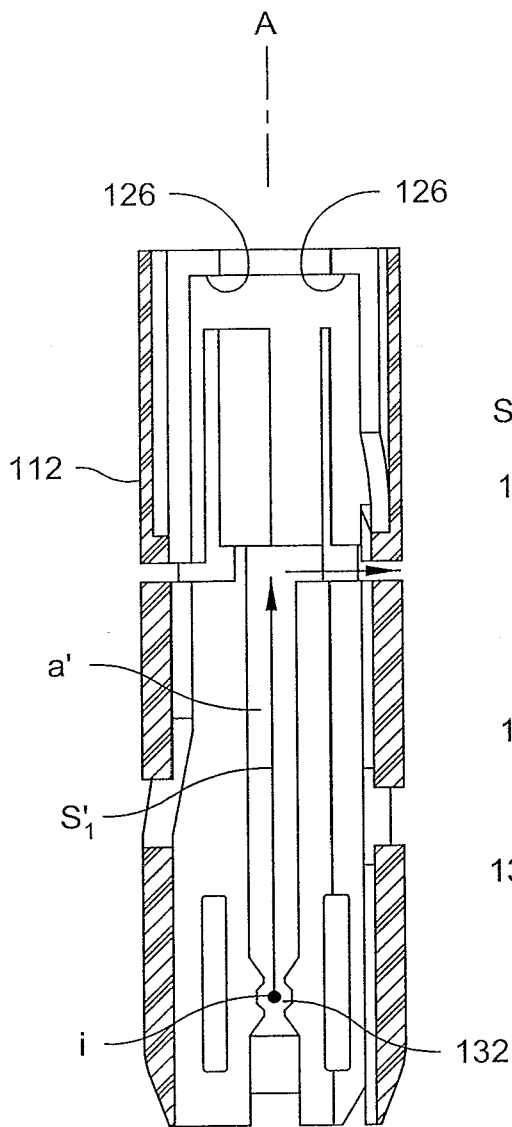

Fig. 12

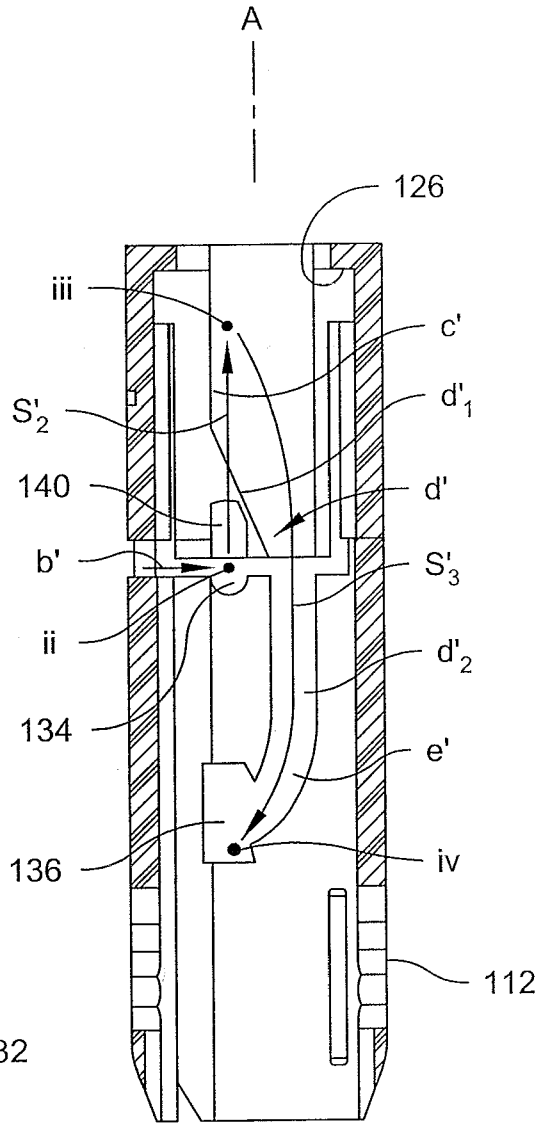

Fig. 13

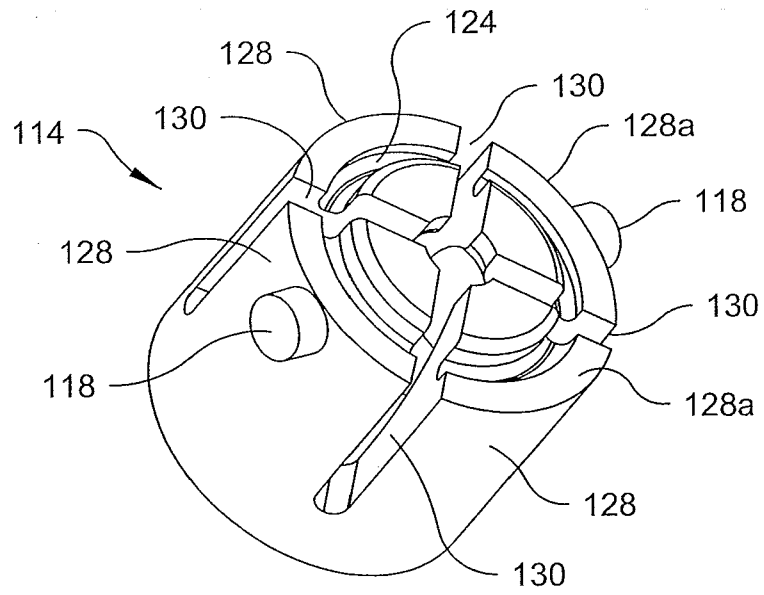

Fig. 14

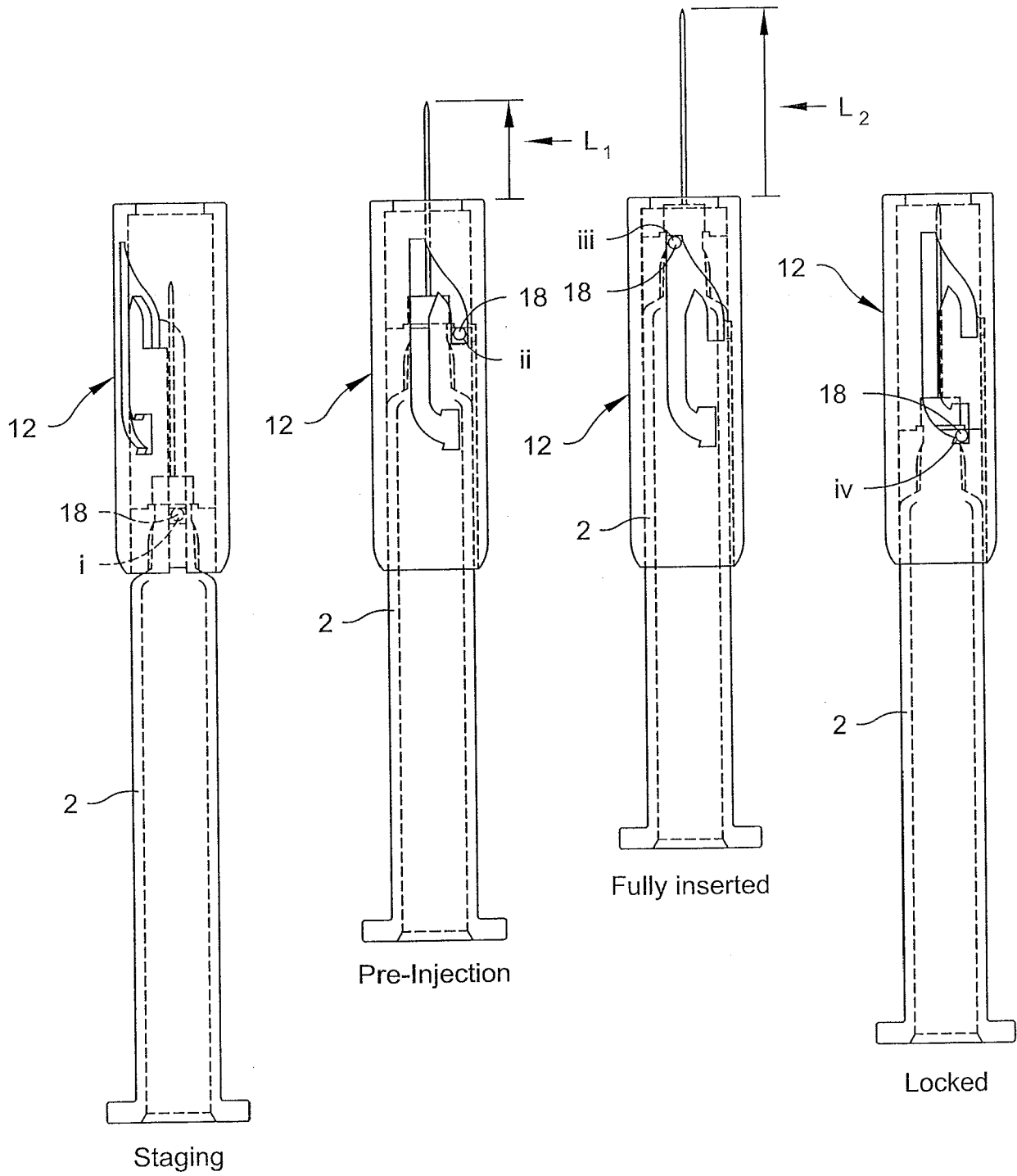

Fig. 15A Fig. 15B Fig. 15C Fig. 15D

INTERNATIONAL SEARCH REPORT

International application No PCT/US2013/029518
--

A. CLASSIFICATION OF SUBJECT MATTER INV. A61M5/32 ADD.		
According to International Patent Classification (IPC) or to both national classification and IPC		
B. FIELDS SEARCHED Minimum documentation searched (classification system followed by classification symbols) A61M		
Documentation searched other than minimum documentation to the extent that such documents are included in the fields searched		
Electronic data base consulted during the international search (name of data base and, where practicable, search terms used) EPO-Internal, WPI Data		
C. DOCUMENTS CONSIDERED TO BE RELEVANT		
Category*	Citation of document, with indication, where appropriate, of the relevant passages	Relevant to claim No.
X	US 4 966 592 A (BURNS CAMERON A [US] ET AL) 30 October 1990 (1990-10-30)	1,2,13
Y	figures 1-4 column 1, lines 8-12 -----	1,3-12
X	WO 2009/137845 A1 (GARBER JARROD [ZA]; MILLER ROY [ZA]) 12 November 2009 (2009-11-12) figures 1-3, 6 page 1, lines 31-32 page 5, lines 7-9 -----	1,2
Y	US 2006/189933 A1 (ALHEIDT TOM [US] ET AL) 24 August 2006 (2006-08-24) figures 14, 15 paragraphs [0002], [0006], [0072], [0074] -----	1,3-12
----- -/--		
<input checked="" type="checkbox"/> Further documents are listed in the continuation of Box C. <input checked="" type="checkbox"/> See patent family annex.		
* Special categories of cited documents :		
"A" document defining the general state of the art which is not considered to be of particular relevance	"T" later document published after the international filing date or priority date and not in conflict with the application but cited to understand the principle or theory underlying the invention	
"E" earlier application or patent but published on or after the international filing date	"X" document of particular relevance; the claimed invention cannot be considered novel or cannot be considered to involve an inventive step when the document is taken alone	
"L" document which may throw doubts on priority claim(s) or which is cited to establish the publication date of another citation or other special reason (as specified)	"Y" document of particular relevance; the claimed invention cannot be considered to involve an inventive step when the document is combined with one or more other such documents, such combination being obvious to a person skilled in the art	
"O" document referring to an oral disclosure, use, exhibition or other means	"&" document member of the same patent family	
"P" document published prior to the international filing date but later than the priority date claimed		
Date of the actual completion of the international search	Date of mailing of the international search report	
13 June 2013	24/06/2013	
Name and mailing address of the ISA/ European Patent Office, P.B. 5818 Patentlaan 2 NL - 2280 HV Rijswijk Tel. (+31-70) 340-2040, Fax: (+31-70) 340-3016	Authorized officer Herz, Markus	

INTERNATIONAL SEARCH REPORT

International application No
PCT/US2013/029518

C(Continuation). DOCUMENTS CONSIDERED TO BE RELEVANT

Category*	Citation of document, with indication, where appropriate, of the relevant passages	Relevant to claim No.
A	FR 2 884 723 A1 (BECTON DICKINSON FRANCE SOC PA [FR]) 27 October 2006 (2006-10-27) figures 1-4 -----	1-13

INTERNATIONAL SEARCH REPORT

Information on patent family members

International application No PCT/US2013/029518

Patent document cited in search report	Publication date	Patent family member(s)	Publication date	
US 4966592	A	30-10-1990	CN 1046853 A	14-11-1990
			MX 169538 B	09-07-1993
			US 4966592 A	30-10-1990
			WO 9014112 A1	29-11-1990

WO 2009137845	A1	12-11-2009	AU 2009244084 A1	12-11-2009
			CN 102036705 A	27-04-2011
			DE 112009001083 T5	24-03-2011
			GB 2471986 A	19-01-2011
			JP 2011519700 A	14-07-2011
			US 2011137261 A1	09-06-2011
			WO 2009137845 A1	12-11-2009

US 2006189933	A1	24-08-2006	EP 1858569 A1	28-11-2007
			JP 4738422 B2	03-08-2011
			JP 2008529717 A	07-08-2008
			US 2006189933 A1	24-08-2006
			WO 2006091201 A1	31-08-2006

FR 2884723	A1	27-10-2006	EP 1888151 A1	20-02-2008
			FR 2884723 A1	27-10-2006
			JP 4981030 B2	18-07-2012
			JP 2008536598 A	11-09-2008
			US 2009024093 A1	22-01-2009
			WO 2006131832 A1	14-12-2006
