

No. 702,146.

Patented June 10, 1902.

E. H. McCLOUD.
FOLDING DOOR.

(Application filed Apr. 22, 1901.)

(No Model.)

2 Sheets—Sheet 1.

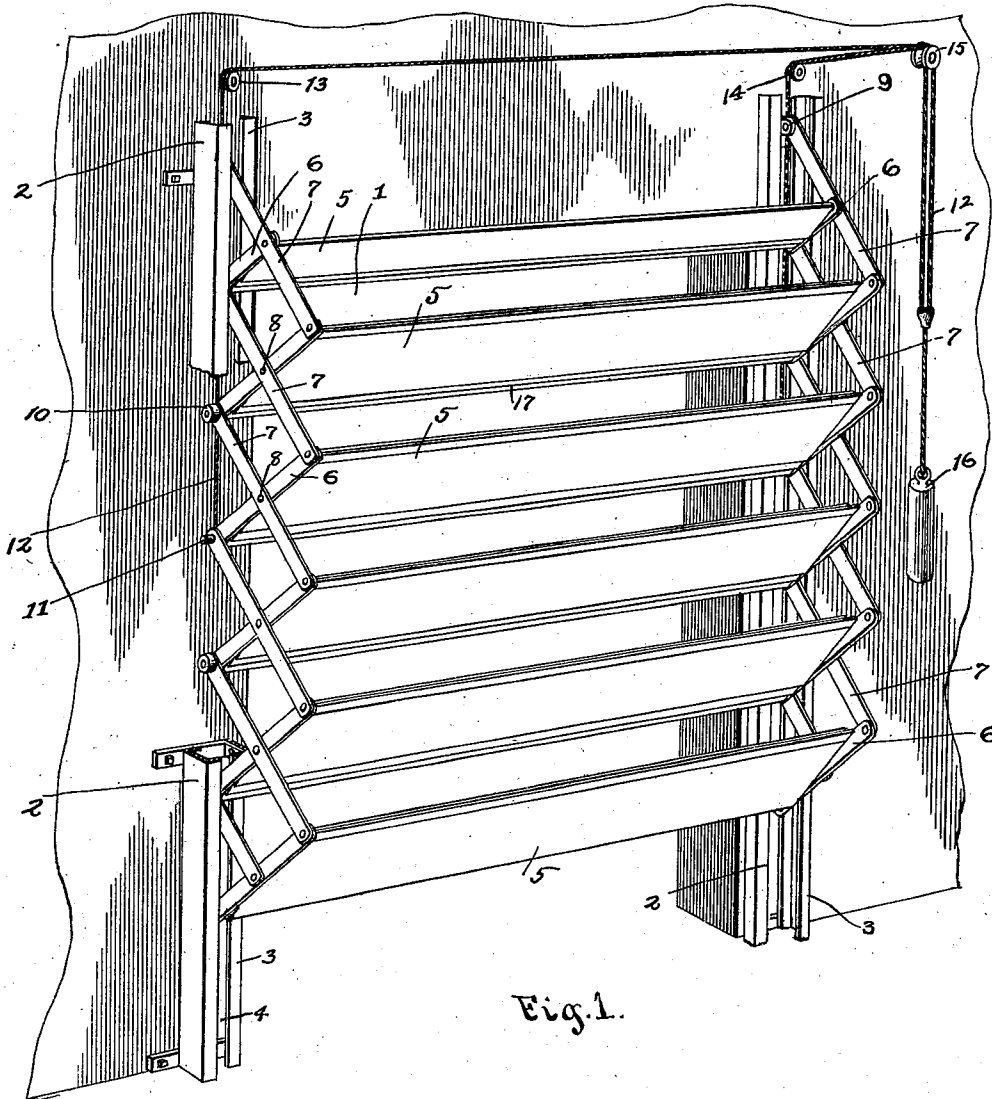

Fig. 1.

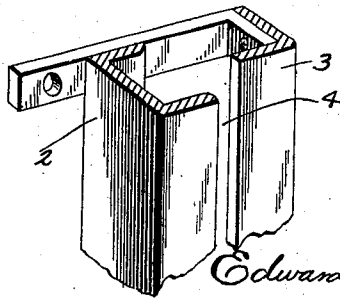

Fig. 2

WITNESSES:

H. B. Bradshaw
A. L. Phelps

INVENTOR

Edward H. McCloud

BY

C. Shepherd
ATTORNEY

E. H. McCLLOUD.
FOLDING DOOR.

(Application filed Apr. 22, 1901.)

(No Model.)

2 Sheets—Sheet 2.

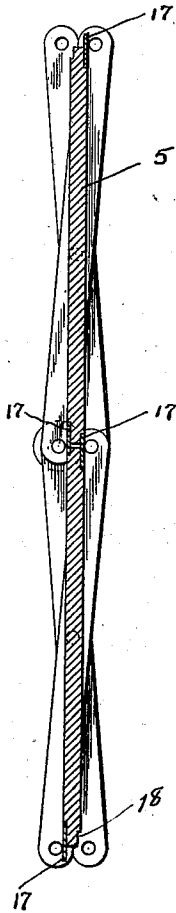

Fig. 3.

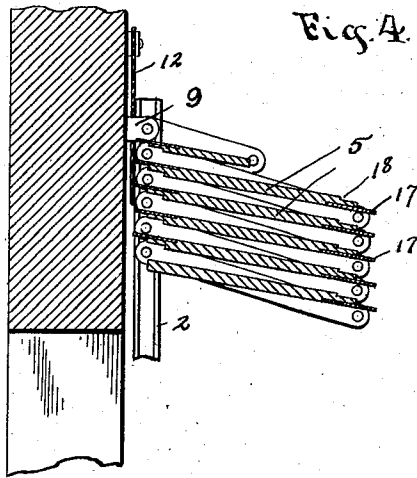

Fig. 4.

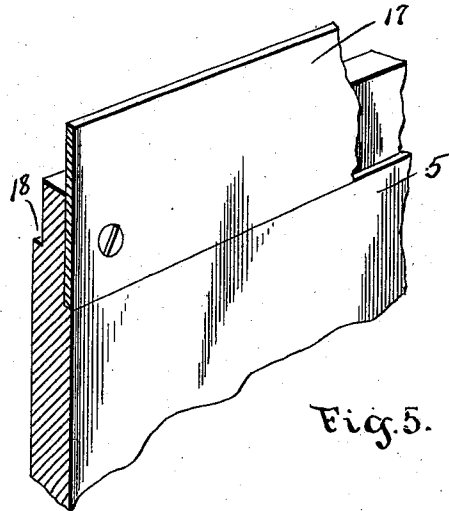

Fig. 5.

WITNESSES:

H. B. Bradshaw
A. L. Phelps

INVENTOR

Edward H. McCloud

BY

C. Shepherd
ATTORNEY

UNITED STATES PATENT OFFICE.

EDWARD H. McCLOUD, OF COLUMBUS, OHIO.

FOLDING DOOR.

SPECIFICATION forming part of Letters Patent No. 702,146, dated June 10, 1902.

Application filed April 22, 1901. Serial No. 56,879. (No model.)

To all whom it may concern:

Be it known that I, EDWARD H. McCLOUD, a citizen of the United States, residing at Columbus, in the county of Franklin and State of Ohio, have invented a certain new and useful Improvement in Folding Doors, of which the following is a specification.

My invention relates to the improvement of folding doors of that class which are formed of jointedly-connected sections adapted to be folded into compact form above or at one side of a doorway.

The objects of my invention are to provide a superior construction of folding door wherein improved means are employed for providing a jointed or folding connection of the sections which will insure a uniform folding movement of the sections and the various bars forming the folding-truss connection between said sections, to so construct my improved folding-door mechanism as to admit of its being easily and readily operated, and to produce other improvements in details of construction and arrangement of parts, which will be more fully pointed out hereinafter. These objects I accomplish in the manner illustrated in the accompanying drawings, in which—

Figure 1 is a perspective view of a doorway, showing my improved folding door in a partially-folded position therein. Fig. 2 is a detail view in perspective of a portion of one of the guides. Fig. 3 is a central vertical section through two of the folding-door sections, showing the same in their closed or vertical positions. Fig. 4 is a sectional view through the upper portion of the door-frame and my improved door, showing the latter folded above said doorway; and Fig. 5 is a detail view in perspective of a portion of one of the door-sections.

Similar numerals refer to similar parts throughout the several views.

In carrying out my invention I provide on opposite sides of a door 1 vertically-arranged guides comprising suitably-connected angular plates 2 and 3, arranged so that a vertically-slotted opening 4 is formed between the forward sides or intumed flanges of said sections 2 and 3.

5 represents the parallel transverse sections of my improved door, each section having

each of its ends rigidly connected with an end cleat or bar 6, the ends of said sections 5 extending, as indicated in the drawings, in substantially diagonal directions across the faces of said end bars 6. The sections 5 are jointedly connected through the medium of truss-bars 7, one of these truss-bars having its central portion pivotally connected, as indicated at 8, to the center of the length of one of the end bars 6, while the ends of said bar 7 are respectively pivoted to the upper or outer end of the bar 6 of the next lower section 5 and the lower or inner end of the end bar 6 of the next higher section 5. The upper truss-bar 7 of the series has its upper or inner end pivotally connected, as indicated at 9, at a point between the upper end portions of the guide-channel or angle-pieces 2 and 3.

The above description applies to the jointed construction at both ends of the door-sections.

As indicated at 10, a desirable number of the pivot-pins 11, which connect the inner or lower ends of the door-sections and the upper or inner ends of the truss-bars 7, may have journaled or otherwise mounted thereon friction-rollers, which are adapted to run and bear within the channel-section 2 of the guides.

Connected with the folding truss, which is formed by the pivotal connection above described of the section end bars 6 and truss-bars 7 on each side of the door-body at any suitable point, are the lower ends of operating-cords 12, these cords running upward within the guides 2 3 and over pulleys 13 and 14, respectively, thence over a conveniently-located pulley 15, below which said cords are united and are made to support a counterbalancing-weight 16.

In constructing the sections 5 I provide one of its longer sides thereof adjacent to its edge portion with a projecting lip or plate 17, this plate being shown more clearly in Fig. 5 of the drawings, and on the opposite face and from the opposite longer edge portion of the section I employ a similar projecting plate 17. Opposite each of the plates 17 and on the reverse sides of the section 5 I cut away the face of said section adjacent to its edge portions, forming offsets or recesses 18 therein.

In utilizing my invention where the same is adapted to be folded when not in use in compact form above a door, such as shown in

Fig. 1 of the drawings, it is obvious that when the herein-described door is lowered over the door-opening the closing together of the bars forming the folding truss will result in the sections 5 being brought into such vertical alinement as to result in the projecting portions of the edge plates 17 of one door-section engaging or fitting into the recessed portions 18 of the adjoining sections, said sections thus being so joined as to provide a closed and substantially vertical door-surface. Owing to the means which I have described, whereby the sections are jointedly connected and which embodies the employment of three pivot-pins for each of the sections, it is obvious that a uniform motion will be imparted to the sections and to the connecting trusses which will insure a corresponding folding movement of all the connected parts and permit of the sectional door being folded into compact form in such position with relation to the doorway as to present no obstruction to the latter.

It will be observed that the means which I employ in carrying out my invention are such as to insure a simple and positive operation.

Having now fully described my invention, what I claim, and desire to secure by Letters Patent, is—

1. In a folding door, the combination with a plurality of door-sections 5, of a folding-truss connection between the ends of said sections, the bars forming said folding truss being pivotally connected with each end of each of said sections at three points and a pivotal connection of one end of each of said folding trusses

with a supporting structure, substantially as specified.

2. In a folding door, the combination with the door-sections 5, of a folding or jointed truss connection for the ends of said section comprising bars 7 each pivotally connecting a set of three of said door-sections and means for hinging or pivotally connecting said folding door with a supporting structure, substantially as specified.

3. In a folding door, the combination with a door-frame and guideways on opposite sides thereof, of a folding sectional door comprising sections 5 and truss-bars jointedly connecting the ends of said sections as described, the inner pivots of one or more of said truss-bars carrying friction-rollers adapted to run in said guides, a hinged or pivotal connection of said door with a supporting structure and means for counterbalancing the weight of said door, substantially as specified.

4. In a folding door, the combination with a plurality of sections 5, each of said sections having its edge portions and opposite sides provided with projecting longitudinally-arranged plates 17 and recesses 18 formed in said sections on opposite sides from said plates, of a folding-truss connection for the ends of said sections, each of the truss-bars connecting three of said section ends, substantially as specified.

EDWARD H. McCLOUD.

In presence of—

A. L. PHELPS,
W. L. MORROW.