

A. L. KRODINGER,
METAL CORNER BEAD AND STOPPING-OFF STRIP,
APPLICATION FILED SEPT. 30, 1918.

1,298,357.

Patented Mar. 25, 1919.

Fig. 1

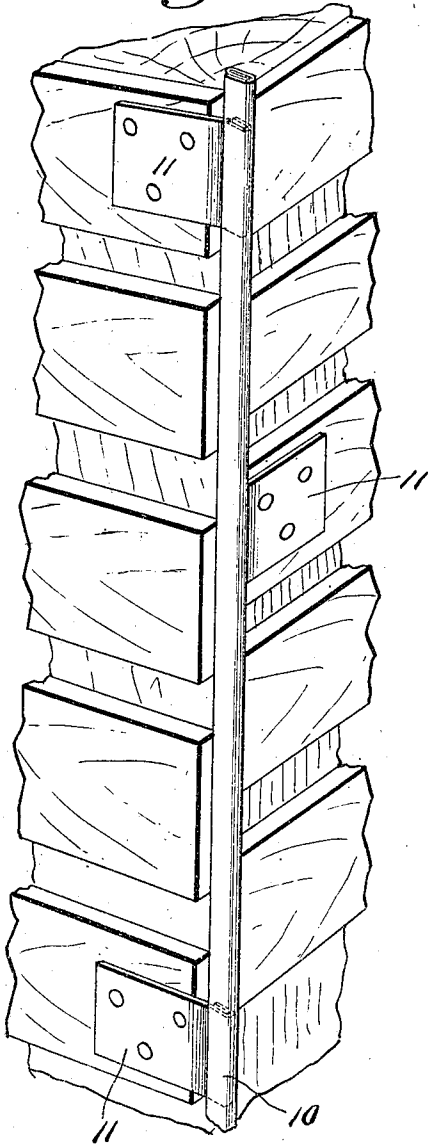

Fig. 2

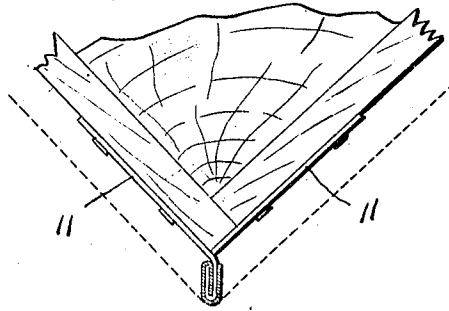

Fig. 3

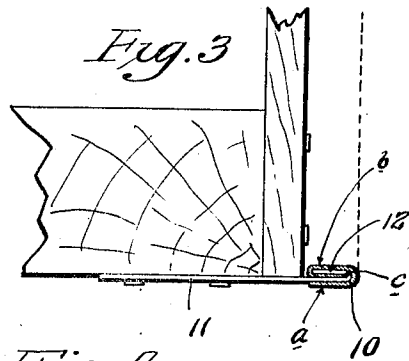
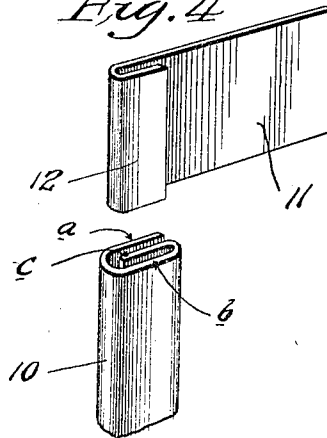

Fig. 4



Inventor
A. L. Krodinger
By *J. H. Cornwell*, Atty

UNITED STATES PATENT OFFICE.

ALOIS L. KRODINGER, OF MAPLEWOOD, MISSOURI.

METAL CORNER-BEAD AND STOPPING-OFF STRIP.

1,298,357.

Specification of Letters Patent.

Patented Mar. 25, 1919.

Application filed September 30, 1918. Serial No. 256,177.

To all whom it may concern:

Be it known that I, ALOIS L. KRODINGER, a citizen of the United States, residing at Maplewood, St. Louis county, Missouri, have invented a certain new and useful Improvement in Metal Corner-Beads and Stopping-Off Strips, of which the following is a full, clear, and exact description, such as will enable others skilled in the art to which it appertains to make and use the same, reference being had to the accompanying drawings, forming part of this specification.

My invention relates to a combined corner bead and stopping-off strip, particularly designed for use upon the external or outwardly presented corners of building walls for the purpose of supporting and protecting the plaster at the exposed corners, and likewise enabling a plastered corner to be produced which has a neat and finished appearance.

The principal objects of my invention are, to provide a corner bead and stopping-off strip which can be easily and cheaply produced owing to the relatively small amount of material entering into its construction; to provide a device which can be advantageously employed either as a corner bead or a stopping-off strip which latter, it will be understood, is generally utilized upon a horizontally disposed corner between vertically and horizontally disposed plastered surfaces; and, further, to produce with a minimum amount of material a combined corner bead and stopping-off strip which is exceptionally strong and rigid, thereby affording a substantial support for the adjacent plaster in which it is embedded.

With the foregoing and other objects in view, my invention consists in certain novel features of construction and arrangement of parts, hereinafter more fully described and claimed, and illustrated in the accompanying drawings, in which—

Figure 1 is a perspective view of a corner bead of my improved construction, the same being applied for use upon an exposed or outwardly presented corner of a building structure.

Fig. 2 is a horizontal section taken through the corner of a building structure and showing my improved corner bead applied therein.

Fig. 3 is a vertical section of a portion of a building structure and showing my improved device applied thereto and performing the functions of a stopping-off strip.

Fig. 4 is a perspective view of one of the attaching plates forming a part of the strip and a portion of the body of the strip to which said plate is attached.

Referring by numerals to the accompanying drawings which illustrate a practical embodiment of my invention, 10 designates the body of the corner bead, the same being constructed from a single piece of sheet metal bent along parallel lines by a suitable metal bending machine, such as a break, to form three parallel legs or lays *a*, *b*, and *c*, the legs or layers *a* and *c* being the terminal or side portions of said piece of sheet metal, and the legs or layer *c* being disposed between legs or layers *a* and *b*. (See Fig. 4).

Secured to the body of the bead thus formed are attaching plates or wings 11, the same being constructed of sheet metal and preferably rectangular in shape, one end portion of which is rebent to form a hook 12, the same occupying the spaces between the legs or layers *a*, *b*, and *c* of the bead.

When pressure is applied to the body of the bead by the forming machine or break, the engaged ends of the attaching plates or wings 11 are firmly clamped between the layers of the bead and thus the two parts are rigidly connected so that the completed device is in effect a one-piece structure.

It will be understood that the beads are formed in sections of considerable length and that when used or applied to the corners between walls, they can be readily cut according to requirements.

When applied for use, the attaching plates or wings 11 are alternately bent away from each other so as to occupy planes in angles corresponding to the angularity of the faces of the walls adjacent to the corner to which the bead is applied and said plates are secured to the lath or wall structure in any suitable manner, preferably by means of small nails.

When the plaster is applied to the outer faces of the wall structures, the body of the bead occupies a vertical position at the corner between the faces of the walls, as illustrated in Fig. 2, thereby forming an effective support for the adjacent plaster and producing a neat and finished appearance at the corner.

When my improved device is utilized as a stopping-off strip along the lower edge of a vertically disposed layer of plaster, as

illustrated in Fig. 3, the attaching plates 11 are all bent into the same plane and applied to the underside of the wall structure with only the body of the bead 10 projecting beyond the face of the wall structure. When so positioned, the bead serves as a support and finishing strip for the lower edge of the plaster applied to the vertical face of the wall.

10 In the manufacture of my improved corner bead, I prefer to utilize galvanized sheet metal in order to prevent the formation of rust.

15 A combined corner bead and stopping-off strip of my improved construction can be readily applied for use, can be very cheaply manufactured owing to the relatively small amount of material entering into its construction and said device is very effective in performing its intended functions.

20 It will be readily understood that minor

changes in the size, form and construction of the various parts of my improved corner bead and stopping-off strip may be made and substituted for those herein shown and described, without departing from the spirit of my invention, the scope of which is set forth in the appended claim.

I claim:

30 A combined metal corner bead and stopping-off strip comprising a body formed of a single piece of sheet metal bent to form three substantially parallel legs of equal length and width, and with one leg positioned between the other two, and a plurality of attaching plates secured to said body by having portions of their ends clamped between the legs forming the body of the bead.

40 In testimony whereof I hereunto affix my signature this 27th day of September, 1918

ALOIS L. KRODINGER.

Copies of this patent may be obtained for five cents each, by addressing the "Commissioner of Patents, Washington, D. C."